

A review of hybrid wave-tidal energy conversion technology

Chen, Peihao; Wu, Dawei

DOI:

[10.1016/j.oceaneng.2024.117684](https://doi.org/10.1016/j.oceaneng.2024.117684)

License:

Creative Commons: Attribution (CC BY)

Document Version

Publisher's PDF, also known as Version of record

Citation for published version (Harvard):

Chen, P & Wu, D 2024, 'A review of hybrid wave-tidal energy conversion technology', *Ocean Engineering*, vol. 303, 117684. <https://doi.org/10.1016/j.oceaneng.2024.117684>

[Link to publication on Research at Birmingham portal](#)

General rights

Unless a licence is specified above, all rights (including copyright and moral rights) in this document are retained by the authors and/or the copyright holders. The express permission of the copyright holder must be obtained for any use of this material other than for purposes permitted by law.

- Users may freely distribute the URL that is used to identify this publication.
- Users may download and/or print one copy of the publication from the University of Birmingham research portal for the purpose of private study or non-commercial research.
- User may use extracts from the document in line with the concept of 'fair dealing' under the Copyright, Designs and Patents Act 1988 (?)
- Users may not further distribute the material nor use it for the purposes of commercial gain.

Where a licence is displayed above, please note the terms and conditions of the licence govern your use of this document.

When citing, please reference the published version.

Take down policy

While the University of Birmingham exercises care and attention in making items available there are rare occasions when an item has been uploaded in error or has been deemed to be commercially or otherwise sensitive.

If you believe that this is the case for this document, please contact UBIRA@lists.bham.ac.uk providing details and we will remove access to the work immediately and investigate.



A review of hybrid wave-tidal energy conversion technology

Peihao Chen, Dawei Wu*

Department of Mechanical Engineering, University of Birmingham, B15 2TT, United Kingdom

ARTICLE INFO

Keywords:

Wave energy
Tidal energy
Hybrid energy
Energy converter
Non-linear modeling

ABSTRACT

Ocean renewable energy, such as wave and tidal energies, is important for energy supply and decarbonization of offshore platforms and ships. However, the intermittent and non-dispatchable nature of wave and tidal energy remains a significant challenge. The hybrid wave-tidal energy conversion presents a potential solution to enhance output power and stability by leveraging their complementary characteristics. This paper reviews the current state of hybrid wave-tidal energy conversion technology, focusing on device design, modeling methods and testing methods. Many current hybrid wave-tidal energy converters (HWTEC) have not considered effective coupling among the modules of sub-systems to maximize efficiency. Modeling and simulation methods are mainly based on studies of single wave or tidal energy conversion, and non-linear system modeling is rare. The assumption of continuous functions in most models can lead to discrepancies from real-life conditions. Advancement of modeling approaches, co-simulation algorithms, and dedicated dry lab and pool tests for HWTEC are desired. While HWTEC is potential for improving ocean energy conversion, addressing key challenges of device design, modeling, testing and economic evaluation are essential for realizing its full potential in contributing to decarbonization.

1. Introduction

Energy is the driving force of development. Under the pressure of global warming and energy crisis, clean and renewable energy is an important research field. The ocean covers 71% of the earth surface. As the most widely distributed energy in the ocean, wave energy and tidal energy have always been research hotspots, as known as blue energy. However, compared with wind energy and solar energy, which come from nature as well but are more mature, wave energy and tidal energy have not yet been applied widely in industry.

In research on single wave or tidal energy conversion technology, the output power, efficiency and stability are the most concerned performances and have been always the challenge in this field. At present, hybrid wave-tidal energy converter (HWTEC) has attracted some attention, due to its advantage over previous single wave or tidal energy converter in the performances mentioned above. This paper reviews the state of hybrid wave-tidal energy conversion technology. Meanwhile, some designs and analysis methods for single wave or tidal energy conversion technology, which are potential to be utilized in futural hybrid wave-tidal energy conversion technology, are summarized as well. And the current research gaps and the challenges are clarified in every section.

The rest of the paper is organized as follows. The features and differences, advantage and disadvantage of wave and tidal energy are introduced in the rest of Section 1. The state of hybrid wave-tidal energy conversion is reviewed in detail from device design, analysis methods and test methods in Section 2. The research gaps and potential research directions are proposed after a brief summary in Section 3 to conclude this paper.

1.1. Features and differences

Both wave energy and tidal energy are hydrokinetic types of energy, but they are different in their generation and dynamic characteristics. Wave energy is the mechanical energy produced by the ups and downs of sea surface water under the action of wind, and tidal energy is the mechanical energy produced by the periodic flow of seawater in depth under the influence of the gravitational force from sun and moon (Roy et al., 2018).

In most weather conditions, ocean wave in the deep ocean with the wave steepness less than 1/10 (theoretical value is 1/7) can be considered as two-dimensional small-amplitude gravity wave (also referred to as linear wave). In the space coordinate system, the wave surface equation can be expressed as:

* Corresponding author.

E-mail address: d.wu.1@bham.ac.uk (D. Wu).

$$\begin{cases} \zeta = a \sin(kx - \sigma t) \\ k = \frac{2\pi}{\lambda} \\ \sigma = \frac{2\pi}{T} \\ H = 2a \end{cases} \quad (1)$$

where ζ is the displacement of the water surface at coordinate x relative to the average still water surface at time t , a is the amplitude of wave, $(kx - \sigma t)$ is phase angle, k is the wavenumber, σ is the circular frequency, λ is the wavelength, T is the period, and H is the wave height. When the wave steepness exceeds $1/10$ (theoretical value is $1/7$), the wave surface will be broken. At this time, the ocean wave is a non-linear wave, and Airy wave theory (also referred to as Airy wave theory) is no longer applicable. Due to the huge and complex non-linear wave theory system, it will not be expanded here.

For small-amplitude wave, the motion track equation of the water particle whose equilibrium position is (x_0, z_0) is

$$(x - x_0)^2 + (z - z_0)^2 = a^2 \exp(k|z_0|) \quad (2)$$

The track is an ellipse, with the major axis parallel to the x -axis and the minor axis parallel to the z -axis. And as the depth increases, the motion radius of water particles decays exponentially. It is generally considered that the waveform can be negligible when the water depth is greater than $1/2$ of the wavelength ($|z_0| \geq \lambda/2$). Therefore, wave energy is mainly distributed near the water surface. The potential energy of a wave per unit width in the direction of the wave crest line and within a wavelength range is

$$E_p = \int_0^{\zeta} \int_0^{\lambda} \rho g z dx dz = \frac{\rho g H^2 \lambda}{16} \quad (3)$$

From Eq. (3), the waveform in deep water can be negligible, so the movement of tidal current is mainly horizontal. And the kinetic energy flux in tidal current can be expressed as:

$$E_p = \frac{\rho}{2} \int_A U^3 dA \quad (4)$$

where U is the flow velocity, and A is the effective cross-sectional area (i. e., the area of the orthographic projection of the fluid passing surface in the flow velocity direction).

Therefore, the output power of wave energy is proportional to the square of the wave height, and the output power of tidal energy is proportional to the cube of the flow velocity of tide current. In order to make full use of the energy from wave and tide, designing suitable and efficient equipment based the physical characteristics of wave and tide is the key point in wave and tidal energy conversion.

1.2. Advantage and disadvantage of blue energy

1.2.1. Advantage

The most notable feature of blue energy is the extremely high reserves. The reserves of wave energy and tidal energy in the global ocean are 800 TWh/y and 8000–80000 TWh/y respectively (Khan et al., 2017). Compared with solar and wind energy, which are only available for 20%–30% of the time, wave energy is available for about 90% of the time. And the power density of the wave farm is 2–3 kW/m², much higher than 0.1–0.2 kW/m² of the solar farm and 0.4–0.6 kW/m² of the wind farm (Khan et al., 2017; Ramli et al., 2022). Since the density of water is about 830 times that of air, the power density of tidal current is 2–3 orders of magnitude greater than that of wind energy. The tidal energy within a range of about 4–12 m along the coast is estimated to 1–10 MW/km. And compared with wind and solar energy, tidal energy has regularity and predictability in a certain time scale, so it is more suitable as a stable energy supplement (Kaufmann et al., 2019; Khan

et al., 2017; Shetty and Priyam, 2022).

The predictability of renewable energy is important. Wave energy and tidal energy are considered as a predictable high-quality energy. The variability of wave energy is low on short timescales (in hours or days), but large on long timescales (in seasons or years). While tidal current changes a lot on short timescales, but has high regularity over longtime scales (Lewis et al., 2015, 2019; Neill et al., 2014; Reikard, 2013). Therefore, the prediction of wave and tidal energy is more accurate than that of wind and solar energy, which is more helpful for regulating the power supply.

Besides, the collaborative deployment of hybrid energy converter has been verified with high energy conversion ratio, high feasibility, and low extra cost. The anchor of wave energy converter can be used as the fixture of tidal energy converter and even the wave and tidal energy converter can be assembled with the base of ocean wind turbine. It can not only make full use of various kinds of energy in vertical space with different depth, but also can reduce the construction cost and management difficulty.

1.2.2. Disadvantage

However, the same as other natural renewable energy, wave energy and tidal energy are discontinuous and non-dispatchable. It results in that the electricity converted from them has large fluctuation and low transmission efficiency and cannot be directly integrated into the power grid (Widén et al., 2015; Yin et al., 2018). Meanwhile, the large space span hinders the integration of offshore blue energy stations and onshore power grids (Khan et al., 2017; Lewis et al., 2019; Shetty and Priyam, 2022). Lewis et al. believe that the cost of blue energy storage and system control can be greatly reduced as long as the matching problem of power supply and demand is solved (Lewis et al., 2019).

Based on the challenge above, two possible research prospects are found from literatures: (1) reduce the mismatch between discontinuous blue energy and power demand, (2) solve the problem of electricity long-distance transmission between offshore blue energy stations and onshore power grids. For the first problem, some combinations of renewable energy in the ocean are studied to generate stable and controllable power by complementing each other, like the wind-solar, wind-tidal and hybrid wave-tidal energy generation systems. For the second problem, the electricity long-distance transmission can be avoided by using the power directly on the offshore platform like offshore drilling platforms, or by using the power to generate and store hydrogen on the spot as offshore fuel stations for hydrogen-powered ships.

1.3. Blue energy conversion technology

Various attempts have been made in the single wave or tidal energy converter since last century, and many mature designs have been successfully implemented.

1.3.1. Wave energy conversion

In wave energy conversion technology, several main implementations of wave energy converter were summarized based on the output performance and development history, including heaving float device, pitching float device, heaving and pitching float device, oscillating water columns device, point absorber and surge device (Khan et al., 2017). The representative methods and theories of wave energy point absorbers were described, and many instructive conclusions were drawn, such as: the effect of time domain or frequency domain, linear or non-linear on modeling accuracy, the effect of distance and damping on energy capture efficiency and the effect of anchoring method on the output power of the point absorber, etc. (Al Shami et al., 2019). For “traditional” wave energy converter based on mechanical and electrical structures, the studies on device (concept, design, modeling and testing), utilization of specific components (turbine, hydraulic and generator) and mooring systems were reviewed (Falcão, 2010). Complementarily, the output power, power density, cost-effectiveness and robustness of

“new” wave energy converter based on electroactive polymers, triboelectric and other material technologies, such as electromagnetic harvester, electroactive polymers harvester (including dielectric elastomer, piezoelectric, ionic polymer metal composite) and triboelectric nanogenerator, were reviewed (Zhao et al., 2021). In 2004 (Westwood, 2004) and 2007 (Westwood, 2007), inventories of the wave energy converter projects that have been put into production were carried out. The performance indicators and economic benefits of these projects are briefly introduced, providing a useful reference for the transition of wave energy converter from academic research to industrial applications.

1.3.2. Tidal energy conversion

In tidal energy conversion technology, three methods of tidal energy conversion have been applied: tidal barrages, tidal lagoons, and tidal currents (streams) (Shetty and Priyam, 2022). Among them, tidal barrages and tidal lagoons are mostly built onshore to capture the tidal range energy, and their core components are dams that form basins or estuaries, sluices that fill or empty basins, and turbines that convert kinetic energy into electricity (Khan et al., 2017). They have the advantage of long life and high power. However, they are difficult to be popularized due to the impact on the ecological environment and the site selection of the station. Since the power generation principle has many similarities with the current hydroelectric power station, many technologies applied are relatively mature (Khan et al., 2017). Offshore tidal energy converter with tidal currents as the main energy source is divided into three categories: Vertical-axis tidal current turbine (TCT), Horizontal-axis TCT, and Oscillating hydrofoil (Hu et al., 2022). It is difficult to deploy and maintain them currently, but the vast open sea provides great power potential. Therefore, it is essential to improve the reliability and accessibility of offshore tidal energy converter (Westwood, 2004). And for hybrid wave-tidal energy conversion technology, it is easy to combine the tidal energy converter and wave energy converter in terms of deployment and working principles with little adverse effect.

1.3.3. Hybrid wave-tidal energy conversion

Based on the development of single wave energy conversion and tidal energy conversion and inspired by the multiple energy cogeneration in wind, solar, tidal and so on, the hybrid wave-tidal energy conversion became a field that cannot be ignored in ocean.

In order to verify the improvement of the integration of wave energy and tidal energy, some index or factor are proposed. In (Borba and Brito, 2017), the complementarity index is introduced to evaluate the stability of the hybrid energy converter system by describing the power dispersion around the average value. The value is between 0 and 1, and negatively correlated to the working intermittent. In (Zheng et al., 2020), H-factor was proposed to compare the hybrid energy converter and the single modules. $H > 1$ means that the integration contributes a positive improvement in output power or efficiency. $H < 1$ means that more energy loss in the integration worsens the overall performance.

For the HWTEC in (Silva et al., 2023), the complementarity index is 20%–30% higher than single wave or tidal energy converter and the H-factor is 1.27, verifying that the integration improves the performance. Similar conclusions were drawn in common form of output power or efficiency. The maximum simulated power of the HWTEC in (Chen et al., 2022) is 36%–373% higher than single wave energy converter, and the Peak to Average Ratio (PAR) decreases by 70%, making the output power much more stable. The coupling effect between modules in (Cheng et al., 2022) makes the average efficiencies of OB and OWSC increase 60.05% and 93.15% than isolated wave or tidal energy converter respectively.

1.4. Summary

In summary, there have been many reviews on single wave or tidal

energy conversion technology summarizing the macro status and prospects, technology development and so on. Some studies have proved that HWTEC have higher output power, energy harvesting efficiency and power stability than single wave or tidal energy converter, but no review has been found to systematically compare and summarize them. Therefore, this paper will focus on the technical review of the current hybrid wave-tidal energy conversion technology, including the device design and working principle, the dynamics analysis methods and the testing methods widely used currently. Meantime, technologies for single tidal energy or wave energy conversion that is potential to be utilized in futural hybrid wave-tidal energy conversion will also be mentioned. Lastly, current technical gaps and potential research directions in future work are proposed and prospected.

2. Hybrid wave-tidal energy conversion technology

The discontinuity of waves and tides determines that the single wave or tidal energy has poor output stability, and cannot be integrated into the power grid and widely used. In order to improve this situation, some studies attempt to couple and superimpose tide and wave energy, improving output power and stability through the complementarity (Clemente et al., 2021; Silva et al., 2023). Besides, the hybridization between blue energy converters can also reduce the cost of equipment manufacturing and maintenance and the impact on marine ecology, which has been verified in the research of wind-wave co-generation farm (Clemente et al., 2021).

Currently, the average efficiency of tidal energy converters in real ocean is 35%–40% (Si et al., 2022; Silva et al., 2023). The average efficiency of wave energy converters in simulation and lab tests is 2%–65% (Aderinto and Li, 2019; Zhang et al., 2021), but in real ocean, 20%–45% is common (Aderinto and Li, 2019; Zhang et al., 2021; Silva et al., 2023). As mentioned before, waves have two-dimensional motion in the vertical and horizontal directions, and tides mainly move in the horizontal direction. Therefore, the energy converter able to capture the two-dimensional motions is potential to improve the efficiency of energy capture per unit area (Khan et al., 2017).

2.1. Designs and principles

Based on the coupling effect between the wave and tidal energy capture modules, the HWTECs can be classified as non-coupling devices and coupling devices.

2.1.1. Non-coupling devices

The non-coupling HWTECs are established by switching working modes of one energy capture module or binding two or more energy capture modules that work separately with no or negligible coupling effect.

The hydro-kite like energy converter was proposed, consisting of a hydrofoil in ocean and an energy conversion module fixed on board (Fig. 1) (Yin et al., 2018). The energy conversion module is composed of reel, permanent magnet generator and necessary grid-connected circuit. The NACA 63–424 series foil is used to design the cross-section of the hydrofoil, which is with higher resistance to cavitation and can provides sufficient structural strength and high lift-to-drag ratio. Cables are used to connect the hydrofoil and the energy conversion module. Since it works in two working modes (i.e., wave mode and ocean current mode) instead of by multi-modules, there is no coupling effect in the device. In wave mode, the hydrofoil floats on the water surface and moves up and down driven by the ocean waves, and then the reel is driven to rotate by the cables, thereby driving the permanent magnet generator to work. In tidal current mode, the hydrofoil is submerged and keeps sinking with the action of the fluid pressure difference, dragging the cable to drive the permanent magnet generator. The above process is similar to that of flying a kite, hence the name hydro-kite. Since the converter sails with the ship, technicians can adjust the angle of attack in time according to

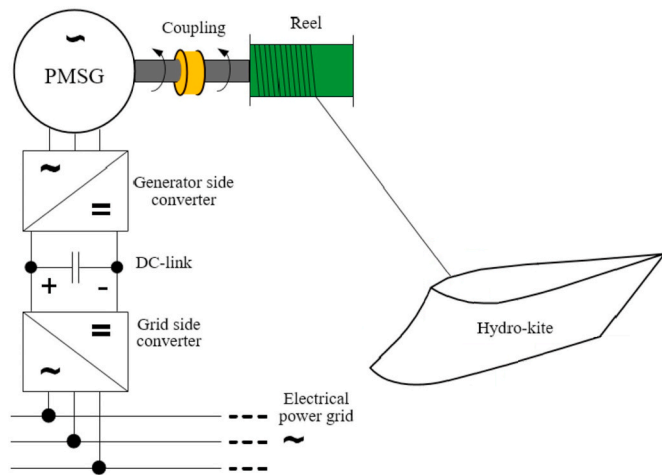

Fig. 1. The hydro-kite energy converter (adopted from Yin et al., 2018).

sea conditions through active control to improve energy capture efficiency. In extreme weather, it can also be lifted above the water surface to avoid damage from strong wind and wave, which greatly improves the life of the converter. Unlike fixed-point energy converter anchored in the ocean, the power from the hydro-kite like energy converter can be directly used by the ship, hence the difficulty and cost of electricity long-distance transmission are avoided.

Many studies on deployment, working frequency, pitch angle and parameter optimization of different hydrofoil-driven energy converters prove that it is feasible to use hydrofoil as the energy capture unit in wave and tidal energy converter (Peng and Zhu, 2009; Xie Y. et al., 2014; Zhu and Peng, 2009; Zhu, 2011).

By comparing the research methods and output indicators of different wave and tidal energy converters, the oscillating buoy and the vertical-axis turbine were selected as the wave energy and tidal energy capture module respectively to design the HWTEC (Fig. 2) (Silva et al., 2023). Two oscillating buoy modules and a vertical-axis turbine module are independently installed side by side without coupling effect on the base fixed on the seabed, three generators are needed and output power

separately. The turbines rotate when the tidal current comes and drive the generators through the gear box. The vertical-axis turbine here can capture the tide current in all directions, without additional parts or controls to ensure that it always faces the tide. The reciprocating linear motion of the buoy is converted into the rotation of the input shaft through the crankshaft, thereby driving the generator. The device can output an average power of 192 kW and have the efficiency of 31.5%–32.6%. In the integration evaluation, the complementarity index is 0.796, compared with 0.621 of single wave energy converter and 0.648 of single tidal energy converter. However, the working bandwidth of the crankshaft mechanism is very narrow. The structural parameter of the crankshaft needs to be matched with the frequency and displacement of the input motion, otherwise it is very easy to be stuck at the dead point or vibrate between two dead points, making the generator unable to work continuously and stably. Further research and improvement are needed to make it more suitable for the complex ocean working conditions.

A hybrid ocean energy harvester was proposed based on overtopping module and oscillating water column module, where tidal turbine and air turbine are applied to capture the tidal range energy and wave energy respectively (Fig. 3) (Calheiros-Cabral et al., 2020). The two modules work independently without coupling, and the output power is the sum of the power from them. The oscillating water column module is common in wave energy capturing, which has a cavity with large cross section for water oscillating, and a pipe with small cross section for air flowing (Falcão and Henriques, 2016). The up and down motion of waves changes the air pressure in the cavity and make air flow in a

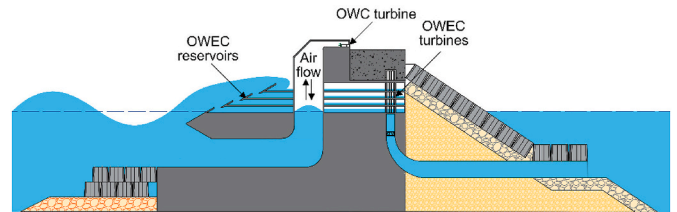

Fig. 3. The hybrid breakwater integrated wave energy converter (adopted from Calheiros-Cabral et al., 2020).

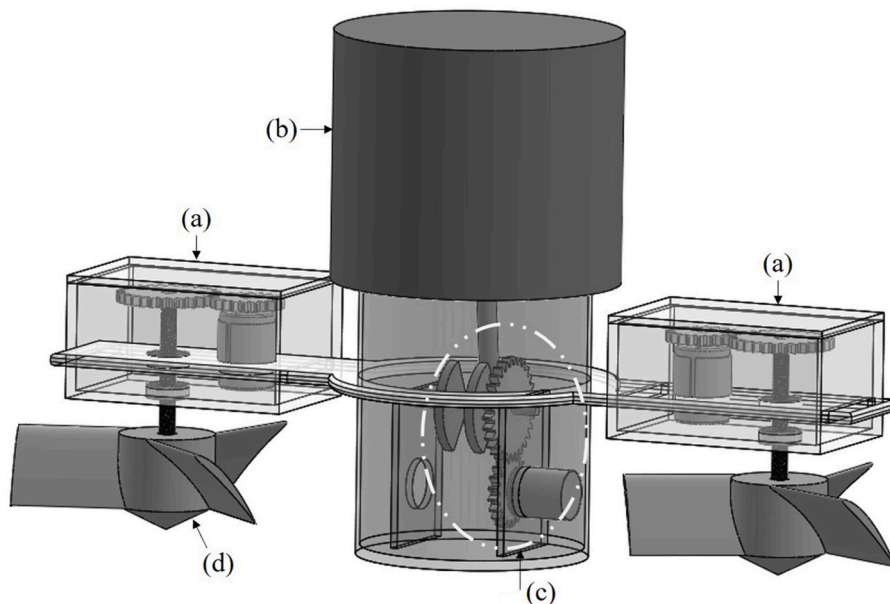

Fig. 2. The hybrid ocean energy converter based on the oscillating buoy and the vertical-axis turbine (adopted from Silva et al., 2023). (a) Gear box and generator. (b) Floating-point absorber. (c) Crankshaft, gearbox and generator. (d) Vertical axis turbine.

higher speed in pipe, driving the turbine. Similarly, the oscillating water column converter based on piezoelectric materials has also been studied, where the turbine is replaced by piezoelectric materials, and can generate electricity through the deformation caused by the air pressure changes (Du et al., 2021, 2022a, 2022b). Since there is no moving part in the energy converter based on piezoelectric materials, it has better reliability than turbines, but significantly lower output power. The overtopping module with tidal current turbine is mainly used to capture tidal energy. At flood tide, the seawater enters the reservoir over the wall. At ebb tide, the water in the reservoir with potential energy flows back to the sea through the channel with turbine. The output power depends on the velocity of flow through the turbine during the tidal change and the storage capacity of the reservoir. This module has been verified on “WaveDragon”, a wave energy converter that has been successfully connected to the power grid. Differently, since the overtopping module in (Calheiros-Cabral et al., 2020) is fixed on the breakwater instead of floating in waves, it can capture not only the mechanical energy in the wave but also part of the kinetic energy in the tide. At the same time, since the energy converter is built on the port breakwater, part of the impact of the water is dispersed and converted into electricity, realizing the dual functions of breakwater protection and hybrid wave-tidal energy capture.

Based on the development of single wave or tidal energy conversion, the non-coupling device is simple to realize and low in cost by binding some mature designs. However, the incompatibility and the negative impact between different modules are rarely reported. For example, the optimal design for the hydrofoil in wave mode may be not suitable for it in tidal current mode; the tidal energy capture module may change the hydro dynamics of wave energy capture module, causing efficiency reduction. In order to ensure the marginal benefits, better combination needs to be explored and studied in the future.

2.1.2. Coupling devices

Compared to non-coupling devices, the modules in the coupling HWTECs will affect each other in working process. Specifically, the coupling effect makes the dynamic response of one of the modules not only affected by the input but also the dynamic response of other module (s).

A wave-current hybrid energy converter is designed based on the bevel gear mechanical motion rectifier (Fig. 4) (Chen et al., 2019; Chen

et al., 2022; Jiang B. et al., 2019; Jiang B. et al., 2020). The mechanical motion rectifier has potential in the mechanical energy capture from reciprocating motion such as ocean waves and mechanical vibrations, which has attracted much attention in the past years. Different types of mechanical motion rectifiers were designed, verified, and applied in energy harvesting (Liu et al., 2017; Martin et al., 2020; Xie Q. et al., 2020; Yang et al., 2019; Yang et al., 2021; Zhang Z. et al., 2016). Unlike previous single input shaft bevel gear rectifiers applied to capture the single energy source, the bevel gear rectifier in HWTEC requires two input shafts to capture the reciprocating linear motion of waves and the unidirectional flow of tidal currents respectively, and outputs them to a generator, realizing hybrid capture of the two kinds of energy together. The oscillating buoy and the horizontal axis turbine are selected as the capture units of wave energy and tidal current energy respectively, which are verified simple, reliable and relatively mature in their respective fields. The converter is anchored in seawater, and the oscillating buoy and the horizontal axis turbine drive two input shafts respectively. The input shaft with a larger angular velocity will engage with the output shaft and drive it rotate in one direction, while another input shaft will disengage due to the overruning phenomenon of the one-way bearing. Therefore, the converter has four working modes, corresponding to different wave and tidal current conditions. Through this mechanism, only one DC generator is needed to selectively output the higher speed, which can be expressed as:

$$\omega_o = i_{MMR} \max(\omega_{i1}, \omega_{i2}) \tag{5}$$

where ω_o is the angular velocity of the output shaft, i_{MMR} is the transmission ratio of the bevel gears in the mechanical motion rectifier, ω_{i1} and ω_{i2} are the angular velocity of two input shaft connected to the buoy and turbine respectively. In this design, the output velocity depends on the larger velocity of the turbine and the buoy, making only one of the wave and tidal energy can be effectively converted. Considering the different variability of wave energy and tidal energy, this mechanism can make full use of the complementarity between them and increase the stability of the output power. The simulation shows that as the wave height changes from 0.17 m to 0.06 m, the power promotion increased from 36%–373% than single wave energy converter, verifying the positive effect of the coupling between the turbine module and the buoy module. The output power of 4.05–15.97 W is obtained based on above conditions in simulation. Besides, the Peak to Average Ratio (PAR)

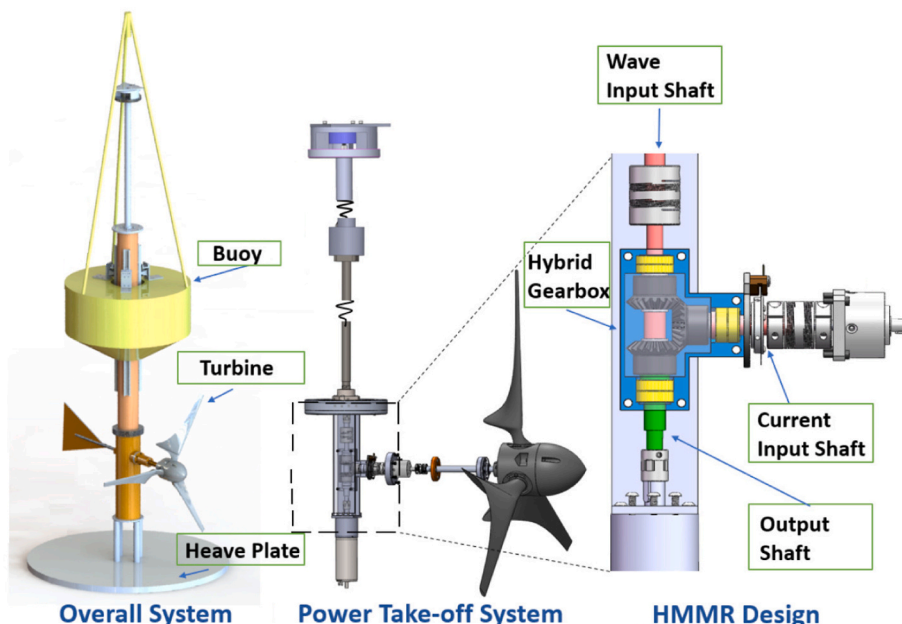

Fig. 4. The wave-current hybrid energy converter based on MMR (adopted from Chen et al., 2022).

decreases by 70%, which means that it can work in a much more stable state and output power with smaller fluctuation. However, similar to the design in (Yin et al., 2018), a considerable part of the power will be discarded.

A wave-tidal current hybrid energy converter based on a horizontal cylinder and a swing plate, consists of a fixed platform with the gearbox and a seesaw-like movable component (Fig. 5) (Park et al., 2022). The horizontal cylinder and the pendulum plate are installed at one end of the seesaw, and a counterweight is installed at the other end. Driven by the heaving motion of the ocean waves, the rotation of the paddlewheel-like horizontal cylinder and the pitching motion of the seesaw are transmitted to the input shaft through the belt drive and the gear drive respectively, so as to capture the potential energy of the incident wave. Driven by the tidal current, the oscillations of the swing plate are transmitted to the input shaft through the leverage structure and the rack-and-pinion drive, so as to capture the kinetic energy of the tidal current. It is worth noting that one-way bearings are also applied, so the velocity of the output shaft also depends on the largest angular velocity among the three inputs velocity, satisfying:

$$\omega_o = \max(\omega_{hc}, \omega_{ss}, \omega_{sp}) \tag{6}$$

where ω_o is the angular velocity of the output shaft, ω_{hc} is the equivalent angular velocity of the horizontal cylinder, ω_{ss} is the equivalent angular velocity of the seesaw and ω_{sp} is the equivalent angular velocity of the swing plate. The yawing plate commonly used on wind turbines is also added to the design as a steering device, which can deflect the direction of the converter to the current, so as to make full use of the energy.

Similar pendulum plate structures have also been reported in many studies of single wave or tidal energy converters, including for capturing the undulating motion of waves (Chen W. et al., 2023; Fang Z. et al., 2021; Fang Z. et al., 2023) and the horizontal motion of tidal currents (Gomes et al., 2015; Henriques et al., 2011). The obvious feature of the pendulum plate is that the length is much greater than the radius of the shaft, so a large torque can be generated on the shaft under the drive of a small buoyancy (or hydrodynamic force) due to the large moment arm. With an appropriate transmission device, a generator with a great damping can be driven and generate a large output power, which has been verified in many wave energy converters. However, this advantage is not obvious in the tidal energy converter, not only because the swing

plate is not as efficient as the turbine, but also because the continuity of the swing is far less than the rotation of the turbine, which causes great energy loss and limits its output power.

In this paper, it is mentioned that the overrunning phenomenon of the one-way bearing can avoid the halt of the converter caused by the direction change of the tidal current, but further research on its non-linear effect is not carried out.

There are some studies on two degree-of-freedom wave energy converters, aiming to capture and utilize the vertical undulation motion of ocean waves and the horizontal surge motion of tidal currents. In the multi degree-of-freedom hybrid system, an oscillating wave surge converter (OWSC) and two oscillating buoys (OB) are integrated on a semi-submersible platform (Fig. 6) (Cheng et al., 2022). The buoys in the OB modules reciprocate up and down in the waves, driving the generator inside the cylinder through the rack and pinion mechanism. The cylinders in the OWSC module pitch around the hinge at the bottom to drive the generator through the rack connected to the side. The fin-like plate is also used to adjust the direction of the converter to make it face the tide actively. Although the modules with independent generators work separately as well, but unlike the modules in (Silva et al., 2023), the OB modules and the OWSC module are embedded together and affect each other. Specifically, when the angle between the OWSC module and the vertical direction is β , and the rising height of the buoy in OB module is h , according to trigonometric functions, the displacement of the buoy in OB can be calculated as $h/\cos\beta$, which means that the effective working stroke in this case is larger than when working separately. Therefore, the coupling between modules makes the converter capture more energy. In the pool tests of the prototype, maximum efficiency of 58.05% is obtained. Compared with single OB and OWSC module, the average efficiency increases 60.05% and 93.15%, verifying the improvement caused by the coupling effect between modules. Similar two/multiple degree-of-freedom converters are mentioned in (Fang H. et al., 2020; Gao and Yu, 2018), by coupling the horizontal displacement (or pitch angle) generated by tidal currents and the vertical displacement generated by waves, the effective stroke of the converter is increased, hence the output power.

Please note that the two degree-of-freedom converter that captures the motion in two directions in ocean is different from the two degree-of-freedom converter that capture the motions in one direction. In the former, two movable modules are connected in parallel in the

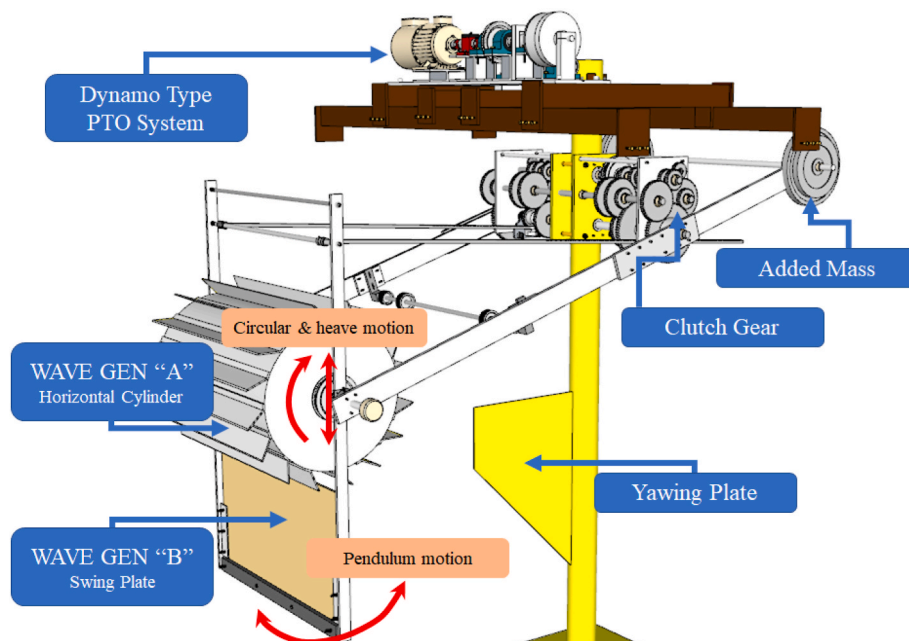

Fig. 5. The wave-tidal current hybrid energy converter based on horizontal cylinder and swing plate (adopted from Park et al., 2022).

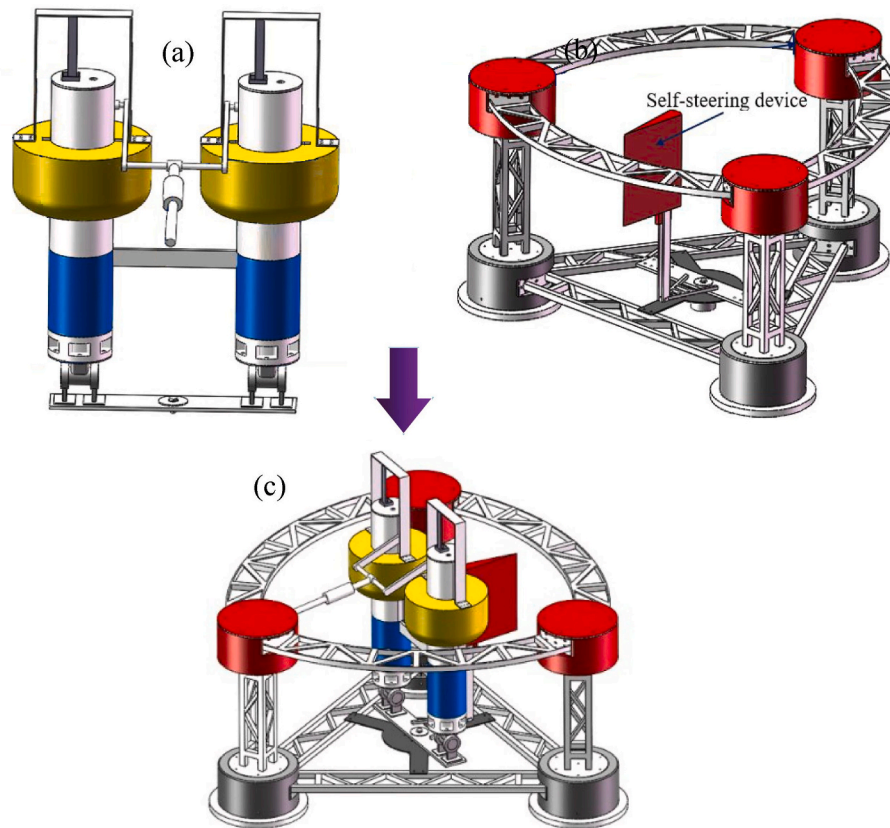

Fig. 6. The multi degree-of-freedom hybrid system based on oscillating wave surge converter (OWSC) and oscillating buoys (OB) (adopted from Cheng et al., 2022). (a) The MDOF-WEC system. (b) The semi-submersible platform. (c) The whole integration.

orthogonal direction and can make full use of the energy in two directions based on the synthesis of motion, which improves the energy capture rate. While in the latter, two movable modules are connected in series in the same direction. According to the law of conservation of energy, the total energy captured will be reduced due to more transmission links, which makes this type of two degree-of-freedom converter is more suitable for vibration reduction with energy capture as an additional effect, like the converter in (Nico et al., 2020). In addition,

please note that not all converters analyzed by two degree-of-freedom model are two degree-of-freedom converters. In order to improve the modeling accuracy, and considering the effect of the input, environment and material stiffness on the device, it is closer to the actual working conditions to analyze the motion characteristics by using a two degree-of-freedom model. For example, two degree-of-freedom model is established, where the energy converter is a single degree-of-freedom device and the main structure (the vehicle) is considered as another

Table 1
Features and key performances of HWTEC.

Category	Source	Features	Scale	Performance	
				Output power	Efficiency
Non-coupling	Yin et al. (2018)	Hydro-kite like. Two working modes. Non-coupling.	Sectional area: 1 m ² . Length: 1 m.	Tidal mode: >7.6 J/kg. Wave mode: <750 W.	/
	Silva et al. (2023)	Oscillating buoy and vertical-axis turbine.	Turbine radius: 5 m. Turbine height: 4 m. Buoy diameter: 10 m. Breakwater length: 20 m.	Instantaneous: 50–320 kW. Average: 192 kW.	31.5%–32.6%
	Calheiros-Cabral et al. (2020)	Overtopping module and oscillating water column module.		Rated: 80 kW. Annual average: 4 kW/m.	Overall: 44.4%. Wave-to-wire: 27.3%.
Coupling	Chen et al. (2022)	Coupled by bevel gear mechanical motion rectifier.	Turbine radius: 0.5 m.	Simulation: 4.05–15.97 W. Pool test maximum: 4.21 W.	/
	Park et al. (2022)	Horizontal cylinder and swing plate. Coupled by clutch gears.	Sectional area in flow direction: W 2 m × H 3 m.	Average: ~12.5 W.	/
	Cheng et al. (2022)	Muti degree-of-freedom. Oscillating wave surge converter (OWSC) and oscillating buoys (OB).	OWSC radius: 0.975 m. OWSC height: 10.5 m. OB radius: 2.1 m. OB height: 3.3 m. Prototype scale: 1:15.	/	Maximum: 58.05%

degree of freedom (Xie L. et al., 2020).

The advantages of coupling effect between modules are supplement and increased, which has great potential to be developed. In some studies, the module with larger output power engages with the generator due to the coupling effect, therefore the supplement between modules makes the output more stable. In some studies, the coupling effect can increase the output power and efficiency by the motion synthesis or superposition of speed. While the modeling of coupling device will be more complicated than non-coupling device undoubtedly.

2.1.3. Summary

The features and key performances of typical HWTEC are summarized systematically as Table 1.

In summary, for the design of HWTEC, many designs and principles that have been verified in single wave or tidal energy converting are still applicable. For wave energy capture module, due to the horizontal distribution of the wave, there are many types of devices and energy conversion principles that can be studied. For tidal current capture module, due to the longitudinal distribution and directionality of the tidal current, turbines and the vertically deployed wing plates are the most studied. Although each type has its own advantages and disadvantages, the wave energy converter based on floating buoy and permanent magnet generator currently seems to have great comprehensive potential in terms of cost, output power and feasibility.

In futur works, for the non-coupling HWTEC, the improvement of power and efficiency in each single energy capture module is still the key point, and the miniaturization should be also considered to improve the capture rate of energy per unit volume (i.e., capture more). While for the coupling HWTEC, further revelation of the coupling theory and optimization of the coupling method are important to improve the conversion efficiency (i.e., convert more).

2.2. Methods of modeling and simulation

According to the system characteristic, they can be classified as linear system and non-linear system.

2.2.1. Linear system

System models of wave mode and tidal current mode are established (Yin et al., 2018). In wave mode, the hydrofoil is semi-submerged. considering the shape of the hydrofoil, the radiation force of the water and the hydrostatic force, the dynamic equation of the hydrofoil is established. Hydrodynamic forces and coefficients are calculated with the software package WAMIT, and then the tension on the cable in wave mode can be obtained. In tidal current mode, the hydrofoil is fully submerged. The dynamic equation of the hydrofoil based on the gravity, buoyancy force, drag force and lift force from the ocean current and the tension force from the cable are established, and then the tension on the cable in tidal current mode can be obtained. The rotational speed of the generator can be calculated from the torque on the reel generated by the tension of the cable. Finally, the output voltage and power are obtained. The modeling process can be summarized as “input force - velocity - voltage” and presented as

$$F = ma + cv + kx \quad (7)$$

$$\omega = \sigma v \quad (8)$$

$$U = K\omega \quad (9)$$

where F is the input force, m is the equivalent mass of the moving parts, c is the damping coefficient k is the stiffness coefficient (if there is an elastic component), x , v and a are the displacement, velocity and acceleration of the moving parts respectively, ω is the angular velocity of the generator, σ is the transmission ratio between input and output shafts, U is the output voltage and K is the electromotive voltage

coefficient of the generator. With easy-to-understand principle, clear logic and high reliability, it is adopted in many studies on the dynamic modeling of wave or tidal energy converters, especially in the analysis of linear systems in time domain. It is used to modeling the single-floating body wave energy converter (Pan et al., 2022; Xie Q. et al., 2020) and the double-floating body wave energy converter (Dai et al., 2017), where the ideal input conditions (e.g., sinusoidal input assumption or linear input assumption), the force balance equation of the input parts (i. e., energy capture mechanism, e.g., pendulum or turbine) based on Newton's second law are proposed to obtain the velocity of energy transfer mechanism (e.g., the cables, shafts or gearboxes) and the output voltage of generators. Meanwhile, the energy conversion efficiency can also be easily calculated in above process. This method is also applicable to partially predictable non-linear systems, which will be elaborated below.

The dynamic model of the mechanical and electrical system of the HWTEC was established with the bond graph (BG) modeling method (Fig. 7) (Silva et al., 2023). Based on the law of conservation of energy, the physical quantities of the entire device are unified into four state variables (namely, potential variables, flow variables, displacement variables, and momentum variables) in BG modeling method, and all related according to the energy flow in the mechanical and electrical system. It can present the logic of the dynamic equation clearly and vividly and help to establish the preliminary program framework for subsequent simulations. In the simulation verification, the similar system in (Chen et al., 2019; Chen et al., 2022; Jiang B. et al., 2019; Jiang B. et al., 2020) was modeled and simulated with BG modeling method and compared with the original results. The high consistency of the results verified the reliability and accuracy of BG modeling method. Then it was used to simulate the HWTEC proposed in this study. The results showed that the combination of the vertical-axis turbine and oscillating buoy can increase the energy output by 50% and the output stability by more than 20% without increasing the occupied area. And the oscillating buoy module has more power but lower efficiency than the vertical-axis turbine module, which verified the complementarity between them. In summary, BG modeling method is a visible modeling method based on dynamic general equations (i.e., Newton's second law, D'Alembert's principle and Lagrange equation), and can be used as an auxiliary method to clearly show the energy flow in system modeling.

Although the modules in the converter in (Sinha et al., 2019) are installed together, they work independently without interfering with each other, and the total output power is the sum of the power of each module. Therefore, the methods commonly used in single wave and tidal energy converters in time domain are used to analyze the oscillating water column (OWC) module and the overtopping wave energy converter (OWEC) module respectively. For OWC, the motion equation of the water in the cavity under the joint action of atmospheric pressure, exciting force and radiation force from wave is established, so as to calculate the pressure ratio on both sides of the air turbine and the output power. Although the core of the above process is also based on dynamic general equations, it is difficult to accurately obtain the hydrodynamic coefficients involving additional mass, radiation damping and exciting force. The method commonly used is to simulate it in computational fluid dynamics (CFD) software like ANSYS AQWA (ANSYS, 2013). In previous studies, the free water surface in cavity is usually regarded as a piston or a massless disc in the simulation and the non-linear effect of wave motion is not considered. Currently, BEM codes is utilized to simulate the water surface behavior to improve the accuracy of simulation (Sinha et al., 2019). For OWEC, the relatively mature WOPSim (Wave Overtopping Power Simulation) (Meinert et al., 2008) tool is introduced to simulate the output performance with the various ocean conditions. WOPSim tool is specially developed by Aalborg university for OWEC performance simulation. The simulation results show that, driven by waves with a wave height of about 0.8m, the pressure ratio on both sides of the air turbine can be maintained below 0.04 and the peak and average output power of the OWC module is close

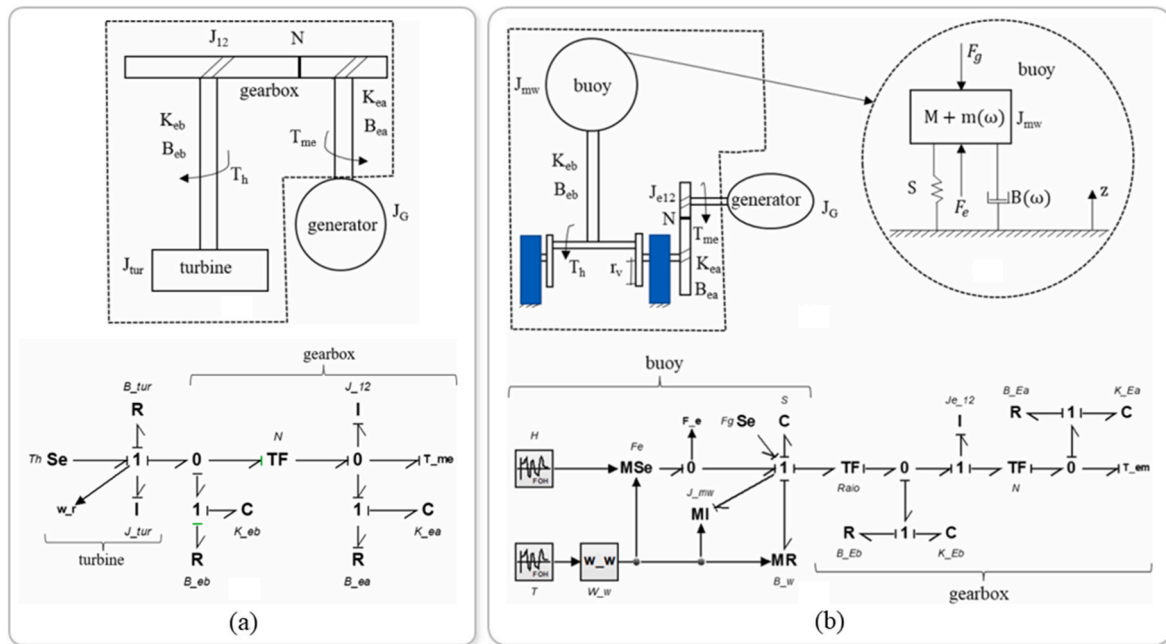

Fig. 7. The bond graph (BG) modeling (adopted from Silva et al., 2023). (a) The BG modeling of the vertical-axis turbine module. (b) The BG modeling of the oscillating buoy module.

to 10 kW and 4 kW respectively. The total output power of tidal current turbines in different reservoir can reach 15 kW. According to the area of 600 m², the peak output power density of the HWTEC is close to 0.04 kW/m². Since the two modules in this study has a weak coupling and have little effects to each other, the modeling methods for different modules in it can be referred in most studies on HWTEC based on simple superimposed modules.

The six cylinders of the platform are placed around the energy capture modules, causing great disturbance to the incoming waves (Cheng et al., 2022). In order to improve the reliability of the simulation, the realizable k-ε turbulence model, which has been successfully applied to many simulations of the interactions between ocean waves and structures, and 3D numerical tanks were built to simulate water interaction and energy conversion. And the volume of fluid (VOF) method is used to calculate the height of the free surface. The moment balance equation of the OWSC module and the force balance equation of the OB module are established to characterize their dynamic responses, respectively. The input wave energy is calculated through the wave power formula and the output power of the HWTEC is directly solved through the energy method. Then the conversion efficiency can be obtained. The tank tests of the scaled-down prototype are carried to verify the modeling and simulation. The results show that the OWSC module driven by the water flow swings around the hinge to capture tidal energy and the output power has little correlation with the wave height, while the OB modules move up and down driven by waves to capture wave energy and the output power has a strong correlation with the wave height. In addition, the coupling resonance effect between the two parts becomes more prominent as the wave height increases, which is beneficial to the improvement of the efficiency of the device. The efficiency calculation method used in this study is widely used for theoretical power and efficiency calculations in modeling and simulation, which has been seen in many studies. Since the efficiency here is the ratio of output power to total power in the water, it reflects the ability of the device to capture and convert energy and the value is generally relatively small. Differently, the conversion efficiency obtained by the ratio of output power to input power to the device reflects the ability of the device to convert energy, which can be directly measured in experiments, and the value is generally relatively large.

In summary, for the wave energy capture module, the dynamic equation is mostly used for modeling, while for the tidal energy capture module, the finite element simulation based on CFD software is mostly used for analysis. The energy capture modules can be modeled separately in above linear methods since the weak coupling between modules can be neglected. Therefore, it is simple and suitable for the dynamic analysis of most linear HWTECs. However, for non-linear system with strong coupling, methods with higher reliability are necessary.

2.2.2. Non-linear system

The dynamic model and the fluid dynamics simulation based on CFD software were established to analyze the HWTEC (Chen et al., 2022; Jiang B. et al., 2020). In the dynamic modeling of the oscillating buoy module in (Chen et al., 2022), it is simplified as a single degree-of-freedom system and the force balance equation of the body is established to calculate the input torque or force. With the assumption of ideal rigid anchoring, the simplification is acceptable since it is easy to solve and with small error. However, the HWTEC in (Jiang B. et al., 2020) floats in water with a submerged plate instead of fixed by a rigid anchor. Since, the buoy and the other parts constitute a two-body structure, a two degree-of-freedom vibration system model is established, and the equivalent damping and equivalent mass are calculated and applied to the establishment of the force balance equation. In the analysis of the horizontal axis turbine module, fluid dynamics simulation was adopted to solve the torque on the turbine, which is a relatively mature and widely used method (Chen et al., 2022; Jiang B. et al., 2020). Therefore, the modeling process of “input force - velocity - voltage” mentioned in Eqs. (7)–(9) is still adopted in the modeling of the non-linear dynamic response, but the solution of the non-linear process is the key point. The transmission module of the energy converter in (Li et al., 2020; Liu et al., 2017; Li X. et al., 2022; Martin et al., 2020; Yang et al., 2019) has non-linear process, i.e., the overrunning of one-way bearings. The assumption of sinusoidal input makes the stable working state show a strong repeatability. Similar processing methods are used in these studies: the linear stage and the non-linear stage are modeled as piecewise functions. Specifically, the dynamic response of the non-linear stage is only affected by the characteristics of the mechanical components (i.e., damping and inertia), which can be presented as constants.

By setting the final state of the linear stage as the initial state of the non-linear stage, the velocity response of the non-linear stage can be obtained as an explicit function from a differential equation shaped like

$$A \frac{dx}{dt} + B \frac{d^2x}{dt^2} = 0 \quad (10)$$

where A and B are constant polynomial. While in (Chen and Yang, 2023; Li Q. et al., 2021; Yang et al., 2021), since the inertia of some mechanical components are variables and affected by its own current velocity, the non-linear response is more complex. Therefore, the velocity function is expressed as implicit function shaped like

$$C \frac{dx}{dt} \left[D + \left(\frac{dx}{dt} \right)^2 \right]^2 + E \frac{d^2x}{dt^2} = 0 \quad (11)$$

where C , D and E are constant polynomial. It is more difficult and boundary condition is needed in calculation. At present, sinusoidal input assumption is necessary to solve the non-linear response. Once the random wave input is used, the velocity function can only be solved iteratively with mathematical software.

In the modeling methods mentioned above, since the two modules are coupled by a mechanism with non-linear process, the output performance is not only affected by the characteristic of each module, but also the coupling effect between modules. Based on the dynamical general equation in the time domain, the properties of the non-linear mechanism need to be considered in the modeling. Besides, since the prediction of the motion of the non-linear mechanism depends on the continuous input signal, the ideal continuous input assumption is necessary in modeling, which determines that the model of coupled system is far from the real working conditions and can only be used for feasibility analysis in the early stage of studies. Experimental data is needed as verification in the evaluation of output characteristics in engineering practice.

The discretization used in modeling is reported in a few hybrid wind-wave energy converters, where acceleration measured is discretized to get a clean signal (Jiang C. et al., 2023). Furthermore, discretization can avoid the dependence of continuous input signal in modeling, making random wave signal able to be introduced in discretized modeling. Discretized modeling method has potential to significantly reduce the difference between simulation and real ocean condition, but in hybrid wave-tidal energy conversion is not found.

2.2.3. Summary

In hybrid wave-tidal energy conversion technology, for the system without coupling, the linear system modeling method is still applicable. However, HWTEC with coupling is potential in output power and efficiency and attracting attention. As the coupling effect between energy capture modules increases in the future, the non-linear response will inevitably become an important factor affecting the modeling accuracy and difficulty. Therefore, it is necessary to develop a mature modeling method with consideration of the non-linear dynamic response based on the dynamic equations. And if necessary, system models based on numerical calculation software needs to be established and developed as a platform to iteratively analyze the non-linear model.

In summary, the modeling method based on dynamical general equation and the hydro dynamic finite element simulation are the most used methods for the analysis of wave energy converters and tidal energy converters respectively. However, the two methods are independent in terms of implementation and presentation of results. When they are used for HWTEC with strong coupling effect, the coupling between them cannot be accurately considered at present. Therefore, an algorithms or software platform that can integrate the results of hydro dynamic finite element simulation and the dynamics modeling is essential in the future.

2.3. Testing methods

As an energy conversion device, the most basic and important technical parameters of a HWTEC are efficiency, output power and stability. It can learn from the research experience of the single wave or tidal energy converter in many aspects of experimental tests, including test indicators and test methods.

There are three most widely used test methods of HWTEC: Dry lab test, Wave pool test and Ocean test.

2.3.1. Dry lab test

The dry lab test is carried out entirely in the dry laboratory (Fig. 8). The electric motors or hydraulic actuators are usually used to drive the HWTEC work with sinusoidal or uniform motion, simulating the movement of waves or tides. The tension/pressure sensors or torque sensors are used to measure the input force or torque. Necessary circuits and an oscilloscope or voltage/current sensor are used to measure the output voltage and power. Besides, a charging test of a battery or an energy supply test of an electrical appliance such as an LED is usually carried out as supplement to visually characterize its performance (Fig. 8(a)(b)). Since this method has low requirements for equipment, fully controllable input conditions, high repeatability, and can accurately and clearly obtain the high-resolution output under regular input, it is widely used in the feasibility and performance test of small-scale device in the early stage of studies. However, since the input are artificially set ideal values rather than real water dynamics, it is not suitable for the real working conditions simulation test of large-scale device in the late stage of studies. A servo hydraulic machine is used to carry out the dry lab test (Fig. 8(a)), which can measure the displacement and the force with high precision while driving the wave energy converter (Li et al., 2020). And the data acquisition system is used to collect the output voltage. The same test equipment is adopted in (Yang et al., 2021) and an oscilloscope is used for voltage measurements (Fig. 8(b)). In (Wu et al., 2023), a test platform is built by using rotor motors, torque sensors, oscilloscopes and so on (Fig. 8(c)).

For hybrid wave-tidal energy conversion technology, the dry lab test is also a good choice. However, since the coupling between multiple input signals cannot be accurately artificially simulated, more actuators and sensor will be necessary to simulate the multi-input and measure every force, torque and voltage. Currently, due to the lack of research on HWTEC, the construction of platforms is rarely reported.

2.3.2. Pool test

The pool test is also carried in the laboratory, but a large-scale artificial pool is needed. The pool for wave energy converters testing is usually equipped with a wave maker at one end. Driven by the motor, the wave maker can push the water according to the parameters set to generate waves, thereby simulating the waves in the ocean. Another type of pool for tidal current energy converters testing is equipped with a beam that can move horizontally above the pool. The tidal energy converter will be fixed on the beam and sunk in the water. The tidal energy converter carried by the beam moves in the still water to simulate the flow of the tidal current. The pool test is performed (Fig. 9(a) and (b)) after dry lab test (Li et al., 2020; Wu et al., 2023). Towing test and rotating arm test are carried out and compared for horizontal axis turbine (Fig. 9(c)) (Wang et al., 2022). Compared with the dry lab test, the pool test not only retains the advantages of accurate measurement and controllable input, but also is closer to the natural working conditions. Since the real hydro dynamics can be simulated, the pool test is suitable for optimization and robustness testing in the early or middle stage of studies but waterproof of the device tested is highly required. For the HWTEC, the pool test can reflect the interaction between different inputs, so it is currently the most used test method. The pool tests are carried out on the prototype in to evaluate the performance of the HWTEC (Fig. 9(d)) (Park et al., 2022). It verifies that the combination of wave and tidal energy can improve the capture width ratio effectively.

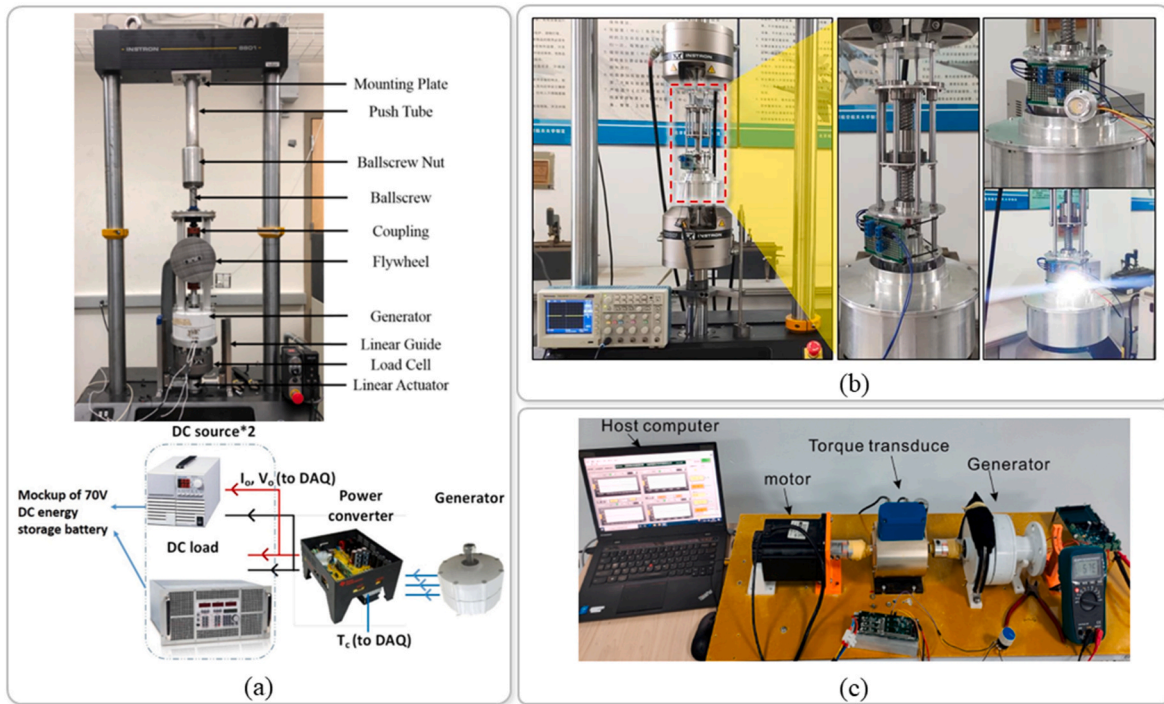

Fig. 8. Some reported dry lab test bench setups. (a) The servo hydraulic machine and battery charging test (adopted from Li et al., 2020). (b) The servo hydraulic machine and LED test (adopted from Yang et al., 2021). (c) Construction of a simple test bench (adopted from Wu et al., 2023).

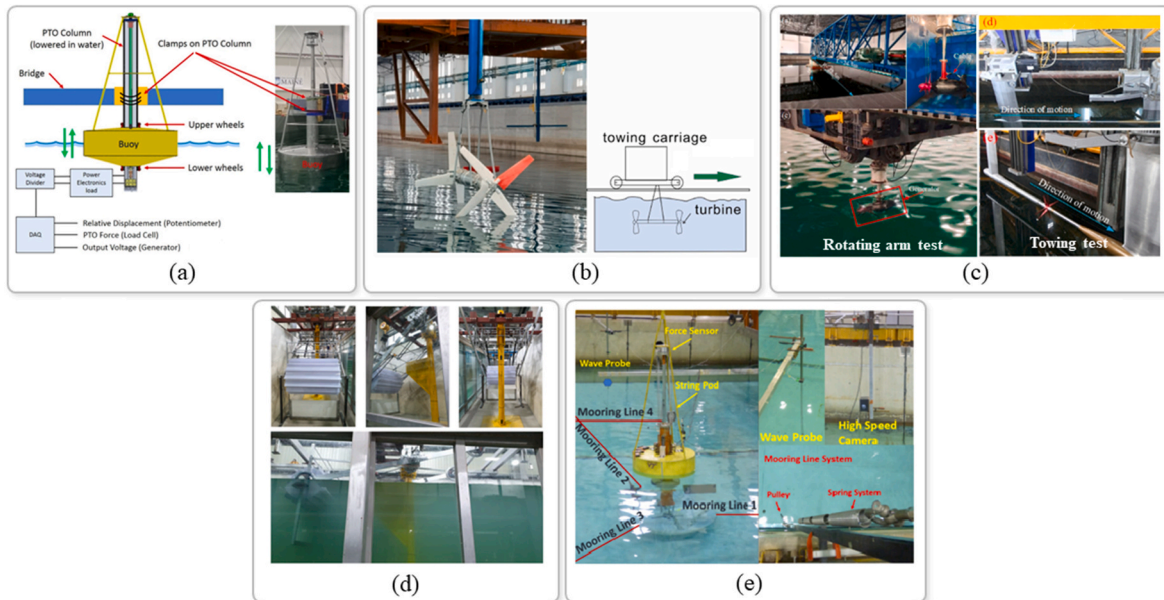

Fig. 9. Some reported pool test setups. (a) Pool test for wave energy converter (adopted from Li et al., 2020). (b) Towing test for tidal energy converter (adopted from Wu et al., 2023). (c) Towing test and rotation arm test for tidal energy converter (adopted from Wang et al., 2022). (d) Tank test for the HWTEC (adopted from Park et al., 2022). (e) Pool test for the HWTEC (adopted from Chen et al., 2022; Jiang B. et al., 2020).

The pool test verifies that the output power of the HWTEC is increased by 24%–89% compared with a single wave energy converter, and the peak-to-average ratio of output voltage is decreased by 70% (Fig. 9(e)) (Chen et al., 2022; Jiang B. et al., 2020).

Currently, the artificial pool can simulate waves by the wave maker or simulate tides by the moveable beam, which is used widely in the test of single wave or tidal energy converter. A few wind-wave-tide pools have been utilized to test wind-wave hybrid energy conversion, but utilization in HWTEC is not found.

2.3.3. Ocean test

Ocean test is carried out in real ocean and relies on offshore platforms or ships, and cannot be artificially simulated. The input from the natural ocean is completely random, uncontrollable, and non-repeatable. Therefore, it is mostly used to test the performance and life of the wave or tidal energy converter in the late stage of studies and carried out with one or two of the other two tests as an auxiliary test. Therefore, it is reported in only a few studies with strong financial support or small scale (Fig. 10) (Gu et al., 2018; Kaufmann et al., 2019;

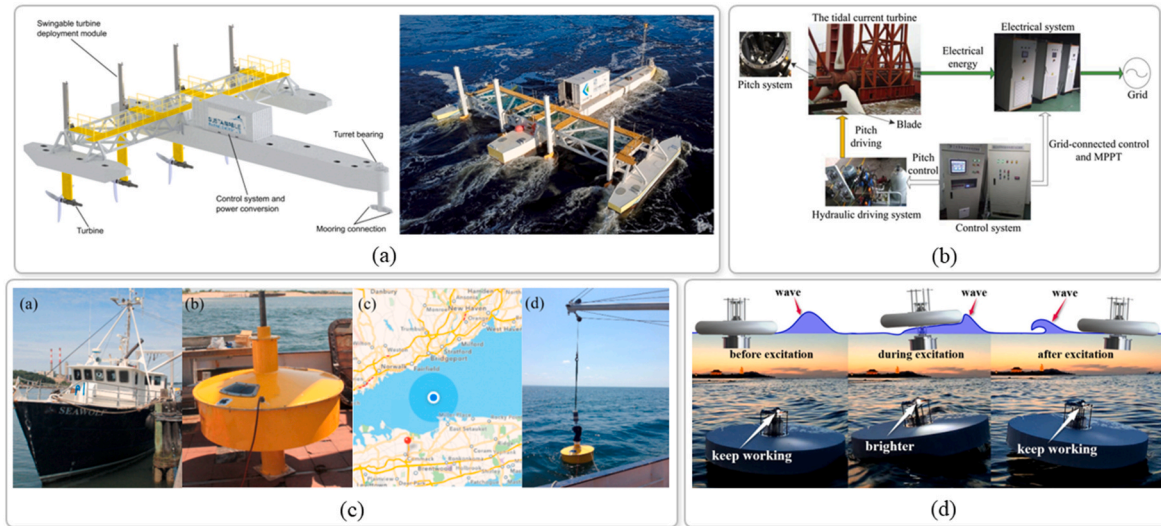

Fig. 10. Some reported ocean tests. (a) (adopted from Kaufmann et al., 2019). (b) (adopted from Gu et al., 2018). (c) (adopted from Liang et al., 2017). (d) (adopted from Yang et al., 2021).

Yang et al., 2021; Liang et al., 2017).

The energy converters show different performance in real ocean input, both in dynamic curve and efficiency. Large tidal energy converters in the form of power station are tested in (Kaufmann et al., 2019) (Fig. 10 (a)) and (Gu et al., 2018) (Fig. 10 (b)). The output power in (Gu et al., 2018) fluctuates between 0 to the rated power, and can reach 1/3 rated power in most working time. And the efficiency in ocean tests is calculated to be 18% lower than design value. The reduction of output power and efficiency occurs as well in the shipboard wave energy converter (Liang et al., 2017) and mobile wave energy converter (Yang et al., 2021). It is common that the performance of the wave or tidal energy converter in ocean tests has larger fluctuation than in dry lab tests and leads lower overall power and efficiency during ocean tests. The energy loss due to variable ocean conditions is difficult to predict in the time-domain modeling, and the coupling effect in HWTEC increase the complexity in continuity equation modeling, undoubtedly. Hence, the necessity of discretized modeling method in 2.2.2 is verified further. However, the shortcoming of ocean test is that the efficiency cannot be measured directly in real ocean.

Therefore, the ocean test is an indispensable link in the process of transition from academic research to engineering practice, even though the modeling, simulation, dry lab and pool test are developing rapidly.

2.3.4. Summary

The research on hybrid wave-tidal energy conversion technology is still in the exploratory stage, and few mature study has been verified, so the ocean test are not accessible. However, ocean test will be a good auxiliary test with dry lab test or pool test to test the performance of the HWTEC in real ocean conditions once these studies are accepted.

In summary, the test methods for single wave or tidal energy conversion can still be use in hybrid wave-tidal energy conversion technology. Current studies on hybrid wave-tidal energy conversion technology are still in early stage, so the dry lab test and the pool test are commonly used, but the ocean test is reported rarely. However, further improvement is necessary for the test of HWTEC due to the coupling of the wave and tide. For example, the improvement of the drive control is needed to obtain a better simulation of the coupling effect of wave and tidal inputs in dry lab tests; A pool that can simulate waves and tidal currents at the same time is needed in the pool test.

3. Conclusion

The current technical state of hybrid wave-tidal energy conversion is reviewed in this paper, including working principle, method of modeling, engineering design and method of test. Hybrid wave-tidal energy conversion has high feasibility, high potential and low cost compared to single wave or tidal energy conversion technology. Research gaps and future research directions are identified based on the literature review.

State of the Art:

1. In device designs and working principles, most current HWTEC are constructed by simply combing the wave energy converter and tidal energy converter together, without effectively utilizing the coupling between modules to enhance the efficiency and output power. Only a few studies have attempted to fully leverage the coupling effect between modules to further improve the output stability. While some cases verify that coupling effect can improve the overall performance, it is not always the case. Positive coupling should be verified and utilized, while negative coupling should be avoided through accurate modeling/simulation and proper evaluation system.
2. In modeling and simulation, the commonly used methods of dynamic modeling and hydro dynamic CFD finite element simulation derived from the study on single wave or tidal energy conversion. For HWTEC with strong coupling, non-linear system modeling offers better accuracy in revealing dynamic characteristics, albeit with increases complexity in solution. Due to assumption of the continuous input functions in most models, the prediction of motion under non-linear mechanism drifts away from real-life situations.
3. Currently dry lab tests and pool tests are the main methods for examining the performance of prototypes in the early stage of development. However, it is more challenging to build a test platform for HWTEC compared to a single wave or tidal energy converter. Only a handful wind-wave-tide pools have been established to support the research on multi-energy conversion.

Future Research Directions:

1. The single wave or tidal energy conversion, as the basic technology, still requires further development, especially in fundamental aspects such as stability, survivability, mooring method, etc.

- Regarding HWTEC, modeling approaches able to analyze the coupling effect between different modules are essential. It is crucial to develop a modeling approach with random input signals instead of continuous input functions, which also needs to encompass the non-linear dynamic response solution based on dynamic equations.
- The general equation of motion and the hydro dynamic finite element simulation are independent in terms of implementation. When they are used for HWTEC with strong coupling effects, co-simulation algorithms or a dedicated software environment that can integrate the results from both approaches.
- Besides, there is a gap in collaborative control and interactions between modules for HWTEC with coupling. It will be much more complex than single wave or tidal energy converter, and will be a great factor affecting the dynamic analysis and output performance of HWTEC.
- In tests, dry lab test is suitable and convenient to the precise performance testing for the HWTEC, and ocean test should be carried out with dry lab test or pool test, for the feasibility evaluation of the HWTEC in late stage. Further development and wider utilization of wind-wave-tide pools will support the research on HWTEC as well.
- Meanwhile, in order to prevent significant cost increases with minimal benefits, studies on project portfolio management and economic benefits are crucial as well. This includes assessing technical compatibilities, overall feasibility, and mutual benefits.

In summary, in the development of multi-ocean energy conversion technologies, it is crucial to analyze the potential and challenges in hybrid wave-tidal energy conversion technology. Multidisciplinary research teams will be required to develop novel HWTEC systems in the future applications.

CRedit authorship contribution statement

Peihao Chen: Writing – review & editing, Writing – original draft, Methodology, Investigation, Formal analysis, Data curation, Conceptualization. **Dawei Wu:** Writing – review & editing, Supervision, Resources, Project administration, Formal analysis.

Declaration of competing interest

The authors declare that they have no known competing financial interests or personal relationships that could have appeared to influence the work reported in this paper.

Data availability

No data was used for the research described in the article.

Acknowledgements

The authors are thankful for the financial support from the EPSRC (the Engineering and Physical Sciences Research Council) of the United Kingdom via the research project EP/X038823/1.

References

- Aderinto, T., Li, H., 2019. Review on power performance and efficiency of wave energy converters. *Energies* 12 (22), 4329. <https://doi.org/10.3390/en12224329>.
- Al Shami, E., Zhang, R., Wang, X., 2019. Point absorber wave energy harvesters: a review of recent developments. *Energies* 12 (1), 47. <https://doi.org/10.3390/en12010047>.
- ANSYS, 2013. ANSYS Fluent Theory Guide. Release 15.0. ANSYS, Canonsburg, PA, USA, p. 780p.
- Borba, E.M., Brito, R.M., 2017. An index assessing the energetic complementarity in time between more than two energy resources. *Energy Power Eng.* 9 (9) <https://doi.org/10.4236/epe.2017.99035>.
- Calheiros-Cabral, T., Clemente, D., Rosa-Santos, P., Taveira-Pinto, F., Ramos, V., Morais, T., Cestaro, H., 2020. Evaluation of the annual electricity production of a hybrid breakwater-integrated wave energy converter. *Energy* 213, 118845. <https://doi.org/10.1016/j.energy.2020.118845>.

- Cheng, Y., Dai, S., Dai, S., Ji, C., Collu, M., Yuan, Z., Incecik, A., 2022. Energy conversion and hydrodynamic analysis of multi-degree-of-freedom wave energy converters integrated into a semi-submersible platform. *Energy Convers. Manag.* 252, 115075 <https://doi.org/10.1016/j.enconman.2021.115075>.
- Chen, P., Yang, Y., 2023. Design, dynamics modeling, and experiments of a vibration energy harvester on bicycle. *IEEE ASME Trans. Mechatron.* 28 (5), 2670–2678. <https://doi.org/10.1109/TMECH.2023.3246516>.
- Chen, S., Jiang, B., Li, X., Huang, J., Wu, X., Xiong, Q., Parker, R.G., Zuo, L., 2022. Design, dynamic modeling and wave basin verification of a hybrid wave-current energy converter. *Appl. Energy* 321, 119320. <https://doi.org/10.1016/j.apenergy.2022.119320>.
- Chen, S., Jiang, B., Li, X., Xiong, Q., Huang, J., Zuo, L., 2019. Design and dynamics of hybrid wave and current energy converter. In: *Proceedings of the ASME Design Engineering Technical Conference* 8. <https://doi.org/10.1115/DETC2019-98040>.
- Chen, W., Lin, X., Lu, Y., Li, S., Wang, L., Zhang, Y., Gao, F., 2023. Design and experiment of a double-wing wave energy converter. *Renew. Energy* 202, 1497–1506. <https://doi.org/10.1016/j.renene.2022.12.033>.
- Clemente, D., Rosa-Santos, P., Taveira-Pinto, F., 2021. On the potential synergies and applications of wave energy converters: a review. *Renew. Sustain. Energy Rev.* 135, 110162 <https://doi.org/10.1016/j.rser.2020.110162>.
- Dai, Y., Chen, Y., Xie, L., 2017. A study on a novel two-body floating wave energy converter. *Ocean Eng.* 130, 407–416. <https://doi.org/10.1016/j.oceaneng.2016.11.049>.
- Du, X., Du, L., Cai, X., Hao, Z., Xie, X., Wu, F., 2022a. Dielectric elastomer wave energy harvester with self-bias voltage of an ancillary wind generator to power for intelligent buoys. *Energy Convers. Manag.* 253, 115178 <https://doi.org/10.1016/j.enconman.2021.115178>.
- Du, X., Wang, Y., Chen, H., Li, C., Han, Y., Yurchenko, D., Wang, J., Yu, H., 2022b. Vortex-induced piezoelectric cantilever beam vibration for ocean wave energy harvesting via airflow from the orifice of oscillation water column chamber. *Nano Energy* 104, 107870. <https://doi.org/10.1016/j.nanoen.2022.107870>.
- Du, X., Zhang, M., Kang, H., Chang, H., Yu, H., 2021. Theoretical study on a novel piezoelectric ocean wave energy harvester driven by oscillating water column. *Energy Sources, Part A Recovery, Util. Environ. Eff.* 1–21. <https://doi.org/10.1080/15567036.2020.1862367>.
- Falcão, A.F.O., 2010. Wave energy utilization: a review of the technologies. *Renew. Sustain. Energy Rev.* 14 (3), 899–918. <https://doi.org/10.1016/j.rser.2009.11.003>.
- Falcão, A.F.O., Henriques, J.C.C., 2016. Oscillating-water-column wave energy converters and air turbines: a review. *Renew. Energy* 85, 1391–1424. <https://doi.org/10.1016/j.renene.2015.07.086>.
- Fang, H., Wei, Y., Feng, Y., 2020. Investigation of a double-degree-of-freedom wave energy converter. *Energy Rep.* 6, 402–406. <https://doi.org/10.1016/j.egyr.2020.11.223>.
- Fang, Z., Wang, J., Xiong, F., Xie, X., 2021. Research on the dynamic characteristics of the acquisition mechanism of the oscillating flapping wing wave energy power generation device based on the bond graph. *J. Phys. Conf.* 2125 (1), 012050 <https://doi.org/10.1088/1742-6596/2125/1/012050>.
- Fang, Z., Yang, Y., Zuo, X., He, K., Yang, W., 2023. Modelling and simulation of two-float oscillating flapping-wing wave energy converter. *J. Phys. Conf.* 2442 (1), 012031 <https://doi.org/10.1088/1742-6596/2442/1/012031>.
- Gao, H., Yu, Y., 2018. The dynamics and power absorption of cone-cylinder wave energy converters with three degree of freedom in irregular waves. *Energy* 143, 833–845. <https://doi.org/10.1016/j.energy.2017.11.036>.
- Gomes, R.P.F., Lopes, M.F.P., Henriques, J.C.C., Gato, L.M.C., Falcão, A.F.O., 2015. The dynamics and power extraction of bottom-hinged plate wave energy converters in regular and irregular waves. *Ocean Eng.* 96, 86–99. <https://doi.org/10.1016/j.oceaneng.2014.12.024>.
- Gu, Y.-j., Liu, H.-w., Li, W., Lin, Y.-g., Li, Y.-j., 2018. Integrated design and implementation of 120-kW horizontal-axis tidal current energy conversion system. *Ocean Eng.* 158, 338–349. <https://doi.org/10.1016/j.oceaneng.2018.04.017>.
- Henriques, J.C.C., Lopes, M.F.P., Lopes, M.C., Gato, L.M.C., Dente, A., 2011. Design and testing of a non-linear power take-off simulator for a bottom-hinged plate wave energy converter. *Ocean Eng.* 38 (11), 1331–1337. <https://doi.org/10.1016/j.oceaneng.2011.06.003>.
- Hu, H., Xue, W., Jiang, P., Li, Y., 2022. Bibliometric analysis for ocean renewable energy: an comprehensive review for hotspots, frontiers, and emerging trends. *Renew. Sustain. Energy Rev.* 167, 112739 <https://doi.org/10.1016/j.rser.2022.112739>.
- Jiang, B., Li, X., Chen, S., Xiong, Q., Chen, B., Parker, R.G., Zuo, L., 2019. Dynamics of a hybrid wave-current energy converter with a novel power take-off mechanism. In: *Proceedings of SPIE - the International Society for Optical Engineering*, vol. 10967, 109670U. <https://doi.org/10.1117/12.2514186>.
- Jiang, B., Li, X., Chen, S., Xiong, Q., Chen, B., Parker, R.G., Zuo, L., 2020. Performance analysis and tank test validation of a hybrid ocean wave-current energy converter with a single power takeoff. *Energy Convers. Manag.* 224, 113268 <https://doi.org/10.1016/j.enconman.2020.113268>.
- Jiang, C., Cao, F., Wang, Q., Shi, H., 2023. Analysis method of WEC sub-system for hybrid wind-wave energy system based on reconstructed displacements. *Ocean Eng.* 278, 114268 <https://doi.org/10.1016/j.oceaneng.2023.114268>.
- Kaufmann, N., Carolus, T., Starzmann, R., 2019. Turbines for modular tidal current energy converters. *Renew. Energy* 142, 451–460. <https://doi.org/10.1016/j.renene.2019.04.120>.
- Khan, N., Kalair, A., Abas, N., Haider, A., 2017. Review of ocean tidal, wave and thermal energy technologies. *Renew. Sustain. Energy Rev.* 72, 590–604. <https://doi.org/10.1016/j.rser.2017.01.079>.
- Lewis, M., McNaughton, J., Márquez-Dominguez, C., Todeschini, G., Togneri, M., Masters, L., Allmark, M., Stallard, T., Neill, S., Goward-Brown, A., Robins, P., 2019.

- Power variability of tidal-stream energy and implications for electricity supply. *Energy* 183, 1061–1074. <https://doi.org/10.1016/j.energy.2019.06.181>.
- Lewis, M., Neill, S.P., Robins, P.E., Hashemi, M.R., 2015. Resource assessment for future generations of tidal-stream energy arrays. *Energy* 83, 403–415. <https://doi.org/10.1016/j.energy.2015.02.038>.
- Liang, C., Ai, J., Zuo, L., 2017. Design, fabrication, simulation and testing of an ocean wave energy converter with mechanical motion rectifier. *Ocean Eng.* 136, 190–200. <https://doi.org/10.1016/j.oceaneng.2017.03.024>.
- Li, Q., Li, X., Mi, J., Jiang, B., Chen, S., Zuo, L., 2021. Tunable wave energy converter using variable inertia flywheel. *IEEE Trans. Sustain. Energy* 12 (2), 1265–1274. <https://doi.org/10.1109/TSTE.2020.3041664>.
- Liu, Y., Xu, L., Zuo, L., 2017. Design, modeling, lab, and field tests of a mechanical-motion-rectifier-based energy harvester using a ball-screw mechanism. *IEEE ASME Trans. Mechatron.* 22 (5), 1933–1943. <https://doi.org/10.1109/TMECH.2017.2700485>.
- Li, X., Chen, C.-A., Chen, S., Xiong, Q., Huang, J., Lambert, S., Keller, J., Parker, R.G., Zuo, L., 2022. Dynamic characterization and performance evaluation of a 10-kW power take-off with mechanical motion rectifier for wave energy conversion. *Ocean Eng.* 250, 110983 <https://doi.org/10.1016/j.oceaneng.2022.110983>.
- Li, X., Chen, C., Li, Q., Xu, L., Liang, C., Ngo, K., Parker, R.G., Zuo, L., 2020. A compact mechanical power take-off for wave energy converters: design, analysis, and test verification. *Appl. Energy* 278, 115459. <https://doi.org/10.1016/j.apenergy.2020.115459>.
- Martin, D., Li, X., Chen, C.-A., Thiagarajan, K., Ngo, K., Parker, R., Zuo, L., 2020. Numerical analysis and wave tank validation on the optimal design of a two-body wave energy converter. *Renew. Energy* 145, 632–641. <https://doi.org/10.1016/j.renene.2019.05.109>.
- Meinert, P., Gillin, L., Kofoid, J.P., 2008. User manual for WOPSim: wave overtopping power simulation. In: *Hydraulics and Coastal Engineering*, vol. 44. Aalborg University, Aalborg, Denmark.
- Neill, S.P., Hashemi, M.R., Lewis, M.J., 2014. Optimal phasing of the European tidal stream resource using the greedy algorithm with penalty function. *Energy* 73, 997–1006. <https://doi.org/10.1016/j.energy.2014.07.002>.
- Nico, V., Frizzell, R., Punch, J., 2020. The identification of period doubling in a non-linear two-degree-of-freedom electromagnetic vibrational energy harvester. *IEEE ASME Trans. Mechatron.* 25 (6), 2973–2980. <https://doi.org/10.1109/TMECH.2020.3000431>.
- Pan, Q., Wang, B., Zhang, L., Li, Z., Yang, Z., 2022. Whisk-inspired motion converter for ocean wave energy harvesting. *IEEE ASME Trans. Mechatron.* 27 (3), 1808–1811. <https://doi.org/10.1109/TMECH.2021.3093939>.
- Park, M.-S., Lee, S.-H., Ko, S.-C., 2022. Experimental capture width ratio on unit module system of hybrid wave energy converter for nearshore. *Appl. Sci.* 12 (12), 5845. <https://doi.org/10.3390/app12125845>.
- Peng, Z., Zhu, Q., 2009. Energy harvesting through flow-induced oscillations of a foil. *Phys. Fluids* 21 (12), 123602. <https://doi.org/10.1063/1.3275852>.
- Ramli, M.A., Mustapa, M.A., Rozali, R.H., Azrulhisham, E.A., 2022. Hydrodynamic performance of heaving motion on cylinder and conical two-body point absorber in low wave energy. *IOP Conf. Ser. Earth Environ. Sci.* 1046 (1), 012010 <https://doi.org/10.1088/1755-1315/1046/1/012010>.
- Reikard, G., 2013. Integrating wave energy into the power grid: simulation and forecasting. *Ocean Eng.* 73, 168–178. <https://doi.org/10.1016/j.oceaneng.2013.08.005>.
- Roy, A., Auger, F., Dupriez-Robin, F., Bourguet, S., Tran, Q.T., 2018. Electrical power supply of remote maritime areas: a review of hybrid systems based on marine renewable energies. *Energies* 11 (7), 1904. <https://doi.org/10.3390/en11071904>.
- Shetty, C., Priyam, A., 2022. A review on tidal energy technologies. *Mater. Today: Proc.* 56, 2774–2779. <https://doi.org/10.1016/j.matpr.2021.10.020>.
- Silva, R.N., Nunes, M.M., Oliveira, F.L., Oliveira, T.F., Brasil, A.C.P., Pinto, M.S.S., 2023. Dynamical analysis of a novel hybrid oceanic tidal-wave energy converter system. *Energy* 263, 125933. <https://doi.org/10.1016/j.energy.2022.125933>.
- Sinha, A., Mendonça, P., Belga, F., Cestaro, H., Morais, T., Clemente, D., Cabral, T., Taveira-Pinto, F., Rosa-Santos, P., Lopes, H., 2019. Preliminary design of a hybrid wave energy converter integrated into a rubble mound breakwater. In: *Proceedings of the European Wave and Tidal Energy Conference*, pp. 1–6. Naples, Italy. <https://www.researchgate.net/publication/338740936>.
- Si, Y., Liu, X., Wang, T., Feng, B., Qian, P., Ma, Y., Zhang, D., 2022. State-of-the-art review and future trends of development of tidal current energy converters in China. *Renew. Sustain. Energy Rev.* 167, 112720 <https://doi.org/10.1016/j.rser.2022.112720>.
- Wang, P., Zhao, B., Cheng, H., Huang, B., He, W., Zhang, Q., Zhu, F., 2022. Study on the performance of a 300W counter-rotating type horizontal axis tidal turbine. *Ocean Eng.* 255, 111446 <https://doi.org/10.1016/j.oceaneng.2022.111446>.
- Westwood, A., 2004. Ocean power: wave and tidal energy review. *Refocus* 5 (5), 50–55. [https://doi.org/10.1016/S1471-0846\(04\)00226-4](https://doi.org/10.1016/S1471-0846(04)00226-4).
- Westwood, A., 2007. Wave and tidal – project review. *Renewable Energy Focus* 8 (4), 30–33. [https://doi.org/10.1016/S1471-0846\(07\)70103-8](https://doi.org/10.1016/S1471-0846(07)70103-8).
- Widén, J., Carpmann, N., Castellucci, V., Lingfors, D., Olauson, J., Remouit, F., Bergkvist, M., Grabbe, M., Waters, R., 2015. Variability assessment and forecasting of renewables: a review for solar, wind, wave and tidal resources. *Renew. Sustain. Energy Rev.* 44, 356–375. <https://doi.org/10.1016/j.rser.2014.12.019>.
- Wu, B., Zhan, M., Wu, R., Zhang, X., 2023. The investigation of a coaxial twin-counter-rotating turbine with variable-pitch adaptive blades. *Energy* 267, 126546. <https://doi.org/10.1016/j.energy.2022.126546>.
- Xie, L., Cai, S., Huang, G., Huang, L., Li, J., Li, X., 2020a. On energy harvesting from a vehicle damper. *IEEE ASME Trans. Mechatron.* 25 (1), 108–117. <https://doi.org/10.1109/TMECH.2019.2950952>.
- Xie, Q., Zhang, T., Pan, Y., Zhang, Z., Yuan, Y., Liu, Y., 2020b. A novel oscillating buoy wave energy harvester based on a spatial double X-shaped mechanism for self-powered sensors in sea-crossing bridges. *Energy Convers. Manag.* 204, 112286 <https://doi.org/10.1016/j.enconman.2019.112286>.
- Xie, Y., Lu, K., Zhang, D., 2014. Investigation on energy extraction performance of an oscillating foil with modified flapping motion. *Renew. Energy* 63, 550–557. <https://doi.org/10.1016/j.renene.2013.10.029>.
- Yang, Y., Chen, P., Liu, Q., 2021. A wave energy harvester based on coaxial mechanical motion rectifier and variable inertia flywheel. *Appl. Energy* 302, 117528. <https://doi.org/10.1016/j.apenergy.2021.117528>.
- Yang, Y., Pian, Y., Liu, Q., 2019. Design of energy harvester using rotating motion rectifier and its application on bicycle. *Energy* 179, 222–231. <https://doi.org/10.1016/j.energy.2019.05.036>.
- Yin, X., Zhao, X., Zhang, W., 2018. A novel hydro-kite like energy converter for harnessing both ocean wave and current energy. *Energy* 158, 1204–1212. <https://doi.org/10.1016/j.energy.2018.03.121>.
- Zhang, Y., Zhao, Y., Sun, W., Li, J., 2021. Ocean wave energy converters: technical principle, device realization, and performance evaluation. *Renew. Sustain. Energy Rev.* 141, 110764 <https://doi.org/10.1016/j.rser.2021.110764>.
- Zhang, Z., Zhang, X., Chen, W., Rasim, Y., Salman, W., Pan, H., Yuan, Y., Wang, C., 2016. A high-efficiency energy regenerative shock absorber using supercapacitors for renewable energy applications in range extended electric vehicle. *Appl. Energy* 178, 177–188. <https://doi.org/10.1016/j.apenergy.2016.06.054>.
- Zhao, T., Xu, M., Xiao, X., Ma, Y., Li, Z., Wang, Z.L., 2021. Recent progress in blue energy harvesting for powering distributed sensors in ocean. *Nano Energy* 88, 106199. <https://doi.org/10.1016/j.nanoen.2021.106199>.
- Zheng, S., Zhang, Y., Iglesias, G., 2020. Power capture performance of hybrid wave farms combining different wave energy conversion technologies: the H-factor. *Energy* 204, 117920. <https://doi.org/10.1016/j.energy.2020.117920>.
- Zhu, Q., Peng, Z., 2009. Mode coupling and flow energy harvesting by a flapping foil. *Phys. Fluids* 21 (3), 033601. <https://doi.org/10.1063/1.3092484>.
- Zhu, Q., 2011. Optimal frequency for flow energy harvesting of a flapping foil. *J. Fluid Mech.* 675, 495–517. <https://doi.org/10.1017/S0022112011000334>.