

Aligned Carbon Nanotube Reinforcement of Aerospace Carbon Fiber Composites: Substructural Strength Evaluation for Aerostructure Applications

R. Guzmán de Villoria¹

Massachusetts Institute of Technology, Cambridge, MA, 02139

L. Ydrefors², P. Hallander³

Saab AB, SE-581 88 Linköping, Sweden

K. Ishiguro⁴

Massachusetts Institute of Technology, Cambridge, MA, 02139

P. Nordin⁵

Saab AB, SE-581 88 Linköping, Sweden

and

B. L. Wardle⁶

Massachusetts Institute of Technology, Cambridge, MA, 02139

Vertically aligned carbon nanotubes (VACNTs) are placed between all plies in an aerospace carbon fiber reinforced plastic laminate (unidirectional plies, [(0/90/±45)₂]_s) to reinforce the interlaminar region in the z-direction. Significant improvement in Mode I and II interlaminar toughness have been observed previously. In this work, several substructural in-plane strength tests relevant to aerostructures were undertaken: bolt/tension-bearing, open hole compression, and L-shape laminate bending. Improvements are observed for the nanostitched samples: critical bearing strength by 30%, open-hole compression ultimate strength by 10%, and L-shape laminate energy (via increased deflection) of 40%. The mechanism of reinforcement is not compliant interlayer creation, but rather is a fiber-stitching mechanism, as no increase in interlayer thickness occurs with the nanostitches. Unlike traditional (large-fiber/tow/pin) stitching or z-pinning techniques that damage in-plane fibers and reduce laminate in-plane strengths, the nano-scale CNT-based ‘stitches’ improve in-plane strength, demonstrating the potential of such an architecture for aerospace structural applications. The quality of VACNT transfer to the prepreg laminates has not been optimized and therefore the noted enhancement to strength may be considered conservative. Ongoing work has been undertaken to both improve VACNT transfer and expand the data set.

Nomenclature

AE = Acoustic Emission
CNTs = Carbon Nanotubes

¹ Postdoctoral Associate, Department of Aeronautics and Astronautics. Currently Researcher at IMDEA – Materials Institute, C/Professor Arunguren, s/n, 28040, Madrid, Spain. AIAA Member.

² Materials and Process Engineer. Currently Exova, SE-581 88 Linköping, Sweden.

³ Senior Materials and Process Engineer, Composites and Bonding.

⁴ Visiting PhD Student, Department of Aeronautics and Astronautics. Currently Boeing (Japan). AIAA Member.

⁵ Technical Fellow, Overall Design and Survivability Systems Integration, Business Area Aeronautics.

⁶ Associate Professor, Department of Aeronautics and Astronautics. AIAA Associate Fellow.

<i>CVD</i>	=	Chemical Vapor Deposition
<i>OHC</i>	=	Open Hole Compression
<i>P</i>	=	Load in L-shaped Bend Test
<i>VACNT</i>	=	Vertically Aligned Carbon Nanotube
Δ	=	Deflection at Failure of a L-Shape Laminate in Bending

I. Introduction

A critical limitation of advanced composites materials is their z-direction properties, particularly mechanical properties in the region between laminated plies. Several technologies have been developed to reinforce the composite in the through-thickness direction and reinforce the interface, including Z-pinning, stitching, and 3D weaving. However, these solutions use micron-diameter fibers in mm-scale assemblies, which reduces the in-plane mechanical properties due to in-plane fiber volume loss and causes lamina fiber damage during the stitching process¹⁻⁴. Carbon nanotubes (CNTs) are envisioned as a second fiber reinforcement that can be applied at ply interfaces without reducing the in-plane properties. In past work, vertically aligned carbon nanotubes (VACNTs) placed at the interface (so-termed ‘nanostitching’⁵) of prepreg plies can improve the critical energy release rate 2.5X in Mode I over the baseline composites. This improvement is greater than the results reported for standard z-pinning reinforcement^{2,5,13}. Apart from interlaminar toughness, there are other mechanical properties than can benefit from interlaminar reinforcement. Bolt-bearing and open-hole compression failure mechanisms can be caused by interlaminar delamination, fiber microbuckling, etc^{1,6}. Complex shapes, including L-shape cured laminates (which is a typical element in aerospace structural components such as angle brackets, co-cured webs, or frames [7]) usually fail by interlaminar delamination via a tensile interlaminar mode. Nanostitched interfaces, made by placing VACNTs between plies in the laminate, should improve these mechanical properties by reinforcing the composite in the through-thickness direction without modifying the in-plane mechanical contributions of the lamina/plies. A first experimental study of these mechanical improvements is presented here. In such laminate engineering strength tests, the three-dimensional and highly mode-coupled nature of laminate failure is highlighted.

II. Experimental

Fabrication of the specimens, including VACNT synthesis, VACNTs transplantation process and laminate fabrication is first presented. Characterization of the specimens and then testing by bolt bearing, open hole compression, and L-shape laminate strength tests are then described.

A. Sample Fabrication

VACNTs were grown in a standard tube furnace (Lindberg/BlueM) by chemical vapor deposition (CVD) at atmospheric pressure. Large area (20 cm x50 cm) silicon wafers coated with catalyst by e-beam evaporation (1 nm Fe / 10 nm Al₂O₃) were placed in the quartz tube (44 mm inner diameter) reactor, positioned inside the furnace. The substrate is pretreated at 650°C during 7 minutes in a reducing atmosphere (H₂/He) to condition the catalyst. A reactant mixture (H₂/He/C₂H₄) is introduced afterwards to grow VACNTs. Further details of the process can be found elsewhere^{5,8}. VACNT length is controlled by varying the growth time. For interlaminar nanostitches, the VACNTs length used is ~20 μm to avoid introducing additional thickness to the ply interlayer⁵, which corresponds to a 0.5 min growth time (Fig.1).

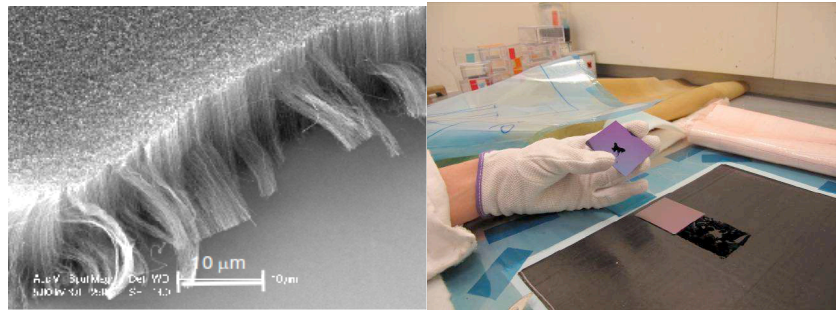

Figure 1. VACNTs used to nanostitch the carbon fiber prepreg unidirectional plies. Scanning electron micrograph of VACNTs (left) and typical (incomplete) transfer of VACNT to the surface of prepreg from Si growth substrate (in hand) (right).

The VACNT forest was placed on the prepreg surface by transplantation. A unidirectional aerospace carbon prepreg tape (Hexcel AS4/8552) was used for all laminates in the study, and various techniques were explored to successfully transfer VACNTs to the prepreg by making use of the tackiness of the prepreg material for adhesive transfer from the Si growth substrate. An optimal process for repeatable transfer of VACNTs was established, but

due to limited quantities of nanostitch available in the initial project timeframe, many of the VACNT transfers used were not optimal. A typical transfer is shown in Fig. 1 right where it can be seen that only partial transfer of the VACNTs to the prepreg was achieved. Therefore, the results of reinforcement may be considered as conservative (see later discussion). Ongoing work is aimed at repeating many of these experiments using optimally-transferred VACNTs. The laminate stacking sequence for all tests is $[(0/90/\pm 45)_2]_s$ with 15 nano-stitched interfaces in the same region of the laminate. These regions are detailed for each test type in the subsequent sections. The nominal nano-stitched thickness before curing was $20\ \mu\text{m}$. The laminates were assembled with the appropriate cure materials and cured in an autoclave following the manufacturer's recommendations (100 psig of total pressure at $5\ ^\circ\text{F}/\text{min}$ to $335\ ^\circ\text{F}$, hold for 2.5h, cool at $5\ ^\circ\text{F}/\text{min}$ to $140\ ^\circ\text{F}$ and vent pressure, let cool to room temperature). Once the laminates were cured, samples were trimmed and prepared for each test described below. Baselines/reference laminates without nanostitching were extracted from the same cured laminate. All of the samples, baseline and nanostitch specimens, had the same thickness after curing ($2.1\ \text{mm}$).

B. Bolt Bearing Test

A $210 \times 300\ \text{mm}^2$ laminate was cured in the autoclave. Baseline and nanostitched specimens of $171 \pm 2\ \text{mm} \times 36 \pm 0.6$ were trimmed from a single laminate. A $5.6\ \text{mm}$ diameter hole was machined into the nanostitched region as shown in Figure 2. A double-lap joining configuration was adopted, and the bolt fastener was attached to the carbon fiber specimen between two steel plates (Fig 2).

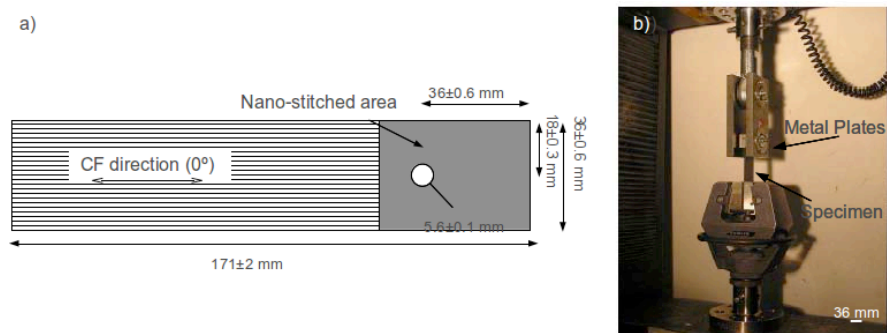

Figure 2. Bolt bearing specimen scheme. The grey region indicates the nanostitched region (a). Mechanical test set-up (b).

C. Open Hole Compression Test

A $210 \times 270\ \text{mm}^2$ laminate was cured in the autoclave. Baseline and nanostitched specimens of $220 \pm 2\ \text{mm} \times 24.0 \pm 0.5$ were trimmed from a single laminate. The test specimen is similar to that used in a standard tensile test but with a centrally located hole ($5.6\ \text{mm}$ diameter) machined into the nanostitched region ($25 \times 25\ \text{mm}^2$) as indicated in Figure 3. The laminates was placed between two holed ($20\ \text{mm}$ diameter) flat platens to prevent buckling and loaded in compression as indicated in Figure 3. An acoustic emission (AE) sensor was placed on one of the metal plates close to the nanostitched area in order to monitor damage events during the test.

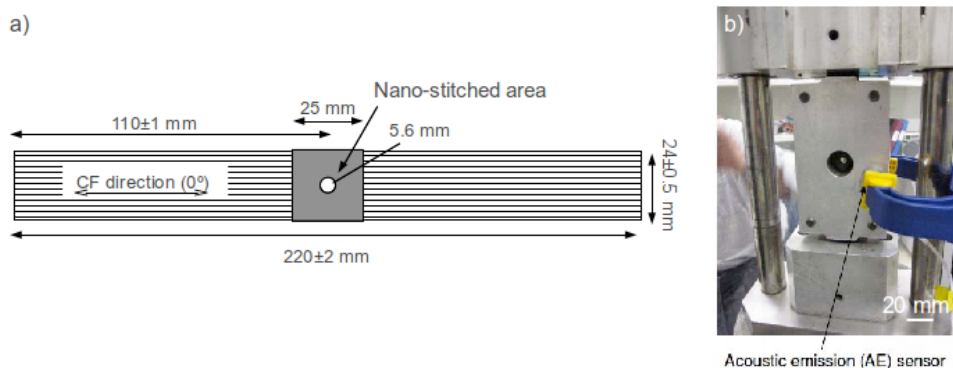

Figure 3. Open hole compression specimen set-up. The grey region indicates the nanostitched area (a). Test set-up showing the position of the acoustic emission sensor (b).

D. L-shape Laminate Bending Strength Test

Two L-shaped laminates of $220 \times 200 \text{ mm}^2$ were bent 90 degrees (7 mm of radius of curvature) prior to curing. Specimens were trimmed from these laminates to a 20 mm width. For the nanostitched specimens, the CNT region ($50 \times 20 \text{ mm}^2$) was centered on the bent section (see Fig 4). One side of the specimen was clamped and a force was applied to the free side of the specimen until the specimen failed. Details of the test set up are indicated in Figure 4.

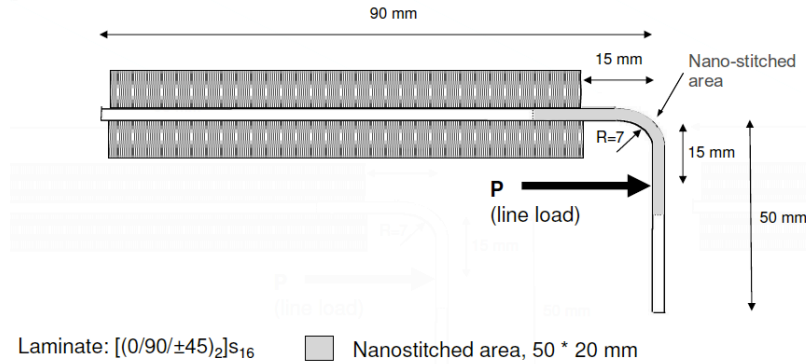

Figure 4. L-shape laminated specimen scheme. One side of the specimen (white) is clamped (pattern) on one side and a force is applied (P) to the L as shown.

III. Results and Discussion

After mechanical testing, specimens are inspected visually and by electron microscopy to evaluate the effects of the carbon nanotubes. A significant finding is that although $20 \mu\text{m}$ thick VACNT forests are added to each interface (typically 15 interfaces in a 16-ply laminate), the overall thickness of the cured nanostitched laminates is the same as the baselines. Thus, VACNTs are interpenetrating the adjacent plies and not creating an increased-thickness interlayer compared to the baseline laminates. SEM reveals CNTs at the interface and the creation of an interlaminar region that is no greater in thickness than the baseline laminates.

A. Bolt-bearing Testing

By comparing reference and nanostitched laminates, a different behavior is observed. For the baseline laminates, a clear initiation behavior is detected as a drop in the load displacement curve (see Fig. 5 left), however, VACNTs suppress this initial (onset) observable hole damage in the nanostitched laminates as can be seen in the exemplary curves in Figure 5. This reinforcement effect is related to the reinforced effect of the CNTs in the through-thickness direction, as has been reported previously for fuzzy-fiber nano-engineered composites¹. As expected for the CNTs orientation, the ultimate bolt-bearing strength was not affected by the interlaminar CNTs. However, because the onset of damage is suppressed, the useful strength (design value) of these laminates (critical offset bearing strength [9]) is increased by at least 30%. The results in Figure 5 are consistent (particularly suppression of the observable drop in load as in Fig. 5). Further work is being done to assess the nature of damage around the load-drop point

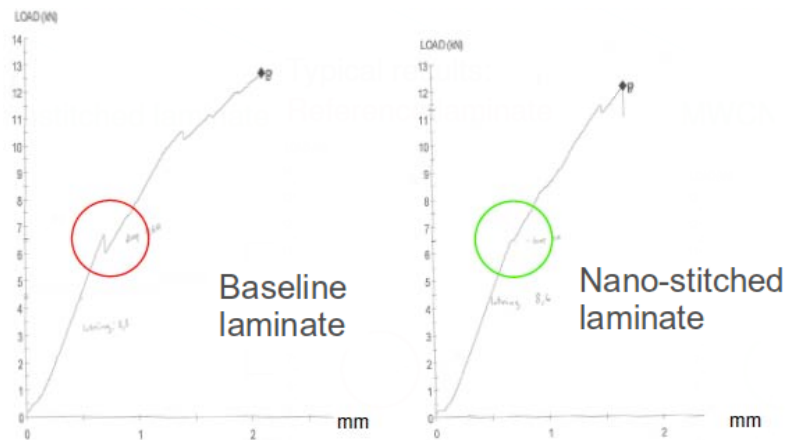

Figure 5. Exemplary load-displacement curves for the bolt-bearing tensile test. The initial (onset) hole damage is suppressed by the interlaminar CNTs.

indicated in Fig. 5 left (and observed for other baseline specimens) relative to the suppression of this feature in the nanostitched samples.

B. Open Hole Compression Testing

Five baseline and three nanostitched specimens were tested. Ultimate strength of these laminates shows an average increase of 10% which is attributed to the interlaminar CNT reinforcement, particularly delamination resistance which is critical in such a test due to propagation of delaminations at ply interfaces in combined modes including sublaminates buckling. Analysis of the data from the acoustic sensor reveals that for the baseline samples, acoustic events appear at lower loads than in the nanostitched samples. However, once a threshold load is reached, the number of acoustic events produced in the nanostitched sample is remarkably higher than in the baseline sample (Fig. 6). This might indicate a reinforcement effect of the CNTs in that damage is distributed more broadly in a microcracking mode rather than concentrating in a large (but fewer) delamination acoustic events, however, a deeper analysis is needed to substantiate this hypothesis.

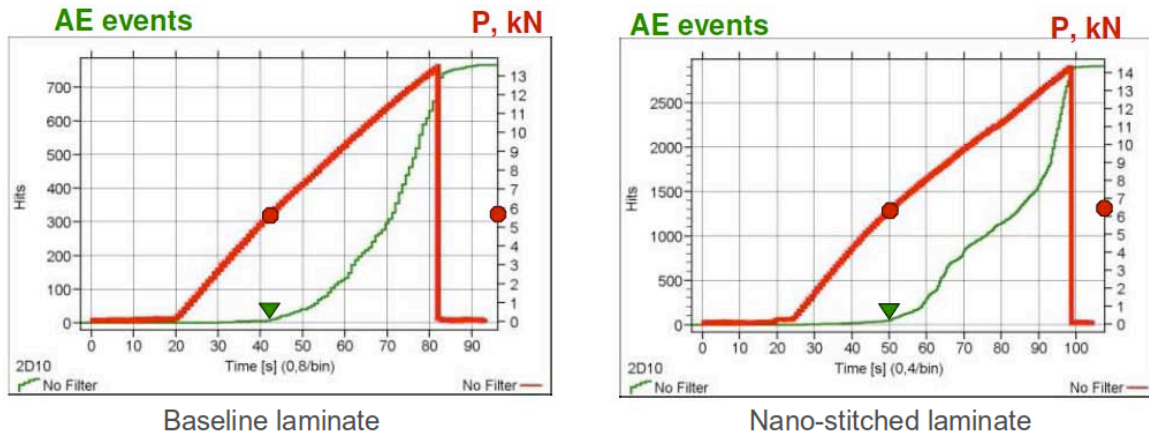
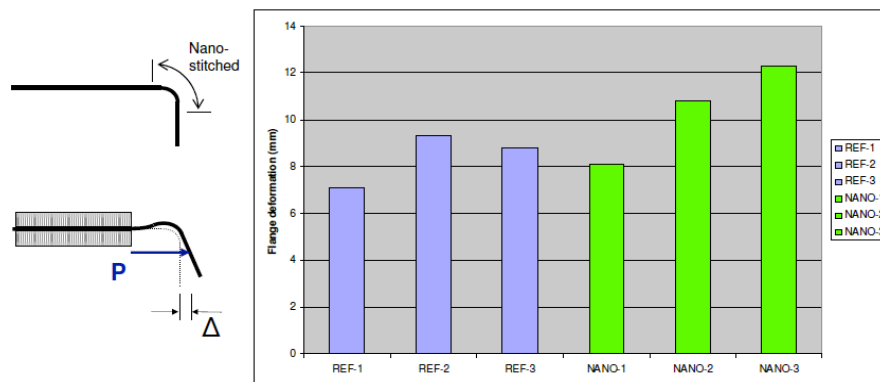

Figure 6. Exemplary loading curves from open hole compression testing (red) and the acoustic emission (AE) events (green) produced during the test for baseline (left) and the nanostitched samples (right). Note the different AE hits scale.

C. L-shape Laminate Bending Strength

The specimen with CNTs is tested in the nanostitched region, which is shaped as an L. Both laminates, reference/baseline and nanostitched, have the same thickness and quality in the L region, and both failed at the same load during the test (~450 N). The VACNTs seem to suppress critical pre-failure modes, increasing the deflection at failure of the nano-stitched samples by 20% relative to the reference samples (see Fig. 7) and requiring 40% more



Baseline: $\bar{\Delta} = 8,4 \text{ mm}$ Nano-stitched: $\bar{\Delta} = 10,4 \text{ mm}$

Figure 7. Deflection at failure (Δ) of L-shape laminated bending strength test. Baseline/REF (blue) and nanostitched samples (green). $\bar{\Delta}$ indicates the average deflection at failure.

energy to break the samples. Ongoing finite element analyses will be used to quantify the magnitude of increased stresses (interlaminar tension and shear are of primary interest¹⁰) sustained by the nanostitched specimens prior to laminate ultimate failure. Analysis of the L-region of a nanostitched sample reveals aligned CNTs that were pulled out from the interfaces of the micro-cracks producing during the test. Although the VACNTs are around 20 μm length, only 2-3 μm are pulled out from the resin. It is not possible to assess the failure mode of the CNTs, *i.e.*, pull-out, mixed mode, etc. via the SEM inspection. Similar behavior has been observed for Mode I tests of nanostitched samples⁵ and fuzzy-fiber composites¹.

IV. Conclusions and Recommendations

In this study, nanoengineered advanced aerospace-grade carbon fiber-epoxy composite laminates were fabricated by placing z-direction VACNTs across the interface of each ply. Several tests were performed in order to evaluate the effect of VACNTs on the complex failure of these substructural laminate strength tests, including damage initiation and ultimate failure of the laminated structures. A change in laminated behavior has been observed when VACNTs are added between the carbon fiber plies. VACNTs bridge the different plies improving the interlaminar properties and arresting some pre-failure modes, without creating an increased interlayer thickness, nor causing changes in the load-carrying capability of the in-plane carbon fibers. A decrease in load-carrying capability is typically observed due to damage from traditional stitching and z-pinning approaches. In all the tests done in this study, the nanostitched composites showed better performance than the baseline samples. Microscopy analysis of the interfaces showed CNTs partially pulled-out from the matrix. However a deeper analysis is needed in order to understand the reinforcement and failure mechanisms of this new generation of nanoengineered composites in more detail. VACNTs are a promising reinforcement that improves the interlaminar properties of the laminates as shown in this work, leading to enhanced substructural laminate strength, and also adding new potential multi-functionality (such as damage sensing)^{11,12}. Ongoing work seeks to expand the data set presented here, increase the quality of transferred nanostitches, and more deeply understand the damage suppression modes from the nanostitches I the different tests.

Acknowledgments

This work was supported by Boeing, EADS, Embraer, Lockheed Martin, Saab AB, Composite Systems Technology, Hexcel, and TohoTenax through MIT's Nano-Engineered Composite aerospace Structures (NECST) Consortium. The authors thank Sunny Wicks (MIT), John Kane (MIT) and the entire necslab at MIT for technical support and advice. This work made use of the Shared Experimental Facilities supported in part by the MRSEC Program of the National Science Foundation under award number DMR-0819762. This work made use of experimental facilities from the Institute of Soldier Nanotechnologies at MIT (ISN) and was carried out in part through the use of MIT's Microsystems Technology Laboratories.

References

1. Wicks, S., Guzman de Villoria, R. and Wardle, B.L. "Interlaminar and Intralaminar Reinforcement of Composite Laminates with Aligned Carbon Nanotubes". *Composite Science and Technology*, Vol. 70, 2010, pp. 20-28.
2. Tong, L., Mouritz, A.P. and M.K., B. "3D Fibre Reinforced Polymer Composites", Oxford, 2002.
3. Dransfield, K.A., Jain, L.K. and Mai, Y.-W. "On the effects of stitching in CFRPs--I. mode I delamination toughness", *Composites Science and Technology*, Vol. 58, 1998, pp. 815-827.
4. Mouritz, A.P., Leong, K.H. and Herszberg, I. "A review of the effect of stitching on the in-plane mechanical properties of fibre-reinforced polymer composites", *Composites Part A: Applied Science and Manufacturing*, Vol. 28, 1997, pp. 979-991.
5. Garcia, E.J., Wardle, B.L. and Hart, A.J. "Joining Prepreg Composite Interfaces with Aligned Carbon Nanotubes", *Composites Part A*, Vol. 39, 2008, pp. 1065-1070.
6. Suemasu, H., Takahashi, H. and Ishikawa, T. "On failure mechanisms of composite laminates with an open hole subjected to compressive load", *Composites Science and Technology*, Vol. 66, 2006, pp. 634-641.
7. Li, Y., Li, M., Gu, Y. and Zhang, Z. "Numerical and Experimental Study on the Effect of Lay-Up Type and Structural Elements on Thickness Uniformity of L-Shaped Laminates", *Applied Composite Materials*, Vol. 16, 2009, pp. 101-115.
8. Guzman de Villoria, R., Hart, A.J. and Wardle, B.L. "Continuous High-Yield Production of Vertically Aligned Carbon Nanotubes on 2D and 3D Substrates", *ACS Nano*, Vol. 5, No. 6, 2011, pp. 4850-4857.
9. ASTM D 5961/D 5961M-08." Standard test method for bearing response of polymer matrix composite laminates", 2008.
10. Ravi B.D. and Charles R.S., "Composite materials: testing and design (twelfth volume)", ASTM International, Technology & Engineering, 1996, 422 pp.

11. Guzman de Villoria, R., Yamamoto, N., Miravete, A. and Wardle, B.L. "Multi-Physics Damage Sensing in Nano-Engineered Structural Composites", *Nanotechnology* Vol. 22, 2011, 185502 (7pp).
12. Cebeci, H., Guzman de Villoria, R., Hart, A.J. and Wardle, B.L. "Multifunctional properties of high volume fraction aligned carbon nanotube polymer composites with controlled morphology", *Composites Science and Technology* 69, 2009 pp.2649-2656.
13. Blanco, J., Garcia, E.J., Guzmán de Villoria, R., and B.L. Wardle, "Limiting Mechanisms in Mode I Interlaminar Toughness of Composites Reinforced with Aligned Carbon Nanotubes," *J. Composite Materials*, Vol. 43 (8), April 2009, pp. 825-842.