



Aalborg Universitet

AALBORG UNIVERSITY  
DENMARK

## Maritime DC Microgrids - A Combination of Microgrid Technologies and Maritime Onboard Power System for Future Ships

Jin, Zheming; Savaghebi, Mehdi; Quintero, Juan Carlos Vasquez; Meng, Lexuan; Guerrero, Josep M.

*Published in:*

Proceedings of 2016 8th International Power Electronics and Motion Control Conference - ECCE Asia (IPEMC 2016-ECCE Asia)

*DOI (link to publication from Publisher):*

[10.1109/IPEMC.2016.7512282](https://doi.org/10.1109/IPEMC.2016.7512282)

*Publication date:*

2016

*Document Version*

Early version, also known as pre-print

[Link to publication from Aalborg University](#)

*Citation for published version (APA):*

Jin, Z., Savaghebi, M., Quintero, J. C. V., Meng, L., & Guerrero, J. M. (2016). Maritime DC Microgrids - A Combination of Microgrid Technologies and Maritime Onboard Power System for Future Ships. In Proceedings of 2016 8th International Power Electronics and Motion Control Conference - ECCE Asia (IPEMC 2016-ECCE Asia) (pp. 179 - 184 ). IEEE. DOI: 10.1109/IPEMC.2016.7512282

### General rights

Copyright and moral rights for the publications made accessible in the public portal are retained by the authors and/or other copyright owners and it is a condition of accessing publications that users recognise and abide by the legal requirements associated with these rights.

- ? Users may download and print one copy of any publication from the public portal for the purpose of private study or research.
- ? You may not further distribute the material or use it for any profit-making activity or commercial gain
- ? You may freely distribute the URL identifying the publication in the public portal ?

### Take down policy

If you believe that this document breaches copyright please contact us at [vbn@aub.aau.dk](mailto:vbn@aub.aau.dk) providing details, and we will remove access to the work immediately and investigate your claim.

# Maritime DC Microgrids - A Combination of Microgrid Technologies and Maritime Onboard Power System for Future Ships

Zheming Jin, Mehdi Savaghebi, Juan C. Vasquez, Lexuan Meng, Josep M. Guerrero  
Microgrid Research Programme ([www.microgrids.et.aau.dk](http://www.microgrids.et.aau.dk)), Department of Energy Technology  
Aalborg University, Aalborg, Denmark  
{zhe,mes,juq,lem,joz}@et.aau.dk

**Abstract**— DC power distribution system is being considered as an attractive alternative to its traditional AC counterpart in many fields of applications and, in particular, for maritime onboard power systems. The adoption of DC power architecture would bring a broad range of benefits to the onboard power system. Not only frequency-related constraints are eliminated, which allows high-speed smaller generators to be used, but also new fault-tolerant configurations involving power electronics, generation control, as well as smart systemic management. For these reasons, DC power systems become natural alternative to the conventional AC power systems in the field of future maritime applications. Moreover, the inevitable cabin structure of maritime applications naturally separate the large-scale power system into several zonal parts. Furthermore, it is expected that the zonal parts can maintain autonomous power supply for a short time, which make the system highly consist with DC microgrids. In this content, it is foreseeable that the advanced research outcomes in the field of DC microgrid are also compatible with maritime onboard power systems. In this paper, DC power architectures, control and coordination methods, and specific issues of maritime onboard power system, fuel efficiency optimization and systemic reconfiguration are outlined, referring to state-of-the-art realizations as well as to novel concept designs presently under development and investigation.

**Keywords**— DC Microgrid; all-electric ships; integrated power systems; marine electrical power systems; power generation

## I. INTRODUCTION

Maritime power system can be traced back to the 1880s, starting with the earliest record of DC based shipboard power system at the *SS Columbia*, where Edison's DC lighting system was firstly installed. In the following century, maritime power system has developed greatly along with the increasing demand of onboard electrical power demands [1]. In the 1987, the refit of the *Queen Elizabeth II* made it become world's first cruise vessel using fully electric propulsion system as well as integrated diesel-electric power system, or in another word, the world's first all-electric ship (AES) in the real sense. One of the significant features of AES is the implementation of integrated power systems (IPSSs), which provide a common electrical platform of both propulsion power demand and ship-service loads. In broad terms, the IPSSs can be regarded as a

large-scaled shipboard microgrid, or a cluster of interconnected microgrids with several specific requirements.

So far, an overwhelming majority of existing AESs are using AC distribution based IPSSs (AC IPSSs). However, during its 30-year research and development, the inadequacies of AC IPSSs have been noticed by researchers and engineers, such as: the need of synchronization, unwanted problems of reactive power and harmonics. For these reasons, the long abandoned DC power architecture has return to shipbuilding industry's consideration. The most important potential benefits of DC distribution based IPSSs (DC IPSSs) are twofold: the improvement of fuel economy and the enhancement in reliability.

In case of commercial sector, the most important advantage of DC distribution based IPSSs (DC IPSSs) will be the elimination of synchronization problem, which allows the independent control of each generator set with variable speed range. This change will finally result in a significant reduction of fuel consumption [2]. In addition, energy storage systems (ESSs) can be easily integrated in DC IPSSs, and thus further reducing the fuel consumption [3]. Moreover, the relatively easy connection and disconnection lead to plug-and-play (PnP) ability as well as reconfigurable power architecture, which significantly enhance the survivability and reliability of the system [4].

Despite the benefits offered by DC IPS, it still leaves a challenging task to achieve voltage regulation in vessels' highly dynamic load conditions (especially during dynamic positioning operation) and real-time optimization of fuel economy in such a system at the same time. So far, the major control strategy of existing DC IPSSs inherits the excitation control of AC IPSSs. Judging by the fact that DC IPSSs can be regarded as a shipboard DC microgrid, thus the advanced research outcomes in DC microgrid field, especially its advanced control, management and optimization methods can be substituted into DC IPSSs. At present, the most commonly used control method of DC microgrid is droop control based hierarchical control architecture, in which the microgrids are controlled and coordinated by several control levels [6]. Within hierarchical control scheme, basic droop control could be achieved by local controllers; however, other control levels above droop control need to be achieved by coordination of all

distributed generators. For this reason, centralized, decentralized and distributed coordination control strategies have been investigated for terrestrial microgrids [7]. In this context, hierarchical control based control strategy can be adopted into DC IPSs with different reliability and redundancy requirement [8].

For maritime applications, several specific issues that could be solved easily in terrestrial power system need to be taken into consideration. Hence, the onboard power system is required to be highly reliable and fault-tolerant. At present, the shipbuilding industry applies “N+X” redundant power plant design and complex switchboards [1]. Since the DC based IPS could be regarded as a cluster of interconnected DC microgrids, it allows the entirety or part of on-board power system split into several natural cabin DC microgrids when a fault is detected. One step forward, the power system could be restored from these cabin DC microgrids [9]. The fault will be naturally isolated during this reconfiguration of the on-board power system, meanwhile, a significant advantage is that the power supply of healthy zones can not be interrupted [4].

This paper aims at employing research outcomes from DC microgrids research into maritime onboard DC power system, thus proposing forward-looking concepts. In Section II, onboard DC power architectures and onboard ESS are reviewed, moreover, their advantages are discussed, whereas in Section III, control and coordination of DC microgrid are categorized and presented. In Section IV, the role of smart management for efficiency improvement and fault-tolerant operation in onboard power system are discussed.

## II. DC POWER ARCHITECTURE AND ONBOARD ENERGY STORAGE

### A. Onboard DC Power Architecture

Queen Elizabeth II, the world’s first cruise vessel with electric propulsion system, is a high-profile example of existing AC shipboard power system. The power architecture of its shipboard power system is as shown in Fig. 1. During its over 30 years’ service, the inadequacies of Queen Elizabeth II’s power system have been noticed by researchers, such as: unwanted problems of reactive power, synchronization and harmonics as well as the problem of volume and weight [1].

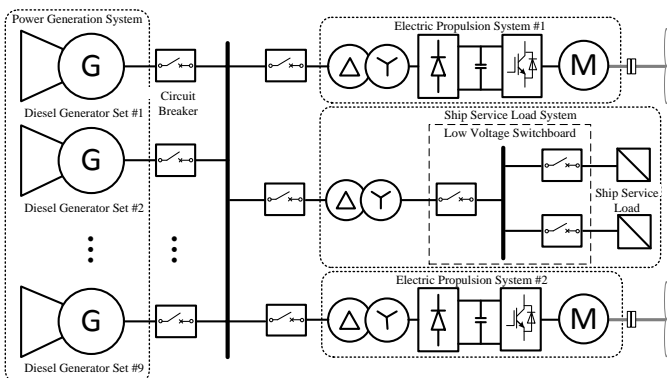

Fig. 1. Diesel-Electric Shipboard Power System of the *Queen Elizabeth II*

Thanks to the rapid development of modern power electronic technologies, high-frequency DC/DC converters have already enabled conveniently changing of voltage levels in DC systems. DC power system does have several major advantages while comparing with AC power system nowadays, such as easier parallel connection for DC power sources, elimination of synchronization, reactive power and harmonics, lower overall losses and weight, etc. Additionally, considering the specific need for maritime applications, DC based IPS could bring a broad range of advantages, for both commercial and for naval ships. The commercial sector focuses on the 15% fuel saving due to allowing variable speed diesel generators, whereas the military application are interested in support for advance electrical equipment and weapons, which characterized by high-power pulsed loads [10]. Due to the high power levels required in AES application, the only available design option for DC based IPS is the MVDC solution with a DC bus voltage above 1kV [4], which is highly consist with the trends of terrestrial DC microgrid in MVDC level.

Fig. 2 shows ring-bus based power architecture proposed for DC microgrids feeding critical load with higher security requirement (e.g. datacenter). The ring-bus allows energy flows along either shortest path or sub-optimal path, i.e. wherever single fault occurs in the system it can be isolated by switching off the nearest circuit breakers and other parts are able to work as normal. This feature guarantees the system survival from single-point-failure. In addition, the ring-bus would allow the critical load to obtain energy from multiple nodes by applying either conventional multiple contact point switch or multi-terminal converters. Accordingly, the critical load is highly secured to achieve uninterrupted operation.



Fig. 2. Ring-bus based DC microgrid feeding critical load.

A similar architecture can apply to the maritime power system but the inner part of the system will be divided into electrical zones corresponding to the feeds and it will typically be laid out with generational sources on the two sides, designated as port and starboard and with a simple cross-connect in the forward and aft parts of the system as shown in Fig. 3(a). Such a system is commonly referred to as DC Zonal Electrical System or DC ZEDs [11]. Fig. 3(b) shows the layout of equipment within an electrical zone. Fig. 3(c) is an alternative architecture of Fig. 3(a) in order to provide even higher reliability. If generators are distributed between buses, this architecture provides an opportunity for operation with a high power quality inside bus, dedicated to feeding the low voltage systems within the zones under normal conditions and

a lower quality bus on the outside that is dedicated to high power loads and pulsed loads. These two buses can operate independently of each other. The architecture offers an opportunity for efficiency improvement in the ship by allowing the output bus to operate at a lower voltage than the inner bus when it is not necessary to operate at full propulsion speed.

Highly reliable ring-bus based power architectures are usually preferred in the field of DC IPS. However, tradeoff always exists between reliability and complexity. The conventional single line power architectures are also a good choice of small-scaled vessels. Besides, complicated power architecture requires much more sophisticated control and coordination strategies, which needs to be carefully evaluated during early-stage design. Generally, the crucial guideline for power architecture design and selection should be on the basis of actual reliability and redundancy requirement.

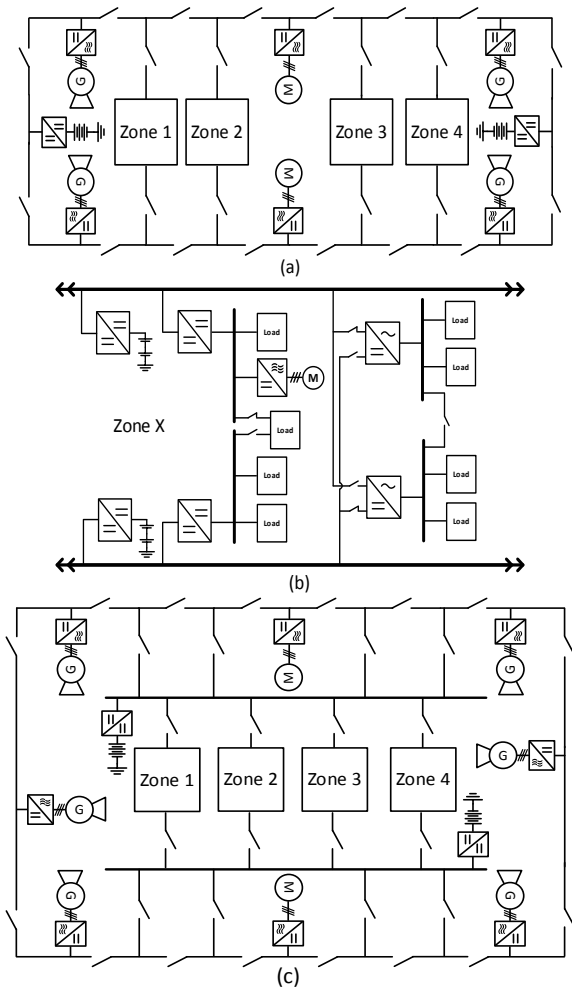

Fig. 3. Zonal electrical distribution system based power architecture (a) DC ZEDS (b) zonal load center (c) dual-ring-bus DC ZEDS

### B. Onboard Energy Storage System

Due to the soaring prices of fossil fuels as well as the practical need to integrate intermittent renewables into the next-generation power system, the energy storage technology

was one of the hottest research directions in the last decade. In emerging terrestrial microgrids, ESSs are absolutely required to guarantee reliability, security, stability and high power quality with the presence of highly intermittent energy sources and loads. However, the role of ESSs is seldom concerned in traditional power system. In recent studies, the role of ESSs in DC microgrids has already elevated to a new level, especially in islanding ones.

As for maritime applications, onboard ESSs could also act an important role in the IPS of next-generation AES. Considering diesel generation is still the major power source of maritime applications, the basic efficiency characteristic of diesel generation is the non-linear behavior of fuel efficiency versus load condition, however, there will always be a high-efficiency area in its full operation range as shown in Fig. 4. It therefore enables onboard ESSs modifying fuel efficiency by storing energy while system has lighter load and releasing stored energy in heavy load condition. In this way, it would be possible for diesel generators to always work with its maximum fuel efficiency. Meanwhile, the power quality of onboard power system might be enhanced.

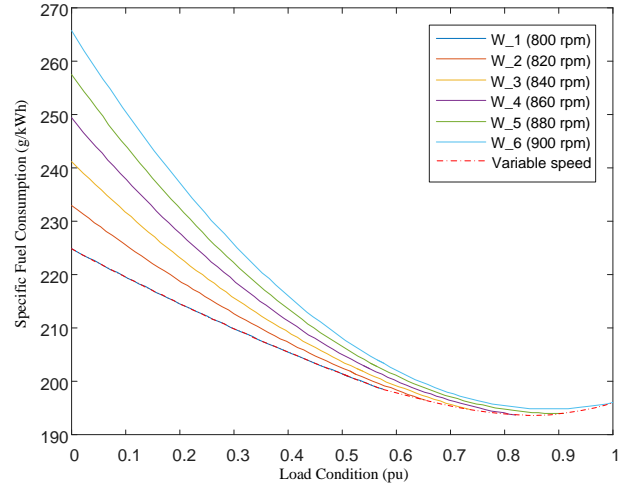

Fig. 4. Fuel efficiency characteristics of diesel generation.

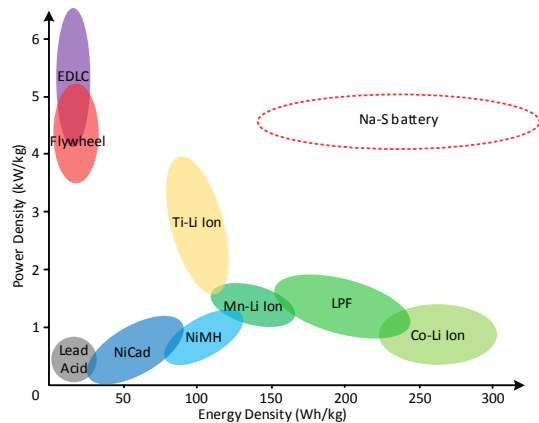

Fig. 5. Power density and energy density of different energy storage devices.

the mainstream energy storage devices' instantaneous power density and energy density is shown in Fig. 5. Since IPS for AES is a large-scaled system with complex loads, one potential solution will be distributed ESSs, which is based on a cluster of large or small ESSs using different kinds of energy storage devices. At present, the most likely dominant energy storage devices for maritime applications are battery, super capacitors (or formally named EDLC) and flywheel. By well-designed allocation and configuration, the onboard ESSs could enable multiple functions such as power backup, peak power shaving and braking energy recovery.

### III. CONTROL AND COORDINATION OF MICROGRID BASED POWER SYSTEM

#### A. Hierarchical control: the interface to future smart power system

As mentioned above, the combination of DC microgrid with DC IPS concept is privileged with many advantages, however, highly complicated control and coordination techniques are required to fully exploit its potential. After the rapid development in recent years, there are a series of advanced control and coordination techniques investigated for DC microgrids and are likely to be able to transplant to the DC IPS. At present, one of the most significant control and coordination techniques for microgrids is the hierarchical control, in which the microgrid system is controlled in the following levels [6]:

1) *Level 0 (inner control loops)*: The fundamental control loops to regulate the output voltage and/or current within each power electronic converters connected to the microgrid.

2) *Level 1 (primary control)*: The control methods to emulate the physical behaviors that make the system stable and more damped.

3) *Level 2 (secondary control)*: The control methods to ensure the major variables of the system are within the required values.

4) *Level 3 (initial tertiary control)*: The control methods to manage and control the power flow between the microgrids and its upper layer.

5) *Upper levels (extended tertiary control)*: The control and decision-making methods to achieve extra targets (i.e. practical economic benefits, etc.).

Fig. 6 shows a typical scheme of hierarchical control where the relationship between control levels is presented. Fig. 7 illustrates a typical architecture applying hierarchical control in the DC microgrid. Droop control is commonly installed as the primary control method for proactive power sharing purpose. In recent studies, either output power or output current could be selected as the feedback signal in the droop control. Secondary control and tertiary control are respectively responsible for quality of service and optimization. In hierarchical control, the higher the control level layers, the slower regulation it provides, the objective of control are also correspondingly more macroscopic, thus allowing intentional interacting in the power systems.

#### B. Centralized, decentralized or distributed coordination: scenario-based choices

For large scale DC microgrids, hierarchical control is often a preferred choice since it introduces independence between different control layers. However, hierarchical control is achieved by simultaneously using local control of the power electronic interfaces as well as the coordination among all these components. Judging by this fact, the local control and coordinated control strategies are equally important for the operation of DC microgrids. Generally, the secondary and tertiary control levels are depending on the coordination methods to form coordinated control of the entire DC microgrid. According to their different communication modes, coordination methods could be divided into three categories: centralized, decentralized and distributed.

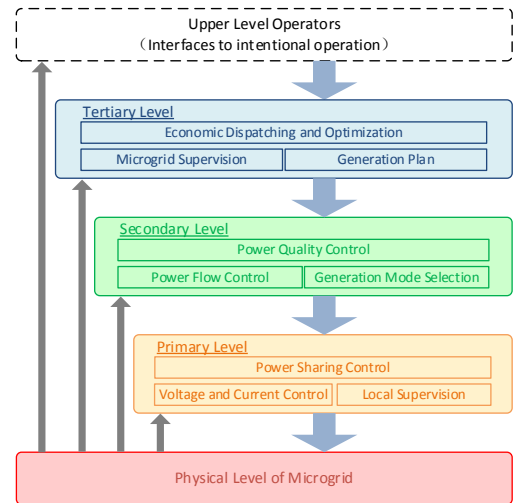

Fig. 6. Different control levels in the hierarchical control.

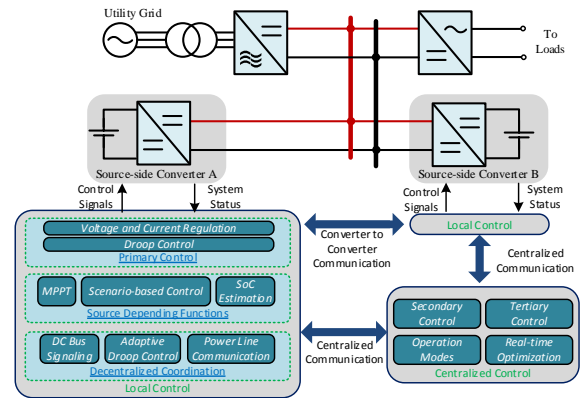

Fig. 7. Hierarchical control of a DC microgrid.

Centralized coordination control can be implemented in DC microgrids by employing a central controller and a communication network. In small scale DC microgrids, each unit can be directly controlled by the central controller via high bandwidth communication using master/slave method. It should be noted that centralized control provides the best foundation for the advanced control functionalities as well as



system-level optimization since all relevant data can be collected and processed within a single controller. However, the cost and difficulty to implement centralized control would increase nonlinearly with the increasing number of accessed components.

Decentralized coordination control is achieved exclusively by the local controllers of power electronic interfaces. The obvious advantage of decentralized coordination is its independence from the communication and central controller. However, this advantage in reliability results in inherent performance limitations due to the lack of information from other units as the price. At recent studies, DC bus signal (DBS) method, adaptive droop control and power line signal (PLS) method have been proposed as decentralized coordination method. Among them, DBS is now the most promising one for DC microgrids [7].

Comparing with the centralized and decentralized coordination control, distributed coordination is more likely compromise of these two coordination methods, where central controller does not exist but local controller could communicate among themselves. The most important distributed coordination method is multi-agent systems (MAS) in which each local controller could be regarded as an intelligent agent and all agents compose MAS together [7]. By applying consensus algorithm it could achieve information awareness comparable to that of centralized control and offer possibility to apply wider functionalities than decentralized control, meanwhile, it maintains the high reliability of decentralized control.

#### IV. SMART GRID TECHNOLOGIES, THE KEY TO SMART ON-BOARD POWER SYSTEM

##### A. *Smart coordinated management for lower cost and less emission*

Recently, the common trend of future power systems is moving toward intelligent and efficient. As the fundamental of future smart grid, intelligent management concepts, i.e. supervisory energy management, have been introduced to microgrid as an extension of the conventional hierarchical control architecture. Since one of the initial intention of AES is to enhance the fuel efficiency of the vessel and to reduce the environmental impact as well, intelligent management would be seamlessly introduced to IPS in order to develop future smart AES.

For on-board power system, generally the voyage or mission of a vessel could always be generally divided into several operating scenarios, such as docking, acceleration, deceleration, cruise, etc., moreover, the scenarios will change in a certain order. Judging by this important fact, pre-planned on-board energy management and its optimization would be applicable to coordinate the on-board generation and ESSs for optimal fuel efficiency. In recent years, International Maritime Organization is making effort in promoting this method as Ship Energy Efficiency Management plan (SEEMP), and it may be required for each vessel in the near future. With reasonable assumptions, advanced offline optimization algorithms could be used to improve the design of SEEMP,

however, the practical operation of vessel may have to face innumerable contingencies, which make grouped mid-term scenario-based SEEMPs promising in the practical operation. The most attractive objectives of SEEMP might be maximum fuel-efficiency and emission limitation, which requires cooperative management from both generation side and demand side.

The role of ESSs in the SEEMP would be extremely important due to its precious bidirectional characteristic. The presence of ESSs breaks the conventional dependency of generation and demand sides; furthermore, it significantly improves the maneuverability of SEEMP. Besides that, it should be noted that the electric propulsion could also act as generation while going regenerative braking. Traditional method could not deal with such kind of bi-directional loads and the excess energy would be dissipated on dumping resistors in order to keep the stability of the power system. With the help of ESSs, this part of energy could be partly or fully stored, thus, it help reduce the overall cost. One step further, ESSs themselves could also play the role of only power source of short-term voyage, which may significantly reduce the environmental impact of vessels, especially in ports.

##### B. *Smart protection and reconfiguration for fault-tolerant and highly reliable system*

The protection of DC IPS, especially those with DCZEDS configuration, is a challenging task as the healthy zones should not be isolated while power supply to critical loads should not be intermittent. Besides that, since zones are interconnected in the DCZEDS, a single point failure may spread and upgrade into regional failure or systemic crash if the protection is not effective enough. At present, the fault detection and protective activities are usually done by the power electronic converters and/or protective devices. In order to achieve fast response protection, supervision diagnosis system has been exploited in DC microgrid. Besides that, smart fault detection methods are under investigation [12].

The reconfiguration capability is one of the most promising advantages of MVDC IPS, especially for naval applications. However, the non-linear multi-connectivity and high-dimensionality of the onboard power system make it difficult to achieve fast and efficient reconfiguration. In this context, the self-healing reconstruction method, which firstly sub-divides the power system into several zonal microgrids and then reconstructs it from microgrids, is currently promising in the field of DC IPS [9]. The sectionalizing aims at the minimization of the isolated area and maintaining the power supply to healthy zones at the same time. Further, the sectionalized zonal microgrids will attempt to connect with each other and form networked microgrids, which can improve the operation and the reliability. In this way, the power system will recover from the fault in several steps and isolate the fault location at the same time. So far, reconfiguration methodologies have become a popular research direction in the field of naval shipboard power system. Several methods on the basis of MAS or supervision system have been proposed. However, the optimally

sectionalizing is still a challenging task, researches about the selection of optimal power flow path, the awareness of global information, the estimation of load changing and the quality of power supply in sectionalized microgrids are still to be performed.

## V. CONCLUSION

Heretofore, DC-based maritime onboard power system has not been widely promoted, but it is expected to be intensified in the near future for both military and commercial vessels. At present, terrestrial utility power system and maritime onboard power system are developing toward their more intelligent and more efficient form. Microgrid, as fundamental of future smart power system, is now becoming the new enabling technology for the other large or small, stationary or onboard emerging applications. DC based IPS for future AES is a promising combination of AES concept and DC microgrid. The authors believe that the contribution of the DC microgrid research in maritime applications will keep increasing in the near future.

## REFERENCES

- [1] Dale, S.J.; Hebner, R.E.; Sulligoi, G., "Electric Ship Technologies," in Proceedings of the IEEE , vol.103, no.12, pp.2225-2228, Dec. 2015
- [2] Hansen, J.F., Lindtjorn, J.O., Myklebust, T.A., Vanska, K.: "Trends in technology: onboard DC grid" in ABB review 2/12, pp. 29-33, Available on: <http://www.abb.com/abbreview>
- [3] Kanellos, F.D.; Tsekouras, G.J.; Prousalidis, J., "Onboard DC grid employing smart grid technology: challenges, state of the art and future prospects," in Electrical Systems in Transportation, IET , vol.5, no.1, pp.1-11, 3 2015
- [4] IEEE Recommended Practice for 1 kV to 35 kV Medium-Voltage DC Power Systems on Ships," in IEEE Std 1709-2010 , vol., no., pp.1-54, Nov 2010.
- [5] S. Y. Kim, S. Choe, S. Ko and S. K. Sul, "A Naval Integrated Power System with a Battery Energy Storage System: Fuel efficiency, reliability, and quality of power.," in IEEE Electrification Magazine, vol. 3, no. 2, pp. 22-33, June 2015.
- [6] Guerrero, J.M.; Vasquez, J.C.; Matas, J.; de Vicuña, L.G.; Castilla, M., "Hierarchical Control of Droop-Controlled AC and DC Microgrids—A General Approach Toward Standardization," in Industrial Electronics, IEEE Transactions on , vol.58, no.1, pp.158-172, Jan 2011.
- [7] C. Dou; D. Yue; J. M. Guerrero; X. Xie; S. Hu, "Multiagent System-Based Distributed Coordinated Control for Radial DC Microgrid Considering Transmission Time Delays," in IEEE Transactions on Smart Grid , Early Access, 2016
- [8] Sulligoi, G.; Vicenzutti, A.; Tironi, E.; Corti, M.; Lamedica, R.; Ruvio, A.; Lipardi, G.; Piva, L., "Naval smart grid: Integrated Power System for all electric naval vessels with control and reliability characteristics," in AEIT Annual Conference - From Research to Industry: The Need for a More Effective Technology Transfer (AEIT), 2014 , vol., no., pp.1-6, 18-19 Sept. 2014
- [9] Butler-Purry, K.L.; Sarma, N.D.R., "Self-healing reconfiguration for restoration of naval shipboard power systems," in Power Systems, IEEE Transactions on , vol.19, no.2, pp.754-762, May 2004
- [10] M. Steurer et al., "Investigating the Impact of Pulsed Power Charging Demands on Shipboard Power Quality," 2007 IEEE Electric Ship Technologies Symposium, Arlington, VA, 2007, pp. 315-321.
- [11] Cuzner, R.M.; Esmaili, D.A., "Fault tolerant shipboard MVDC architectures," in Electrical Systems for Aircraft, Railway, Ship Propulsion and Road Vehicles (ESARS), 2015 International Conference on , vol., no., pp.1-6, 3-5 March 2015
- [12] R. M. Cuzner and G. Venkataramanan, "The Status of DC Micro-Grid Protection," Industry Applications Society Annual Meeting, 2008. IAS '08. IEEE, Edmonton, Alta., 2008, pp. 1-8