



Aalborg Universitet

AALBORG UNIVERSITY
DENMARK

Convergence Analysis of Distributed Control for Operation Cost Minimization of Droop Controlled DC Microgrid Based on Multiagent

Li, Chendan; Quintero, Juan Carlos Vasquez; Guerrero, Josep M.

Published in:

Proceedings of the 31st Annual IEEE Applied Power Electronics Conference and Exposition (APEC)

DOI (link to publication from Publisher):

[10.1109/APEC.2016.7468364](https://doi.org/10.1109/APEC.2016.7468364)

Publication date:

2016

Document Version

Early version, also known as pre-print

[Link to publication from Aalborg University](#)

Citation for published version (APA):

Li, C., Quintero, J. C. V., & Guerrero, J. M. (2016). Convergence Analysis of Distributed Control for Operation Cost Minimization of Droop Controlled DC Microgrid Based on Multiagent. In Proceedings of the 31st Annual IEEE Applied Power Electronics Conference and Exposition (APEC) (pp. 3459 - 3464). IEEE. DOI: 10.1109/APEC.2016.7468364

General rights

Copyright and moral rights for the publications made accessible in the public portal are retained by the authors and/or other copyright owners and it is a condition of accessing publications that users recognise and abide by the legal requirements associated with these rights.

- ? Users may download and print one copy of any publication from the public portal for the purpose of private study or research.
- ? You may not further distribute the material or use it for any profit-making activity or commercial gain
- ? You may freely distribute the URL identifying the publication in the public portal ?

Take down policy

If you believe that this document breaches copyright please contact us at vbn@aub.aau.dk providing details, and we will remove access to the work immediately and investigate your claim.

Convergence Analysis of Distributed Control for Operation Cost Minimization of Droop Controlled DC Microgrid Based on Multiagent

Chendan Li, Juan C. Vasquez, and Josep M. Guerrero
Department of Energy Technology, Aalborg University
Aalborg, Denmark
{che, juq, joz}@et.aau.dk
(<http://www.et.aau.dk/research-programmes/microgrids>)

Abstract—In this paper we present a distributed control method for minimizing the operation cost in DC microgrid based on multiagent system. Each agent is autonomous and controls the local converter in a hierarchical way through droop control, voltage scheduling and collective decision making. The collective decision for the whole system is made by proposed incremental cost consensus, and only nearest-neighbor communication is needed. The convergence characteristics of the consensus algorithm are analyzed considering different communication topologies and control parameters. Case studies verified the proposed method by comparing it without traditional methods. The robustness of system is tested under different communication latency and plug and play operation.

Keywords— *economic dispatch problem; operation cost minimization; droop control; DC microgrid; voltage scheduling; incremental cost consensus; multiagent.*

I. INTRODUCTION

Microgrids are the future of the distribution system in smart grid. The cluster of the loads, distributed generators and energy storage system within a defined boundary, through coordinated control, can provide higher reliability, flexibility and efficiency to both the end-users within the grid and the upper grid through ancillary services. Although most of the existed microgrids are based on AC delivery scheme since this scheme has been the paradigm dominated in the traditional power system, DC microgrid is continuously demonstrating the advantages in terms of higher flexibility, power quality and lower power loss compared with AC microgrid [1]-[3]. In fact, most of end-user loads need embedded rectifiers to convert the power to DC from the original AC, such as computer, LED lights, and so on. Moreover, on the generation side, solar generation system and energy storage system are all DC sources. A DC distribution system therefore can reduce the capital cost as well as provide added valued mentioned above.

Besides providing increased reliability, power quality, the potential of a microgrid to offer increased efficiency is gaining more interests with the technology becoming more and more mature [4]-[11]. As the generation resources of microgrid can be quite heterogeneous, one of the optimization

objects is to reduce the operation cost of the system through optimal dispatch according to the different operation cost of each generator. To achieve this goal, control strategies can be either centralized or decentralized. Authors in [4] used a centralized controller to reduce the operation cost through reduced gradient method. Authors in [5] provided optimized droop parameter through optimal power flow for the DC microgrid, which needs a centralized controller to run the power flow and optimization. Although applications realized in centralized way with a single centralized controller can achieve the operation cost minimization of system, they suffer from the single point of failure [6].

Instead, reference [7] and [8] provided the cost-based droop to optimize the operation cost in the primary control level in a distributed way. However, although it will reduce the total cost, the optimum cannot be guaranteed since it makes the linearization of the cost function by approximation. In [9], author adopted incremental cost consensus to optimize the system in a smart grid context, but the details of power regulation realization are not given. In [10] and [11], authors implemented a distributed optimization method based on incremental cost for the system, but it was applied to AC microgrid.

In this paper, a multiagent system is designed aiming at minimizing the operation cost of the DC microgrid. Each local controller for each converter is taken as an agent. The control strategy is detailed to the primary control level based on droop, and the power regulation is realized through voltage scheduling. The optimal power command is generated in a distributed way. Practical issues regarding the interoperation of the low band communication are investigated.

The rest of the paper is organized as follows. Section II introduces the general structure of a DC microgrid. The overall control system is described in Section III, which elaborate the problem formulation, incremental consensus algorithm and power regulation using voltage scheduling method. Case studies of the proposed design follow in Section IV. In the end, Section V concludes the paper.

II. DC MICROGRID CONFIGURATION

Fig. 1 shows a typical DC microgrid with distributed control system studied in this work. The DC microgrid contains renewable resource and load, and other dispatchable distributed generators acting as the backup for the intermittent renewables. Each dispatchable generator is interfaced with a DC/DC converter between the primary source and the DC bus. This DC microgrid is a cyber-physical system which has the controllers and communication system being the computational elements upon the physical components in the fleet.

Conventionally, there is an extra centralized controller which computes for the upper layer functions above the primary control, such as economic dispatch and voltage regulation. In this work, optimization is applied to the dispatchable distributed generators. Each their local controller itself will work as an autonomous controller to collaboratively accomplish the optimization of the system.

III. PROPOSED MULTIAGENT SYSTEM

A. Optimization Problem Formulation

The generation costs of different DGs (fuel cells, batteries, diesel generators, etc.) include many factors, which are surely not the same, but they might have a similar pattern which can be generalized as quadratic cost function [6]-[11].

During operation, assume the cost only incurred due to the fuel cost or the power loss incurred by charging/discharging efficiency of the energy storage system. The generation cost of each dispatchable generator can be generalized into:

$$C_i(P_{G,i}) = \alpha_i P_{G,i}^2 + \beta_i P_{G,i} + \gamma_i \quad (1)$$

where α_i , β_i and γ_i are the coefficient of cost function of DG unit i ,

Assuming there are n dispatchable generators in the microgrid. The total cost of operation of a microgrid can be expressed as

$$C_{total} = \sum_{i=1}^n C_i(P_{G,i}) = \sum_{i=1}^n \alpha_i P_{G,i}^2 + \beta_i P_{G,i} + \gamma_i \quad (2)$$

The optimization problem should be constrained by the power balance equation and power generation limitation, and therefore the objective function for minimizing the operation cost can be written as

$$\begin{aligned} & \text{Min} \sum_{i=1}^n \alpha_i P_{G,i}^2 + \beta_i P_{G,i} + \gamma_i \\ & \text{s.t.} \quad \sum_{i=1}^n P_{G,i} = P_D \\ & \quad \quad P_{G,i}^{\min} \leq P_{G,i} \leq P_{G,i}^{\max} \end{aligned} \quad (3)$$

where $P_{G,i}$ denotes the output power of unit i , and P_D denotes the total power demand of the system.

This optimization above can be solved in a centralized control system using Lagrange multiplier method [9]. In this work, a distributed control method based on multiagent is adopted using incremental cost consensus, which is elaborated in the next part.

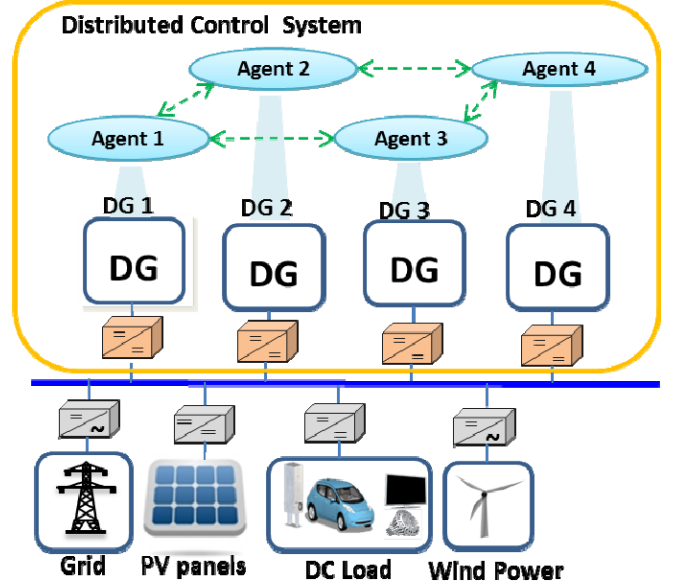

Fig. 1 Example DC microgrid controlled by multiagent system

B. Incremental Cost Consensus

1) Incremental Cost

Same as conventional economic dispatch method, the incremental cost of each DG is defined as

$$r_i = \frac{\partial C_i(P_{G,i})}{\partial P_{G,i}} = 2\alpha_i P_{G,i} + \beta_i \quad (4)$$

Without generation capacity constraints, when the incremental cost reaches equality, it is the solution to (3). The common optimal r^* can be expressed as

$$r^* = \left[\sum_{i=1}^n \frac{\beta_i}{2\alpha_i} + P_D \right] / \left(\sum_{i=1}^n \frac{1}{2\alpha_i} \right) \quad (5)$$

2) Update Rules of Consensus Algorithm

In this distributed control strategy, the update rule of proposed incremental consensus algorithm is as follows.

$$r_i[t+1] = \sum_{j \in N_i} d_{ij} r_j + \varepsilon P_{D,i}[t] \quad (6)$$

$$P_{G,i}[t+1] = \frac{r_i[t+1] - \beta_i}{2\alpha_i} \quad (7)$$

$$P_{D,i}^s[t+1] = P_{D,i}[t] - (P_{G,i}[t+1] - P_{G,i}[t]) \quad (8)$$

$$P_{D,i}[t+1] = \sum_{j \in N_i} d_{ij} P_{D,i}^s[t+1] \quad (9)$$

where $r_i[t]$ is the incremental cost of agent i at iteration t , ε is the feedback coefficients which controls the convergence of the consensus, $P_{D,i}[t]$ is the estimation of the global supply-demand mismatch, and d_{ij} is defined as

$$d_{ij} = \begin{cases} 2 / (n_i + n_j + 1) & j \in N_i \\ 1 - \sum_{j \in N_i} 2 / (n_i + n_j + 1) & i = j \\ 0 & \text{otherwise} \end{cases} \quad (10)$$

3) Convergence characteristics of consensus algorithm

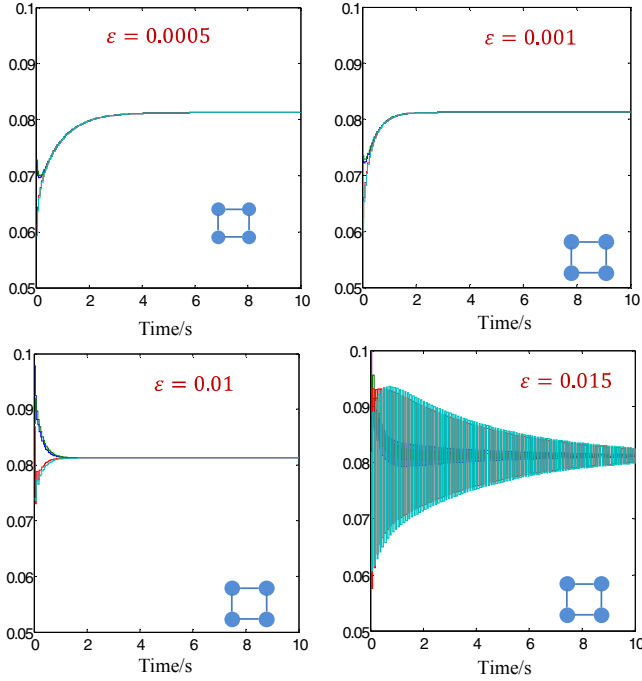

Fig. 2 Convergence analysis with different ϵ

To analyze the dynamics of the proposed consensus algorithm, several factors that influence the system are investigated in this part in order to guide the system design.

Firstly, the impact of the control parameter in the consensus algorithm is analyzed. Fig. 2 shows the convergence characteristic with different ϵ . It can be seen that, as ϵ becomes smaller the convergence will become slower. However, it cannot be unlimitedly large. When parameter ϵ reaches 0.015, the consensus algorithm cannot converge. Thus, the convergence speed and stability of the

consensus algorithm is a trade-off when choosing the parameter.

Secondly, the impact of different topologies to the consensus is also studied. Fig. 3 shows that the convergence characteristic of the proposed algorithm under different topologies. As it can be seen, the more connected, the faster the system converges. When designing the communication system, the latency tolerance and the cost should be weighed.

Since the latency in the communication only influence how fast in each update during the convergence, it will not affect the convergence of the system. However, in the whole control system, the effect of it should not be overlooked and it will be addressed in the case studies of the whole system.

C. Power regulation base on voltage scheduling

The basic droop control for DC microgrid uses a virtual impedance to regulate the output voltage so as to regulate output power of DG units, which can be expressed as [12]-[14]

$$V_{o_i} = V_{ref,i} - R_{d,i} i_{o,i} \quad (11)$$

where V_{o_i} is the voltage command given to the voltage loop of the converter i , $V_{ref,i}$ is the voltage reference for the droop controller and $R_{d,i}$ is the virtual impedance, and $i_{o,i}$ is the output current.

Instead of changing $R_{d,i}$, $V_{ref,i}$ is modified directly based on the power command in this work. This control strategy actually does not only maintains the benefit of traditional droop control to avoid power circulation, but also realizes accurate power sharing if power command is correctly given. The voltage reference is modified as (12), and the control diagram is given in Fig. 4.

$$V_{ref,i} = V^* + Kp(P_{G,i}^* - P_{G,i}) + Ki \int (P_{G,i}^* - P_{G,i}) \quad (12)$$

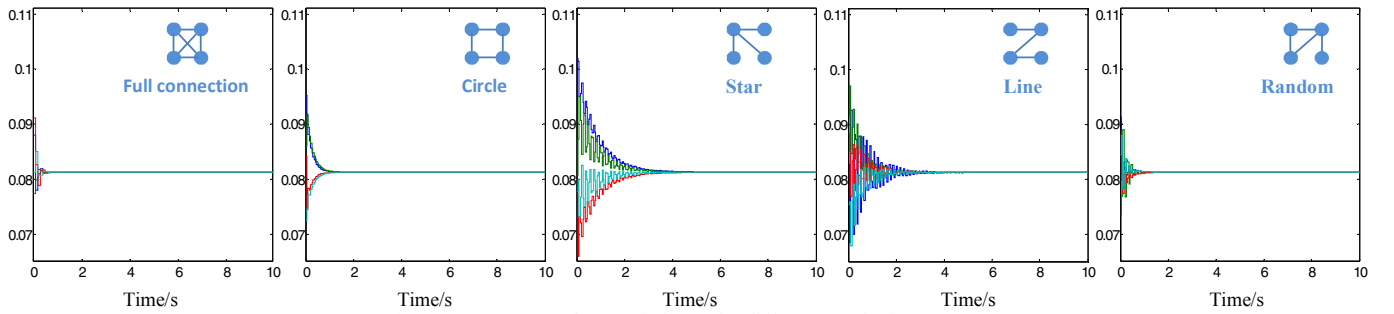

Fig. 3 Convergence characteristics under different topologies

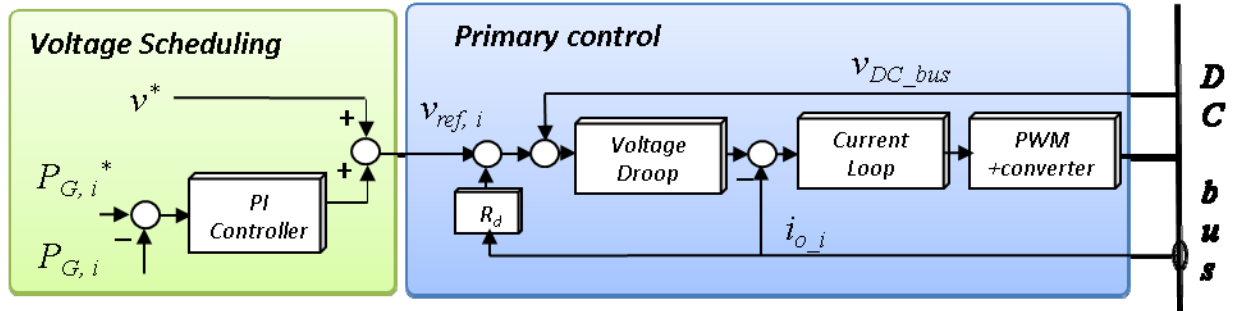

Fig. 4 Control diagram of power regulation

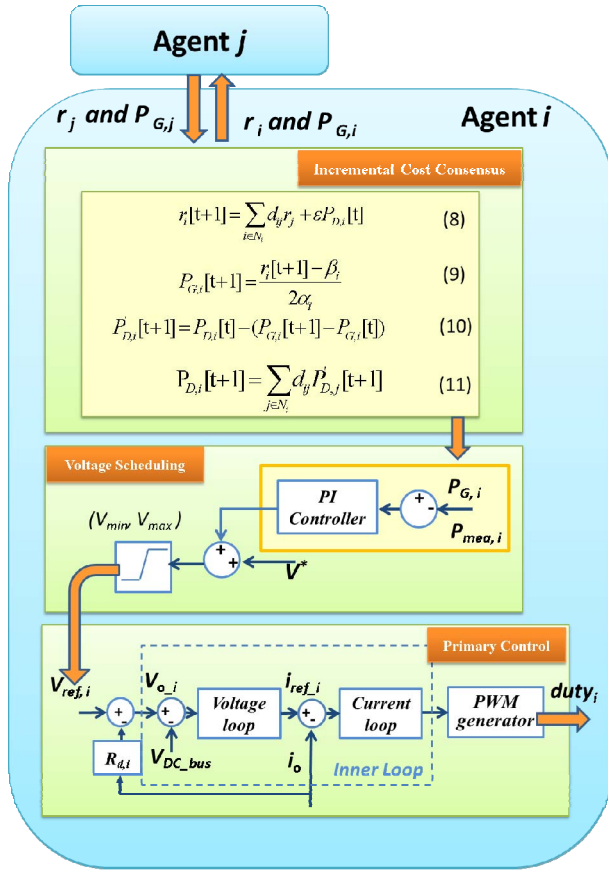

Fig. 5 Proposed multiagent system

TABLE I CONTROL PARAMETER

Item	Symbol	Value
Nominal bus voltage	V^*	400V
Minimum bus voltage	V_{min}	420V
Maximum bus voltage	V_{max}	380V
Virtual impedance for DG1,3	$R_{d,1}, R_{d,3}$	0.2Ω
Virtual impedance for DG2,4	$R_{d,2}, R_{d,4}$	0.5Ω
Voltage scheduling proportional term	K_p	0.0009
Voltage scheduling integral term	K_i	0.001s ⁻¹
Consensus convergence coefficient	ε	0.001

TABLE II COEFFICIENTS OF THE OPERATION COST FUNCTION

Unit	α_i	β_i	γ_i
1	7.15e-3	0.77	0.002
2	4.75e-3	0.78	0.005
3	3.75e-3	0.55	0.001
4	3.45e-3	0.51	0.001

D. Overall distributed control system

The control diagram of the proposed strategy is illustrated in Fig. 5. Here we illustrate the multiagent system using two arbitrary agents which have communication connection between each other.

Each agent is controlling their local converter through hierarchical control structure, and only its own incremental cost and power command generated in the iteration of the consensus algorithm are exchanging between them, which are needed for the convergence of the consensus. Below

consensus layer using communication, there is the power regulation loop which uses voltage scheduling to track the optimal power command. In the primary control, each converter is using virtual impedance to sharing the power.

IV. CASE STUDIES

A. Performance comparison with traditional method

To verify the effectiveness of the control strategy, the proposed method is simulated in a tested DC microgrid with four different dispatchable generators. The control parameters of the DC microgrid are listed in Table I. The cost coefficients of the generators are given in Table II.

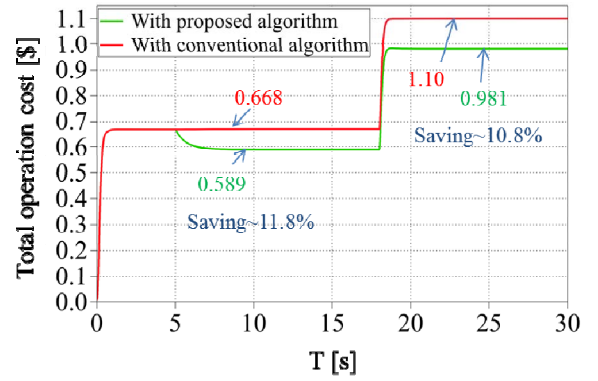

(a)

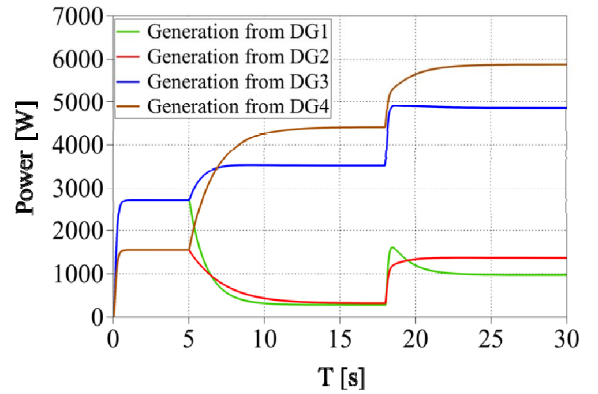

(b)

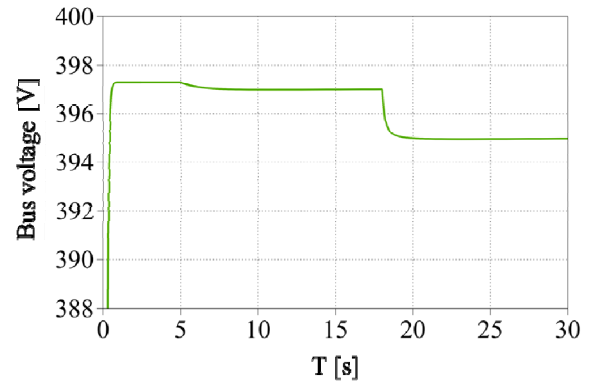

(c)

Fig. 6 Controller performance (a) Total operation cost, (b) Generation power of each DG unit and (c) DC bus voltage

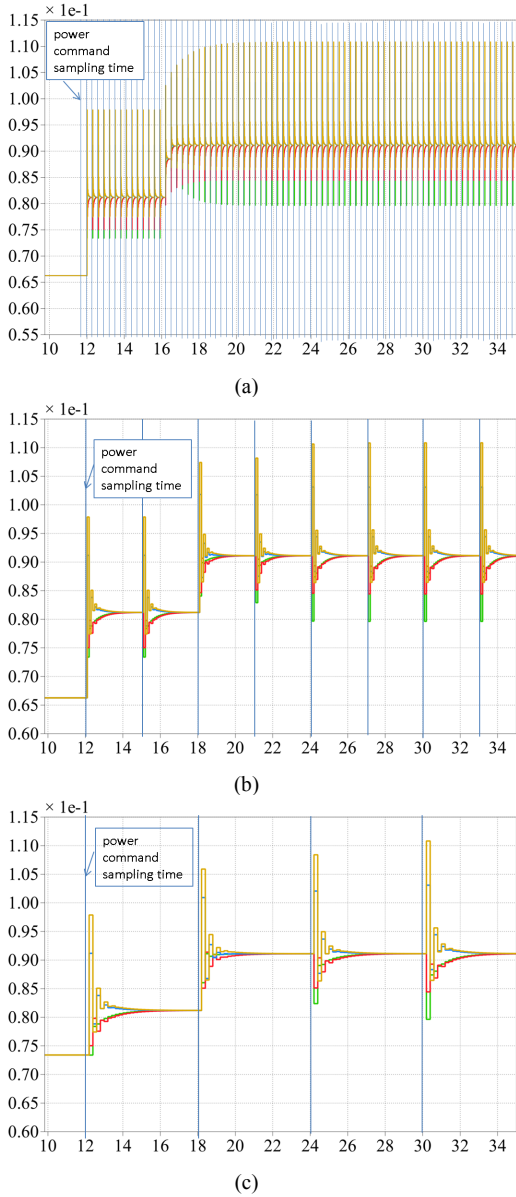

Fig. 7 Power command with (a) 10ms, (b) 100ms and (c) 200ms latency

Firstly, only traditional droop is adopted at the beginning. The proposed operation cost minimization method is activated at $t = 5$ s. To test the system during the load change, at $t = 18$ s, the total load of the system is changed from 8.5kW to 13kW. Fig. 6 (a) to (c) show the total operation cost of the system, generation of each DG unit and DC bus voltage. The total cost is reduced up to 11.8% compared with that using only the droop control in each converter with virtual impedance configured as in Table I. Fig. 6 (b) shows power shared among converters respectively, which are not identical because of the optimization.

B. Impact of Communication Latency

In this cyber-physical system, although the communication load is light, the condition of communication would influence the performances of the system. In this part,

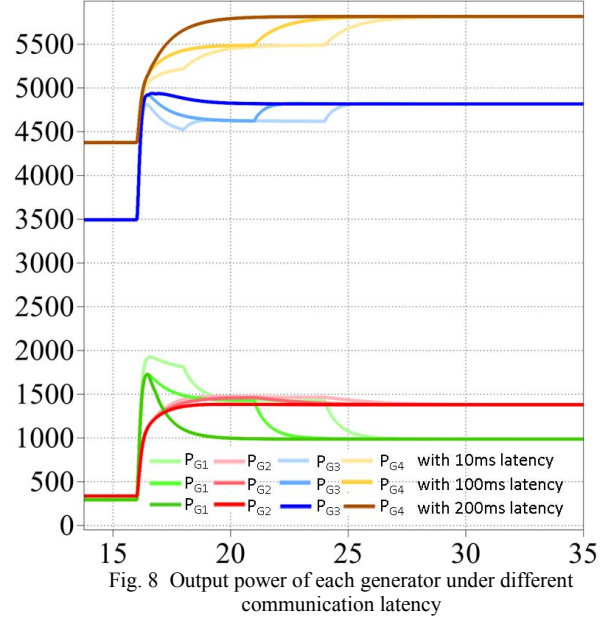

Fig. 8 Output power of each generator under different communication latency

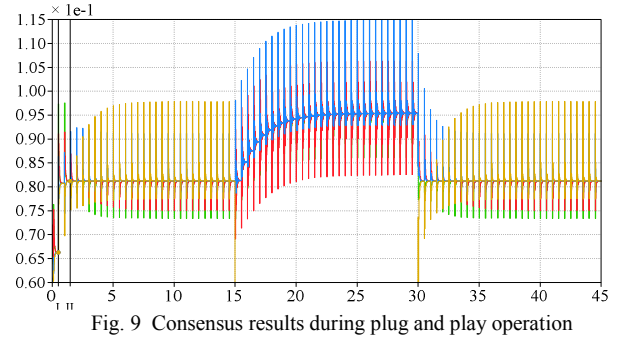

Fig. 9 Consensus results during plug and play operation

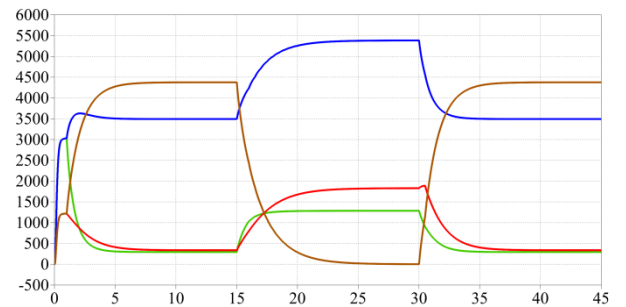

Fig. 10 Output power results during plug and play operation

the effect of communication latency is investigated. Same as last part, the load is changed from 8.5kW to 13kW at 16s. The system is tested under the communication with 10ms, 100ms and 200ms latency, respectively. The power command generated from consensus under different scenarios is shown in Fig. 7, which is passed to the lower level controller synchronously after consensus gets converged. It can be seen from Fig. 8, although the responses with longer latency get slower, the output power will reach the same value in the steady state.

C. Plug and play operation

To test the plug and play functionality of the multiagent system, DG unit 4 is cut in and out at $t=15s$ and $t=30s$. The optimization is activated at $t=1s$. Fig. 9 shows the consensus

V. CONCLUSION

In this paper, a multiagent system is proposed aiming at minimizing the operation cost for DC microgrids. Each local controller for each converter is taken as an agent, which optimizes the local converter autonomously in a hierarchical way with only communication with nearest neighbour. Compared with method without optimization, the operation cost is reduced effectively under different load conditions. The impact of communication issues on the multiagent system convergence is investigated to shed light on the system design. Experimental results are expected in the future work.

REFERENCES

- [1] Guerrero, J.M.; Vasquez, J.C.; Matas, J.; de Vicuña, L.G.; Castilla, M., "Hierarchical Control of Droop-Controlled AC and DC Microgrids—A General Approach Toward Standardization," *Industrial Electronics, IEEE Transactions on* , vol.58, no.1, pp.158,172, Jan. 2011; doi: 10.1109/TIE.2010.2066534
- [2] D. Salomonsson, Modeling , Control and Protection of Low-Voltage DC Microgrids. 2008, p. 66.
- [3] Yunjie Gu; Xin Xiang; Wuhua Li; Xiangning He, "Mode-Adaptive Decentralized Control for Renewable DC Microgrid With Enhanced Reliability and Flexibility," *Power Electronics, IEEE Transactions on* , vol.29, no.9, pp.5072,5080, Sept. 2014. Nicole, "Title of paper with only first word capitalized," J. Name Stand. Abbrev., in press.
- [4] N. Augustine, S. Suresh, P. Moghe, and K. Sheikh, "Economic dispatch for a microgrid considering renewable energy cost functions," in *2012 IEEE PES Innovative Smart Grid Technologies (ISGT)*, 2012, pp. 1–7.
- [5] Chendan Li; de Bosio, F.; Chaudhary, S.K.; Graells, M.; Vasquez, J.C.; Guerrero, J.M., "Operation Cost Minimization of Droop-Controlled DC Microgrids Based on Real-Time Pricing and Optimal Power Flow," in *Industrial Electronics Society, IECON 2015- 40th Annual Conference of the IEEE* , in press.
- [6] Meng, L.; Dragicevic, T.; Roldan-Perez, J.; Vasquez, J.C.; Guerrero, J.M., "Modeling and Sensitivity Study of Consensus Algorithm-Based Distributed Hierarchical Control for DC Microgrids," in *Smart Grid, IEEE Transactions on* , vol.PP, no.99, pp.1-1
- [7] Nutkani, I.U.; Poh Chiang Loh; Blaabjerg, F., "Droop Scheme With Consideration of Operating Costs," *Power Electronics, IEEE Transactions on* , vol.29, no.3, pp.1047,1052, March 2014
- [8] Nutkani, I.U.; Wang Peng; Poh Chiang Loh; Blaabjerg, F., "Cost-based droop scheme for DC microgrid," in *Energy Conversion Congress and Exposition (ECCE), 2014 IEEE* , vol., no., pp.765-769, 14-18 Sept. 2014
- [9] Ziang Zhang; Mo-Yuen Chow, "Convergence Analysis of the Incremental Cost Consensus Algorithm Under Different Communication Network Topologies in a Smart Grid," *Power Systems, IEEE Transactions on* , vol.27, no.4, pp.1761,1768, Nov. 2012
- [10] S. Yang, S. Tan, and J.-X. Xu, "Consensus Based Approach for Economic Dispatch Problem in a Smart Grid," *IEEE Trans. Power Syst.*, vol. 28, pp. 4416–4426, 2013.
- [11] Chendan Li; Savaghebi, M.; Vasquez, J.C.; Guerrero, J.M., "Multiagent based distributed control for operation cost minimization of droop controlled AC microgrid using incremental cost consensus," in *Power Electronics and Applications (EPE'15 ECCE-Europe)*, 2015 17th European Conference on , vol., no., pp.1-9, 8-10 Sept. 2015
- [12] Shafiee, Q.; Dragicevic, T.; Vasquez, J.C.; Guerrero, J.M., "Hierarchical Control for Multiple DC-Microgrids Clusters," in *Energy Conversion, IEEE Transactions on* , vol.29, no.4, pp.922-933, Dec. 2014
- [13] Dong Chen; Lie Xu; Liangzhong Yao, "DC network stability and dynamic analysis using virtual impedance method," *IECON 2012 - 38th Annual Conference on IEEE Industrial Electronics Society* , vol., no., pp.5625,5630, 25-28 Oct. 2012
- [14] Dragicevic, T.; Lu, X.; Vasquez, J.; Guerrero, J., "DC Microgrids—Part I: A Review of Control Strategies and Stabilization Techniques," in *Power Electronics, IEEE Transactions on* , vol.PP, no.99, pp.1-1