



Aalborg Universitet

AALBORG UNIVERSITY
DENMARK

Circulating current controller for parallel interleaved converters using PR controllers

Bede, Lorand; Gohil, Ghanshyamsinh Vijaysinh; Ciobotaru, Mihai; Kerekes, Tamas;
Teodorescu, Remus; Agelidis, Vassilios G

Published in:

Proceedings of the 41th Annual Conference of IEEE Industrial Electronics Society, IECON 2015

DOI (link to publication from Publisher):

[10.1109/IECON.2015.7392723](https://doi.org/10.1109/IECON.2015.7392723)

Publication date:

2015

Document Version

Publisher's PDF, also known as Version of record

[Link to publication from Aalborg University](#)

Citation for published version (APA):

Bede, L., Gohil, G., Ciobotaru, M., Kerekes, T., Teodorescu, R., & Agelidis, V. G. (2015). Circulating current controller for parallel interleaved converters using PR controllers. In Proceedings of the 41th Annual Conference of IEEE Industrial Electronics Society, IECON 2015 (pp. 003997-004002). IEEE. DOI: 10.1109/IECON.2015.7392723

General rights

Copyright and moral rights for the publications made accessible in the public portal are retained by the authors and/or other copyright owners and it is a condition of accessing publications that users recognise and abide by the legal requirements associated with these rights.

- ? Users may download and print one copy of any publication from the public portal for the purpose of private study or research.
- ? You may not further distribute the material or use it for any profit-making activity or commercial gain
- ? You may freely distribute the URL identifying the publication in the public portal ?

Take down policy

If you believe that this document breaches copyright please contact us at vbn@aub.aau.dk providing details, and we will remove access to the work immediately and investigate your claim.

Circulating Current Controller for Parallel Interleaved converters using PR Controllers

Lorand Bede¹, Ghanshyamsinh Gohil¹, Mihai Ciobotaru², Tamas Kerekes¹, Remus Teodorescu¹, Vassilios G Agelidis²

Department of Energy Technology¹

Aalborg University

Aalborg, Denmark

lbe@et.aau.dk

Australian Energy Research Institute²

University of New South Wales

Sydney, Australia

Abstract— To cope with power from large-scale renewable systems, more and more power electronic converters are used in parallel. Typically, carrier interleaving is used, thus leading to a decrease in filtering requirements. However, this causes additional circulating current to flow between the modules of the converter. The modules of the parallel converters are Voltage Source Converters (VSC). Usually, a coupled inductor (CI) is used to suppress the circulating current. However, the CI can be sensitive to the low order harmonic content of the circulating current which can appear owing to parameter mismatches between the converters. If the value of the low frequency circulating current is too high, this can saturate the CI. In order to ensure stable operation of the converter, this article presents a circulating current control based on the Proportional Resonant (PR) controller, which reduces the value of the low frequency circulating current. Furthermore, a specially designed sampling method is also presented, which ensures that only the fundamental component of the circulating current is fed to the circulating current controller.

Keywords—Parallel interleaved converters, Circulating current control Grid connected, Coupled inductor,

I. INTRODUCTION

In recent years the power rating of the renewable energy sources has increased significantly. In order to keep the grid stable more and more stringent grid codes are to be introduced. One of the most stringent ones is the German BDEW standard, which specifies the current harmonic injection limit up to the 180th harmonic [1].

In order to meet these grid requirements the electrical energy produced by these converters has to be processed by a power electronic converter. The most commonly used converter, in these applications, is the two level Voltage Source Converter (VSC) [2]. In the parallel interleaved system the modules of the converter are VSCs. Due to the limited power handling capability of these converters they are often connected in parallel [3].

Studies proved that by using the carrier interleaving technique the resultant current can be improved compared to the non-interleaved ones. Carrier interleaving cancels the first

order switching harmonic and can reduce the value of the upper harmonics and the filtering requirements [4]. On the other hand, the carrier interleaving causes additional circulating current to flow between the converter modules. The circulating current is a result of the difference in the pole voltages (measured between the phase and the fictitious O point of the dc-link). Due to this difference in the phase voltages the positive and negative terminals of the dc-link will be short circuited through the filter inductors [5]. The suppression of the circulating current can be achieved by multiple solutions. One solution is to insert an isolation transformer at the output of each converter module, hence cutting the path of the circulating current [6]. This solution is the most costly one since bulky transformers are required. Another solution is presented in [7], where a common mode (CM) filter is inserted at the output of every converter. In [8-12] the authors use a coupled inductor (CI) for suppressing the circulating current. In this paper the CI will be used due to its good performance against the circulating current. The drawback of this solution is that the current between the modules has to be shared equally. Failing to do so, the core of the CI may saturate because of the low frequency circulating current that appears between the modules.

Improper current sharing can be due to differences in the control signals applied to the different converters, or owing to parameter mismatches and parasitic impedances on the path of the converter current. The effects of these mismatches have to be eliminated in order to ensure proper current sharing. This can be achieved by multiple solutions.

In [13], the authors control the circulating current by controlling the difference in the Pulse Width Modulated (PWM) signals. While in [8], the authors ensure current sharing by calculating an average current for a phase, based on this information they change the control signals for the phases individually. Fen *et al.* [14] and [15] control the common mode current between the modules of the parallel VSC, and not the circulating current for every phase. A dead beat circulating current controller is used in [16]. In this case the authors control the circulating current by modifying the common mode voltages applied to the converters. The concept of circulating

impedance is introduced in [15]. The current sharing is ensured by controlling a virtual impedance between the modules of the parallel connected VSC.

All the previous models, compensate for the instantaneous circulating currents or they try to maintain an average current. However, there is no special focus on the low frequency circulating current.

In this article the authors propose a Proportional Resonant (PR) controller for controlling the low frequency circulating current. The benefit of this solution is the high gain of the PR controller at the resonance frequency [17]. Moreover, a sampling method will be explained which, ensures that the compensation is done only for the low order components.

The paper is organized as follows: in section II the model of the CI is presented along with the circulating current modeling. The next section presents the controller used for circulating current control. The simulation and experimental results are shown in section IV, while the conclusion in section V.

II. CIRCULATING CURRENT

A. Setup description

The setup consisting of two parallel connected VSCs, which are connected to the grid using a step-up transformer, is presented in Fig. 1. The carrier interleaving technique is used to cancel the effect of the first order switching harmonic in the resultant current and to be able to reduce the size of the grid current filters [18]. On the other hand, the carrier interleaving causes additional circulating current to flow between the two VSCs. To effectively suppress this circulating current a CI is introduced between the same phases of the two interleaved VSCs.

B. Coupled inductor model

In Fig. 2 the scheme of the CI is presented, where R_{x1} and R_{x2} , represent the winding resistances of the two phases. Due to interleaving, there will be instances when the upper switch of VSC1, for phase A, will be clamped to the positive dc link terminal, and at the same time the bottom switch of VSC2 will be connected to the negative dc link terminal.

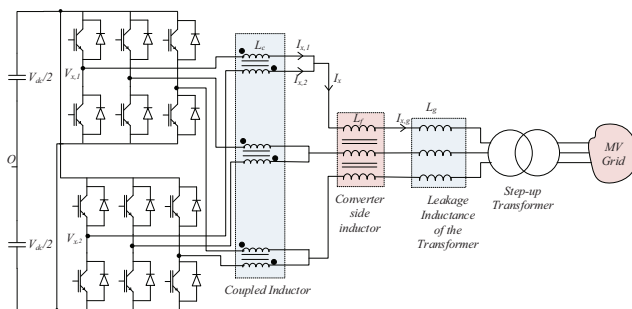

Fig. 1 Topology of two grid connected VSCs connected in parallel using coupled inductors as circulating current filters

Therefore, the positive and negative terminals of the dc link will be short circuited through the CI. Hence, the purpose of the CI is to offer a high impedance on the path of this current.

Typically, the CI is designed to act on the switching frequency component of the converter current and on its odd multiples. If the current sharing between the converter modules is not equal, an additional circulating current component appears.

The current from both converters produce a magnetic flux in the coupled inductor. Due to the physical arrangement of the windings, the flux produced by I_{x1} will have an opposite direction compared to the flux produced by I_{x2} . Thus, the fundamental component of the two currents will be cancelled.

The circulating current can be modelled as follows [10]:

$$\begin{aligned} I_{x,1} &= I_{x1} + I_{x,c} \\ I_{x,2} &= I_{x2} - I_{x,c} \end{aligned} \quad (1)$$

where, I_{x1} and I_{x2} represent the fundamental current component for phase x ($x = [A,B,C]$) of VSC1 and VSC2, respectively. $I_{x,1}$ and $I_{x,2}$ are the currents measured at the output of VSC1 and VSC2. The total current (I_x), which in this case is the grid current ($I_{x,g}$), is expressed as

$$I_x = 2I_{x1} \quad (2)$$

From (1) the circulating current $I_{x,c}$ is derived as

$$I_{x,c} = \frac{I_{x,1} - I_{x,2}}{2} \quad (3)$$

Furthermore, if there is a mismatch between the fundamental component of the phase current ($I_{x,1}$, $I_{x,2}$) this will generate a low frequency (50 Hz) current to flow between the two VSCs. This current will result in a low frequency magnetic flux, which will be added on the top of the flux generated by the interleaving. Because the CI is designed only for high order harmonics, having a low order harmonics may saturate the CI, and eventually trip the converter. To overcome this issue, it has to be assured that the fundamental components of both VSCs currents ($I_{x,1}$, $I_{x,2}$) are equal all the time.

The fundamental components of the converter currents can be different due to multiple reasons, such as:

- Difference in the on-state voltage drop of the switching devices
- Mismatches in the parameters of the CI inductor due to manufacturing
- Mismatches in the turn on and turn off times of the employed switching devices
- Difference in the cable parameters which are used to interconnect the VSCs
- Difference in the parameters of the current sensors (such as: calibration, tolerance etc.)

All of these mismatches maybe assumed as a difference in the resistances which are inserted in the path of the output current of each of the VSCs. The value of the resultant resistance mismatch has been purposely exaggerated in this paper in order to highlight the performance of the proposed PR controller.

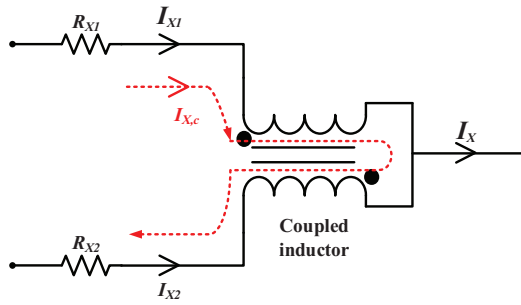

Fig. 2 Model of the Coupled Inductor including the parasitic resistances

III. CIRCULATING CURRENT CONTROLLER

A. Grid Current Controller description

In the configuration, depicted by Fig. 1, the grid current ($I_{x,g}$) is controlled, and the same modulating signals are applied to both converters, but the carriers are interleaved. Therefore, the fundamental component of the grid current will be equally shared between the converter modules. However, if there is difference between the converter modules, the current sharing will not be ideal, hence a low frequency circulating current will appear between the two converter modules.

To control the grid current a Proportional Resonant (PR) controller is used, since it offers high gain at the fundamental frequency. The benefits of using PR controllers for controlling the grid current has been presented in [17]. The transfer function of the PR controller is presented below

$$G_{PR} = Kp + Ki \frac{s}{s^2 + \omega_0^2} \quad (4)$$

Where, Kp is the proportional gain, Ki is the integral gain, and ω_0 is the angular speed of the utility grid.

The reference voltages, which are calculated by the controller, are used as an input for the modulators of the two VSCs. Every VSC has its' own modulator, since the PWM signals have to be phase shifted by the specified interleaving angle.

B. Circulating Current Controller

To control the circulating current at the fundamental frequency, an additional PR controller is used. The reason behind it is that if there is a mismatch in the fundamental values of the two currents, that one will be translated into a circulating current having mostly fundamental frequency. On the other hand, the phase of the circulating current can be only determined by using single-phase Phased-Locked-Loop (PLL). This will further complicate the control structure, since all circulating currents will require a PLL.

Since, the modulating signal is applied to both converters the modulating signal has to be modified, in order to be able to control the circulating current. The output signal of the circulating current controller will be added to only one of the modulating signals of the VSCs. The circulating current is

present between the phases of two converter modules, therefore it is sufficient to modify the modulating signal of only one of the converters.

In Fig. 3 the scheme of the circulating current controller is presented. The V_{A_ref} signal is the reference signal for phase A which has been synthesized by the grid current controller. The output of the circulating current controller is subtracted from this value before the signal goes to the modulator of VSC2. On the other hand, the V_{A_ref} for the other modulator is not changed.

When controlling the grid current the double update technique is used, in order to achieve higher bandwidth. Specifically, that the grid current is sampled in the beginning and in the middle of the switching period. Hence, the reference voltage will be calculated and updated twice during one switching interval. In the case of the circulating current controller, the circulating current is sampled only once during a switching interval.

As stated previously, the circulating current has two major components: a high frequency one, which is due to the switching, and a low frequency one which occurs because of the difference of the fundamental currents of the two VSCs. If the same sampling frequency would have been used ($2 \cdot f_{sw}$) as per the grid current controller, then according to the Nyquist criteria, the sampled signal will have components from both circulating current components. Since only the low frequency one can be controlled, it is essential that only this component is used for control. One solution can be to use filters to filter out this component. But by using filters the complexity of the controller is increased, and the performance is reduced because the filter would introduce delay in the system. To overcome these problems, the circulating current is sampled only once during a switching period. Doing so the switching frequency component will not be visible in the sampled value, only the low frequency one. The drawback of the solution is that the bandwidth of the controller is reduced. However, since the used controller is a PR one, and this is tuned for the fundamental frequency, by reducing the samples the control bandwidth is not affected.

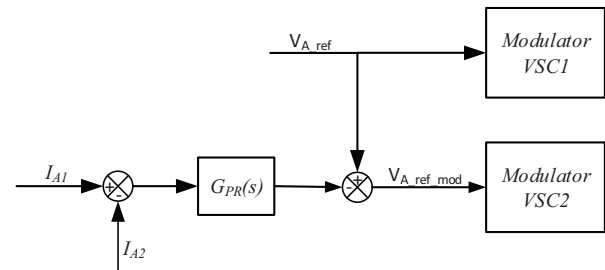

Fig. 3 Structure of the circulating current controller

IV. SIMULATION AND EXPERIMENTAL RESULTS

A. Simulation Results

To verify the performance of the circulating current controller a simulation model using Matlab/Simulink and Plecs

has been used. In TABLE I the parameters used for the simulation and experimental studies are presented.

The circulating current and the magnetic flux for phase A when no circulating current controller is used, are presented in Fig. 4. The magnetic flux produced by the difference of the fundamental current reaches the level of 1.5 T for the CI used in the simulation. On the other hand, when the circulating current controller is enabled (Fig. 5), the magnetic flux value is decreased significantly (from 2.8 T to ~ 0.9 T). Moreover, the low frequency component is also suppressed.

TABLE I SIMULATION AND EXPERIMENTAL PARAMETERS

Parameter	Value
Inductance of the CI (L_c)	0.051 H
Switching/Sampling frequency(f_{sw})	2.55kHz
Interleaving angle	180°
Power	10 kVA
Nominal current	14A rms
Grid voltage	400 Vrms(l-l)
Grid frequency	50 Hz
Modulation method	Space Vector Modulation

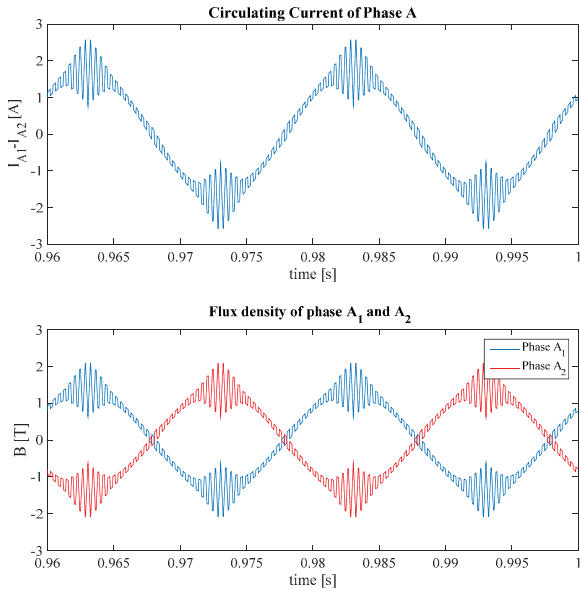

Fig. 4 Without circulating current controller Upper figure: Circulating current of phase A; bottom figure: red- magnetic flux produced by the current of phase A of VSC1; blue:-magnetic flux produced by the current of phase A of VSC2

B. Experimental results

An experimental setup, consisting of two VSCs connected in parallel has been built with a total power of 10 kVA, and the performance of the controller has been investigated. To emphasize the mismatch in the parameters of the two VSCs an

additional resistance has been included in the experimental setup at the output of phase A of VSC1. The control logic was implemented using a TMS320F28346 microcontroller unit, while a California Instruments grid emulator was used.

The measurements were carried out at nominal load. Unfortunately, since the magnetic flux produced by the current of VSC1 and VSC2 cannot be measured directly, but the flux in the CI is the replica of the current hence only the measured currents are presented. In Fig. 6, the experimental results are shown for the case when no circulating current controller has been used. This figure depicts the individual currents of phase A of VSC1 and VSC2, the grid current and the circulating current for the same phase. It can be seen that the circulating current has also low frequency component along with the high frequency one.

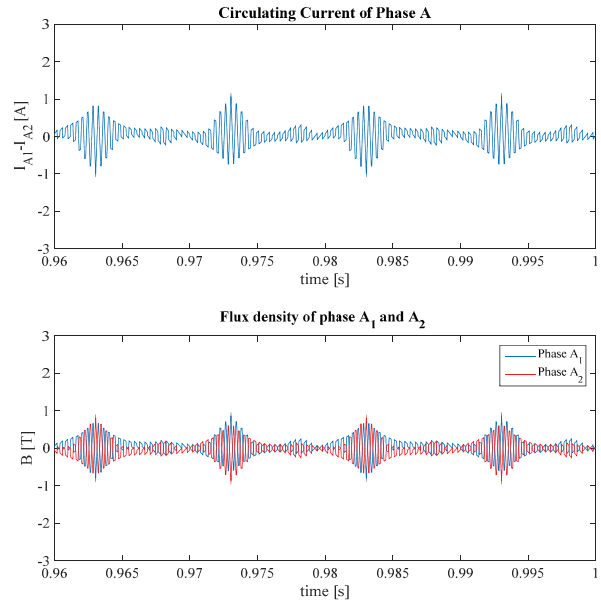

Fig. 5 With circulating current controller Upper figure: Circulating current of phase A; bottom figure: red- magnetic flux produced by the current of phase A of VSC1; blue:-magnetic flux produced by the current of phase A of VSC2

The experimental results when the circulating current controller is employed are presented by Fig. 7. This measurement shows the same quantities as the previous figure, however, in this case the low frequency component of the circulating current has been reduced significantly.

The flux density in the CI should be restricted below the saturation flux density. The peak value of the flux density is proportional to the peak value of the circulating current and effectiveness of the controller has been demonstrated by comparing the peak value of the circulating current in both cases. When the circulating current controller has been used this value was decreased by ~ 2 A (from 4.63A to 2.06 A), proving that the circulating current controller reduced the peak-to-peak value of the circulating current, thus resulting in smaller magnetic flux for the CI. Furthermore, the circulating current

shape and magnitude from the measurements are similar with the results from the simulation.

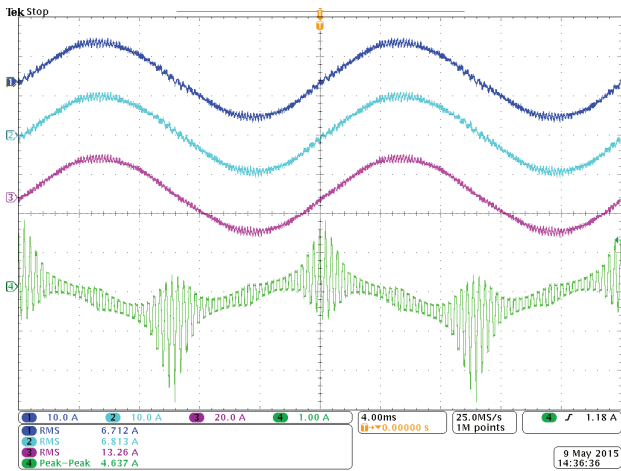

Fig. 6 Experimental results without circulating current control: CH1(blue)-Phase A current of VSC1; CH2(light blue)-Phase A current of VSC2; CH3(purple)- total current for Phase A; CH4(green)-circulating current for Phase A between VSC1 and VSC2;

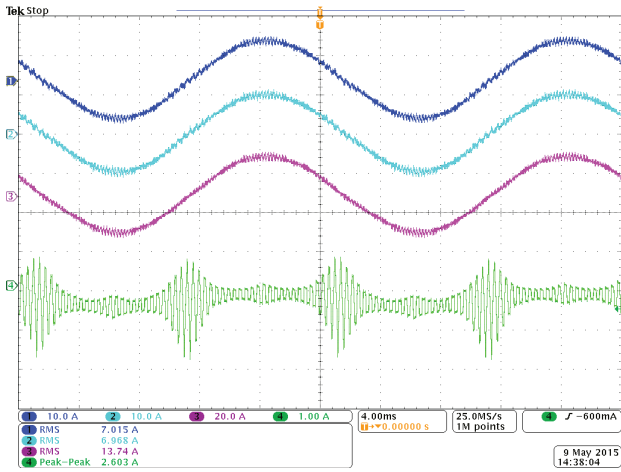

Fig. 7 Experimental results with circulating current control: CH1(blue)-Phase A current of VSC1; CH2(light blue)-Phase A current of VSC2; CH3(purple)- total current for Phase A; CH4(green)-circulating current for Phase A between VSC1 and VSC2;

The circulating current for the controlled and uncontrolled case is shown by Fig. 8. At the trigger point of the figure, the circulating current controller is turned off. It can be observed that in both cases the circulating current has some low frequency harmonics. This is present due to the mismatch in the current sensors.

V. CONCLUSION

This paper has presented a control method in *abc* natural frame to address the circulating current in grid connected

parallel interleaved VSCs. The use of a PR controller eliminates the need of a PLL, thus significantly simplifying the control structure. Moreover, by using this method, any other conventional grid current controllers can be used, since the circulating current controller is fully decoupled from the grid current controller.

A sampling method, which eliminates the switching frequency harmonic from the circulating current has also been presented. Doing so, there is no need for additional filtering, which would introduce additional delays in the system. Therefore, a stable operation for the PR controller can be achieved.

To prove the effectiveness of the proposed controller, both simulation and experimental results are presented. It can be concluded that the proposed controller effectively suppresses the circulating current, ensuring that the CI is not saturated. Furthermore, the design margin for the saturation of the CI can be decreased, hence the size of it can be reduced.

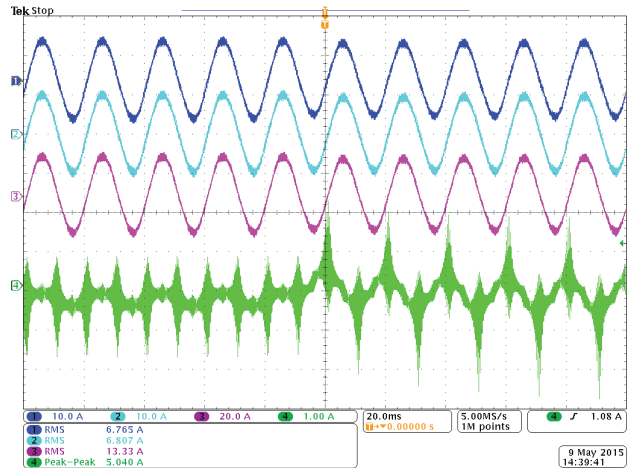

Fig. 8 Experimental results with circulating current control when the circulating current controller is turned off in the middle of the period: CH1(blue)-Phase A current of VSC1; CH2(light blue)-Phase A current of VSC2; CH3(purple)- total current for Phase A; CH4(green)-circulating current for Phase A between VSC1 and VSC2;

REFERENCES

- [1] B. B. d. Energieund and Wasserwirtschaft e.V., "Technical guideline: Generating plants connected to the medium-voltage network," ed, 2008.
- [2] F. Blaabjerg, M. Liserre, and M. Ke, "Power Electronics Converters for Wind Turbine Systems," *Industry Applications, IEEE Transactions on*, vol. 48, pp. 708-719, 2012.
- [3] B. Andresen and J. Birk, "A high power density converter system for the Gamesa G10x 4,5 MW wind turbine," in *Power Electronics and Applications, 2007 European Conference on*, 2007, pp. 1-8.
- [4] G. Gohil, L. Bede, R. Teodorescu, T. Kerekes, and F. Blaabjerg, "Line Filter Design of Parallel Interleaved VSCs for High Power Wind Energy Conversion

- System," *Power Electronics, IEEE Transactions on*, vol. PP, pp. 1-1, 2015.
- [5] J. S. S. Prasad and G. Narayanan, "Minimization of Grid Current Distortion in Parallel-Connected Converters Through Carrier Interleaving," *Industrial Electronics, IEEE Transactions on*, vol. 61, pp. 76-91, 2014.
- [6] J. W. Dixon and B. T. Ooi, "Series and parallel operation of hysteresis current-controlled PWM rectifiers," *Industry Applications, IEEE Transactions on*, vol. 25, pp. 644-651, 1989.
- [7] L. Asiminoaei, E. Aeloiza, P. N. Enjeti, and F. Blaabjerg, "Shunt Active-Power-Filter Topology Based on Parallel Interleaved Inverters," *Industrial Electronics, IEEE Transactions on*, vol. 55, pp. 1175-1189, 2008.
- [8] G. J. Capella, J. Pou, S. Ceballos, J. Zaragoza, and V. G. Agelidis, "Current-Balancing Technique for Interleaved Voltage Source Inverters With Magnetically Coupled Legs Connected in Parallel," *Industrial Electronics, IEEE Transactions on*, vol. 62, pp. 1335-1344, 2015.
- [9] S. Dongsul, L. Jong-Pil, L. Kyoung-Jun, K. Tae-Jin, Y. Dong-Wook, P. Fang Zheng, *et al.*, "1.5MVA grid-connected interleaved inverters using coupled inductors for wind power generation system," in *Energy Conversion Congress and Exposition (ECCE), 2013 IEEE*, 2013, pp. 4689-4696.
- [10] G. Gohil, L. Bede, R. Maheshwari, R. Teodorescu, T. Kerekes, and F. Blaabjerg, "Parallel interleaved VSCs: Influence of the PWM scheme on the design of the coupled inductor," in *Industrial Electronics Society, IECON 2014 - 40th Annual Conference of the IEEE*, 2014, pp. 1693-1699.
- [11] D. Shin, K.-J. Lee, H.-J. Kim, J.-P. Lee, T.-J. Kim, and D.-W. Yoo, "Coupled inductors for parallel operation of interleaved three-phase voltage source grid-connected inverters," in *Applied Power Electronics Conference and Exposition (APEC), 2013 Twenty-Eighth Annual IEEE*, 2013, pp. 2235-2239.
- [12] D. Shin, J. Lee, D. Yoo, and H. Kim, "Stability Improvement of Interleaved Voltage Source Inverters Employing Coupled Inductors for Grid-Connected Applications," *Industrial Electronics, IEEE Transactions on*, vol. PP, pp. 1-1, 2015.
- [13] J. Suo, Y. Yang, and C. Qi, "Control of circulating current for direct parallel grid-connected inverters in photovoltaic power generation," in *Mechatronics and Automation, 2009. ICMA 2009. International Conference on*, 2009, pp. 3805-3810.
- [14] T. Fen, J. Xinmin, T. Yibin, L. Jingdou, Z. Fei, and M. Lin, "Parallel interleaved grid-connected converters in MW-level wind power generation," in *Electric Machines and Drives Conference, 2009. IEMDC '09. IEEE International*, 2009, pp. 789-796.
- [15] Y. Mi, K. Yong, Z. Yu, Y. Ming, D. Shanxu, S. Hongtao, *et al.*, "A Novel Decoupled Current-Sharing Scheme Based on Circulating-Impedance in Parallel multi-Inverter System," in *Industrial Electronics Society, 2007. IECON 2007. 33rd Annual Conference of the IEEE*, 2007, pp. 1668-1672.
- [16] X. Huagen, L. An, B. Lisha, T. Chunming, Z. Juan, and L. Qing, "A deadbeat control method for circulating current between parallel-connected inverters," in *Future Energy Electronics Conference (IFEEEC), 2013 1st International*, 2013, pp. 806-811.
- [17] J. G. Hwang, P. W. Lehn, and M. Winkelnkemper, "A Generalized Class of Stationary Frame-Current Controllers for Grid-Connected AC-DC Converters," *Power Delivery, IEEE Transactions on*, vol. 25, pp. 2742-2751, 2010.
- [18] G. Gohil, L. Bede, R. Teodorescu, T. Kerekes, and F. Blaabjerg, "Design of the trap filter for the high power converters with parallel interleaved VSCs," in *Industrial Electronics Society, IECON 2014 - 40th Annual Conference of the IEEE*, 2014, pp. 2030-2036.