



**AALBORG UNIVERSITY**  
DENMARK

**Aalborg Universitet**

## **Advanced grid integration of renewables enabled by power electronics technology**

Blaabjerg, Frede; Yang, Yongheng; Ma, Ke; Wang, Xiongfei

*Published in:*

Nachhaltige Energieversorgung und Integration von Speichern

*DOI (link to publication from Publisher):*

[10.1007/978-3-658-10958-5](https://doi.org/10.1007/978-3-658-10958-5)

*Publication date:*

2015

*Document Version*

Early version, also known as pre-print

[Link to publication from Aalborg University](#)

*Citation for published version (APA):*

Blaabjerg, F., Yang, Y., Ma, K., & Wang, X. (2015). Advanced grid integration of renewables enabled by power electronics technology. In D. Schulz (Ed.), *Nachhaltige Energieversorgung und Integration von Speichern: Tagungsband zur NEIS 2015* (pp. 3-9). Springer. DOI: 10.1007/978-3-658-10958-5

### **General rights**

Copyright and moral rights for the publications made accessible in the public portal are retained by the authors and/or other copyright owners and it is a condition of accessing publications that users recognise and abide by the legal requirements associated with these rights.

- ? Users may download and print one copy of any publication from the public portal for the purpose of private study or research.
- ? You may not further distribute the material or use it for any profit-making activity or commercial gain
- ? You may freely distribute the URL identifying the publication in the public portal ?

### **Take down policy**

If you believe that this document breaches copyright please contact us at [vbn@aub.aau.dk](mailto:vbn@aub.aau.dk) providing details, and we will remove access to the work immediately and investigate your claim.

# Advanced Grid Integration of Renewables Enabled by Power Electronics Technology

Frede Blaabjerg, Yongheng Yang, Ke Ma, Xiongfei Wang

Department of Energy Technology, Aalborg University  
Pontoppidanstraede 101, Aalborg DK-9220, Denmark  
[fbl@et.aau.dk](mailto:fbl@et.aau.dk), [yoy@et.aau.dk](mailto:yoy@et.aau.dk), [kema@et.aau.dk](mailto:kema@et.aau.dk), [xwa@et.aau.dk](mailto:xwa@et.aau.dk)

## Abstract

In the past decades, many countries (e.g., Germany and Denmark) have experienced a significant change in their energy structures – from fossil-based resources to clean renewables. The scenario of highly penetrated renewables is going to be further enhanced in the future mixed energy paradigms. This requires that the production, distribution and use of the energy should be as technological efficient as possible and incentives to save energy at the end-user should also be strengthened. In order to realize the transition smoothly and effectively, energy conversion systems, currently based on power electronics technology, will again play an essential role in advancing the grid integration of renewables. In view of this issue, some of the most emerging renewable energies, e.g., wind energy and photovoltaic, which by means of power electronics are changing character as a major part in the electricity generation, are explored. Issues like demands to renewables, power converter technologies, control of the systems, and advanced grid integration are covered.

## 1 Introduction

Demands of reliable and environmental-friendly electricity generation from Renewable Energy Systems (RESs) have been the main driving force for the RES development [1]-[5]. Consequently, great efforts have been made by many countries (e.g., Germany, Spain, and Denmark) to alter their energy paradigms with more installations of renewables such as wind power, PhotoVoltaic (PV) power, hydropower, and biomass power. Among various renewable power systems, Wind Turbine System (WTS) and PV system technologies are still the most promising technologies, accounting for a large portion of renewable energy generation [4]-[14], and will expand more. However, the increasing adoption of RESs poses two major challenges. One is the energy structure transition – from the conventional and fossil-based energy to renewables. The other one is the wide-scale use of power electronics in the power generation, the grid integration, the power transmission/distribution and the end-user application.

On the other hand, the power electronics technology has become the enabling technology to advance the grid integration of various renewables. Hence, the power electronics systems should be highly efficient and exceedingly reliable. Basically, it should be able to transfer the renewable energies to the power grid. More important, it should be capable to exhibit advanced ancillary functions (e.g., Low Voltage Ride-Through, LVRT, grid support with reactive power injection). A wide-scale adoption of power electronics technology makes those completely weather-dependent energies more controllable, but increasingly intricate. Underpinned by intelligent control strategies, the

power electronics technology can fulfill the requirements imposed by the distribution/transmission system operators as well as specific demands from the end-users, especially when more advanced power devices and more accurate knowledge of the mission profiles are available.

In this paper, the power electronics technology, enabling a clean and reliable power conversion from renewables, is discussed. In § II, the basic demands to RESs are presented, followed by the WTS and PV technologies including main power converter topologies. Then, typical control strategies for PV systems and wind turbines are presented considering the grid demands. Due to the increasing complexity of the future power systems integrated with a large amount of RESs, in § III, the advanced grid integration enabled by the power electronics technology is summarized. Finally, the conclusions and perspectives are given for the two main renewable energies.

## 2 Demands to Renewables

Fig. 1 demonstrates the architecture of a typical RES based power system, where the power electronics unit is the core of the system. Increasing penetration of RESs results in rigorous demands to the key part of the entire system, i.e., the power electronics. As shown in Fig. 1, the tasks of a power electronics based RES are as varied as they are demanded by the local operators or the end-users [4]-[6]. A very basic demand is to transfer the energy to the grid according to the renewable energy characteristics. Other specific demands to the RESs can be summarized as: a) reliable/secure power supply, b) high efficiency, low cost, small volume, and effective protection, c) control of active and reactive power injected into the grid, d) dynamic grid support (ride-through operation), and e) system monitoring and communication.

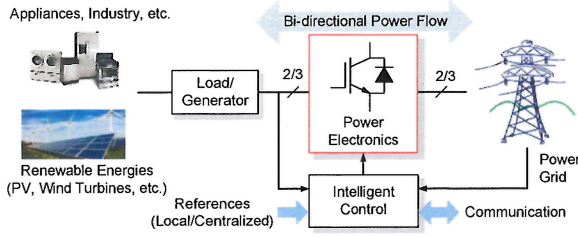

Fig. 1. Power electronics technologies and intelligent control techniques enabled renewable energy system.

## 2.1 General Requirements for Renewables

### 2.1.1 Demands to Wind Power Conversion Systems

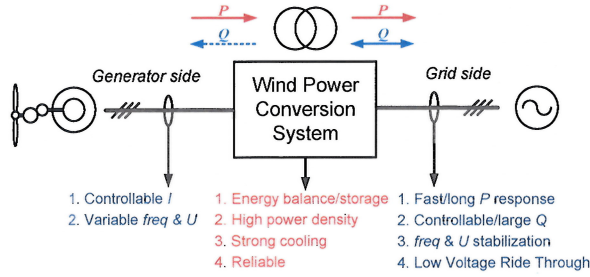

Fig. 2. Demands to wind turbine power systems.

Fig. 2 shows the demands to wind turbine power systems at different levels. Specifically, for the generator side, the current flowing in the generator rotor or stator should be regulated to control the electromagnetic torque, not only for maximizing the extracted power from the wind turbines, but also for the energy balancing in case of dynamics due to inertia mismatch between mechanical and electrical power. For the grid side, the converter must emulate the behaviors of conventional power plants regardless of the wind speed. This means it should help to maintain the frequency as well as voltage amplitude of the grid, and also withstand the grid faults or even contribute the faults recovery [4], [6], [11].

Due to the relative large power capacity, the failures of wind power conversion system will strongly impact the grid stability and result in high repairing cost; thereby the reliability performance is especially emphasized [14]-[17]. Also because of high power capacity, the voltage level of generator may need to be boosted up to facilitate the power transmission, and thus transformers are normally required. Furthermore, because of the limited space in the nacelle or tower of the WTS, the power density and cooling ability are crucial in wind power systems. Finally, due to the power mismatch between the wind turbine and the grid, and energy storage, balancing is an important issue and may result in extra cost of the system.

### 2.1.2 Demands to PV Power Conversion Systems

Due to the fast development, even tougher requirements have been released for PV systems [18]-[20]. These demands can be generally categorized into the three parts as shown in Fig. 3. However, the power capacity of a PV system is not as large as that of an individual WTS.

Moreover, the power inertia of PV output is compatible with the grid behavior, and therefore, the demands to PV systems are less stringent than those to WTSs.

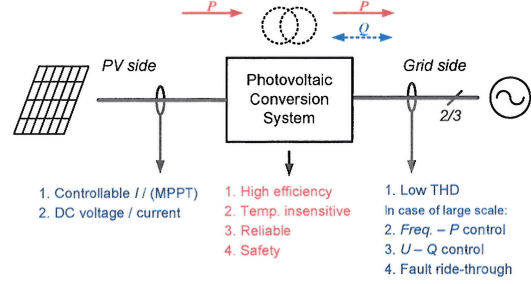

Fig. 3. Demands to PV power conversion systems.

For the PV side, the current or voltage of PV panels should be controlled to extract the energy. In view of this, a DC-DC converter is commonly used in PV systems to flexibly track the maximum power, where the DC voltage should be maintained as a desirable value for the inverter. For the grid side, normally the Total Harmonic Distortion (THD) of the output current has to be restrained at a lower level (e.g., 5%) [4], [18]. While for large PV power systems with higher power ratings (e.g., hundreds kW), the grid side also demands the PV inverter to stabilize the grid voltage by providing ancillary services. In response to grid faults, the PV inverters have to ride-through voltage faults, when a higher PV penetration level comes into reality [18]-[29], as what have been required for WTSs.

Additionally, for the PV technology, the power capacity per generating unit is relative low but the cost of energy is relative high. Hence, there are very strong demands for high efficiency in PV systems. On the other hand, transformerless PV inverters have gained increasing popularity in the European market (e.g., Germany and Spain) [4], [30]-[32] in order to further extend the efficiency. However, in this case, the galvanic safety becomes a more crucial issue. Reduction of the potential leakage current is generally required in such applications. Furthermore, similar to the wind power conversion systems, reliability is also important for power electronics based PV systems, and motivated by extending the total energy production and reducing the cost [18], [33], [34]. Finally, because of exposure or smaller housing chamber, the PV converter system must be more temperature insensitive, which is also beneficial to the reliability performance.

## 2.2 Grid Integration Requirements

Fluctuation and unpredictability are the characteristics of renewable power, which is not preferable for grid operation. Hence, the grid integration focuses on the RES connection point in order to alleviate the potential harmfulness to the grid. In that case, the RESs should not only be passively and simply injecting available power to the grid, but also behave like an active generation unit, which can manage the power exchange with the grid according to demands, and provide frequency/voltage support for the power grid, as aforementioned.

Many grid integrated systems are demanded to control the active power at the Point-of-Common-Coupling (PCC). Normally, the active power has to be regulated based on the grid frequency. For example, in the Danish grid code, the active power should be decreased when the frequency rises above 48.7 Hz or 50.15 Hz depending on the power reserving strategy [35]. Similarly, the reactive power provided by the RESs has to be regulated in a certain range, as exemplified in Fig. 4, which gives a range of the reactive power delivered by the WTSs in respect to the active power [36]. Moreover, the Transmission System Operator (TSO) will normally specify the reactive power range in order to maintain the grid voltage levels. Notably, this reactive power control should be realized slowly under the time constant of minutes in steady state operation [37].

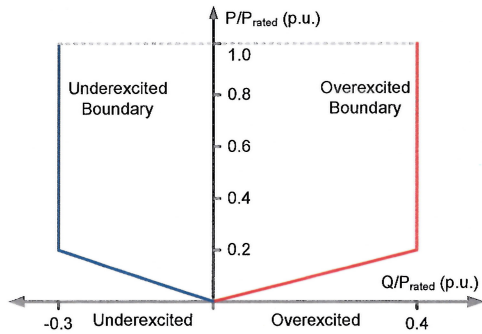

**Fig. 4.** Reactive power ranges for a wind farm specified in the German grid codes [36].

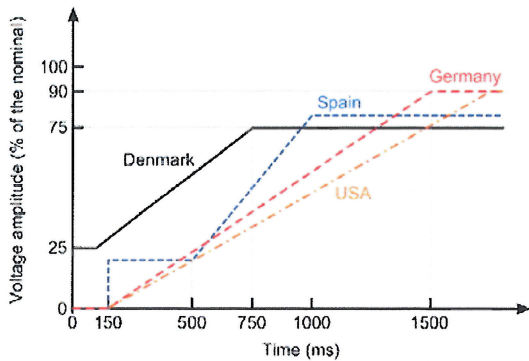

**Fig. 5.** Voltage profiles for the low voltage ride-through (LVRT) capability defined by different countries [37].

Besides the normal operation, the TSOs in different countries have released grid support requirements for the generating units under grid faults. As shown in Fig. 5 [36], [37], in which voltage profiles are defined for wind turbine systems in response to grid faults. Additionally, it has been a demand that the RES system should also provide reactive power (up to 100% current capacity) to contribute to the voltage recovery. The requirements for more grid supports by the grid-connected renewables on one hand have increased the cost per produced kWh, but on the other hand made them more suitable to be largely utilized and integrated into the grid. It can be predicted that the stricter grid codes in the future will keep challenging the renewable systems and pushing forward the power electronic technologies.

### 3 Power Electronics Technology – advancing the grid integration

The design and operation of power electronics converters for both wind turbine and PV systems strongly rely on the grid requirements and the energy demand. It can be seen from the evolution of wind turbine power converters, which has changed from non-power-electronics-based topologies to full-scale power converters with increasing power ratings of individual wind turbine [4], [10]-[12]. As the demand of higher power ratings and efficiency increases for PV systems, the PV power converters also had experienced a clear change, and they are mostly transformerless nowadays [4], [8], [9], [31].

#### 3.1 Power Converter Technology

##### 3.1.1 Power Converters for WTSs

Depending on the types of generator, power electronics, speed controllability, and the way in which the aerodynamic power is limited, the wind turbine designs can generally be categorized into several concepts. In these applications, the power converters play different roles and have various power ratings. Up till now, the configuration of Doubly Fed Induction Generator (DFIG) with partial-scale power converters still dominates on the market, as shown in Fig. 6(a). In very near future, the configuration with Synchronous Generator (SG) with full-scale power converters is expected to take over the WTS market [10], [14], [17], as it is shown in Fig. 6(b). Each of the WTS concepts has its suitable converter topologies and some of them are illustrated in the following.

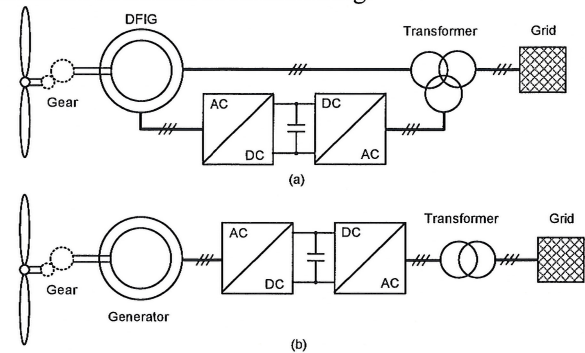

**Fig. 6.** Dominant WTS configurations: a) variable speed wind turbine with partial-scale power converter and a doubly fed induction generator and (b) variable speed wind turbine with full-scale power converter and an asynchronous/synchronous generator.

##### A. Two-level power converters

Due to simplicity, the two-Level Voltage Source Converter (2L-VSC) is the most common solution so far in the DFIG WTSs, since the power rating requirement is limited. In practice, two 2L-VSCs are configured in a Back-To-Back (BTB) way, as shown in Fig. 7. One advantage of the 2L-BTB solution lies in the full power controllability with a relatively simple structure and few components, which in return contribute to a well-proven, robust, and reliable performance as well as lower cost.

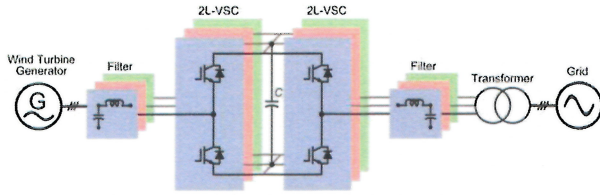

Fig. 8. 2L-VSC BTB voltage source converter for WTSs.

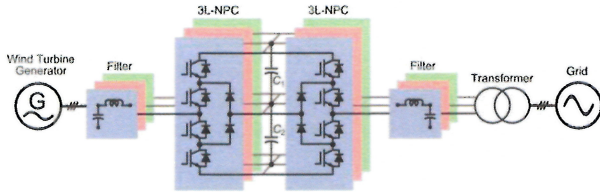

Fig. 9. 3L-NPC BTB topology for WTSs.

### B. Multi-level power converters

With the abilities to achieve a higher voltage and a higher power level, multi-level power converters are getting more popularity in WTSs [13], [14]. The three-Level Neutral Point Clamped (3L-NPC) topology is one of the multi-level topologies on the market, as shown in Fig. 8. The 3L-NPC BTB solution achieves one more output voltage levels and less  $dv/dt$  stresses in contrast to the 2L-BTB, and thus it is possible to convert the power at MV level with lower currents, less paralleled devices, and smaller filter size. The main drawback of the 3L-NPC BTB is the mid-point voltage fluctuation of the DC-bus, which has been extensively investigated [14], [38].

In order to handle the fast growth in the power capacity, multi-cell converter configurations (i.e. parallel and/or series connection of converter units) are also being developed and becoming widely commercialized in the wind turbine industry [39].

### 3.1.2 Power Converters for PV Systems

For PV systems, a general classification of grid-connected PV inverters is shown in Fig. 7 [8], [31]. A common central inverter can be used in a PV plant larger than tens kWp with higher efficiency and lower cost [8]. Compared to central inverters, the string inverter can achieve MPPT separately, leading to better total energy yield. The module inverter acts on a single PV panel with a single MPPT. As shown in Fig. 9, another PV technology is an intermediate solution between the string inverter and the module inverter, being multi-string inverter. This configuration is flexible with a high overall efficiency because each PV string is controlled separately.

Additionally, the PV systems are still dominant in residential applications with much lower power ratings (e.g. several kW). Thus, single-phase topologies are more common. However, several PV power plants have come into service recently using central inverters (e.g., SMA Sunny Central CP XT inverter) and more are under construction. The power converter technology for this is similar to the grid-side converter technology in WTSs, where multi-level technologies can be employed.

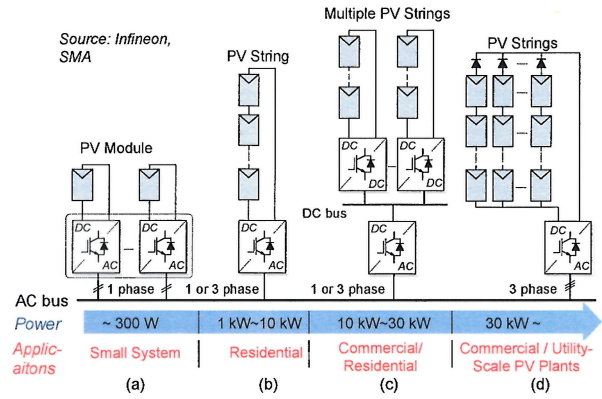

Fig. 7. Grid-connected PV systems with: (a) module inverter, (b) string inverter, (c) multi-string inverter, and (d) central inverter [8].

In respect to the design of PV inverters, the efficiency and leakage current are two main considerations. As aforementioned, transformerless PV inverters are developed for higher efficiency [4], [8], [9], [40]-[45]. A widely adopted single-phase PV inverter is the Full-Bridge (FB) topology as shown in Fig. 10. In the light of safety issues, the FB with a bipolar modulation is feasible in transformerless PV applications. However, the conversion efficiency is not very satisfied. Hence, many other transformerless PV inverters are derived from the FB topology. For instance, the H6 inverter patented by Ingeteam [41] shown in Fig. 11 disconnects the PV panels/strings from the inverter using four extra devices to realize the “isolation”; while the Highly Efficient and Reliable Inverter Concept (HERIC inverter) by Sunways [42] provides an AC bypass. There have been other topologies reported in the literature [9], [43]-[45].

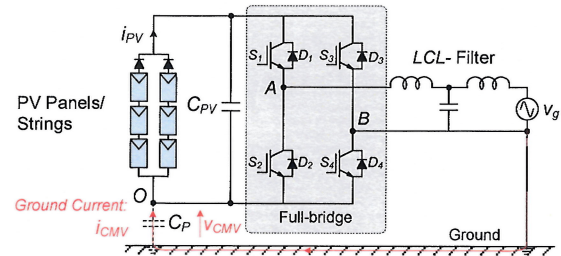

Fig. 10. Single-phase full-bridge PV inverter.

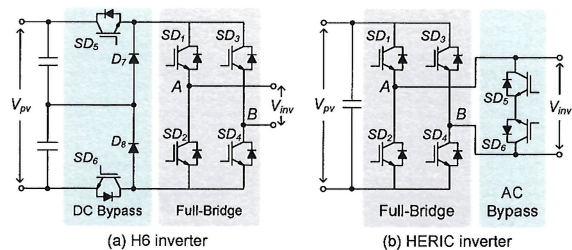

Fig. 11. Two transformerless PV inverters (H6 and HERIC) [41], [42]: (a) H6 inverter and (b) HERIC inverter.

### 3.2 General Control of Renewables

The DSO/TSO has given priority to finding a solution to guarantee stable operation of RESs and thus accept even

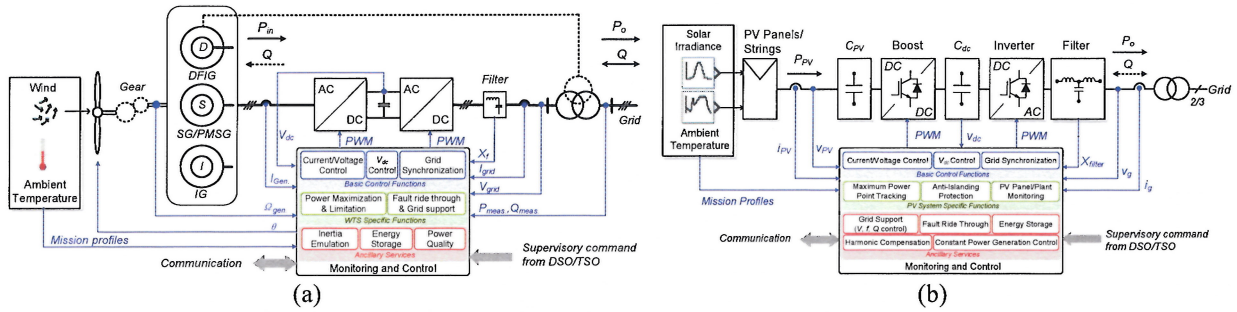

Fig. 12. General control function blocks for: (a) wind turbine power systems and (b) PV power systems.

more renewable energies. This consideration should be taken into account, which makes the control systems of RESs multi-functional, as shown in Fig. 12. The basic controls like current regulation, DC bus stabilization and grid synchronization have to be quickly performed by the power converter, where a Proportional-Integral (PI) controller and Proportional-Resonant (PR) controllers are typically used [6]. As the penetration level of RESs continues growing, it will be mandatory for the RESs to provide ancillary services, such as LVRT, reactive power control and frequency control through active power control, in order to ensure a reliable and efficient power conversion from such renewable energies. Hence, beyond the basic power extracting control, the RESs have also to perform advanced control functions, as shown in Fig. 12.

In addition, the injected current into the grid has to be synchronized well with the grid voltage, as standards require that in the field [4]–[8]. Therefore, the grid synchronization issue plays an important role for both WTSs and PV systems. To address this problem, Phase Locked Loop (PLL) based synchronization methods stand out of various reported solutions [6]. Evaluating criterions for synchronization methods are the dynamic response speed and the disturbance rejection capability. The Second Order Generalized Integrator based PLL (SOGI-PLL) presents a better performance compared to other methods, especially for single-phase systems [4], [6]. It can be a good candidate for the synchronization for RESs and used in industrial applications.

More important, in respect to the aforementioned control methods for WTSs and PV systems, a fast and accurate synchronization system will strongly contribute to the dynamic performance and the stability margin of the whole control systems. The knowledge of grid conditions significantly affects the control systems in different operation modes. For example, the detection of the grid faults and the extraction of positive and negative sequence currents are of importance for the control of RESs in LVRT operation modes.

### 3.3 Advanced Grid Integration

As the heart of every renewable energy generation system, the power electronics converter is responsible for the power generation from wind and solar PV energy efficiently and reliably. Thus, to realize a widespread adop-

tion of such renewables, the power electronics technology will be more active into the grid in the future [46], [47]. Together with advanced control strategies, it can fulfill the upcoming stringent requirements regarding the efficiency, the controllability, the cost and the reliability.

It can be foreseen that more focuses will be devoted on:

- 1) Advancing the power electronics/devices technologies, as well as increasing the utilization of power electronics;
- 2) Developing proper and more stringent grid demands for a better integration of the renewables;
- 3) Lowering the cost of energy [48] by means of improving the conversion efficiency and reducing the system downtime.

Nevertheless, the power electronics technology can enable more advanced integration of renewables into the power grid.

## 4 Conclusions

In this paper, the power electronics technology as the enabling technology for advanced grid integration of renewables has been discussed. After the introduction of demands to renewables, an overview of the mainstream power converter topologies for PV systems and WTSs has also been given, together with their general control strategies. It can be concluded that the power electronics technology is playing an important role in the electricity generation, and is advancing the integration of renewables into the grid. In the future, it is expected that there will be more power electronics systems associated with intelligent control strategies for the renewable energy systems in order to further increase the power capacity, where the power electronics technology will contribute more to the advancement of grid integration.

## 5 References

- [1] REN21, "Renewables 2015: Global Status Report (GSR)," [Online]. Available: [www.ren21.net/](http://www.ren21.net/), Jun. 2015.
- [2] SolarPower Europe, "Global market outlook for solar power – 2015-2019," [Online]. Available: [www.solarpowereurope.org/](http://www.solarpowereurope.org/), Jun. 2015.
- [3] E. J. Coster, J. M. A. Myrzik, B. Kruimer, and W. L. Kling, "Integration issues of distributed generation in distribution grids," *Proc. IEEE*, vol. 99, no. 1, pp. 28–39, Jan. 2011.
- [4] R. Teodorescu, M. Liserre, and P. Rodriguez, *Grid Converters for Photovoltaic and Wind Power Systems*. Hoboken, NJ: Wiley, 2011.

- [5] F. Blaabjerg and D. M. Ionel, "Renewable energy devices and systems – state-of-the-art technology, research and development, challenges and future trends," *Electric Power Components and Systems*, vol. 43, no. 12, pp. 1319-1328, Jul. 2015.
- [6] F. Blaabjerg, R. Teodorescu, M. Liserre, and A.V. Timbus, "Overview of control and grid synchronization for distributed power generation systems," *IEEE Trans. Ind. Electron.*, vol. 53, no. 5, pp. 1398-1409, Oct. 2006.
- [7] Abu-Rub, H., Malinowski, M., and Al-Hadad, K., Eds., *Power Electronics for Renewable Energy Systems, Transportation and Industrial Applications*, Hoboken, NJ: Wiley, 2014.
- [8] S.B. Kjaer, J.K. Pedersen, and F. Blaabjerg, "A review of single-phase grid-connected inverters for photovoltaic modules," *IEEE Trans. Ind. Appl.*, vol. 41, no. 5, pp. 1292-1306, Sept.-Oct. 2005.
- [9] D. Meneses, F. Blaabjerg, O. Garcia, and J.A. Cobos, "Review and comparison of step-up transformerless topologies for photovoltaic AC-module application," *IEEE Trans. Power Electron.*, vol. 28, no. 6, pp. 2649-2663, Jun. 2013.
- [10] F. Blaabjerg and K. Ma, "Future on power electronics for wind turbine systems," *IEEE J. Emerg. Sel. Top. Power Electron.*, vol. 1, no. 3, pp. 139 - 152, Sept. 2013.
- [11] J.M. Carrasco, L.G. Franquelo, J.T. Bialasiewicz, E. Galvan, R.C.P. Guisado, Ma.A.M. Prats, J.I. Leon, and N. Moreno-Alfonso, "Power-electronic systems for the grid integration of renewable energy sources: a survey," *IEEE Trans. Ind. Electron.*, vol. 53, no. 4, pp. 1002-1016, Jun. 2006.
- [12] M. Liserre, T. Sauter, and J.Y. Hung, "Future energy systems: Integrating renewable energy sources into the smart power grid through industrial electronics," *IEEE Ind. Electron. Mag.*, vol. 4, no. 1, pp. 18-37, Mar. 2010.
- [13] M. Liserre, R. Cardenas, M. Molinas, and J. Rodriguez, "Overview of multi-MW wind turbines and wind parks," *IEEE Trans. Ind. Electron.*, vol. 58, no. 4, pp. 1081-1095, Apr. 2011.
- [14] K. Ma and F. Blaabjerg, "Multilevel converters for 10 MW wind turbines," in *Proc. of EPE'11*, pp. 1-10, Aug. 30 2011-Sept. 1 2011.
- [15] F. Blaabjerg, K. Ma, and D. Zhou, "Power electronics and reliability in renewable energy systems," in *Proc. of ISIE*, pp. 19-30, 28-31 May 2012.
- [16] H. Wang, M. Liserre, and F. Blaabjerg, "Toward reliable power electronics: challenges, design tools, and opportunities," *IEEE Ind. Electron. Mag.*, vol. 7, no. 2, pp. 17-26, Jun. 2013.
- [17] K. Ma, L. Tutelea, I. Boldea, D. M. Ionel, and F. Blaabjerg, "Power electronic drives, controls, and electric generators for large wind turbines—an overview," *Electric Power Components and Systems*, vol. 43, no. 12, pp. 1406-1421, Jul. 2015.
- [18] Y. Yang, P. Enjeti, H. Wang, and F. Blaabjerg, "Wide-scale adoption of photovoltaic energy: grid code modifications are explored in the distribution grid," *IEEE Ind. Appl. Mag.*, vol. 21, no. 5, pp. 21-31, Sept.-Oct. 2015.
- [19] N.P. Papanikolaou, "Low-voltage ride-through concept in flyback inverter-based alternating current photovoltaic modules," *IET Power Electron.*, vol. 6, no. 7, pp. 1436-1448, Aug. 2013.
- [20] Y. Bae, T.-K. Vu, and R.-Y. Kim, "Implemental control strategy for grid stabilization of grid-connected PV system based on German grid code in symmetrical low-to-medium voltage network," *IEEE Trans. Energy Conv.*, vol. 28, no. 3, pp. 619-631, Sept. 2013.
- [21] E. ON GmbH, "Grid Code - High and extra high voltage." [Online]. Available: <http://www.eon-netz.com/>.
- [22] Comitato Elettrotecnico Italiano, "CEI 0-21: Reference technical rules for connecting users to the active and passive LV distribution companies of electricity." [Online]. Available: <http://www.ceiweb.it/>.
- [23] P. Rodriguez, A.V. Timbus, R. Teodorescu, M. Liserre, and F. Blaabjerg, "Flexible active power control of distributed power generation systems during grid faults," *IEEE Trans. Ind. Electron.*, vol. 54, no. 5, pp. 2583-2592, Oct. 2007.
- [24] G.M.S. Azevedo, G. Vazquez, A. Luna, D. Aguilar, and A. Rolan, "Photovoltaic inverters with fault ride-through Capability," in *Proc. of ISIE'09*, pp. 549-553, 5-8 Jul. 2009.
- [25] C.H. Benz, W.-T. Franke, and F.W. Fuchs, "Low voltage ride through capability of a 5 kW grid-tied solar inverter," in *Proc. of EPE/PEMC*, pp. T12-13-T12-20, 6-8 Sept. 2010.
- [26] X. Bao, P. Tan, F. Zhuo, and X. Yue, "Low voltage ride through control strategy for high-power grid-connected photovoltaic inverter," in *Proc. of APEC'13*, pp. 97-100, 17-21 Mar. 2013.
- [27] H.-C. Chen, C.-T. Lee, P.T. Cheng, R. Teodorescu, F. Blaabjerg, and S. Bhattacharya, "A flexible low-voltage ride-through operation for the distributed generation converters," in *Proc. of PEDS'13*, pp. 1354-1359, 22-25 Apr. 2013.
- [28] Y. Yang, F. Blaabjerg, and Z. Zou, "Benchmarking of grid fault modes in single-phase grid-connected photovoltaic systems," *IEEE Trans. Ind. Appl.*, vol. 49, no. 5, pp. 2167-2176, Sept./Oct. 2013.
- [29] Y. Yang, F. Blaabjerg, and H. Wang, "Low voltage ride-through of single-phase transformerless photovoltaic inverters," *IEEE Trans. Ind. Appl.*, vol. 50, no. 3, pp. 1942-1952, May/Jun. 2014.
- [30] Meneses, D.; Blaabjerg, F.; Garcia, O.; Cobos, J.A., "Review and Comparison of Step-Up Transformerless Topologies for Photovoltaic AC-Module Application," *IEEE Trans. Power Electron.*, vol. 28, no. 6, pp. 2649-2663, June 2013.
- [31] Y. Yang and F. Blaabjerg, "Overview of single-phase grid-connected photovoltaic systems," *Electric Power Components and Systems*, vol. 43, no. 12, pp. 1352-1363, Jul. 2015.
- [32] T. Kerekes, D. Sera, and L. Mathe, "Three-phase photovoltaic systems: structures, topologies, and control," *Electric Power Components and Systems*, vol. 43, no. 12, pp. 1364-1375, Jul. 2015.
- [33] E. Koutroulis and F. Blaabjerg, "Design optimization of transformerless grid-connected PV inverters including reliability," *IEEE Trans. Power Electron.*, vol. 28, no. 1, pp. 325-335, Jan. 2013.
- [34] Y. Yang, H. Wang, and F. Blaabjerg, "Reliability assessment of transformerless PV inverters considering mission profiles," *International Journal of Photoenergy*, vol. 2015, 10 pages, 2015.
- [35] Energinet – *Technical regulation 3.2.5 for wind power plants with a power output greater than 11 kW*, Sep. 2010.
- [36] E.ON-Netz – *Grid Code. Requirements for offshore grid connections in the E.ON Netz network*, April 2008.
- [37] M. Altin, O. Goksu, R. Teodorescu, P. Rodriguez, B. Bak-Jensen, L. Helle, "Overview of recent grid codes for wind power integration," in *Proc. of OPTIM'2010*, pp.1152-1160, 2010.
- [38] J. Rodriguez, S. Bernet, P.K. Steimer, and I.E. Lizama, "A survey on neutral-point-clamped inverters," *IEEE Trans. Ind. Electron.*, vol. 57, no. 7, pp. 2219-2230, Jul. 2010.
- [39] B. Andresen and J. Birk, "A high power density converter system for the Gamesa G10x 4.5 MW Wind turbine," in *Proc. of EPE*, pp. 1-7, 2007.
- [40] S.V. Araujo, P. Zacharias, and R. Mallwitz, "Highly efficient single-phase transformerless inverters for grid-connected PV systems," *IEEE Trans. Ind. Electron.*, vol. 57, no. 9, pp. 3118-3128, Sept. 2010.
- [41] R. Gonzalez, J. Lopez, P. Sanchis, and L. Marroyo, "Transformerless inverter for single-phase photovoltaic systems," *IEEE Trans. Power Electron.*, vol. 22, no. 2, pp. 693-697, Mar. 2007.
- [42] H. Schmidt, S. Christoph, and J. Ketterer, "Current inverter for direct/alternating currents, has direct and alternating connections with an intermediate power store, a bridge circuit, rectifier diodes and an inductive choke," German Patent DE10 221 592 A1, 4 Dec. 2003.
- [43] I. Patrao, E. Figueres, F. Gonzalez-Espin, and G. Garcera, "Transformerless topologies for grid-connected single-phase photovoltaic inverters," *Renewable and Sustainable Energy Reviews*, vol. 15, no. 7, pp. 3423-3431, Sept. 2011.
- [44] L. Zhang, K. Sun, L. Feng, H. Wu, and Y. Xing, "A family of neutral point clamped full-bridge topologies for transformerless photovoltaic grid-tied inverters," *IEEE Trans. Power Electron.*, vol. 28, no. 2, pp. 730-739, Feb. 2013.
- [45] B. Gu, J. Dominic, J.-S. Lai, C.-L. Chen, T. LaBella, and B. Chen, "High reliability and efficiency single-phase transformerless inverter for grid-connected photovoltaic systems," *IEEE Trans. Power Electron.*, vol. 28, no. 5, pp. 2235-2245, May 2013.
- [46] J.D., van Wyk and F.C. Lee, "On a future for power electronics," *IEEE Journal of Emerging and Selected Topics in Power Electronics*, vol. 1, no. 2, pp. 59-72, Jun. 2013.
- [47] J.G. Kassakian and T.M. Jahns, "Evolving and emerging applications of power electronics in systems," *IEEE Journal of Emerging and Selected Topics in Power Electronics*, vol. 1, no. 2, pp. 47-58, Jun. 2013.
- [48] M. Campbell, J. Blunden, E. Smeloff, and P. Aschenbrenner, "Minimizing utility-scale PV power plant LCOE through the use of high capacity factor configurations," in *Proc. of IEEE PVSC*, pp. 421-426, 7-12 Jun. 2009.