



AALBORG UNIVERSITY
DENMARK

Aalborg Universitet

Power Electronics – The Key Technology for Renewable Energy System Integration

Blaabjerg, Frede; Yang, Yongheng; Ma, Ke; Wang, Xiongfei

Published in:

Proceedings of the 4th International Conference on Renewable Energy Research and Applications, ICRERA 2015

DOI (link to publication from Publisher):

[10.1109/ICRERA.2015.7418680](https://doi.org/10.1109/ICRERA.2015.7418680)

Publication date:

2015

Document Version

Peer reviewed version

[Link to publication from Aalborg University](#)

Citation for published version (APA):

Blaabjerg, F., Yang, Y., Ma, K., & Wang, X. (2015). Power Electronics – The Key Technology for Renewable Energy System Integration. In Proceedings of the 4th International Conference on Renewable Energy Research and Applications, ICRERA 2015 (pp. 1618 - 1626). IEEE Press. DOI: 10.1109/ICRERA.2015.7418680

General rights

Copyright and moral rights for the publications made accessible in the public portal are retained by the authors and/or other copyright owners and it is a condition of accessing publications that users recognise and abide by the legal requirements associated with these rights.

- ? Users may download and print one copy of any publication from the public portal for the purpose of private study or research.
- ? You may not further distribute the material or use it for any profit-making activity or commercial gain
- ? You may freely distribute the URL identifying the publication in the public portal ?

Take down policy

If you believe that this document breaches copyright please contact us at vbn@aub.aau.dk providing details, and we will remove access to the work immediately and investigate your claim.

Power Electronics – The Key Technology for Renewable Energy System Integration

Frede Blaabjerg, Yongheng Yang, Ke Ma, Xiongfei Wang

Department of Energy Technology, Aalborg University
Pontoppidanstraede 101, Aalborg DK-9220, Denmark

fbl@et.aau.dk, yoy@et.aau.dk, kema@et.aau.dk, xwa@et.aau.dk

Abstract

The energy paradigms in many countries (e.g. Germany and Denmark) have experienced a significant change from fossil-based resources to clean renewables (e.g. wind turbines and photovoltaics) in the past few decades. The scenario of highly penetrated renewables is going to be further enhanced – Denmark expects to be 100 % fossil-free by 2050. Consequently, it is required that the production, distribution and use of the energy should be as technologically efficient as possible and incentives to save energy at the end-user should also be strengthened. In order to realize the transition smoothly and effectively, energy conversion systems, currently based on power electronics technology, will again play an essential role in this energy paradigm shift. Using highly efficient power electronics in power generation, power transmission/distribution and end-user application, together with advanced control solutions makes the way for renewable energies. In light of this, some of the most emerging renewable energies, e.g. wind energy and photovoltaic, which by means of power electronics are changing character as a major part in the electricity generation, are explored in this presentation. Issues like technology development, implementation, power converter technologies, control of the systems, and synchronization are addressed. Special focuses are paid on the future trends in power electronics for those systems like how to lower the cost of energy and to develop emerging power devices and better reliability tool.

1 Introduction

Demands of reliable and environmental-friendly electricity generation from Renewable Energy Systems (RESs) have been the main driving force for the RES development [1]-[5]. Consequently, great efforts have been made by many countries (e.g., Germany, Spain, and Denmark) to alter their energy paradigms with more installations of renewables such as wind power, PhotoVoltaic (PV) power, hydropower, and biomass power. Among various renewable power systems, Wind Turbine System (WTS) and PV system technologies are still the most promising technologies, accounting for a large portion of renewable energy generation [4]-[14], and will expand more. However, the increasing adoption of RESs poses two major challenges. One is the energy structure transition – from the conventional and fossil-based energy to renewables. The other one is the wide-scale use of power electronics in the power generation, the grid integration, the power transmission/distribution and the end-user application.

On the other hand, the power electronics technology has become the enabling technology to advance the grid integration of various renewables. Hence, the power electronics systems should be highly efficient and exceedingly reliable. Basically, it should be able to transfer the renewable energies to the power grid. More important, it should be capable to exhibit advanced ancillary functions (e.g.,

Low Voltage Ride-Through, LVRT, grid support with reactive power injection). A wide-scale adoption of power electronics technology makes those completely weather-dependent energies more controllable, but increasingly intricate. Underpinned by intelligent control strategies, the power electronics technology can fulfill the requirements imposed by the distribution/transmission system operators as well as specific demands from the end-users, especially when more advanced power devices and more accurate knowledge of the mission profiles are available.

In this paper, the power electronics technology, enabling a clean and reliable power conversion from renewables, is discussed. In § II, the basic demands to RESs are presented, followed by the WTS and PV technologies including main power converter topologies. Then, typical control strategies for PV systems and wind turbines are presented considering the grid demands. Due to the increasing complexity of the future power systems integrated with a large amount of RESs, in § III, the advanced grid integration enabled by the power electronics technology is summarized. Finally, the conclusions and perspectives are given for the two main renewable energies.

2 Demands to Renewables

Fig. 1 demonstrates the architecture of a typical RES based power system, where the power electronics unit is the core of the system. Increasing penetration of RESs results in rigorous demands to the key component of the entire system, i.e., the power electronics part. As shown in Fig. 1, the tasks of a power electronics based RES are as

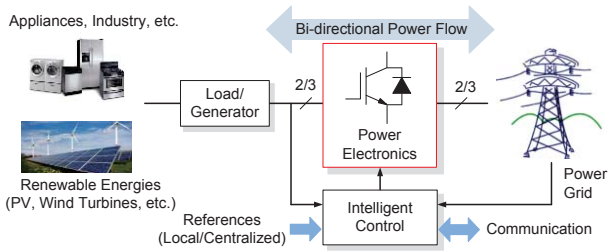

Fig. 1. Power electronics technologies and intelligent control techniques enabled renewable energy system.

varied as they are demanded by the local operators or the end-users [4]-[6]. A very basic demand is to transfer the energy to the grid according to the renewable energy characteristics. Other specific demands to the RESs can be summarized as: a) reliable/secure power supply, b) high efficiency, low cost, small volume, and effective protection, c) control of active and reactive power injected into the grid, d) dynamic grid support (ride-through operation), and e) system monitoring and communication.

2.1 General Requirements for Renewables

2.1.1 Demands to Wind Power Conversion Systems

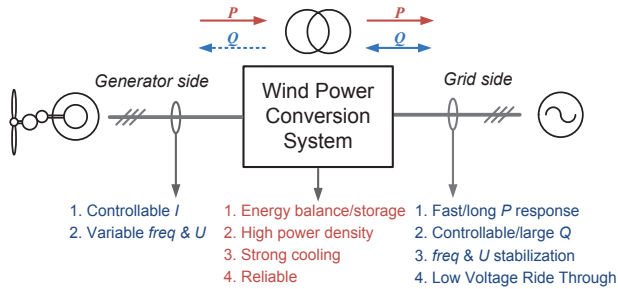

Fig. 2. Demands to wind turbine power systems.

Fig. 2 shows the demands to wind turbine power systems at different levels. Specifically, for the generator side, the generator rotor or stator current should be regulated in order to control the electromagnetic torque of the generator. This means that the generator side current control is not only to maximize the energy harvesting, but also to balance the energy in the case of dynamics due to the inertia mismatch between the mechanical and the electrical power. For the grid side, the requirements are met by controlling the power converter, which must emulate the behaviors of conventional power plants. It means that the converter should help to maintain the grid voltage in terms of frequency and amplitude, and withstand grid faults or even contribute to the fault recovery [4], [6], [11].

Considering the relative large power capacity, failures of wind turbine power systems will impact the grid stability, leading to high cost. Thereby, the reliability is especially emphasized for wind turbine systems [14]-[17]. Also, the voltage level of the wind power generator may need to be boosted up to facilitate the power transmission, and thus transformers are normally required in such systems. Furthermore, owing to the limited physical space in the nacelle and tower of the WTS, power density and cooling

ability are another two crucial issues. Finally, due to the power mismatch between the wind turbine and the grid, and energy storage, energy balancing is important and may result in extra cost.

2.1.2 Demands to PV Power Conversion Systems

Due to the fast development, even tougher requirements have been released for PV systems [18]-[20]. A general categorization of the demands to PV systems is shown in Fig. 3. However, compared to an individual WTS, the power capacity of a PV system is not large. Moreover, the power inertia of the PV output is also compatible with the grid behavior. As a result, the demands to PV systems are less stringent than those to WTSs.

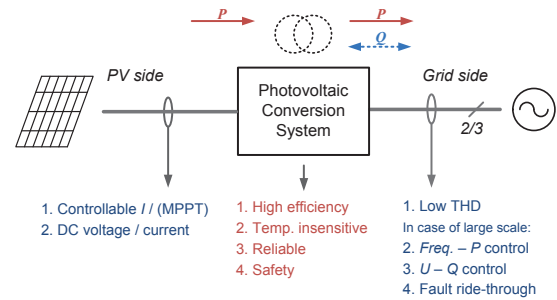

Fig. 3. Demands to PV power conversion systems.

Like the WTS, maximizing energy harvesting is required and it is normally achieved at the PV side, where a dc-dc converter is employed. The dc-dc converter increases the flexibility for energy harvesting. For the grid side, normally the Total Harmonic Distortion (THD) of the output current has to be restrained at a lower level (e.g., 5%) [4], [18]. However, it is noted that future PV systems are getting higher power ratings (e.g., hundreds kW). For those large PV power systems, the grid side also demands the PV inverter to stabilize the grid voltage. For instance, the PV inverters have to ride-through voltage faults, when a higher PV penetration level comes into reality [18]-[29], as what have been required for WTSs.

In addition, for the current PV technology, the power capacity per generating unit is relative low, and however the cost of solar PV energy is relative high. Therefore, strong demands to PV systems for high efficiency are always of interest. As a consequence, in order to further extend the efficiency, transformerless PV inverters have gained much popularity like in Germany and Spain, where the penetration degree of PV systems is high [4], [30]-[32]. However, galvanic safety becomes a crucial issue for transformerless systems. Reduction of the leakage current is thus required in transformerless PV systems. Furthermore, similar to the WTS, reliability is getting more importance in power electronics (including PV systems). This can contribute to extended total energy production and reduced cost of energy [18], [33], [34]. Finally, because of exposure or smaller housing chamber, the PV converter should be more temperature insensitive, which in return is good from the reliability point of view.

2.2 Grid Integration Requirements

Fluctuation and unpredictability are the inherent characteristics of renewables, which however is not preferable for grid operation. Hence, the grid integration focuses on the RES connection point in order to alleviate the potential hazards to the grid. It means that, the RESs should: a) passively and simply inject the extracted power to the grid and b) behave like an active player, which can flexibly manage the power exchange between the generation unit and the grid, and also provide ancillary services to the grid (e.g., frequency/voltage support), as it has been aforementioned.

In the current active grid requirements, the grid integrated systems should control the active power at the Point-of-Common-Coupling (PCC), where the active power has to be regulated according to the grid frequency. For example, in Denmark, the active power should be reduced in the case that the frequency drops below 48.7 Hz or rises above 50.15 Hz depending on the power reserving strategy [35]. Similarly, the reactive power provided by the RESs should also be within a certain range, as it is demonstrated in Fig. 4, where a range of the reactive power by the WTSs in respect to the active power [36] is defined. Moreover, the Transmission System Operator (TSO) will normally specify the reactive power range in order to maintain the grid voltage levels. Notably, this reactive power control should be realized slowly (e.g., under the time constant of minutes) in the steady state operation [37].

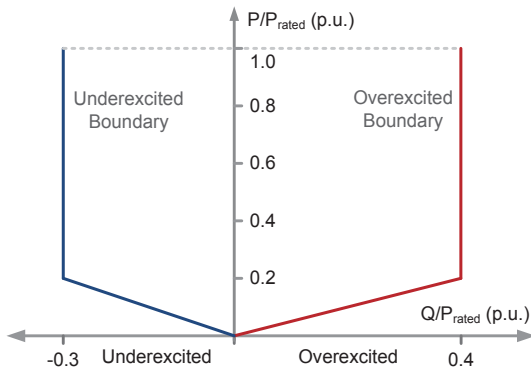

Fig. 4. Reactive power ranges for a wind farm specified in the German grid codes [36].

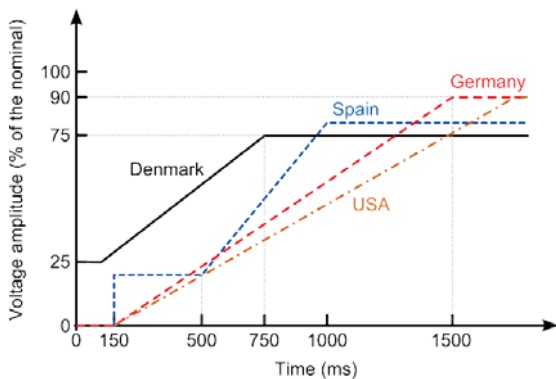

Fig. 5. Voltage profiles for the low voltage ride-through (LVRT) capability defined by different countries [37].

In addition to the normal operation, the TSOs in different countries have also released grid support requirements for the generating units in response to grid faults, as it is exemplified in Fig. 5 [36], [37], where voltage profiles are defined for wind turbine systems under grid faults. Furthermore, it has become a demand that the RES system should also provide reactive power for the voltage recovery. The requirements for more grid supports by the grid-connected renewables on one hand have increased the cost per produced kWh, but on the other hand made them more suitable to be largely utilized and integrated into the grid. It can be predicted that more stringent grid codes or requirements in the future will keep challenging the integration of renewable systems and thus pushing forward the power electronic technologies.

3 Power Electronics Technology – advancing the grid integration

The design and operation of power electronics converters for both wind turbine and PV systems strongly rely on the grid requirements and the energy demand. It can be seen from the evolution of wind turbine power converters, which has changed from non-power-electronics-based topologies to full-scale power converters with increasing power ratings of individual wind turbine [4], [10]-[12]. As the demand of higher power ratings and efficiency increases for PV systems, the PV power converters also had experienced a clear change, and they are mostly transformerless nowadays [4], [8], [9], [31].

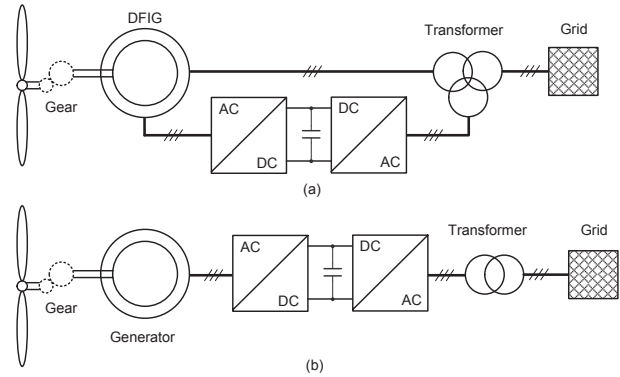

Fig. 6. Dominant WTS configurations: a) variable speed wind turbine with partial-scale power converter and a doubly fed induction generator and (b) variable speed wind turbine with full-scale power converter and an asynchronous/synchronous generator.

3.1 Power Converter Technology

3.1.1 Power Converters for WTSs

Depending on the types of generator, power electronics, speed controllability, and the way in which the aerodynamic power is limited, several wind turbine design concepts are available. In these applications, the power converters play different roles and have various power ratings. Up till now, the Doubly Fed Induction Generator (DFIG) with partial-scale power converters still dominates the market, as it is shown in Fig. 6(a). In very near

future, the Synchronous Generator (SG) with full-scale power converters will take over the WTS market [10], [14], [17], as it is shown in Fig. 6(b). Each of the WTS concepts has its suitable converter topologies and some of them are illustrated in the following.

A. Two-level power converters

Due to simplicity, the two-Level Voltage Source Converter (2L-VSC) is the most common solution so far in the DFIG WTSs, since the power rating requirement is limited. In practice, two Back-To-Back (BTB) 2L-VSCs are configured, as shown in Fig. 7. One advantage of the 2L-BTB solution lies in the full power controllability with a relatively simple structure and few components, which in return contribute to a well-proven, robust, and reliable performance, and also lower cost.

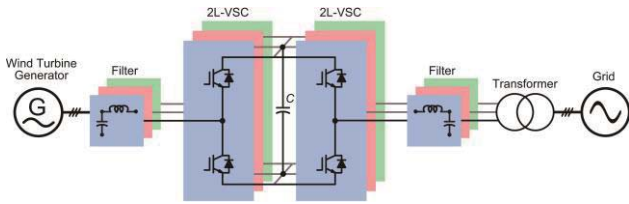

Fig. 7. 2L-VSC BTB voltage source converter for WTSs.

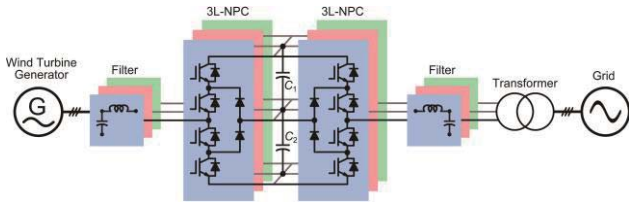

Fig. 8. 3L-NPC BTB topology for WTSs.

B. Multi-level power converters

In order to handle higher voltages and higher power ratings, multi-level power converters are getting more popularity in WTS applications [13], [14]. The three-Level Neutral Point Clamped (3L-NPC) topology is one of the multi-level topologies on the market, as shown in Fig. 8. The 3L-NPC BTB solution achieves one more output voltage levels and less dv/dt stresses in contrast to the 2L-BTB, and thus it is possible to convert the power at MV level with lower currents, less paralleled devices, and smaller filter size. The main drawback of the 3L-NPC BTB is the mid-point voltage fluctuation of the DC-bus, which has been extensively investigated [14], [38].

To deal with the still fast growth in the power capacity of wind turbine systems, multi-cell converter configurations (i.e., parallel and/or series connection of converter units) are also being developed and becoming widely commercialized in the wind turbine industry [39].

3.1.2 Power Converters for PV Systems

For PV systems, a general classification of grid-connected PV inverters is shown in Fig. [8], [31]. A common central inverter can be used in a PV plant larger than tens kWp with higher efficiency and lower cost [8]. Compared

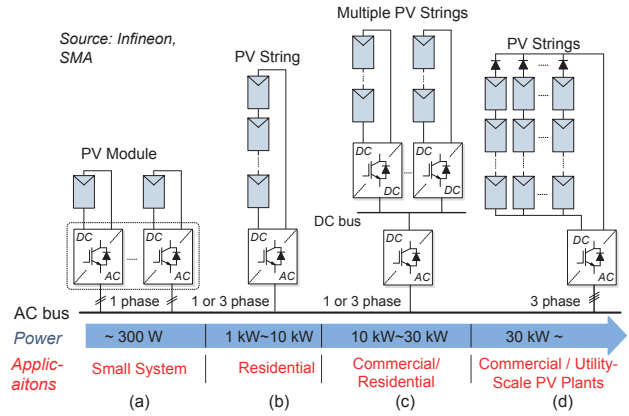

Fig. 9. Grid-connected PV configurations based on: (a) module inverter, (b) string inverter, (c) multi-string inverter, and (d) central inverter [8].

to central inverters, the string inverter can achieve MPPT separately, leading to better total energy yield. The module inverter acts on a single PV panel with a single MPPT. As shown in Fig. 9, another PV technology is an intermediate solution between the string inverter and the module inverter, being multi-string inverter. This configuration can achieve a relatively high efficiency because each PV string is controlled separately.

Additionally, the PV systems are still dominant in residential applications with much lower power ratings (e.g. several kW). Thus, single-phase topologies are more common. However, several PV power plants have come into service recently using central inverters (e.g., SMA Sunny Central CP XT inverter) and more are under construction. The power converter technology for this is similar to the grid-side converter technology in WTSs, where multi-level technologies can be employed.

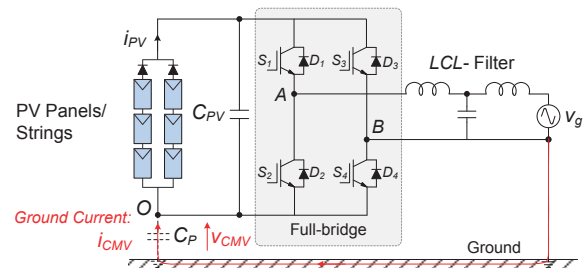

Fig. 7. Single-phase full-bridge PV inverter.

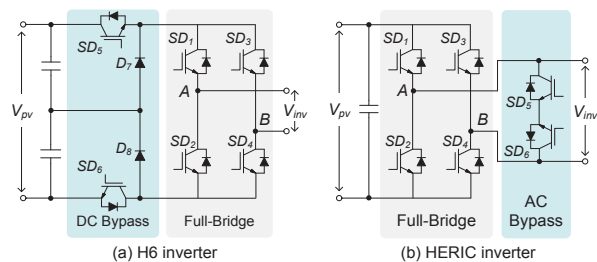

Fig. 8. Two transformerless PV inverters (H6 and HERIC) [41], [42]: (a) H6 inverter and (b) HERIC inverter.

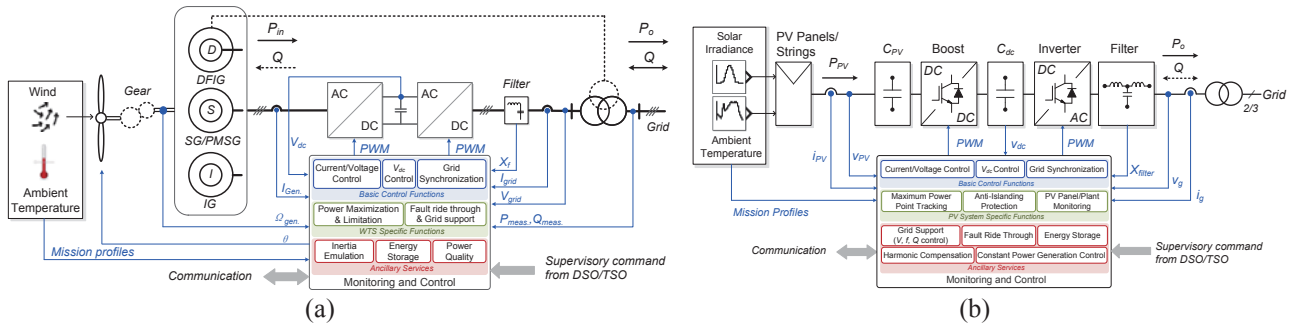

Fig. 9. General control function blocks for: (a) wind turbine power systems and (b) PV power systems.

In respect to the design of PV inverters, the efficiency and leakage current are two main considerations. As aforementioned, transformerless PV inverters are developed for higher efficiency [4], [8], [9], [40]-[45]. A widely adopted single-phase PV inverter is the Full-Bridge (FB) topology as shown in Fig. 7. In the light of safety issues, the FB with a bipolar modulation is feasible in transformerless PV applications. However, the conversion efficiency is not very satisfied. Hence, many other transformerless PV inverters are derived from the FB topology. For instance, the H6 inverter patented by Ingeteam [41] shown in Fig. 8 disconnects the PV panels/strings from the inverter using four extra devices to realize the “isolation”; while the Highly Efficient and Reliable Inverter Concept (HERIC inverter) by Sunways [42] provides an AC bypass. There have been other topologies reported in the literature [9], [43]-[45].

3.2 General Control of Renewables

The DSO/TSO has prioritized schemes to guarantee stable operation of RESs in such a way that even more renewable energies can be installed. This consideration makes the control systems of RESs multi-functional, as it is shown in Fig. 9. The basic controls like current regulation, DC bus stabilization and grid synchronization have to be performed by the power converter with fast dynamics, where a Proportional-Integral (PI) controller and Proportional-Resonant (PR) controllers are widely used [6]. As the penetration level of RESs continues growing, provision of ancillary services like LVRT, reactive power control and frequency control through active power control are becoming more stringent to achieve a reliable and efficient power conversion from renewables. As a result, beyond the basic power extracting control, the RESs have also to perform advanced control functions, as shown in Fig. 9.

In addition, the grid feed-in current should be well-synchronized with the grid voltage, as standards in relevant fields require so [4]-[8]. Therefore, the grid synchronization issue is very important for both WTSS and PV systems. To address this problem, Phase Locked Loop (PLL) based synchronization methods stand out of various reported solutions [6]. Evaluating criterions for synchronization methods are the dynamic response speed and the disturbance rejection capability. Among various syn-

chronization techniques, the Second Order Generalized Integrator based PLL (SOGI-PLL) presents a better performance compared to its counterparts, especially for single-phase grid-connected systems [4], [6]. It can be a good candidate for the synchronization for RESs and used in industrial applications.

More important, in respect to the aforementioned control methods for WTSS and PV systems, a fast and accurate synchronization system will contribute to the dynamic performance and potentially the stability margin of the whole control systems, as recently investigated in [46]. The knowledge of grid conditions significantly affects the control systems in different operation modes. For example, the detection of the grid faults and the extraction of positive and negative sequence currents are of importance for the control of RESs in LVRT operation modes.

3.3 System Integration of Renewables

To facilitate a widespread deployment of renewables, the power electronics technology will be more active into the grid in the future [47], [48]. Dynamic interactions among those power electronics based sources will become more apparent, which will consequently bring more challenges for the stability and power quality of future power grids.

Advanced control strategies are therefore demanded for reshaping the dynamic behaviors of grid-interfaced power converters in order not to destabilize the power grids [49], [50]. Characterizing the dynamics of grid-connected converters at the different time/frequency scales within the various operating scenarios are getting more important for developing control strategies [51]. Many research efforts have been made to reveal the dynamic interactions among converters in renewable power plants, and to develop the effective control schemes for preventing any instability. The frequency-domain passivity-based control and virtual impedance control, among other alternatives, provides a flexible but robust way to stabilize power electronic based power systems [52], [53].

Besides developing more advanced control strategies, the power electronic converters can also be customized as an active damper for stabilizing the integration of renewable power plants [54], [55]. Fig. 13 illustrates the basic concept of the active damper to stabilize a power electronic

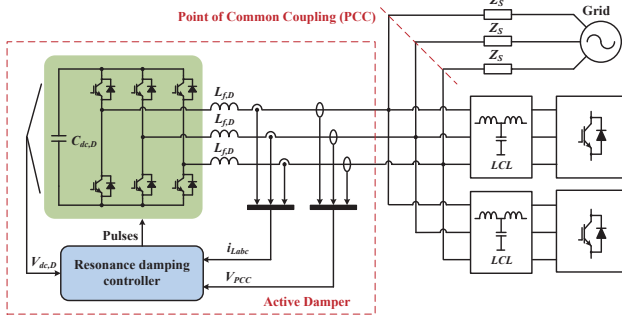

Fig. 13. Active damper for stabilizing a power electronic based power system [54].

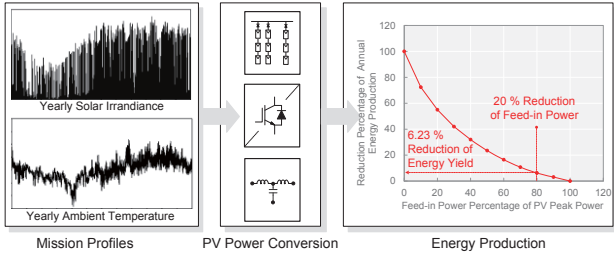

Fig. 14. Energy reduction due to the limitation of maximum feed-in power.

based power system. Although it looks like an active power filter, it is designed for synthesizing a damping at high resonance frequencies, whereas the low-order harmonic compensation is not undertaken by the damper. This unique feature allows a low-power, high switching frequency design for the active damper, and thus enables a wideband control system for high-frequency damping.

4 Future Trends

4.1 More Stringent Grid Codes

In order to accept more renewables in the grid, the conventional power grid, which is normally based on centralized power plants, have to be revised to be more distributed and smaller generation units. Hence, new demands to grid integration standards, communication, power flow control, and protection are needed. Power electronic converters together with dedicated and intelligent control strategies again play an important role in this technology transformation.

Taking the PV systems as an example, typically, a MPPT is required during the operation. However, recent studies showed that a limitation of the maximum feed-in power from PV systems only contributes a limited energy reduction, as it is shown in Fig. 14. Thus, it is reasonable to avoid upgrading power infrastructure by limiting the maximum feed-in power from PV systems. This may be enhanced in the future grid demands at a very high penetration level. The same philosophy may be imposed on other renewables (e.g. fuel-cell system). In that case, the control of power electronics should be ready. In fact, this limiting maximum feed-in power control can be treated as an extension of the active power constraints in the Danish

grid code for wind turbine systems. The control concept is also referred to as a constant power generation control [56], [57] or a reduced active power control [58].

To demonstrate the Constant Power Generation (CPG) control scheme, a single-phase two-stage PV system was built up in the FlexLab 2 at Aalborg University. The PV system consists of a 3 kW fully-programmable PV simulator, a dc-dc converter, a full-bridge PV inverter, and an LC filter connected to the grid. The constant power generation control is achieved by controlling the dc-dc boost converter. The experimental results are shown in Fig. 15, where a daily real-field solar irradiance was considered and the power limit is set as 80% of the rated power (i.e., 2.4 kW). The instantaneous output power of the PV panel can be given as

$$p_o(t) = \begin{cases} p_{MPPT}(t), & \text{when } p_{MPPT}(t) < P_{limit} \\ P_{limit}, & \text{when } p_{MPPT}(t) \geq P_{limit} \end{cases} \quad (1)$$

in which $p_o(t)$ is the PV actual instantaneous output power, p_{MPPT} is the power when using a MPPT control, and P_{limit} is the power limit.

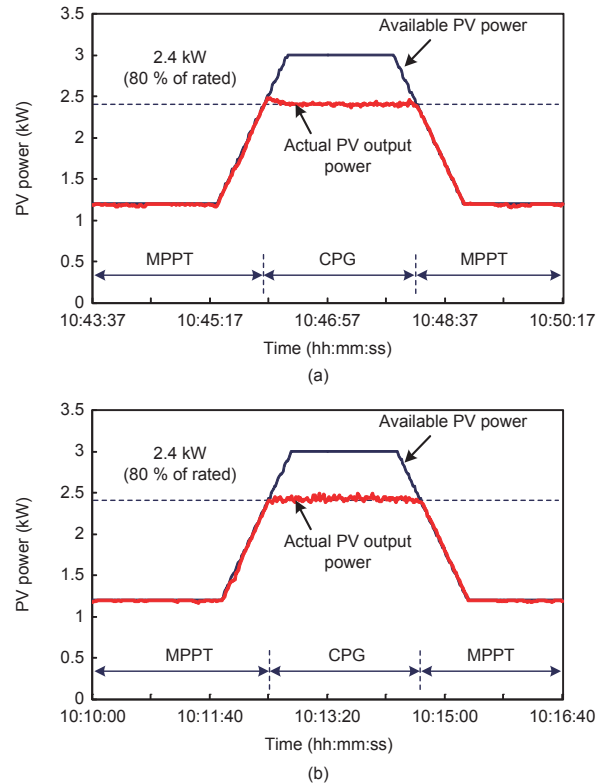

Fig. 15. Performance of a 3-kW single-phase two-stage PV system with an emerging active power control scheme (i.e., constant power generation control) when: (a) the operating point is at the left side of the MPPT point and (b) the operating point is at the right side of the MPPT point.

As it can be observed in Fig. 15, the CPG control can ensure that the PV system is operating either at the left-side or the right-side of the maximum power point, both leading to a constant output power to the grid. However, the

dynamics are different. For instance, at the right-side, the PV system can quickly maintain the output power to be constant (e.g., 2.4 kW), but at the same time, the power variation is also large since in that region the dp/dv is very large. Nevertheless, the effectiveness of the CPG control has been demonstrated by the experiments.

4.2 High-Power Semiconductor Devices

Power semiconductor devices are the backbone in power electronic systems and will determine many critical performances of renewable energy systems such as the cost, efficiency, reliability, modularity. The high-power silicon-based power semiconductors will be the main driving forces for the next-generation wind power application, which are among the module packaged *Insulated Gate Bipolar Transistor* (IGBT), press-pack packaged IGBT and the press-pack packaging *Integrated Gate Commutated Thyristor* (IGCT).

The module packaging technology of IGBT has a longer track record of applications and fewer mounting regulations. However, because of the soldering and bond-wire connection of internal chips, module packaging devices may suffer from larger thermal resistance, lower power density and higher failure rates. The main trends to improve the packaging technology of IGBT module are to introduce pressure contact to eliminate the base plate and thus base plate soldering, sinter technology to avoid the chip soldering, as well as replaced bond wire material to reduce the coefficient of thermal expansion – all lead to increased lifetime of module packaging IGBTs.

The press-pack packaging technology improves the connection of chips by direct press-pack contacting, which leads to improved reliability (yet to be scientifically proved but known from industrial experience), higher power density (easier stacking for series connection) and better cooling capability. Press-pack IGCTs were first introduced into the medium-voltage motor drivers in the 1990's and has already become state-of-the-art technology in the applications of oil, gas, HVDC, power quality, etc. However IGCT have not yet been mass adopted in the wind turbine system. As the power capacity of wind turbines grows up even to 10 MW, it can be expected that the press pack packaging devices may become more promising for the future wind turbine system.

4.3 Lower Cost of Energy

Reducing the cost of energy is one of the most important considerations, which may affect the installation capacity of the energy technologies. Generally, a Levelized Cost of Energy (LCOE) index is adopted to quantify and compare the cost for different renewables [33], [59], [60]. The possibilities to lower the cost of energy are: a) to reduce the cost for development, capital, operation and maintenance and b) to extend the energy production or increase the lifetime of the generation system.

As it is shown in Fig. 16, the onshore wind power technology is currently competitive with the fossil-based power generation in terms of the cost, while offshore wind power and solar PV technologies are still more expensive than the onshore wind power. The cost advantage is the main contribution to the significant adoption of onshore wind power systems in the past few decades. As it is indicated in Fig. 16, there is large potential to reduce the cost of offshore wind and solar PV technologies in the future. Since the power electronics technology is the key technology for RESs with higher power ratings, special cost considerations should also be taken into account for the design and control of power electronics converters.

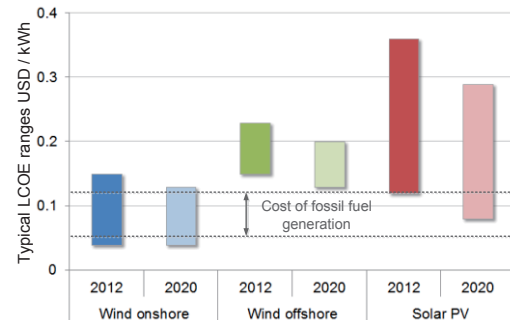

Fig. 16. Estimated LCOE for several renewable energy technologies for entering service in 2018 [60].

4.4 High Efficiency and High Reliability

Achieving high efficiency and high reliability are always of intense interest in order to reduce energy losses and to extend service time, and it will be further strengthened in the future RESs. Improvements of efficiency can be achieved by integrating more power electronics systems with intelligent control strategies and developing more advanced power electronics devices (e.g. SiC-based modules). As the devices and components that comprise the power electronics system in a RES, the behavior of the power electronics devices will impose constraints on the system conversion performance [16]. Thus, for the future wind power systems with high power ratings, using advanced power electronics devices can improve the system efficiency and reliability.

Notably, the dramatic growth of total installations and the individual capacity make the failures of wind power or PV system costly or even unacceptable. In view of this, the reliability is another critical requirement for the future RESs [10], [14], [16]. According to previous research and field experiences, the control and power electronics systems in a RES have higher failure rate than the other subsystems. Therefore, possible improvements of the reliability can be achieved by means of: a) proper component selection (e.g. considering rated power, the most stressed situations, and the severe users, using advanced device packaging technologies, and choosing new power electronics devices), b) effective thermal management, c) robustness design and validation with the knowledge of mission profiles [10], [16]. This consideration should be

taken into during the design and operation of a RES. It also leads to possible activities for reliability analysis and improvement as illustrated in Fig. 17.

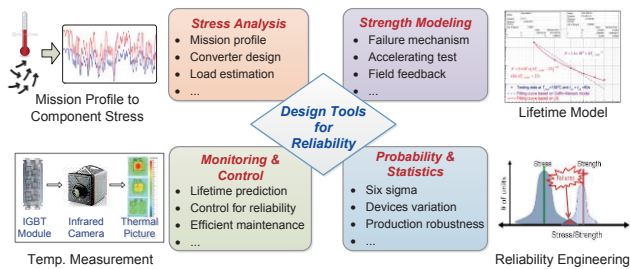

Fig. 17. Multi-disciplinary approaches for more reliable power electronics in renewable energy systems.

5 Conclusions

In this paper, the power electronics technology as the enabling technology for advanced grid integration of renewables has been discussed. After the introduction of demands to renewables, an overview of the mainstream power converter topologies for PV systems and WTSs has also been given, together with their general control strategies. It can be concluded that the power electronics technology is playing an important role in the electricity generation, and is advancing the integration of renewables into the grid.

6 References

- [1] REN21, "Renewables 2015: Global Status Report (GSR)," [Online]. Available: www.ren21.net/, Jun. 2015.
- [2] SolarPower Europe, "Global market outlook for solar power – 2015-2019," [Online]. Available: www.solarpowereurope.org/, Jun. 2015.
- [3] E. J. Coster, J. M. A. Myrzik, B. Kruimer, and W. L. Kling, "Integration issues of distributed generation in distribution grids," *Proc. IEEE*, vol. 99, no. 1, pp. 28–39, Jan. 2011.
- [4] R. Teodorescu, M. Liserre, and P. Rodriguez, *Grid Converters for Photovoltaic and Wind Power Systems*. Hoboken, NJ: Wiley, 2011.
- [5] F. Blaabjerg and D. M. Ionel, "Renewable energy devices and systems – state-of-the-art technology, research and development, challenges and future trends," *Electric Power Components and Systems*, vol. 43, no. 12, pp. 1319–1328, Jul. 2015.
- [6] F. Blaabjerg, R. Teodorescu, M. Liserre, and A.V. Timbus, "Overview of control and grid synchronization for distributed power generation systems," *IEEE Trans. Ind. Electron.*, vol. 53, no. 5, pp. 1398–1409, Oct. 2006.
- [7] Abu-Rub, H., Malinowski, M., and Al-Hadad, K., Eds., *Power Electronics for Renewable Energy Systems, Transportation and Industrial Applications*, Hoboken, NJ: Wiley, 2014.
- [8] S.B. Kjaer, J.K. Pedersen, and F. Blaabjerg, "A review of single-phase grid-connected inverters for photovoltaic modules," *IEEE Trans. Ind. Appl.*, vol. 41, no. 5, pp. 1292–1306, Sept.-Oct. 2005.
- [9] D. Meneses, F. Blaabjerg, O. Garcia, and J.A. Cobos, "Review and comparison of step-up transformerless topologies for photovoltaic AC-module application," *IEEE Trans. Power Electron.*, vol. 28, no. 6, pp. 2649–2663, Jun. 2013.
- [10] F. Blaabjerg and K. Ma, "Future on power electronics for wind turbine systems," *IEEE J. Emerg. Sel. Top. Power Electron.*, vol. 1, no. 3, pp. 139–152, Sept. 2013.
- [11] J.M. Carrasco, L.G. Franquelo, J.T. Bialasiewicz, E. Galvan, R.C.P. Guisado, Ma.A.M. Prats, J.I. Leon, and N. Moreno-Alfonso, "Power-electronic systems for the grid integration of renewable energy sources: a survey," *IEEE Trans. Ind. Electron.*, vol. 53, no. 4, pp. 1002–1016, Jun. 2006.
- [12] M. Liserre, T. Sauter, and J.Y. Hung, "Future energy systems: Integrating renewable energy sources into the smart power grid through industrial electronics," *IEEE Ind. Electron. Mag.*, vol. 4, no. 1, pp. 18–37, Mar. 2010.
- [13] M. Liserre, R. Cardenas, M. Molinas, and J. Rodriguez, "Overview of multi-MW wind turbines and wind parks," *IEEE Trans. Ind. Electron.*, vol. 58, no. 4, pp. 1081–1095, Apr. 2011.
- [14] K. Ma and F. Blaabjerg, "Multilevel converters for 10 MW wind turbines," in *Proc. of EPE'11*, pp. 1–10, Aug. 30 2011–Sept. 1 2011.
- [15] F. Blaabjerg, K. Ma, and D. Zhou, "Power electronics and reliability in renewable energy systems," in *Proc. of ISIE*, pp. 19–30, 28–31 May 2012.
- [16] H. Wang, M. Liserre, and F. Blaabjerg, "Toward reliable power electronics: challenges, design tools, and opportunities," *IEEE Ind. Electron. Mag.*, vol. 7, no. 2, pp. 17–26, Jun. 2013.
- [17] K. Ma, L. Tutelea, I. Boldea, D. M. Ionel, and F. Blaabjerg, "Power electronic drives, controls, and electric generators for large wind turbines—an overview," *Electric Power Components and Systems*, vol. 43, no. 12, pp. 1406–1421, Jul. 2015.
- [18] Y. Yang, P. Enjeti, H. Wang, and F. Blaabjerg, "Wide-scale adoption of photovoltaic energy: grid code modifications are explored in the distribution grid," *IEEE Ind. Appl. Mag.*, vol. 21, no. 5, pp. 21–31, Sept.-Oct. 2015.
- [19] N.P. Papanikolaou, "Low-voltage ride-through concept in flyback inverter-based alternating current photovoltaic modules," *IET Power Electron.*, vol. 6, no. 7, pp. 1436–1448, Aug. 2013.
- [20] Y. Bae, T.-K. Vu, and R.-Y. Kim, "Implemental control strategy for grid stabilization of grid-connected PV system based on german grid code in symmetrical low-to-medium voltage network," *IEEE Trans. Energy Conv.*, vol. 28, no. 3, pp. 619–631, Sept. 2013.
- [21] E. ON GmbH, "Grid Code - High and extra high voltage." [Online]. Available: <http://www.eon-netz.com/>.
- [22] Comitato Elettrotecnico Italiano, "CEI 0-21: Reference technical rules for connecting users to the active and passive LV distribution companies of electricity." [Online]. Available: <http://www.ceiweb.it/>.
- [23] P. Rodriguez, A.V. Timbus, R. Teodorescu, M. Liserre, and F. Blaabjerg, "Flexible active power control of distributed power generation systems during grid faults," *IEEE Trans. Ind. Electron.*, vol. 54, no. 5, pp. 2583–2592, Oct. 2007.
- [24] G.M.S. Azevedo, G. Vazquez, A. Luna, D. Aguilar, and A. Rolan, "Photovoltaic inverters with fault ride-through Capability," in *Proc. of ISIE'09*, pp. 549–553, 5–8 Jul. 2009.
- [25] C.H. Benz, W.-T. Franke, and F.W. Fuchs, "Low voltage ride through capability of a 5 kW grid-tied solar inverter," in *Proc. of EPE/PEMC*, pp. T12-13-T12-20, 6–8 Sept. 2010.
- [26] X. Bao, P. Tan, F. Zhuo, and X. Yue, "Low voltage ride through control strategy for high-power grid-connected photovoltaic inverter," in *Proc. of APEC'13*, pp. 97–100, 17–21 Mar. 2013.
- [27] H.-C. Chen, C.-T. Lee, P.T. Cheng, R. Teodorescu, F. Blaabjerg, and S. Bhattacharya, "A flexible low-voltage ride-through operation for the distributed generation converters," in *Proc. of PEDS'13*, pp. 1354–1359, 22–25 Apr. 2013.
- [28] Y. Yang, F. Blaabjerg, and Z. Zou, "Benchmarking of grid fault modes in single-phase grid-connected photovoltaic systems," *IEEE Trans. Ind. Appl.*, vol. 49, no. 5, pp. 2167–2176, Sept./Oct. 2013.
- [29] Y. Yang, F. Blaabjerg, and H. Wang, "Low voltage ride-through of single-phase transformerless photovoltaic inverters," *IEEE Trans. Ind. Appl.*, vol. 50, no. 3, pp. 1942–1952, May/Jun. 2014.
- [30] Meneses, D.; Blaabjerg, F.; Garcia, O.; Cobos, J.A., "Review and Comparison of Step-Up Transformerless Topologies for Photovoltaic AC-Module Application," *IEEE Trans. Power Electron.*, vol. 28, no. 6, pp. 2649–2663, June 2013.
- [31] Y. Yang and F. Blaabjerg, "Overview of single-phase grid-connected photovoltaic systems," *Electric Power Components and Systems*, vol. 43, no. 12, pp. 1352–1363, Jul. 2015.
- [32] T. Kerekes, D. Sera, and L. Mathe, "Three-phase photovoltaic systems: structures, topologies, and control," *Electric Power Components and Systems*, vol. 43, no. 12, pp. 1364–1375, Jul. 2015.
- [33] E. Koutroulis and F. Blaabjerg, "Design optimization of transformerless grid-connected PV inverters including reliability," *IEEE Trans. Power Electron.*, vol. 28, no. 1, pp. 325–335, Jan. 2013.

- [34] Y. Yang, H. Wang, and F. Blaabjerg, "Reliability assessment of transformerless PV inverters considering mission profiles," *International Journal of Photoenergy*, vol. 2015, 10 pages, 2015.
- [35] Energinet – *Technical regulation 3.2.5 for wind power plants with a power output greater than 11 kW*, Sep. 2010.
- [36] E.ON-Netz – *Grid Code. Requirements for offshore grid connections in the E.ON Netz network*, April 2008.
- [37] M. Altin, O. Goksu, R. Teodorescu, P. Rodriguez, B. Bak-Jensen, L. Helle, "Overview of recent grid codes for wind power integration," in *Proc. of OPTIM'2010*, pp.1152-1160, 2010.
- [38] J. Rodriguez, S. Bernet, P.K. Steimer, and I.E. Lizama, "A survey on neutral-point-clamped inverters," *IEEE Trans. Ind. Electron.*, vol. 57, no. 7, pp. 2219-2230, Jul. 2010.
- [39] B. Andresen and J. Birk, "A high power density converter system for the Gamesa G10x 4.5 MW Wind turbine," in *Proc. of EPE*, pp. 1-7, 2007.
- [40] S.V. Araujo, P. Zacharias, and R. Mallwitz, "Highly efficient single-phase transformerless inverters for grid-connected PV systems," *IEEE Trans. Ind. Electron.*, vol. 57, no. 9, pp. 3118-3128, Sept. 2010.
- [41] R. Gonzalez, J. Lopez, P. Sanchis, and L. Marroyo, "Transformerless inverter for single-phase photovoltaic systems," *IEEE Trans. Power Electron.*, vol. 22, no. 2, pp. 693-697, Mar. 2007.
- [42] H. Schmidt, S. Christoph, and J. Ketterer, "Current inverter for direct/alternating currents, has direct and alternating connections with an intermediate power store, a bridge circuit, rectifier diodes and a inductive choke," German Patent DE10 221 592 A1, 4 Dec. 2003.
- [43] I. Patrao, E. Figueres, F. Gonzalez-Espin, and G. Garcera, "Transformerless topologies for grid-connected single-phase photovoltaic inverters," *Renewable and Sustainable Energy Reviews*, vol. 15, no. 7, pp. 3423-3431, Sept. 2011.
- [44] L. Zhang, K. Sun, L. Feng, H. Wu, and Y. Xing, "A family of neutral point clamped full-bridge topologies for transformerless photovoltaic grid-tied inverters," *IEEE Trans. Power Electron.*, vol. 28, no. 2, pp. 730-739, Feb. 2013.
- [45] B. Gu, J. Dominic, J.-S. Lai, C.-L. Chen, T. LaBella, and B. Chen, "High reliability and efficiency single-phase transformerless inverter for grid-connected photovoltaic systems," *IEEE Trans. Power Electron.*, vol. 28, no. 5, pp. 2235-2245, May 2013.
- [46] B. Wen, D. Dong, D. Boroyevich, R. Burgos, P. Mattavelli, and Z. Shen, "Impedance-based analysis of grid-synchronization stability for three-phase paralleled converters," *IEEE Trans. Power Electron.*, vol. 31, no. 1, pp. 26-38, Jan. 2016.
- [47] J.D. van Wyk and F.C. Lee, "On a future for power electronics," *IEEE Journal of Emerging and Selected Topics in Power Electronics*, vol. 1, no. 2, pp. 59-72, Jun. 2013.
- [48] J.G. Kassakian and T.M. Jahns, "Evolving and emerging applications of power electronics in systems," *IEEE Journal of Emerging and Selected Topics in Power Electronics*, vol. 1, no. 2, pp. 47-58, Jun. 2013.
- [49] R. Turner, S. Walton, and R. Duke, "Robust high-performance inverter control using discrete direct-design pole placement," *IEEE Trans. Ind. Electron.* vol. 58, no. 1, pp. 348-357, Jan. 2011.
- [50] X. Wang, F. Blaabjerg, and P. C. Loh, "Virtual RC damping of LCL-filtered voltage source converters with extended selective harmonic compensation," *IEEE Trans. Power Electron.*, vol. 30, no. 9, pp. 4726-4737, Sept. 2015.
- [51] X. Wang, F. Blaabjerg, and W. Wu, "Modeling and analysis of harmonic stability in an AC power-electronics-based power system," *IEEE Trans. Power Electron.*, vol. 29, no. 12, pp. 6421-6432, Dec. 2014.
- [52] L. Harnefors, A. G. Yepes, A. Vidal, and J. Doval-Gandoy, "Passivity-based controller design of grid-connected VSCs for prevention of electrical resonance instability," *IEEE Trans. Ind. Electron.* vol. 62, no. 2, pp. 702-710, Feb. 2015.
- [53] X. Wang, Y. W. Li, F. Blaabjerg, and P. C. Loh, "Virtual-impedance-based control for voltage-source and current-source converters," *IEEE Trans. Power Electron.*, vol. 99, no. 99, pp. 1-20, Dec. 2014.
- [54] X. Wang, F. Blaabjerg, M. Liserre, Z. Chen, J. He, and Y. W. Li, "An active damper for stabilizing power-electronics-based AC systems," *IEEE Trans. Power Electron.*, vol. 29, no. 7, pp. 3318-3329, Jul. 2014.
- [55] X. Wang, Y. Pang, F. Blaabjerg, and P. C. Loh, "A series-LC-filtered active damper systems," *IEEE Trans. Power Electron.*, vol. 30, no. 8, pp. 4037-4041, Aug. 2015.
- [56] Y. Yang, H. Wang, F. Blaabjerg, and T. Kerekes, "A hybrid power control concept for PV inverters with reduced thermal loading," *IEEE Trans. Power Electron.*, vol. 29, no. 12, pp. 6271-6275, Dec. 2014.
- [57] A. Sangwongwanich, Y. Yang, and F. Blaabjerg, "High-performance constant power generation in grid-connected PV systems," *IEEE Trans. Power Electron.*, vol. PP, no. 99, pp.1-4, in press, doi: 10.1109/TPEL.2015.2465151, 2016.
- [58] A. Ahmed, L. Ran, S. Moon, and J.-H. Park, "A fast PV power tracking control algorithm with reduced power mode," *IEEE Trans. Energy Convers.*, vol. 28, no. 3, pp. 565-575, Sep. 2013.
- [59] M. Campbell, J. Blunden, E. Smeloff, and P. Aschenbrenner, "Minimizing utility-scale PV power plant LCOE through the use of high capacity factor configurations," in *Proc. of IEEE PVSC*, pp. 421-426, 7-12 Jun. 2009.
- [60] U.S. Energy Information Administration, "Levelized Cost of New Generation Resources in the Annual Energy Outlook 2013," [Online] Tech. Rep., Jan. 2013. Available: <http://www.eia.gov/>.