



AALBORG UNIVERSITY
DENMARK

Aalborg Universitet

Cost-Effective Mass Production of Mono Bucket Foundations

Nielsen, Søren A.; Ibsen, Lars Bo; Gres, Szymon

Publication date:
2015

Document Version
Publisher's PDF, also known as Version of record

[Link to publication from Aalborg University](#)

Citation for published version (APA):

Nielsen, S. A., Ibsen, L. B., & Gres, S. (2015). *Cost-Effective Mass Production of Mono Bucket Foundations*. Poster presented at EWEA 2015 Annual Event, Paris, France.

General rights

Copyright and moral rights for the publications made accessible in the public portal are retained by the authors and/or other copyright owners and it is a condition of accessing publications that users recognise and abide by the legal requirements associated with these rights.

- ? Users may download and print one copy of any publication from the public portal for the purpose of private study or research.
- ? You may not further distribute the material or use it for any profit-making activity or commercial gain
- ? You may freely distribute the URL identifying the publication in the public portal ?

Take down policy

If you believe that this document breaches copyright please contact us at vbn@aub.aau.dk providing details, and we will remove access to the work immediately and investigate your claim.

Abstract

Today, the basis for design and manufacturing of offshore foundations is inherited from oil and gas industry where the small repeatability in manufacturing is the case and the cost implications are different. The total opposite is the case when considering offshore Wind Turbine Generator foundations where mass production is needed.

The project is planned for a duration of 3 years and is supported by **Innovation Fund Denmark** and has the following partners: **DTU Wind Energy, FORCE Technology, LIC Engineering, AAU Civil and M-tech**. The € 4 mill. project involves more than 25 researchers, Ph.D.'s and developers.

Objectives

In order to design a cost-optimal foundation for offshore wind farms it is necessary to consider all the involved phases: **Design, Production, installation.**

The objective of the project is to develop an integrated and iterative analysis process for design of the support structure with the aim to achieve low weight as well as ability to be **designed, fabricated and installed by standardized and automated processes** where ever possible.

At the same time, the foundation structure shall have **discrete parametric properties** so that it is easy to alter a **'basic' foundation design** for different environmental conditions, water depth, soil properties and for different wind turbines.

The foundation has to be cost efficient to install with few offshore operations – **No seabed preparation and no or reduced need of scour protection and no noise issues.**

The overall goal is to introduce a framework for Mono Bucket Foundation design, which can lead to mass customization/production and industrialization recognised by the main costumers and the certifying authorities.

Innovative Design Approach: In-house software and commercial FEM-software

4) Geotechnical design: Calculation of bucket size.

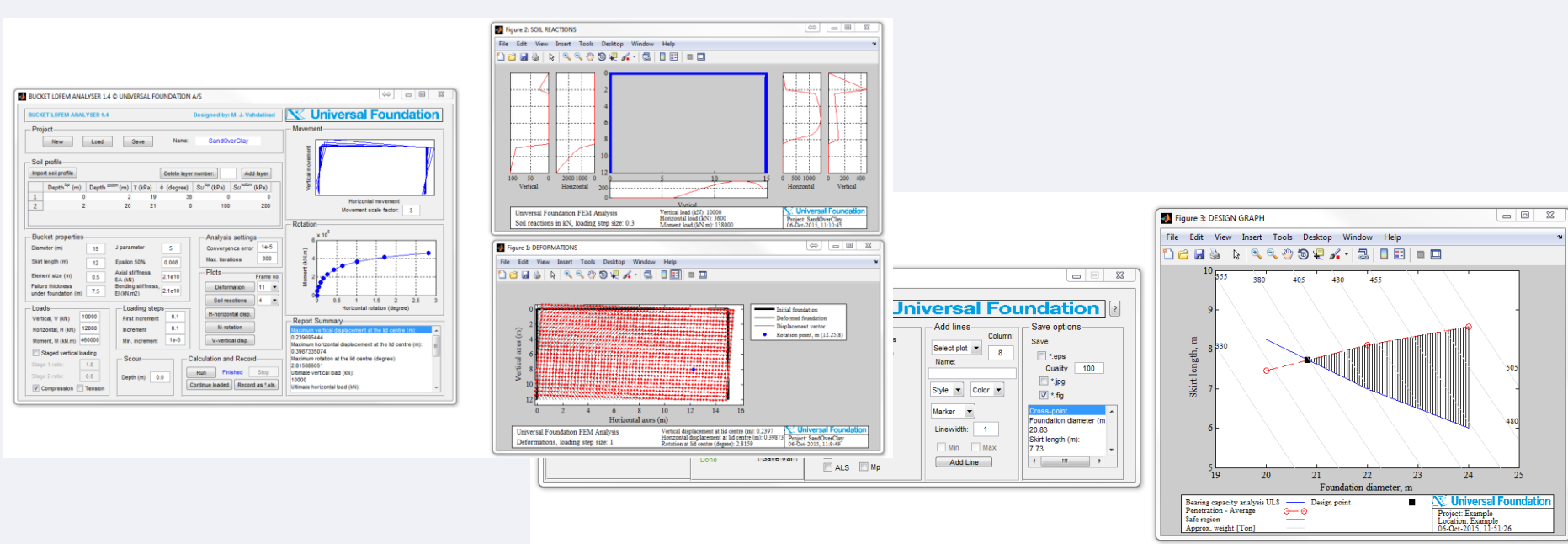

3) Steel Structure design: Calculation of shaft.

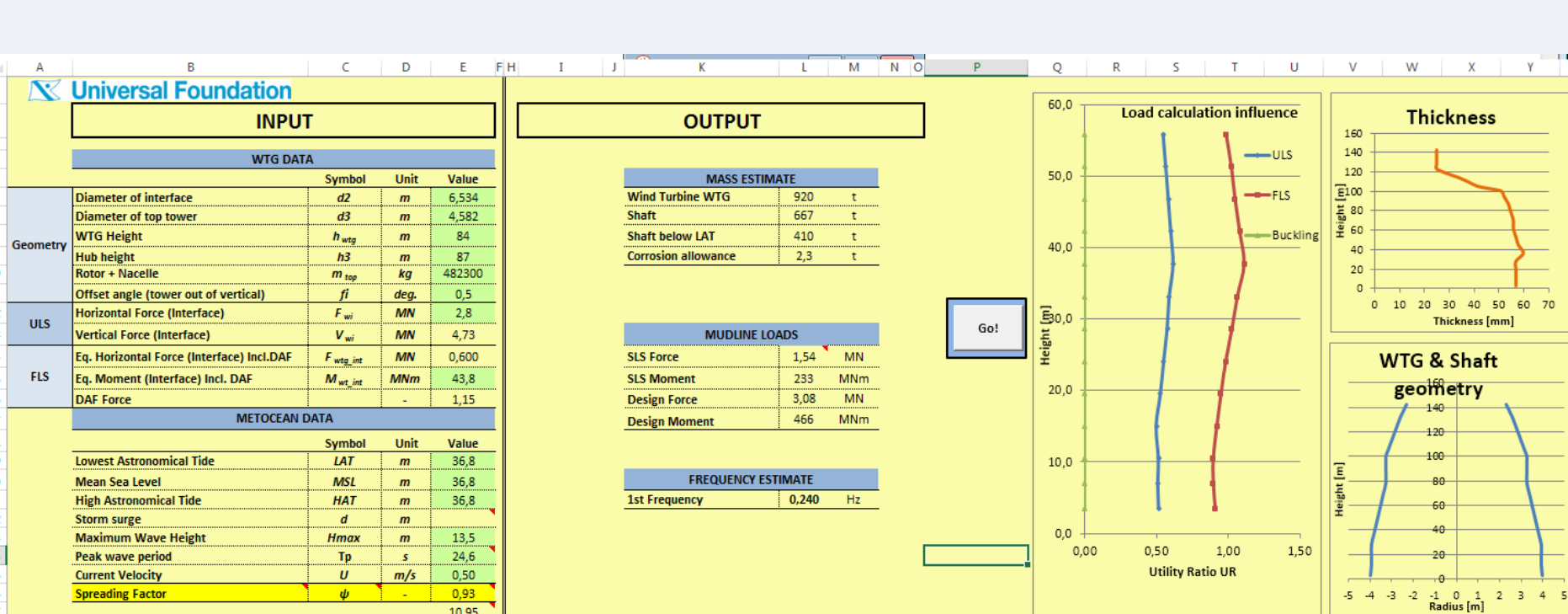

2) Load estimation: Wave load dynamics.

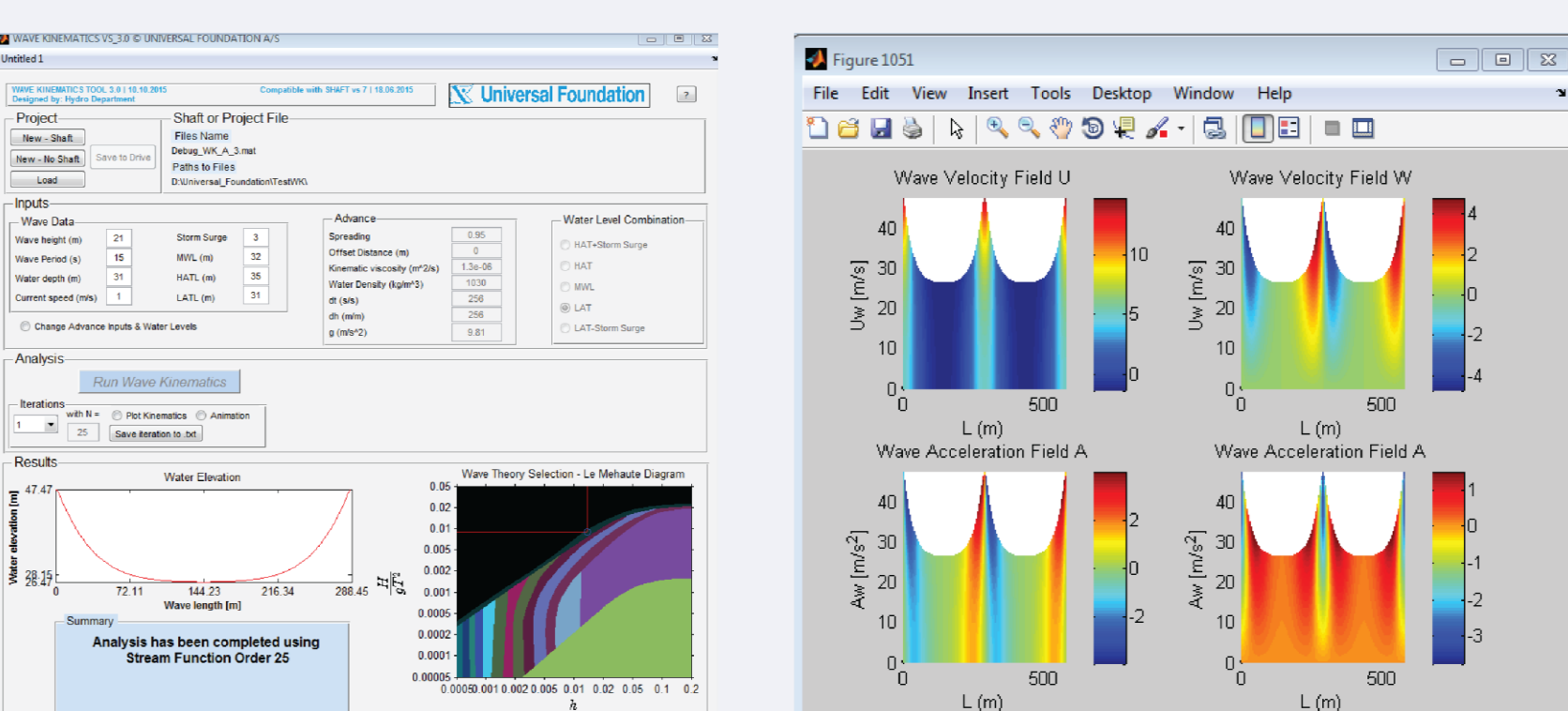

1) Geotechnical design: CPT interpretation.

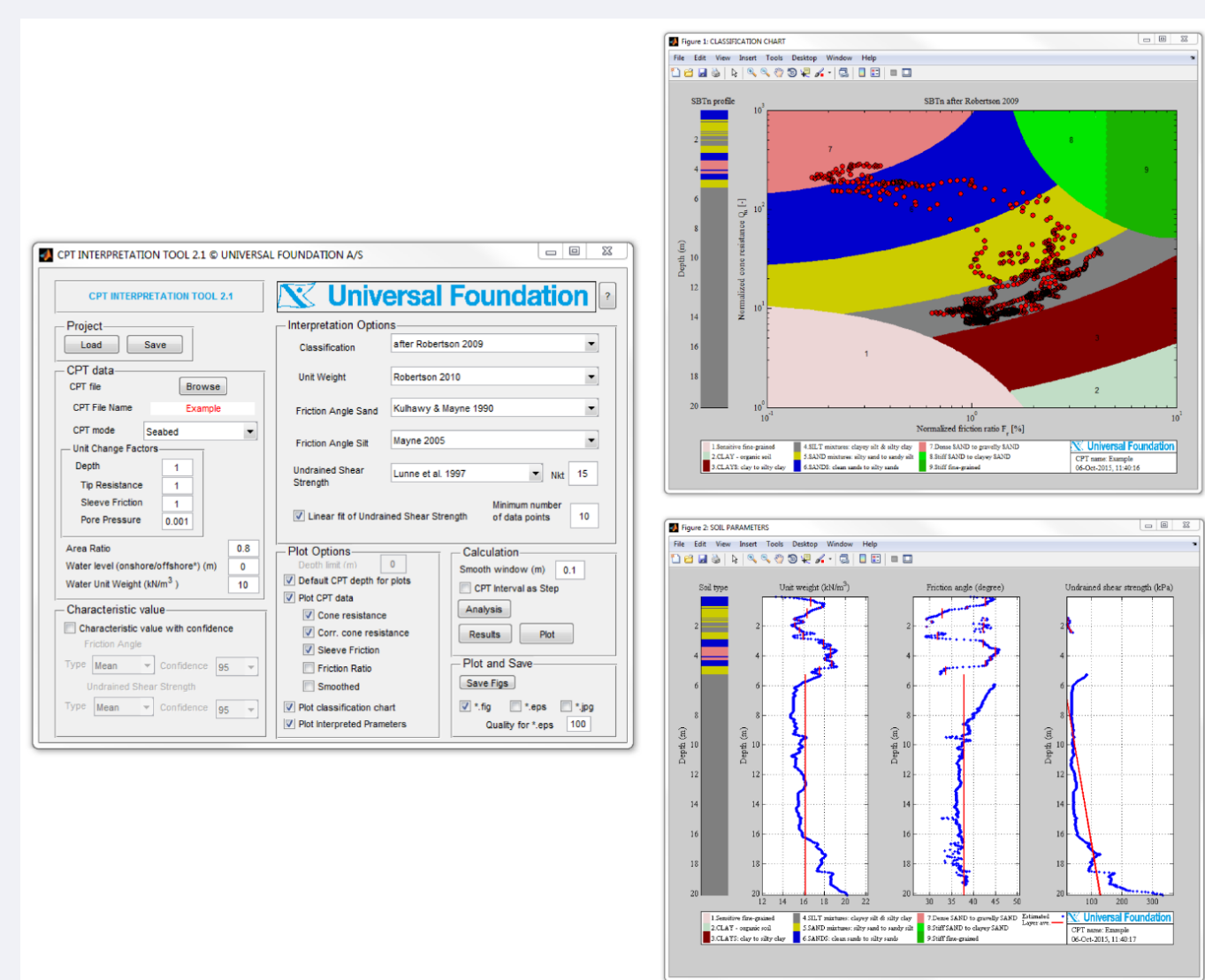

5) Steel structure design: Bucket details and detailed FEM model.

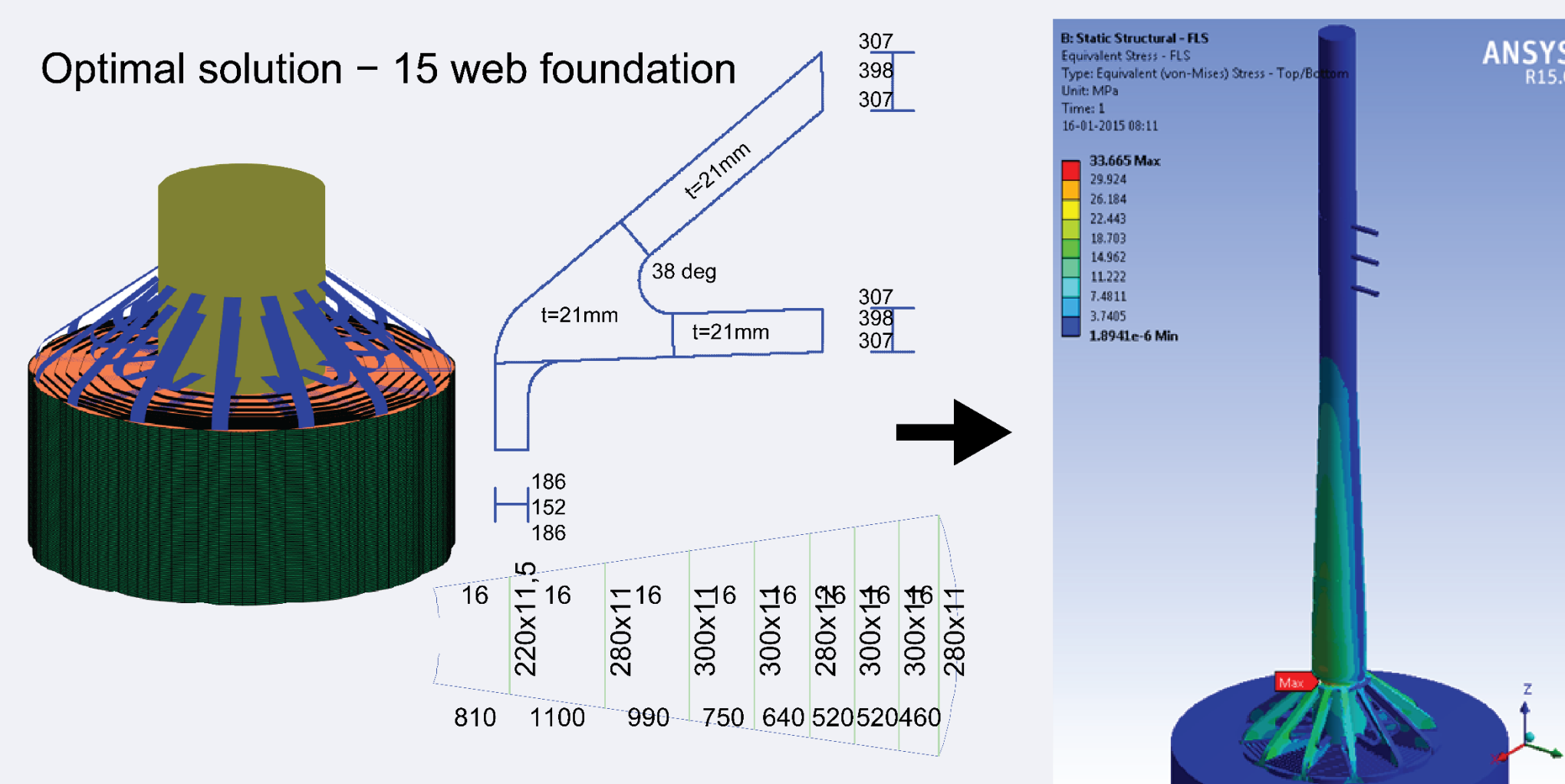

6) Configuration of the individual foundation.

- Intelligent SIM (Structure Information Modelling).
- Interlinked numerical FE-model with 3D CAD model.
- Technical documentation and drawings generation.

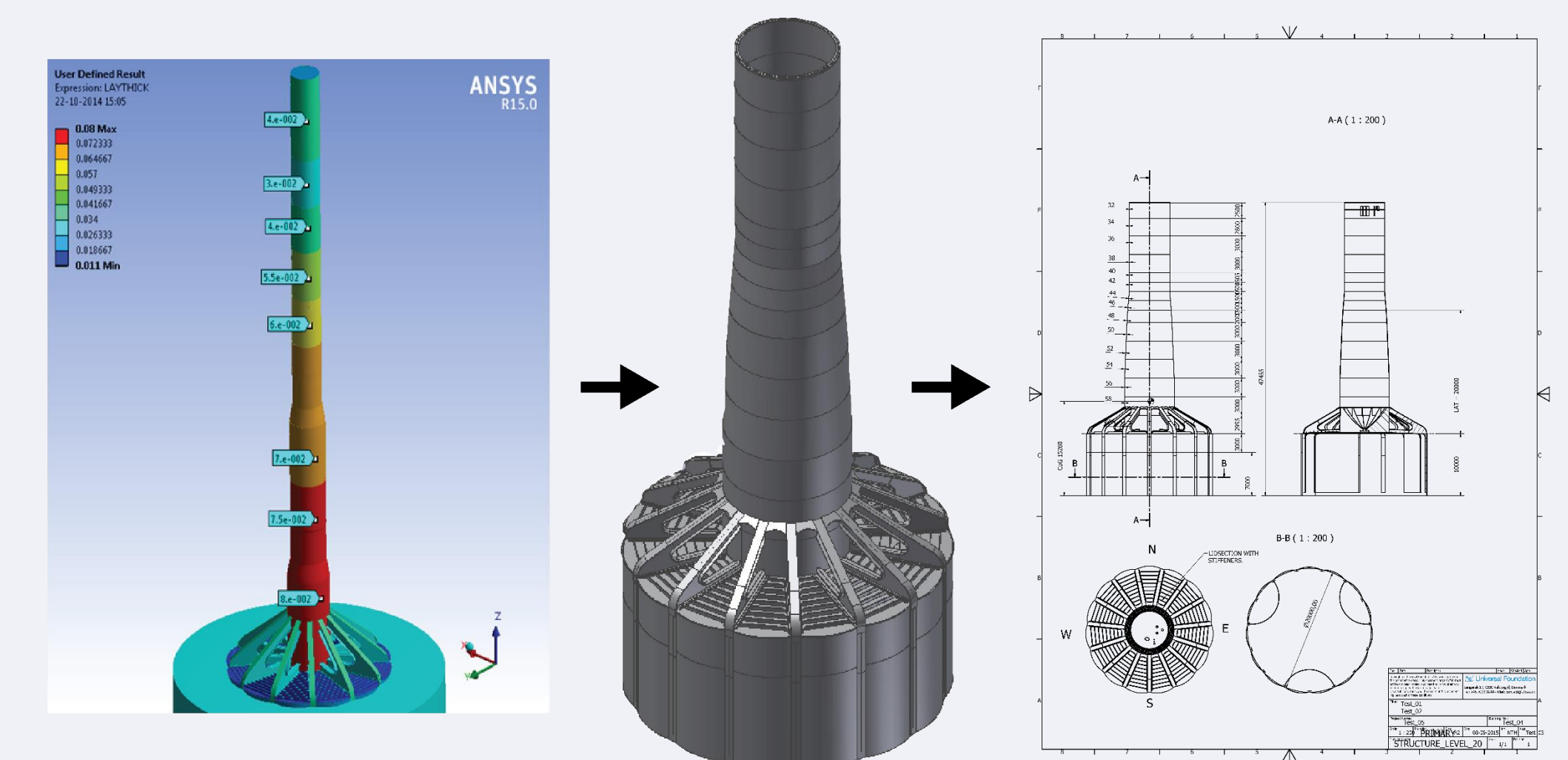

7) Manufacturing.

- Modular production process.
- Automated welding prepared for high input laser technology.

8) Logistics.

- Transport/ installation using DP2 or jack-up vessel.
- Alternative self-float towing and buoyant up-ending.

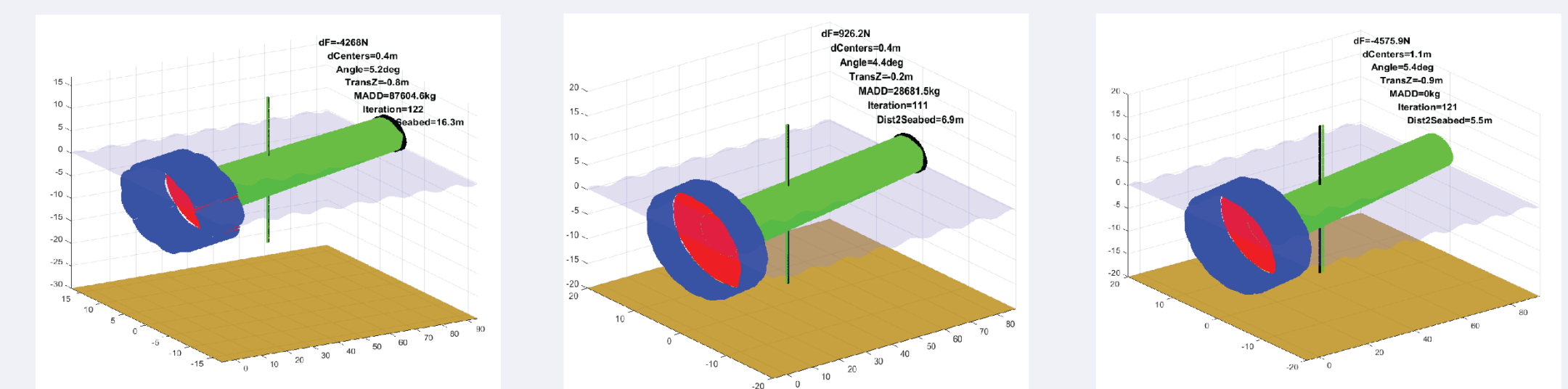

9) Installation.

- CPT based penetration analyses.
- Noise free operation.
- Integrated scour design.
- Integrated seabed levelling.

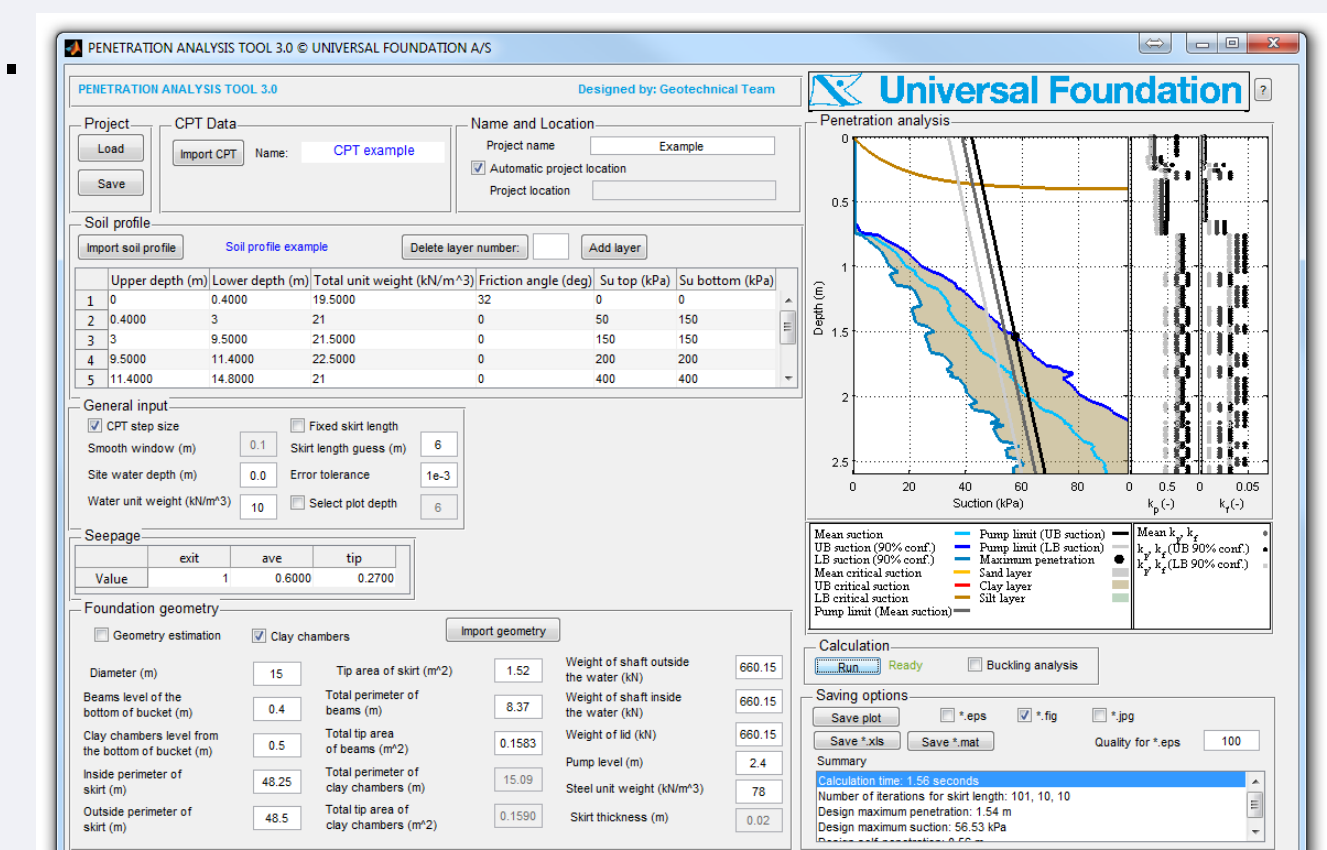

10) Offshore operation with limited vessel spread.

- Comprehensive Risk Assessment/Method Statement.

← 11) Lessons Learned – Feed Back.

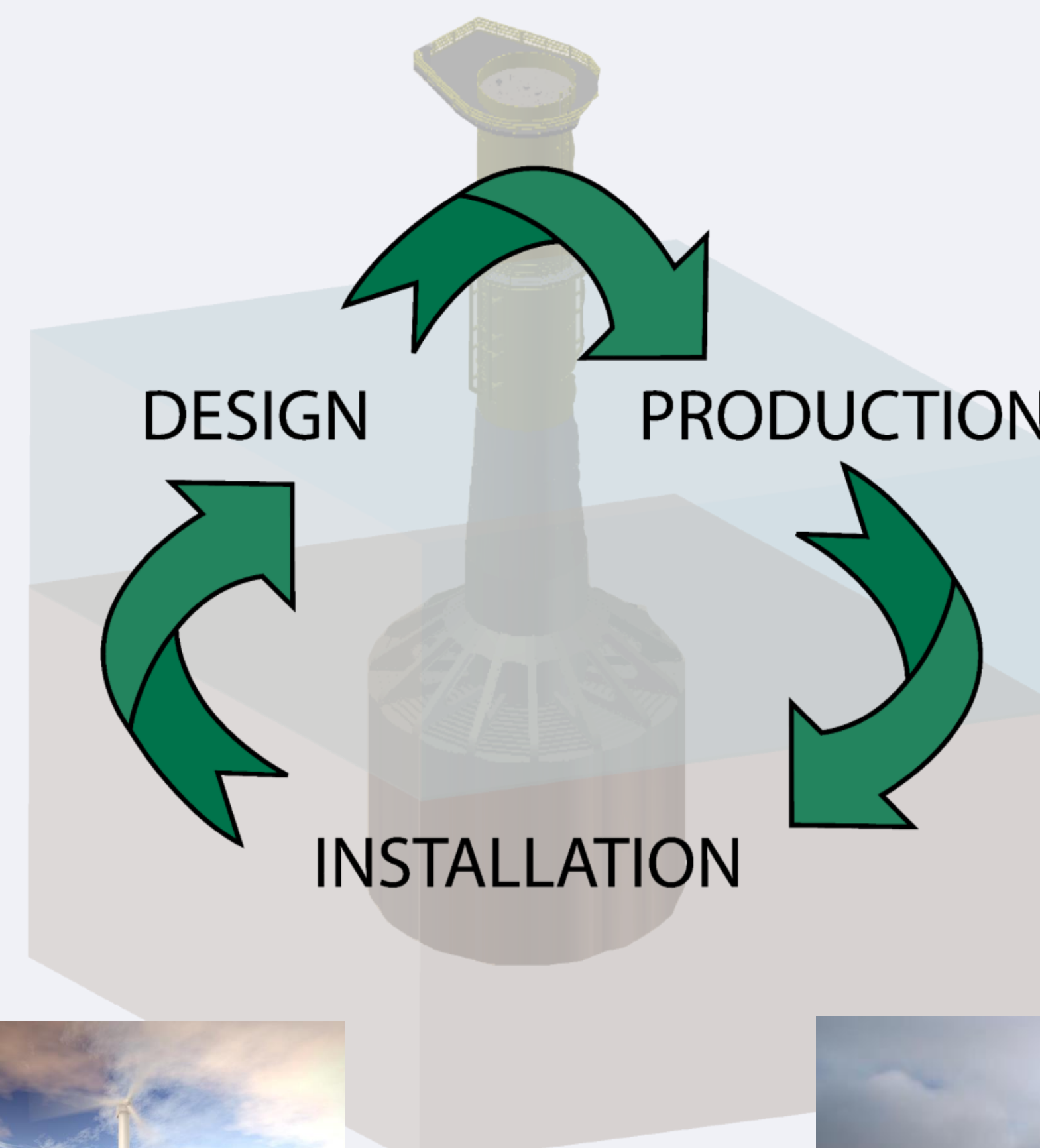

Conclusions

The Design Configurator is an advanced optimization software framework coupling the developed models and analysis techniques with robust and efficient numerical optimization methods for initial detail design process and for detailed structural optimization. The optimal design execution include wind and wave loads estimation, soil/structure interaction models and manufacturing / installation cost models. The Design Configurator is powerful enough to perform accurate optimal design of the individual foundations in an entire large scale offshore wind turbine farm.

Learning objectives.

The increase in project sizes, an increased demand for reliable project execution across the supply chain and the general cost-out requirement make innovative initiatives with a high standardization and automation potential highly valued by customers and absolutely imperative to the competitiveness of offshore wind energy.

Contact information: www.universal-foundation.com