



**AALBORG UNIVERSITY**  
DENMARK

**Aalborg Universitet**

## **Voltage Harmonics Monitoring in a Microgrid Based on Advanced Metering Infrastructure (AMI)**

Savaghebi, Mehdi; Guan, Yajuan; Quintero, Juan Carlos Vasquez; Guerrero, Josep M.; Nielsen, Carsten

*Published in:*

Proceedings of the Seminario Anual de Automática, Electrónica Industrial e Instrumentación 2015 (SAAEI'15)

*Publication date:*  
2015

*Document Version*  
Early version, also known as pre-print

[Link to publication from Aalborg University](#)

*Citation for published version (APA):*

Firoozabadi, M. S., Guan, Y., Quintero, J. C. V., Guerrero, J. M., & Nielsen, C. (2015). Voltage Harmonics Monitoring in a Microgrid Based on Advanced Metering Infrastructure (AMI). In Proceedings of the Seminario Anual de Automática, Electrónica Industrial e Instrumentación 2015 (SAAEI'15)

### **General rights**

Copyright and moral rights for the publications made accessible in the public portal are retained by the authors and/or other copyright owners and it is a condition of accessing publications that users recognise and abide by the legal requirements associated with these rights.

- ? Users may download and print one copy of any publication from the public portal for the purpose of private study or research.
- ? You may not further distribute the material or use it for any profit-making activity or commercial gain
- ? You may freely distribute the URL identifying the publication in the public portal ?

### **Take down policy**

If you believe that this document breaches copyright please contact us at [vbn@aub.aau.dk](mailto:vbn@aub.aau.dk) providing details, and we will remove access to the work immediately and investigate your claim.

# Voltage Harmonics Monitoring in a Microgrid Based on Advanced Metering Infrastructure (AMI)

Mehdi Savaghebi, *Member, IEEE*, Yajuan Guan, *Student Member, IEEE*, Juan C. Vasquez, *Senior Member, IEEE*, Josep M. Guerrero, *Fellow, IEEE*, and Carsten Nielsen

**Abstract**—Smart meters are the main part of Advanced Metering Infrastructure (AMI) and are usually able to provide detailed information on customers' energy consumptions, voltage variations and interruptions. In addition, these meters are potentially able to provide more information about power quality (PQ) disturbances. This paper will address the monitoring of voltage harmonics utilizing the features of smart meters and AMI system. To do this, the first step is to select proper indices to quantify the distortion. An important point which should be considered in this regard is the limited processing power of smart meters in comparison with PQ Analyzers (PQAs). Furthermore, the indices are categorized as site and system indices. The site indices measure the distortion at one metering section while the system indices provide a PQ view in an area encompassing multiple meters. In addition, the smart metering system which is implemented in Intelligent Microgrid Lab of Aalborg University (AAU) will be introduced.

**Index Terms**—Advanced Metering Infrastructure (AMI), Power quality indices, Smart meter, Voltage harmonics.

## I. INTRODUCTION

ADVANCED Metering Infrastructure (AMI) consists of smart meters and data storage, management and communication systems. Smart meter (SM) is one of the most important devices in smart grid (SG). The smart meter is an advanced energy meter that collects information from the end users' load devices and measures the energy consumption of the consumers as well as the generating power of the distributed generation system. The SM provides real-time information to the utility company and/or system operator. Several sensors and control devices, supported by dedicated communication infrastructure, are utilized in a smart meter [1]-[3]. Fig. 1 shows the metering architectures comparison of a conventional electrical meter and a smart meter.

On the other hand, proliferation of nonlinear loads in recent years has increased the voltage harmonics distortion especially in low-voltage distribution networks. Thus, power quality (PQ) monitoring to ensure proper operation of the system is of

great importance. In order to perform PQ surveys, it is possible to apply fixed and/or portable PQ analyzers (PQAs). PQAs are able to provide detailed data of various PQ phenomena. However, installation of fixed PQAs necessitates a large investment while portable ones can only provide the PQ data during the monitoring period. In this regard, smart meters can provide PQ monitoring among their other capabilities [4]-[6]. PQ data recorded by these meters are not as exact as PQAs recordings, but are provided continuously and at approximately no additional cost. Furthermore, AMI system abilities for data communication, processing and management can be effectively applied in PQ applications. Based on this, overall evaluation of PQ in an area encompassing a large number of meters will be possible. Thus, research for extending the use of smart meters for PQ monitoring will present noticeable technical and economic benefits.

## II. SMART METERING SYSTEM IN AALBORG UNIVERSITY (AAU) INTELLIGENT MICROGRID LAB

In order to implement the smart meter system, realize the 2-way communication between Smart meters and data collector, 12 smart meters are installed in AAU Microgrid Lab. Some tests have been done based on different series of smart meters and different communication technologies.

### A. Configuration

The Intelligent Microgrid laboratory in AAU is based on 6 workstations. Each workstation includes four DC-AC converters, LCL-filters, ABB Motorized change-over switches and two Kamstrup Smart-meters, as depicted in Fig. 2. Fig. 3 shows the configuration and electrical structure of each workstation. It is can be seen, the Kamstrup 351B industrial smart meter is used to measure the total generating power of the workstation (can be regarded as a DG system) and Kamstrup 382L residential smart meter measures one of the load consumption (can be regarded as one building).

### B. Communication

Smart Metering Systems are varied based on different technology and design, but operate through a simple overall process. Smart Meters collect data from the end consumers and transmit this data information through the Local Area Network (LAN) to the data collector. This transmission

This work was supported by the Energy Technology Development and Demonstration Program (EUDP) through the Sino-Danish project "Microgrid Technology Research and Demonstration" (meter.et.aau.dk)

M. Savaghebi, Y. Guan, J. C. Vasquez and J. M. Guerrero are with the Dept. Energy Tech., Aalborg University, Denmark (e-mail: {mes, ygu, juq, joz}@et.aau.dk).

C. Nielsen is with Kamstrup A/S, Denmark (email: can@kamstrup.dk).

process can be executed every 15 minutes or other slower frequency based on the requirement of the data demand. After that the collector retrieves the data and then transmits it. The utility central collection points further processes the data by using the Wide Area Network (WAN). Since the communications path is two-way, signals or commands can be sent directly to the meters, customer premise or distribution device.

communication technologies are employed by now: Optical head and the Internet-based on TCP/IP. Some tests have been done based on these to communication methods. There are also some other communication technologies used for smart meter system based smart grid, such as radio mess, power line carrier (PLC), Zigbee, 3G, GPRS and so on. In smart grid applications, there are different advantages and disadvantages associated with them. The utilities choose the best technology based on their business profits and real implementation [7].

In MG Lab, two basic types of smart meter system

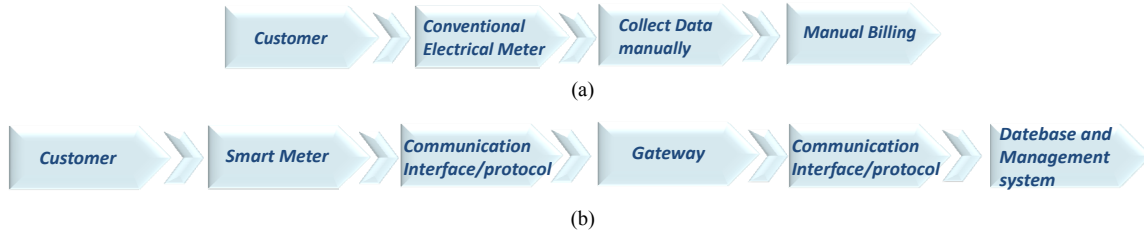

Fig. 1. Metering architectures comparison: (a) Conventional electrical meter, (b) Smart meter.

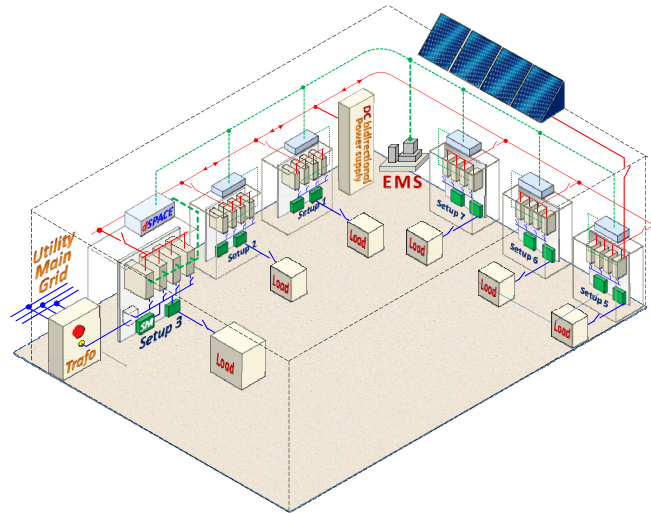

Fig. 2. Overview of intelligent MG Lab.

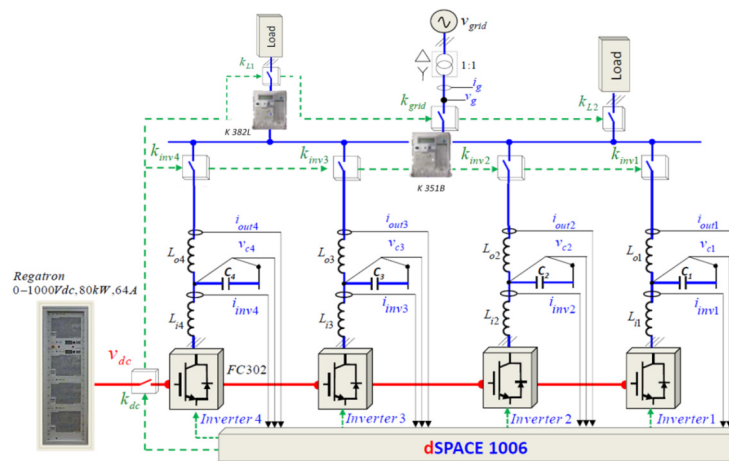

Fig. 3. Configuration of each setup.

### C. Kamstrup OMNIA System

OMNIA Suite is an AMI system which includes smart meters, network communication, meter data management and smart grid features tailored to the business of utilities today, as shown in Fig. 4. In a near future, OMNIA suite will be deployed in AAU Intelligent MG Lab, which will make the Lab like a simulated smart grid platform. The general scheme of this smart MG Lab is shown in Fig. 5. As depicted in the figure, this Lab will include the OMNIPOWER smart meters, OMNICON as data concentrator, utilidriver to integrate the SM and the data management system (VisionAir) and energy management system produced by AAU MG group. The In-house display system will also be included in this Lab.

This smart MG Lab can provide possibilities for substation monitoring, voltage quality profiles like Total Harmonic Distortion (THD) from each metering point. Thus, it helps to give the grid owner a unique insight into the distribution system. The enhanced intelligence in meters and concentrators will provide quick responses as well as a high data frequency from the low voltage grid. It can also provide load control outputs for demand-side programs and load shedding on-demand.

### III. AMI-BASED VOLTAGE HARMONIC MONITORING

The first step toward voltage harmonic distortion in an AMI system is to define proper quantifying indices. These indices are studied in this section in two categories, namely, site indices and system indices. The site indices measure the distortion at one metering section (smart meter) while the system indices provide a PQ view of a system (e.g. microgrid) encompassing multiple meters. System indices are conceived to be calculated in power quality application of central software package of Meter Data Management (MDM) unit which can be seen in Fig. 4.

#### A. Site Indices

THD is the most important harmonic index and can be calculated as follows [8]:

$$THD = \sqrt{\frac{\sum_{h=2}^{50} V_h^2}{V_1}} \quad (1)$$

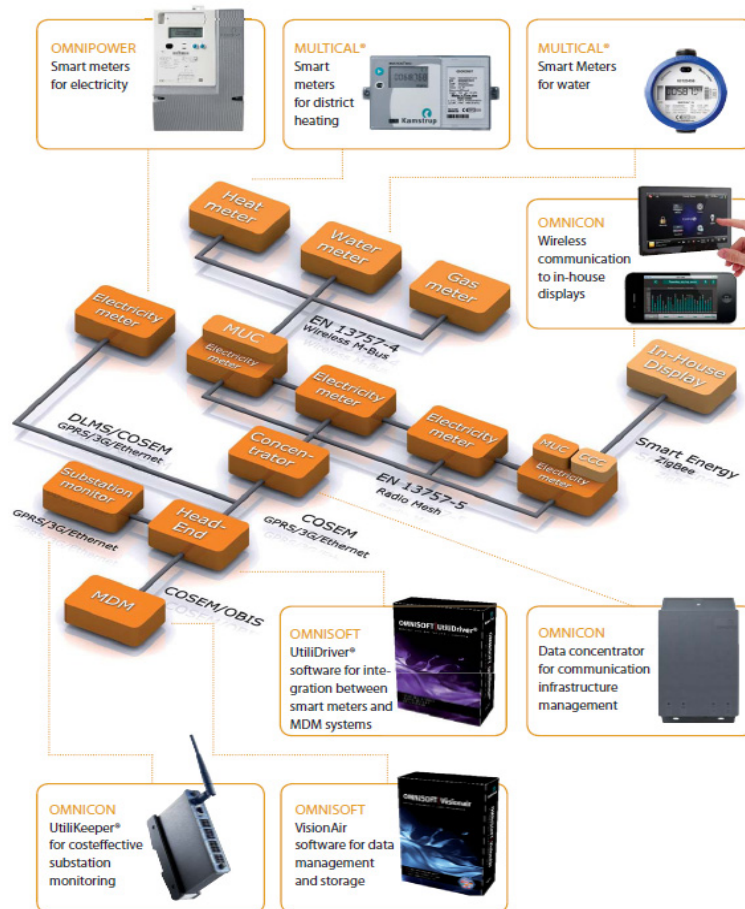

Fig. 4. Configuration of Kamstrup OMNIA system

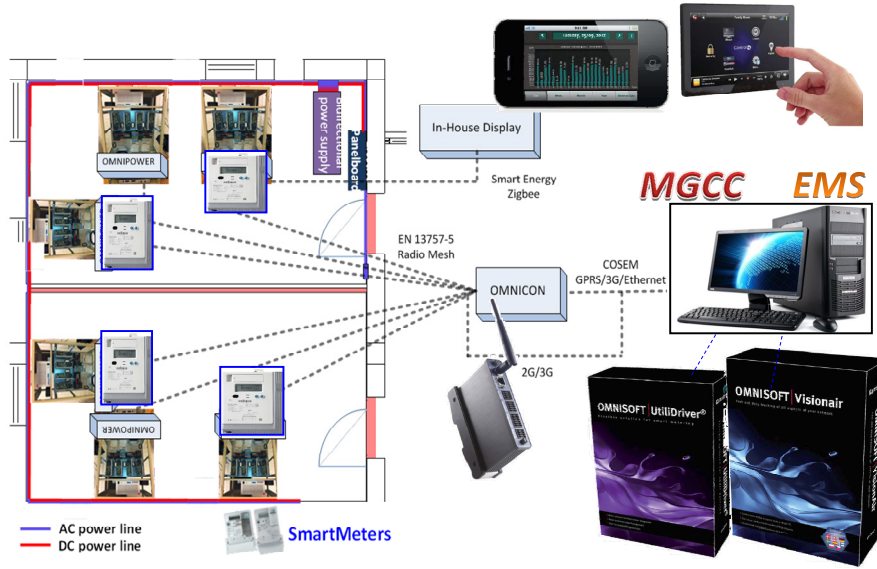

Fig. 5. Configuration of Intelligent Microgrid Lab combined with Kamstrup OMNIA system.

In IEC 61000-2-4 [9] and IEC 61000-3-6 [10], it is suggested to consider up to 40<sup>th</sup> or 50<sup>th</sup> harmonic order for THD calculation, but, when there is a low chance for harmonic resonance, it is allowed to limit the calculation to 25<sup>th</sup> harmonic [11].

Some statistical harmonic indices proposed in different standards can be summarized as following [12]:

- Daily 99% (or other percentile, e.g. 95%) of very short term (calculated over 3 sec) individual harmonic indices (per unit value of individual harmonics with rated voltage base) or THD values. Daily 99% percentile is a value that only 1% of very short term indices exceed that.
- Weekly 95% (or other percentile) of short term (calculated over 10 min) individual harmonic indices or THD values.
- Weekly peak value of individual or total harmonic distortion values

It should be noted that very short term and short term indices are calculated based on time aggregation process which is explained in [12].

A problem which may arise in the case of harmonic distortion is the excessive peak voltage which may result in dielectric stress. Crest Factor (CF) is an index which quantifies this phenomenon. CF is defined as the ratio of voltage peak to rms values [13].

There are some other indices which measure the interference in communication wires and telephone system due to voltage and/or current harmonics. Among others, Telephone Influence Factor (TIF), IT product and C message index [13] can be mentioned. However, nowadays, these indices are not practical as a result of effective shielding and noise control methods.

### B. System Indices

System indices can be directly calculated based on site indices, directly. The main system indices are summarized below [12]:

- System 95% THD (STHD95)
- System Average THD (SATHD)
- System Average Excessive Total Harmonic Distortion Ratio Index (SAETHDRI<sub>THD\*</sub>)

To define these indices, let us assume an electrical system (e.g. a microgrid) with  $M$  monitoring sites (smart meters). STHD95 is 95% percentile of a probability distribution. This distribution is formed based on 95% percentiles of  $M$  probability distributions [12], which each of them corresponds to one smart meter. SATHD is similar to SATHD, but, it is calculated by averaging individual 95% percentiles.

SAETHDRI<sub>THD\*</sub> shows the number of reported THD indices which exceed a threshold (THD\*) in a specific time interval like a day, week or month. Calculation of this index is initiated by counting the number of site THD samples (recorded hourly, for instance) which exceed THD\*. Then, this values is normalized over total THD samples in site  $s$  and finally, the weighted sum of these normalized values is extracted as follows [12]:

$$SAETHDRI_{THD*} = \frac{\sum_{s=1}^M L_s \left( \frac{N_{THD*s}}{N_{Tot,s}} \right)}{L_T} \quad (2)$$

In this equation,  $N_{THD*s}$  is the exceeding measured samples in site  $s$ ,  $N_{Tot,s}$  represents the total number of measurements,  $L_s$  is the kVA supplied in site  $s$  and  $L_T$  shows the total kVA supplied in under-study system (microgrid).

#### IV. CONCLUSION

This paper has been dedicated to evaluation and monitoring of power quality in microgrids which are equipped with AMI which is also called smart metering system. Some details regarding AMI implementation in AAU Intelligent Microgrid Lab is provided, firstly and then, proper indices are proposed to assess voltage harmonic, as a main PQ problem, in an AMI-based system. As the next steps, we are working on monitoring of various PQ phenomena (e.g. voltage unbalance, sag, swell, interruption) and finally, real implementation of a PQ monitoring system in a smartly metered microgrid.

#### REFERENCES

- [1] Z. Guo, Z. J. Wang, and A. Kashani, "Home appliance load modeling from aggregated smart meter data," *IEEE Trans. Power Sys.*, vol. 30, no. 1, pp. 254-262, Jan. 2015.
- [2] M. Tasdighi, H. Ghasemi, and A. Rahimi-Kian, "Residential microgrid scheduling based on smart meters data and temperature dependent thermal load modeling," *IEEE Trans. Smart Grid*, vol. 5, no. 1, pp. 349-357, Jan. 2014.
- [3] Z. Guo, Z. J. Wang, and A. Kashani "Smart meter driven segmentation: what your consumption says about you," *IEEE Trans. Power Sys.*, vol. 28, no. 4, pp. 4019-4030, Nov. 2013.
- [4] C. W. Liu, C. C. Lu, P. Y. Lin, and G. C. Lu, "Develop a power quality measurement system integrated with HAN home energy management system," in *Proc. 4<sup>th</sup> Int. Conf. Electric Util. Deregulation and Restructuring and Power Technologies (DRPT)*, Weihai, 2011, pp. 1506-1510.
- [5] S. Ali, K. Weston, D. Marinakis, W. Kui, "Intelligent meter placement for power quality estimation in smart grid," in *Proc. IEEE SmartGridComm.*, Vancouver, 2013, pp. 546-551.
- [6] M. Music, A. Bosovic, N. Hasanspahic, S. Avdakovic, and E. Becirovic, "Integrated power quality monitoring system and the benefits of integrating smart meters," in *Proc. 8<sup>th</sup> Int. Conf. Compatibility and Power Electron. (CPE)*, Ljubljana, 2013, pp. 86-91.
- [7] Y. Yan, Y. Qian, H. Sharif, and D. Tipper, "A survey on smart grid communication infrastructures: motivations, requirements and challenges," *IEEE Communications Surveys & Tutorials*, vol. 15, no. 1, pp. 5-20, First quarter 2013.
- [8] IEC 61000-3-12, Electromagnetic compatibility (EMC)–Part 3-12: Limits- Limits for harmonic currents produced by equipment connected to public low-voltage systems with input current >16A and <75A per phase.
- [9] IEC 61000-2-4, Electromagnetic compatibility (EMC)–Part 2-4: Environment-Compatibility levels in industrial plants for low-frequency conducted disturbances.
- [10] IEC/TR 61000-3-6, Electromagnetic compatibility (EMC)–Part 3-6: Limits – Assessment of emission limits for the connection of distorting installations to MV, HV and EHV power systems.
- [11] IEC 61000-2-2, Electromagnetic compatibility (EMC)–Part 2-2: Environment- Compatibility levels for low-frequency conducted disturbances and signaling in public low-voltage power supply systems.
- [12] P. Caramia, G. Carpinelli, and P. Verde, *Power quality indices in liberalized markets*, Wiley, 2009.
- [13] R. C. Dugan, M. F. McGranaghan, S. Santoso, and H. W. Beaty, *Electrical Power Systems Quality*, (2nd ed.), New York: McGraw-Hill, 2003.