



**Aalborg Universitet**

**AALBORG UNIVERSITY**  
DENMARK

## **Review of Power Sharing Control Strategies for Islanding Operation of AC Microgrids**

Han, Hua; Hou, Xiaochao; Yang, Jian; Wu, Jifa; Su, Mei; Guerrero, Josep M.

*Published in:*

I E E E Transactions on Smart Grid

*DOI (link to publication from Publisher):*

[10.1109/TSG.2015.2434849](https://doi.org/10.1109/TSG.2015.2434849)

*Publication date:*

2016

*Document Version*

Early version, also known as pre-print

[Link to publication from Aalborg University](#)

*Citation for published version (APA):*

Han, H., Hou, X., Yang, J., Wu, J., Su, M., & Guerrero, J. M. (2016). Review of Power Sharing Control Strategies for Islanding Operation of AC Microgrids. I E E E Transactions on Smart Grid, 7(1), 200 - 215. DOI: 10.1109/TSG.2015.2434849

### **General rights**

Copyright and moral rights for the publications made accessible in the public portal are retained by the authors and/or other copyright owners and it is a condition of accessing publications that users recognise and abide by the legal requirements associated with these rights.

- ? Users may download and print one copy of any publication from the public portal for the purpose of private study or research.
- ? You may not further distribute the material or use it for any profit-making activity or commercial gain
- ? You may freely distribute the URL identifying the publication in the public portal ?

### **Take down policy**

If you believe that this document breaches copyright please contact us at [vbn@aub.aau.dk](mailto:vbn@aub.aau.dk) providing details, and we will remove access to the work immediately and investigate your claim.

# Review of Power Sharing Control Strategies for Islanding Operation of AC Microgrids

Hua Han, Xiaochao Hou, Jifa Wu, Mei Su, Jian Yang, *Member, IEEE*, Josep M. Guerrero, *Fellow, IEEE*

**<sup>1</sup>Abstract**—Microgrid is a new concept for future energy distribution system that enables renewable energy integration. It generally consists of multiple distributed generators (DGs) that are usually interfaced to the grid through power inverters. For the islanding operation of AC microgrids, two important tasks are to share the load demand among multiple parallel connected inverters proportionately and maintain the voltage and frequency stabilities. This paper reviews and categorizes various approaches of power sharing control principles. Simultaneously, the control schemes are graphically illustrated. Moreover, various control approaches are compared in terms of their respective advantages and disadvantages. Finally, the paper presents the future trends.

**Index Terms**— AC microgrid; power electronic inverters; power sharing control strategies; islanding operation

## I. INTRODUCTION

WITH the expansion of the electrical power grid, conventional power system has become increasingly vulnerable to cope with the reliability requirements and the diverse demand of power users. Moreover, Distributed generation (DG) has advantages of pollution reduction, high energy utilization rate, flexible installation location, and low power transmission losses. DG units also present a higher degree of controllability and operability compared to the conventional generators [1], which will allow microgrids to play a major and critical role in maintaining the stability of electrical networks [2]-[4]. So, microgrids will gradually be a strong and effective support for the main power grid and potentially one of the future trends of power system [5].

The DG units of a microgrid can be classified into grid-forming (voltage-controlled) and grid-following (current controlled) DG units [6]. In grid-connected mode, the units are often controlled as grid-following. The most adopted control strategies for grid-following inverters are discussed in [4], [7], [8]-[9]. In islanding mode, the electronic converter interfaces between the loads and the micro-sources act as voltage sources, which are responsible for the power sharing according to their ratings and availability of power from their corresponding energy sources or prime movers [10]-[15].

Manuscript received September 14, 2014; revised October 16, 2014 and March 30, 2015; accepted for publication May 04, 2015. This work was supported by the National Natural Science Foundation of China under Grants 61174125 and 61203031.

H. Han, X. Hou, J. Wu, M. Su, and J. Yang (corresponding author) are with the School of Information Science and Engineering, Central South University, Changsha 410083, China (e-mail: jian.yang@csu.edu.cn).

J. M. Guerrero is with the Department of Energy Technology, Aalborg University, Aalborg 9220, Denmark (e-mail: joz@et.aau.dk).

This paper focuses on control strategies of grid-forming DG units in islanding mode. Researches on control of grid forming units were performed initially in uninterruptible power supply (UPS) systems with parallel operation [16]-[21]. Power sharing control strategies of DG units based on communication include concentrated control [22]-[27], master/slave control [28]-[31], and distributed control [24], [32], [33]. On the other hand, the control strategies without communication are generally based on the droop concept, which include four main categories: conventional and variants of the droop control [16], [34]-[60], virtual framework structure based method [6], [19], [53], [61]-[68], "construct and compensate" based methods [69]-[76] and the hybrid droop/signal injection method [36], [77]. The details and characters of various control methods will be illustrated later.

Integrated control strategies refer to hierarchical structures which usually consist of primary, secondary and tertiary control [22], [61], [62], [78]. The primary control stabilizes the voltage and frequency and offers plug-play capability for DGs. The secondary control, as a centralized controller, compensates for the voltage and frequency deviations to enhance the power quality. Tertiary control considers the optimal power flowing of the whole microgrids or interaction with main grid [12]. In addition, Hierarchical control has other special functions: distributed intelligent management system [79]; voltage unbalance compensation for optimal power quality [80]; self-healing networks [81]; smart home with a cost-effective energy ecosystem [82]; generation scheduling [83]. So, the hierarchical structure of microgrids can be regarded as an intelligent, integrated and multi-agent system.

Some reviews of microgrid control have been published recently [84]-[87]. Reference [84] classifies all the control strategies (e.g., decentralized control, centralized control, model predictive control, multi-agent systems,) into three levels: primary, secondary and tertiary based on their speed of response and infrastructure requirements. The most excellent is that it proposes the future challenges and trends in microgrid control. In [85], the next generation power system might adopt the distributed control techniques because of dividing the control task among different units. The characters of the distributed control are to use extensive integrated communication and advanced components. New family of microgrid control and management strategies realizes the plug and play concept and the dynamics of the frequency in [86]. Reference [87] discusses the control methods and objectives from the point of the voltage and frequency stability, and presents the factors affecting power load sharing. This paper focus on the inverter output control and power sharing control

which mostly belong to the primary control, especially for the droop-based control. Mostly, the decentralized control strategies are classed into four main categories more exactly.

The rest of the paper is organized as follows: Section II discusses three control methods based on communication. Section III presents the droop control methods, including the different variations. Section IV introduces several virtual structures techniques. Section V shows some “construction and compensation” methods. Hybrid droop/signal injection based methods are reviewed in Section VI. Then, characters of various methods and the future trends are summarized in Section VII. Finally, this paper concludes in Section VIII.

## II. COMMUNICATION BASED CONTROL TECHNIQUES

Communication based control techniques can achieve excellent voltage regulation and proper power sharing. Moreover, in contrast to droop controllers, which will be discussed later, the output voltage amplitude and frequency are generally close to their ratings without using a secondary control [22]. However, these control strategies, which require communication lines between the modules, result in increased cost of the system. Long distance communication lines will be easier to get interfered, thus reducing system reliability and expandability. In the following Section, several typical communication based control strategies are reviewed.

### A. Concentrated Control

The concentrated/central control method is presented in [23]-[27], [88], and the control scheme is illustrated in Fig. 1. The control method requires common synchronization signals and current sharing modules. The phase locked loop (PLL) circuit of each module can ensure the consistency between the frequency and phase of the output voltage and the synchronization signal. Also, the current sharing modules can detect the total load, which define the reference value of the current for each module. This reference current  $i_{ref}$  is a fraction of the load current  $i_{load}$ . For  $N$  equal modules,  $i_{ref} = i_{load}/N$ . In the meantime, every inverter unit measures itself output current in order to calculate the current error. In case of parallel units controlled by synchronization signals, they have negligible differences of frequency and phase among each other, thus the current sharing error of each unit can be caused by voltage amplitude inaccuracies. Therefore, this method directly adds current error to each inverter unit as a compensation component of the voltage reference in order to eliminate the differences among their output currents.

In [26] and [27], the central limit control (CLC) scheme is discussed. In CLC mode, all the modules should have the same configuration and each module tracks the average current to achieve equal current distribution. Reference [88] proposes a multistage centralized control scheme with high penetration of plug-in electric vehicles. The coordination allows the PEVs to play a pivotal role in the successful and optimized operation of the islanded microgrids.

The one advantage of the concentrated method is that current sharing is maintained during both steady-state and transients. However, this control scheme must include a

centralized controller, which makes difficult to expand the system and reduces system redundancies. Moreover, current reference has to be distributed to all converters by using high bandwidth communication links, in order to achieve synchronization among the units. These techniques present high dependency on communications and reduce the reliability, which may be compromised with single-point faults.

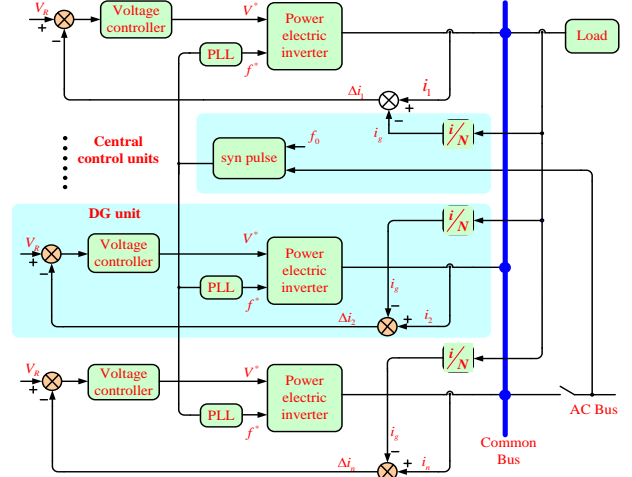

Fig. 1. Control schematic of the concentrated control.

### B. Master/Slave Control

Based on the master/slave control method, the function of parallel control units is built into each inverter. Through the mode-selecting switch or automatic software setting, the initially starting module in parallel acts as master inverter, which is in charge of parallel control, while the others serve as slave-inverters [28]-[31],[89]. The structure of “master/slave” control is illustrated in Fig. 2. As shown in this figure, the master module regulates the output voltage and specifies the current reference of the rest of slave modules. Then, slave units track the current reference provided by the master in order to achieve equal current distribution. Inverters don’t need any phase locked loop for synchronization since these units are communicated with the master units. However, the system isn’t redundant since it presents a single point of failure. If master unit fails, the whole system will fail.

In order to overcome this drawback, several researchers have improved the master/slave control method. In [30], the rotating priority window, providing random selection of the master, is proposed to increase the reliability. An auto master-slave control strategy is proposed in [31], which is a variant of the master/slave control. The control circuitry contains an active power share bus and a reactive power share communication bus interconnecting all the paralleled units. The inverter with the highest output power becomes the master inverter, which drives the power bus. Also, its power is the reference for the other inverters. The master-slave control in [89] regards the utility interface as master control at the common coupling point with the utility and the energy gateways, allows plug-and-play integration of DERs and ensures efficient and reliable operation of the microgrid in every operating condition.

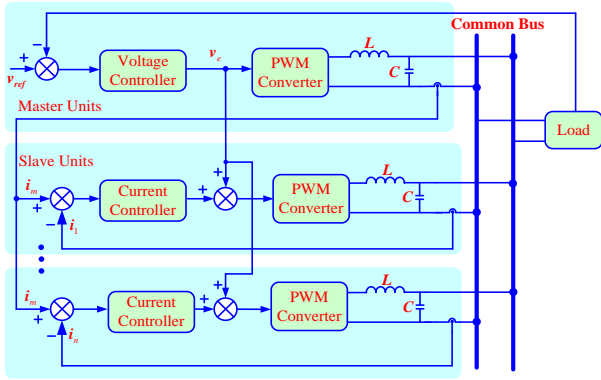

Fig. 2. Control structure of the master/slave control.

In summary, master/slave control can achieve excellent power sharing performance with advantages of ease implementation. If the master inverter fails, the improved control strategy would switch to another normal inverter which is then used as the new master. Therefore, parallel operation wouldn't be affected. However, an obvious issue with all master/slave control methods is that high output current overshoot may occur during transients since the master output current isn't controlled, so it doesn't ensure a good transient performance.

### C. Distributed Control

The distributed control is often applied to parallel converters [24], [32]-[33], [90]-[93]. The instantaneous average current sharing is a typically distributed control for parallel converters. In this control technique, individual control circuit is used in each inverter, but no central controller is needed. Further, average current sharing requires a current sharing bus and reference synchronization for the voltage. An additional current control loop is used to enforce each converter to track the same average reference current, provided by the current sharing bus. When a defect happen in any module, it can smoothly detach from the microgrid, and the rest of modules can still operate normally in parallel. Fig. 3 shows a control block diagram of the distributed control scheme. The average current sharing bus value is regarded as a current reference of each paralleled converter. The current error  $i_{en}$  is decomposed into active and reactive components,  $i_{end}$  and  $i_{enq}$ , then the output voltage frequency and amplitude are regulated through current regulators respectively.

The distinct feature of the distributed control is that the information required is not global but adjacent for any units. So it only needs lower band-width than the central control method. Because of dividing the control task among different units, it has many advantages compared to the droop control. Recently, it has become the flexible and reliable control strategies of future trends. In [90], a distributed networked control system is used to restore the frequency and amplitude deviations and ensure reactive power sharing. Without relying on a central control, the failure of a single unit won't influence the normal operation of the whole system. Reference [91] provides a distributed two-layer control scheme for ac microgrids. The voltage/frequency and active/reactive powers are decoupled, regulated by the first and second layers respectively. Reference [92] utilizes the fully distributed

control scheme for frequency restoration and economic dispatch. The most advantage is that the DGs can share loads according to their increment costs. A robust distributed controller is designed for sharing active and reactive power in [93]. It use partial feedback linearization and ensure the robustness by considering structured uncertainties. The concept of the graph theory is also adopted.

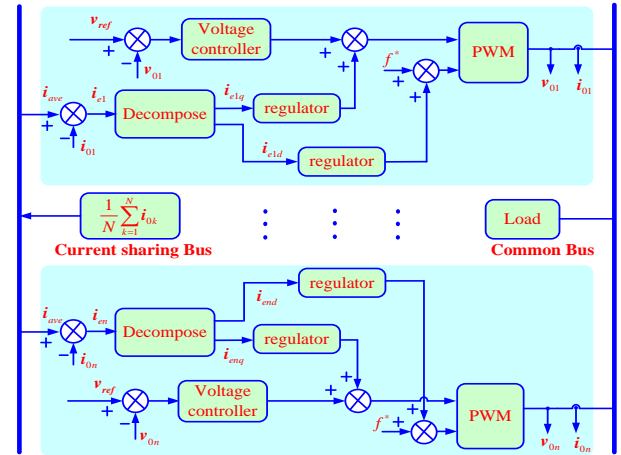

Fig. 3. Control structure of the distributed control.

In conclusion, the distributed control has no central control board and every module is symmetric. Voltage regulation and fundamental power sharing are well controlled. However, interconnections between the inverters are still necessary. This degrades the flexibility and redundancy of the system. As the number of parallel modules and distance of the interconnected lines increase, more interference is expected in the system.

## III. DROOP CHARACTERISTIC BASED TECHNIQUES

The control strategies that operate without inter-unit communications for power sharing control are based on droop concept [2]-[3], [11], [16]-[21], [94]-[96]. Operation without communication links is often essential to connect remote inverters. It can avoid complexity and high costs, and improve redundancy and reliability requirements of a supervisory system. Also, such a system is easier to expand because of the plug-and-play feature of the modules which allows replacing one unit without stopping the whole system. Therefore, communication lines are often avoided especially for long distances and high investment cost.

However, droop characteristic presents several drawbacks:

- *Frequency and voltage deviations*: In islanding mode, the voltage and frequency of the microgrid are load-dependent. Steeper droop ensures better load sharing, yet results in larger frequency and voltage deviations, and even may cause instabilities in the microgrid. This is the inherent trade-off between the frequency and voltage regulation and load sharing accuracy for the droop method [34].
- *Harmonic loads*: The original droop method focuses on fundamental power sharing but doesn't take harmonic sharing into account in the case of nonlinear loads. If it's not coped properly, it would lead to harmonic circulating currents and poor power quality. Moreover, the calculation and smoothing of active and reactive power take some

delays, thus it presents a slow dynamic response [35]-[36].

- *The different and unknown line impedances:* The line impedances between the paralleled converters also affect the power sharing performance. When the line impedances between the inverters and point of common coupling are different, it could result in a large circulating current and low precision of power sharing among inverters [37], [38].
- *Fluctuant and changeable output power of DGs:* Another drawback of the original droop method is the poor performance with renewable energy resources because the output active power of micro-sources is usually fluctuant and changeable [39].

To overcome these drawbacks and minimize the circulating current under all situations, researchers have developed several improved droop control methods. These methods fall into four main categories, namely

- 1) Conventional and variants of droop control
- 2) Virtual structure based methods
- 3) “Construct and compensate” based methods
- 4) Hybrid droop/signal-injection based methods.

Besides the above four main categories, the most recent control methods based on droop characteristic has emerged from [94]-[96]. In [94], drooping the virtual flux instead of the inverter output voltage can avoid the complicated inner multi-loop feedback control and frequency-voltage deviations to some extent. Reference [95] presents a multivariable control topology, which offers a systematic and straight forward design approach with the loop shaping technique. It also realizes real power sharing by simultaneous drooping of both frequency and voltage amplitude, which enhances load sharing accuracy in resistive microgrids. The consensus-based droop control with sparse communication network obviously alleviates the effects of non-ideal line impedances with better dynamical performances in [96].

This Section will discuss conventional and improved droop controllers, and show the control schemes in detail.

#### A. Conventional Droop Control

The droop control method for the parallel connected inverters can avoid the dependency on communications. It is sometimes named as “wireless” control with no interconnection between the inverters. However it can lead to a confusion with the wireless communications in the sense of radiofrequency based communications. The basic idea of this control level (also named primary control) is to mimic the behavior of a synchronous generator, which is to reduce the frequency as the active power increases. When the inverter output impedance is highly inductive, hence the active and reactive powers drawn to the bus can be expressed as

$$\begin{cases} P_i = \frac{VE_i}{X} \sin \phi \\ Q_i = \frac{VE_i \cos \phi - V^2}{X} \end{cases} \quad (1)$$

Where  $X$  is the output reactance of an inverter,  $\phi$  is the phase angle between the output voltage of the inverter and the voltage of the common bus,  $E_i$  and  $V$  are the amplitude of the

output voltage of the inverter and the grid voltage, respectively. It can be found that the active power is predominately dependent on the power angle, while the reactive power mostly depends on the output voltage amplitude. This principle can be integrated in voltage source inverters (VSIs) by using the well-known  $P/Q$  droop method [16], [40], which can be expressed as

$$\begin{cases} f_i = f_{rated} - m_p \cdot (P_i - P_{rated}) \\ E_i = E_{rated} - n_Q \cdot (Q_i - Q_{rated}) \end{cases} \quad (2)$$

where  $i$  is the index representing each converter,  $f_{rated}$  and  $E_{rated}$  are the nominal frequency and voltage of the micro-source, respectively,  $P_i$  and  $Q_i$  are the average active and reactive power,  $P_{rated}$  and  $Q_{rated}$  are the nominal active and reactive power, respectively; and  $m_p$  and  $n_Q$  are the active and reactive droop slopes, respectively.

The choice of  $m_p$  and  $n_Q$  impacts the network stability, so they must be carefully and appropriately designed [41], [42]. Usually, the droops are coordinated to make each DG system supply apparent power proportional to its capacity [16].

$$\begin{cases} m_p = \frac{f_i - f_{min}}{P_i - P_{i,max}} \\ n_Q = \frac{E_{i,max} - E_{i,min}}{Q_{i,min} - Q_{i,max}} \end{cases} \quad (3)$$

The control algorithm with conventional droop control is illustrated in Fig. 4. The power stage consists of VSI with a LC filter and a coupling line inductor. The controller consist of three control loops: (i) a power sharing controller is used to generate the magnitude and frequency of the fundamental output voltage of the inverter according to the droop characteristic; (ii) a voltage controller is used to synthesize the reference filter inductor current vector; (iii) and a current controller is adopted to generate the command voltage by a pulse width modulation (PWM) module.

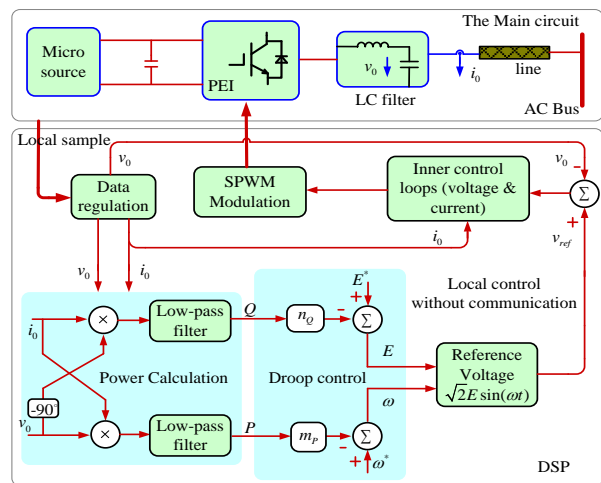

Fig. 4. Control structure of conventional P/f and Q/V droop control.

As discussed above, the conventional droop method can be implemented without communication between modules, and therefore is more reliable. However, it has some drawbacks as listed below:

- *Multiple control objectives:* Since there is only one control



variable for each droop characteristic, it isn't possible to satisfy multiple control objectives. For example, a design trade-off needs to be considered between the voltage  $f/V$  regulations and load  $P/Q$  sharing [34].

- *Mixed resistive and inductive line impedance:* The conventional droop method is developed assuming highly inductive equivalent impedance between the VSC and the AC bus. However, this assumption is challenged in microgrid applications since low-voltage distribution lines are mainly resistive. Therefore, equation (1) isn't valid for AC microgrids [34], [38]. Furthermore, if the line impedance is mixed resistive and inductive, then the active and reactive power will be strongly coupled. This case is important in medium-voltage (MV) microgrids, in which the power lines  $X/R$  ratio can be next to one.
- *No a global voltage variable:* As opposed to the frequency, the voltage isn't a global variable in a microgrid. Thus, the reactive power control is difficult to share between the parallel inverters and may result in circulating reactive current [37], [38]. Same problem may occur in highly resistive lines, especially for circulation of active current controlled through the voltage.
- *The nonlinear loads:* In case of nonlinear loads, the conventional droop method is only based on fundamental values and doesn't consider current or voltage harmonics. Since it only uses  $P$  and  $Q$  measurements which are usually average over one line cycle. The conventional droop method should be modified in order to share the harmonic currents [35], [36].

These potential drawbacks have been widely discussed in the recent literatures [34]-[38]. Proposed solutions will be discussed in following sections.

### B. VPD/FQB Droop Control

While the conventional frequency droop control method works well in a microgrid with mainly inductive line impedances, it may present problems when implemented it on a low-voltage microgrid, where the feeder impedance is mainly resistive. Note that the delivered active and reactive power of the inverter still increase with  $E$ , but here, the reactive power increases with the power angle  $\phi$ , and the active power remains increasing along with voltage variation ( $E - V_{com}$ ), as can be seen in the following well known small-angle approximation.

$$\begin{cases} P \approx \frac{V_{com} E - V_{com}^2}{Z} \\ Q \approx -\frac{V_{com} E}{Z} \cdot \phi \end{cases} \quad (4)$$

Thus, voltage active power droop and frequency reactive power boost (VPD/FQB) characteristics are alternatively considered [19], [46]-[48], as

$$\begin{cases} \omega_i = \omega_{rated} + m_Q \cdot Q_i \\ E_i = E_{rated} - n_P \cdot P_i \end{cases} \quad (5)$$

Droop/boost characteristics of VPD/FQB method are shown in Fig. 5. This kind of control offers an improved

performance for controlling low voltage AC microgrid with highly resistive transmission lines [46]. However, the VPD/FQB method strongly depends on system parameters which significantly restrict its application. Furthermore, it is also unable to properly share the load active current.

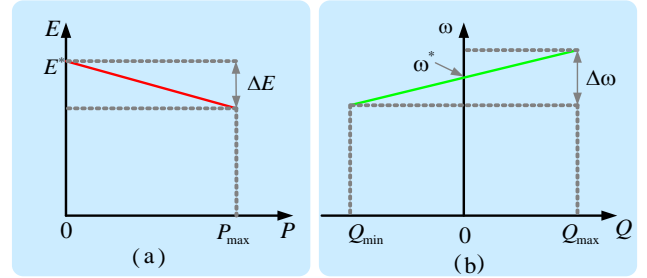

Fig. 5. Droop/boost characteristics for low-voltage AC microgrid.

### C. Complex Line Impedance Based Droop Method

Many problems cannot be solved by using the conventional droop control method, such as line impedance dependency, inaccurate  $P$  or  $Q$  regulation and slow transient response [34]-[38]. In [53], considering the impact of complex impedance, it proposes the controller that can simplify the coupled active and reactive power relationships, offer good dynamic performance, and be more convenient when the line impedance resistance and inductance parts are similar ( $X \approx R$ ) in MV microgrids. In this particular case, the droop functions can be expressed as

$$\begin{cases} \omega = \omega_0 - m_P \cdot (P - Q) \\ E = E_0 - n_Q \cdot (P + Q) \end{cases} \quad (6)$$

In [52], to facilitate simultaneous active and reactive powers control and regulate the PCC voltage, a  $P$ - $Q$ - $V$  droop control method is proposed. For electric systems with complex impedance, both active and reactive powers affect the voltage magnitude. Therefore, the droop characteristics for the proposed  $P$ - $Q$ - $V$  droop method is given by

$$V = V_{ref} + (n_d \cdot P) + (m_d \cdot Q) \quad (7)$$

where  $V_{ref}$  is the desired reference value of the PCC voltage, in this case, 1 p.u.;  $n_d$  and  $m_d$  are the active and reactive power coefficients for the proposed  $P$ - $Q$ - $V$  droop method. Moreover, these droop coefficients are adjusted online through a lookup table based on the PCC voltage level. The control algorithm of the proposed  $P$ - $Q$ - $V$  droop method is shown in Fig. 6.

Furthermore, additional loops such as impedance voltage drops estimator [38], grid parameters estimator [54], and reactive current loop [55] have been added to the conventional droop control in order to deal with line impedance mismatches and ensure good power sharing performance.

In order to improve the dynamic performances of parallel inverters in distributed generation systems, a "wireless"(droop) controller is proposed in [56].

$$\begin{cases} \phi = -m \cdot \int_{-\infty}^t P d\tau - m_P \cdot P - m_d \frac{dP}{dt} \\ E = E^* - n \cdot Q - n_d \cdot \frac{dQ}{dt} \end{cases} \quad (8)$$

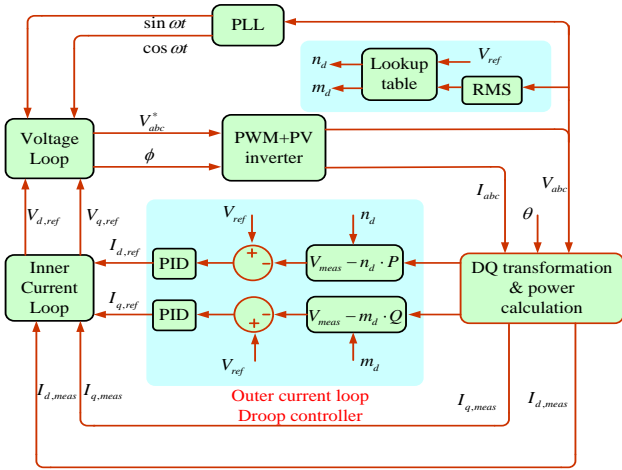

Fig. 6. The control algorithm with the proposed P-Q-V droop method.

In a relatively small AC microgrid, large load changes can be expected. Then an adaptive derivative term is used to add damping and to avoid large start-up transients and circulating currents [57], [58], as

$$\begin{cases} \omega = \omega^* + K_p \cdot (P_i - P_{i,ref}) + K_{pd} \frac{dP_i}{dt} \\ V_i = V_{ref} + K_Q \cdot (Q_i - Q_{i,ref}) + K_{qd} \frac{dQ_i}{dt} \end{cases} \quad (9)$$

where the choice of  $K_{pd}$  and  $K_{qd}$  can be obtained through the pole placement method.

Additionally, there are some other solutions to address dynamic response problems: droop based on coupling filter parameters [59], droop based on  $H_\infty$  derived from linear matrix inequality (LMI) control theory [60].

#### D. Angle Droop Control

In further investigation of the droop concept, some researchers have proposed power-angle droop control, in which the phase angle of the distributed source voltage, relative to a system-wide common timing reference is set [43]-[45]. As a result, the power requirement can be distributed among DGs, similarly as conventional droop does, by dropping the voltage angle and magnitude.

$$\begin{cases} \delta_i = \delta_{rated} - m_p \cdot (P_i - P_{i,rated}) \\ E_i = E_{rated} - n_Q \cdot (Q_i - Q_{i,rated}) \end{cases} \quad (10)$$

Where  $E_{rated}$  and  $\delta_{rated}$  are the rated voltage magnitude and angle of the DG respectively, when supplying their rated power levels of  $P_{i,rated}$  and  $Q_{i,rated}$ . Coefficients  $m_p$  and  $n_Q$  indicate active and reactive power droop gains. These values are chosen to meet voltage regulation requirement in the microgrid. The coefficient values for different DGs are chosen in order to share the load in proportion to their ratings.

The angle droop is able to provide proper load sharing among the DGs without a significant steady-state frequency drop in the system. And it has advantageous as the frequency maximum restricts the choice of droop gain in the conventional frequency droop control. Moreover, no communication is needed between DGs. However, if the local control boards aren't synchronized each other, the

imperfection of the crystal clock of the digital processors makes frequencies of each inverter slightly different, which will lead to running out of phase limits after certain time, leading to system instability. Some authors suggest the CAN bus or even global positioning system (GPS) to synchronize DGs. However, the loss of the global synchronizing signal at some DG units should be further investigated.

#### E. Voltage Based Droop Control

This control method is another type of P/V control. The control strategy presents a constant power band control of islanding AC microgrid, which operates without inter-unit communication in a fully distributed manner and takes the specific characteristics of the microgrid into account. These characteristics include the lack of rotating inertia, resistive line, and high share of DGs, which are less controllable than central generators and require optimal power exploitation [49]-[51].

The voltage-based droop (VBD) control strategy [49] consists of a P/V droop controller which is divided into two droop controllers ( $V_g/V_{dc}$  and  $P/V_g$  droops) and constant-power bands, as illustrated in Fig. 7.

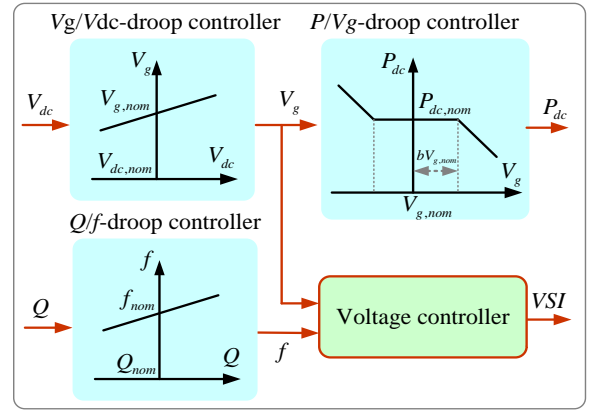

Fig. 7. Droop control with constant power band.

First, the  $V_g/V_{dc}$  droop control principle is based on the specific characteristics of islanding AC microgrid. If an unbalance occurs between the generated power and the absorbed power, the dc link voltage  $V_{dc}$  of the power source changes. Therefore,  $V_{dc}$  is the indicator for ac power change.

$$V_g^* = V_{g,nom} + m \cdot (V_{dc} - V_{dc,nom}) \quad (11)$$

where  $V_{g,nom}$  and  $V_{dc,nom}$  are the nominal voltage of AC and DC side of power converter. Note that a slightly change of  $V_g$  leads to a change of the power delivered to the electrical network. To limit the significant deviation of AC side voltage,  $P_{dc}/V_g$  droop with constant power band is used [49], as

$$P_{dc} = \begin{cases} P_{dc,nom} - K_p \cdot (V_g - (1+b) \cdot V_{g,nom}), & \text{if } V_g > (1+b)V_{g,nom} \\ P_{dc,nom}, & \text{if } (1-b)V_{g,nom} < V_g < (1+b)V_{g,nom} \\ P_{dc,nom} - K_p \cdot (V_g - (1-b) \cdot V_{g,nom}), & \text{if } V_g < (1-b)V_{g,nom} \end{cases} \quad (12)$$

where  $P_{dc,nom}$  is the rated active power of the AC-side of power

converter, and  $K_p$  is the power droop gain. Note that the width  $b$  of this band is dependent on the nature of the source.

$V_g/V_{dc}$  droop control can be used along with  $P_{dc}/V_g$  control in AC microgrids in order to take the advantages of both control methods. With the  $V_g/V_{dc}$  droop control, the microgrid voltage can be changed by detecting changes of  $V_{dc}$ , and balance is achieved without the need to change  $P_{dc}$ . In the meantime, frequent power changes can be avoided. No communication for the primary control is required, and the tolerated voltage deviation from its nominal value is effectively used for the control. The overall scheme of the droop control with constant power band is shown in Fig. 8.

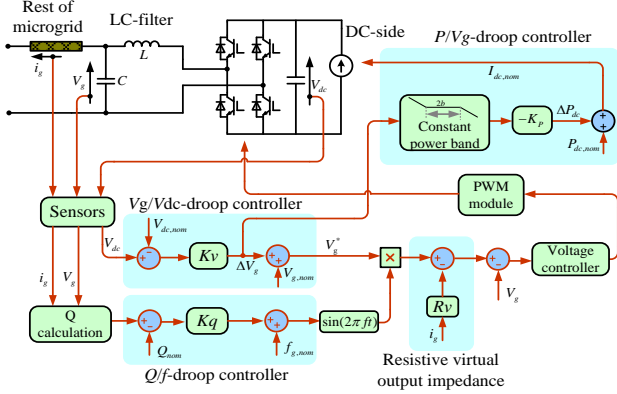

Fig. 8. The overall scheme of droop control with constant power band.

In summary, voltage based control strategy makes full utilization of the allowable range of the output voltage. In this range, the renewable energy sources are actively dispatched as they operate at maximum power tracking point (MPPT). This is particularly advantageous for DGs since their energy can be used more efficiently. Additionally, by combining the  $P/V_g$  droop control,  $P_{dc}$  can be changed in case the constant power band is surpassed, which increases the power flexibility in AC microgrid and avoids the voltage-limit violation. However, this control requires the micro-source to have certain ability to dispatch energy easily. Therefore, DGs require the multi-stage controller to dispatch the energy, which may affect the system efficiency to some extent.

#### IV. VIRTUAL-STRUCTURE-BASED METHODS

##### A. Virtual Output Impedance Loop

In order to avoid the active and reactive power coupling, a typical and popular approach is based on virtual output impedance method [6], [19], [53], [61]-[62]. This control method is implemented by including fast control loops in the droop control method, as shown in Fig. 9. As a result, the expected voltage can be modified [19], as

$$V_{ref} = V^* - Z_D(s) \cdot i_0 \quad (13)$$

where  $Z_D(s)$  is the virtual output impedance, and  $V^*$  is the output voltage reference under no load condition. In general, the output inductance can be produced by emulating an inductive behavior. This can be achieved by drooping the output voltage proportionally to the derivative of the output current with respect to the time, so that  $Z_D(s)$  is purely inductive, i.e.  $Z_D(s) = sL_D$ . However, differentiation can amplify high frequency noise, which may destabilize the DG

voltage control scheme, especially during transients. This issue can be overcome by using a low-pass filter instead of a pure derivative term of the output current [19].

$$V_{ref} = V^* - L_D \frac{s}{s + \omega_c} i_0 \quad (14)$$

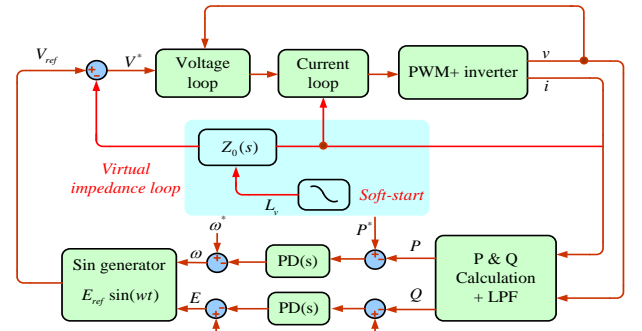

Fig. 9. The control scheme of droop control with virtual impedance.

If the virtual impedance  $Z_D(s)$  is properly adjusted, it can prevent occurrence of current spikes when the DG is initially connected to the AC microgrid. The soft starting can be facilitated by considering the time-variant virtual output impedance, as

$$Z_D(t) = Z_f - (Z_f - Z_i)e^{-t/T} \quad (15)$$

where  $Z_i$  and  $Z_f$  are the initial and final values of the virtual output impedance, respectively, and  $T$  is the time constant of the soft starting process. Also, if the output inductance can be produced by emulating a resistive behavior, the system stability can be improved [64]. Recently, the virtual output impedance method has been modified for harmonic current sharing [63], which is introduced in following subsection.

##### B. Enhanced Virtual Impedance Loop

The islanding AC microgrid may have serious power quality problems due to the increasing presence of nonlinear loads. To realize a better reactive and harmonic power sharing, the research [63] proposes an enhanced control method using virtual impedance at the fundamental and selected harmonic frequencies. Similar in virtual fundamental output impedance, this enhanced control method introduces the harmonic virtual impedance. The overall scheme of droop control with enhanced virtual impedance is shown in Fig. 10.

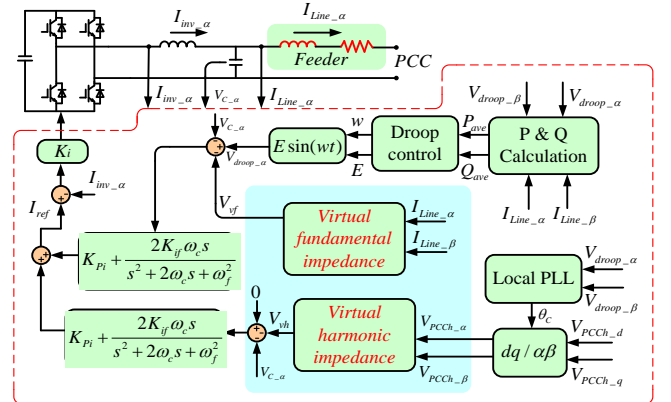

Fig. 10. The scheme of enhanced virtual impedance method.

This enhanced virtual impedance control method can realize



better reactive and harmonic power sharing, alleviate the computational load at DG unit local controller without using any fundamental and harmonic components extractions, and mitigate the PCC harmonic voltages by reducing the magnitude of DG unit equivalent harmonic impedance. However, it requires the knowledge of the physical line impedance parameters, and low-bandwidth communications.

Additionally, virtual impedance design rules are presented in [64], and a robust virtual impedance implementation is proposed, which can alleviate voltage distortion problems caused by harmonic loads.

### C. Virtual Frame Transformation Method

Another method based on a virtual structure is the virtual frame transformation [6], [65]. In general, both line reactance  $X$  and resistance  $R$  need to be considered. The active and reactive powers drawn to the bus can be expressed as

$$\begin{cases} P_i \cong \frac{V}{Z}[(E_i - V) \cos \theta + E_i \phi \sin \theta] \\ Q_i \cong \frac{V}{Z}[(E_i - V) \sin \theta - E_i \phi \cos \theta] \end{cases} \quad (16)$$

Where  $\phi$  is the phase angle between the output voltage of the inverter and the common bus,  $E$  and  $V$  are the amplitude of the output voltage of the inverter and the grid voltage,  $Z$  and  $\theta$  are the magnitude and phase of the impedance respectively.

The use of an orthogonal linear rotational transformation matrix  $T$  from active and reactive power  $P$  and  $Q$  to the modified active and reactive power  $P'$  and  $Q'$  is proposed as

$$\begin{bmatrix} P' \\ Q' \end{bmatrix} = T_{PQ} \cdot \begin{bmatrix} P \\ Q \end{bmatrix} = \begin{bmatrix} \sin \theta & -\cos \theta \\ \cos \theta & \sin \theta \end{bmatrix} \cdot \begin{bmatrix} P \\ Q \end{bmatrix} \quad (17)$$

Despite the line impedance is mixed,  $P/Q$  decoupling is achieved as if the network were purely inductive. In general, the accurate value  $R/X$  isn't known, but an estimation of  $R/X$  may be sufficient to perform the method [54].

Similarly to [6] and [54], a virtual frequency/voltage frame transformation ( $\omega' - E'$ ) is proposed in [66]-[68].

$$\begin{bmatrix} \omega' \\ E' \end{bmatrix} = T_{\omega E} \cdot \begin{bmatrix} \omega \\ E \end{bmatrix} = \begin{bmatrix} \sin \varphi & \cos \varphi \\ -\cos \varphi & \sin \varphi \end{bmatrix} \cdot \begin{bmatrix} \omega \\ E \end{bmatrix} \quad (18)$$

where  $E$  and  $\omega$  are calculated through the conventional droop equations in (2). The transformed voltage and frequency,  $E'$  -  $\omega'$ , are then used as reference values for the DG voltage control loop. The VPD/FQB method and the conventional droop control are special cases where  $\varphi = 0$  and  $\varphi = 90^\circ$ . The  $\omega' - E'$  virtual frame transformation is shown in Fig. 11.

The proposed real and reactive power control is based on the virtual frequency and voltage  $\omega' - E'$  frame, which can effectively decouple real and reactive power flows and improve the system transient and stability performance. However, one issue with the virtual frame power control is that if the frame transformation angle isn't the same for all DG units, the microgrid frequency and voltage will be converted to different values in different virtual frames. Consequently, if two DGs are injecting different powers or line impedances aren't matched, the transformation angle will be different and

both reference frames will be out of synchronism.

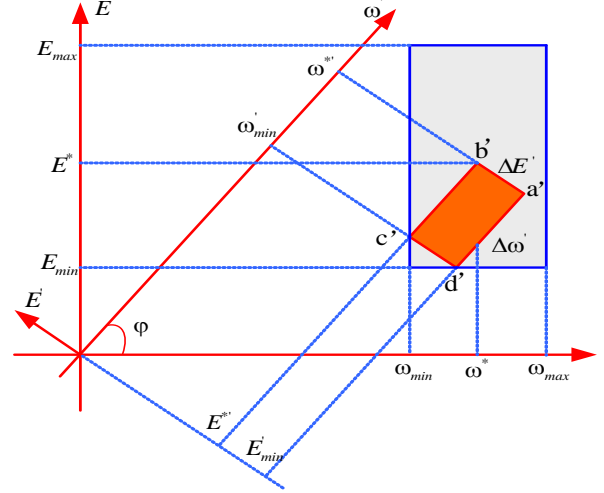

Fig. 11. The details of the  $\omega' - E'$  virtual frame transformation.

## V. CONSTRUCTION-AND-COMPENSATION-BASED METHODS

### A. Adaptive Voltage Droop Control

Recently, some researchers have proposed control methods based on construction and compensation ideas. In [69], it proposes a novel adaptive voltage droop scheme for the parallel operation of DGs in an islanding AC microgrid. In this method, two terms are constructed to the conventional reactive power ( $Q-V$ ) control. One term is used to compensate for the voltage drop across the transmission lines. The other term is added to hold the system stability and improve reactive power sharing under heavy loading conditions. In order to illustrate this control technique, a two-DG system with generic output impedances is shown in Fig. 12. The voltage of a single DG can be derived as

$$V_i = E_i^* - D_{Q_i} Q_i - \frac{r_i P_i}{E_i^*} - \frac{x_i Q_i}{E_i^*} \quad (19)$$

The two latter terms represent the voltage drop on the internal line impedance. These terms can be added to the conventional reactive power control, which compensates for voltage drops on the power lines as

$$E_i = E_i^* - D_{Q_i} Q_i + \left( \frac{r_i P_i}{E_i^*} + \frac{x_i Q_i}{E_i^*} \right) \quad (20)$$

Additionally, to improve the system stability and suit for any load conditions, the method presented in [69] adopts the voltage droop coefficient as a nonlinear function of active and reactive power.

$$\begin{cases} E_i = E_i^* - D_i(P_i, Q_i) \cdot Q_i + \left( \frac{r_i P_i}{E_i^*} + \frac{x_i Q_i}{E_i^*} \right) \\ D_i(P_i, Q_i) = D_{Q_i} + m_{Q_i} Q_i^2 + m_{P_i} P_i^2 \end{cases} \quad (21)$$

where  $D_{Q_i}$ ,  $m_{Q_i}$  and  $m_{P_i}$  are droop coefficients. The three terms can mitigate the negative impacts of the active power control and the microgrid parameters on the reactive power control, improving the system stability and the reactive power sharing under heavy loading conditions. Nevertheless this method requires good knowledge of the power line parameters [69].

Small errors may result in a positive feedback, and thus may cause system instability.

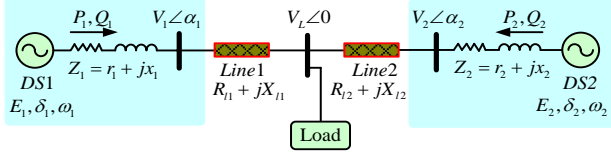

Fig. 12. A typical two-DGs system.

### B. Synchronized Reactive Power Compensation Method

To improve the reactive power sharing accuracy, an enhanced control strategy is proposed in [70]-[71], which estimates the reactive power control error by injecting a small real power disturbance that is activated by low-bandwidth synchronization signals from the central controller. Also, a slow integration term is added to the conventional reactive power droop control in order to eliminate reactive power sharing errors. With the proposed scheme, reactive power sharing errors are significantly reduced. After the compensation, the proposed droop controller will be automatically switched back to the conventional droop controller. The improved droop control can be described as

$$\begin{cases} \omega = \omega_0 - (D_p \cdot P + D_Q \cdot Q) \\ E = E_0 - D_Q \cdot Q + \left(\frac{K_C}{s}\right) \cdot (P - P_{AVE}) \end{cases} \quad (22)$$

where  $K_C$  is the integral gain, which is selected to be the same for all the DG units. Fig. 13 illustrates the diagram of the proposed synchronized reactive power compensation method. This control strategy is realized by two stages [71]. The conventional droop method is used in the first stage, and the averaged real power in the steady-state should be measured for use in the second stage. In the last stage, the reactive power sharing error is compensated by introducing a real-reactive power coupling and using an integral voltage magnitude term.

In summary, the synchronized reactive power compensated method injects a real-reactive power transient coupling term to identify the errors of reactive power sharing, and improves the reactive power sharing accuracy [71]. However, the method needs synchronization signals from a central controller. It can be seen as a classical event-triggered system whose stability isn't easy to be guaranteed.

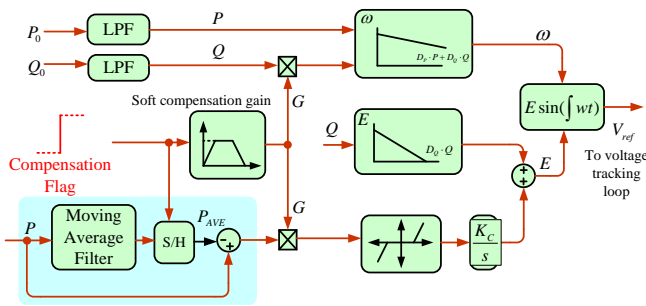

Fig. 13. Droop control with synchronized reactive power compensation.

### C. Droop Control Based Synchronized Operation

The method mainly includes two important operations: error reduction operation and voltage recovery operation [100]. The sharing accuracy is improved by the sharing error

reduction operation, which is activated by the low-bandwidth synchronization signals. However, the error reduction operation will result in a decrease in output voltage amplitude. Therefore, the voltage recovery operation is proposed to compensate the decrease. The needed communication in this method is very simple, and the plug-and-play is reserved. The improved droop control can be described as

$$E_i(t) = E^* - n_i Q_i(t) - \sum_{n=1}^{k-1} K_i Q_i^n + \sum_{n=1}^k G^n \Delta E \quad (23)$$

where  $k$  denotes the times of synchronization event until time  $t$ . According to (23), the control is a hybrid system with continuous and discrete traits. Therefore, the droop equation at the  $k$ -th synchronization interval could be expressed as

$$E_i^k = E^* - n_i Q_i^k - \sum_{n=1}^{k-1} K_i Q_i^n + \sum_{n=1}^k G^n \Delta E \quad (24)$$

where  $G^n$  is the voltage recovery operation signal at the  $n$ -th synchronization interval,  $G^n$  has two possible values: 1 or 0. If  $G^n=1$ , it means the voltage recovery operation is performed.  $Q_i^n$  represents the output reactive power of DG- $i$  unit at the  $n$ -th synchronization interval.  $K_i$  is a compensation coefficient for the DG- $i$  unit,  $\Delta E$  is a constant value for voltage recovery [100]. Besides, the control timing diagram is shown in Fig. 14. The sharing error operation and the voltage recovery operation are performed in update interval. Sampling operation occurs in sampling interval. There is a time interval  $\tau$ , which is long enough to guarantee the system in steady state. The method is robust to the time delay because all the necessary operations only need to be completed in an interval, not a critical point.

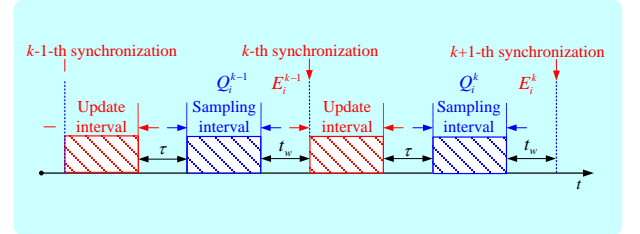

Fig. 14. Control timing diagram of one DG with the two consecutive synchronization events.

### D. Q-V Dot Droop Control Method

This method constructs the relationships of reactive power  $Q$  and the change rate of the DG output voltage ( $\dot{V}$ ) in order to improve the reactive power sharing [72]-[74]. The proposed  $Q-\dot{V}$  droop control can avoid this coupling dependence. The change rate of voltage will drive continuously until the desired  $Q$  flows, and its performance can be less dependent on the line impedances. The  $Q-\dot{V}$  droop controller is expressed as

$$\begin{cases} \dot{V}_x = \dot{V}_{0x} - n_x \cdot (Q_{0x} - Q_x) \\ V_x^* = V_{0x} + \int_t \dot{V}_x d\tau \end{cases} \quad (25)$$

where  $n_x$  is the droop coefficient,  $\dot{V}_{0x}$  is the nominal  $\dot{V}_x$  which is set to zero, and  $Q_{0x}$  is the reactive power set point at the nominal  $\dot{V}_x$ , which is related to the reactive power capacity of DG. Also,  $V_{0x}$  is the nominal phase voltage magnitude and  $V_x^*$

is the voltage command. In the steady state, the  $\dot{V}_x$  must be reset back to zero to prevent varying output voltage magnitudes. So,  $\dot{V}_x$  restoration mechanism is designed [73] as

$$\frac{d}{dt}Q_{0x} = K_{res} \cdot Q_{Rx} \cdot (\dot{V}_{0x} - \dot{V}_x) \quad (26)$$

The control diagram of proposed Q-V droop control and the DG control block diagram are shown in Fig. 15.

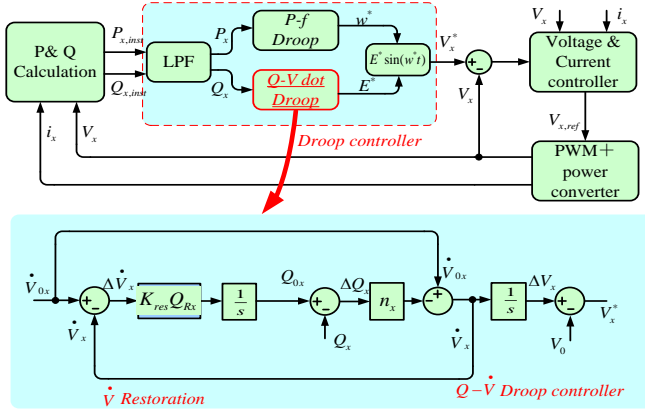

Fig. 15. Q-V droop controller and the control block diagram of single DG.

In the proposed control strategy, the control result is related to the initial condition of the voltage change rate. Despite the system is stability, the steady-state solutions may not exist. Moreover, the power sharing performances aren't necessarily superior to those of conventional methods. The use of the integral term in (25), tries to restore the voltage with a local control loop, whose response will depend on the initial conditions of such an integrator, thus leading to system instability. Therefore, this controller isn't feasible in real microgrid applications.

### E. Common Variable Based Control Method

The common variable is critical for the active and reactive power sharing. Because of the mismatch between the DG output interface inductors in microgrid, it is really difficult to achieve reactive power sharing. Similar with the active power control, some researchers have proposed the adjustable reactive power sharing method, where an integral controller is used to regulate the common bus voltage  $V_{com}$  [48], [75], [76].

$$E_i = K_q \int (V_{ref} - V_{com}) dt \quad (27)$$

where  $K_q$  is the integral gain and

$$V_{ref} = E^* - D_Q \cdot Q_i \quad (28)$$

In the steady state,  $V_{com}$  and  $V_{ref}$  of each DG are equal. Moreover, the steady-state reactive power can be calculated as

$$Q = \frac{E^* - V_{com}}{D_Q} \quad (29)$$

From (29), it is known that the reactive power for each DG is equal. Then, microgrid operation parameters will no longer affect the reactive power control. Similarly, the strategy proposed in [76] is suited for inverters with resistive output impedance. The improved active power control is modified

$$E_i = \int [K_e \cdot (E^* - V_{com}) - K_q \cdot P_i] dt \quad (30)$$

In summary, the control method based on a common variable can achieve accurate proportional load sharing among parallel DGs, and is robust to the system parameter variations. However, these methods have a potential issue of requiring the load voltage information which is difficult to measure when it exists long distances between the DG and the common bus. Moreover, the common voltage may not exist when the configuration of AC microgrid is complex or in a real distributed system with dispersed loads.

## VI. HYBRID DROOP/SIGNAL-INJECTION BASED METHOD

Conventional droop control cannot ensure a constant voltage and frequency, neither an exact power sharing. But an advantage of the control can avoid communication among the DGs. Communication based control is a simple and stable strategy providing a good current sharing, yet a low reliability and redundancy. Therefore, to take advantage of their respective advantages, a hybrid scheme combining two control methods is presented in [47], [97]-[99].

The sharing of real and reactive powers between the DGs is easily implemented by two independent control variables: power angle and voltage amplitude. However, adding external communication is still not desired. Such communications increase the complexity and reduce the reliability, since power balance and system stability rely on these signals.

Several current sharing techniques based on frequency encoding of the current sharing information have been presented in [36] and [77]. The power lines are used for the communication for the power sharing. Most importantly, this technique doesn't require extra control interconnections and automatically compensates for inverter parameter variations and line impedance imbalances. In [36], each DG injects a small AC voltage signal to the microgrid. Frequency signal  $w_q$  is determined by the reactive power  $Q$  of the DG.

$$\omega_q = \omega_{q0} + D_Q \cdot Q \quad (31)$$

where  $w_{q0}$  is the nominal frequency of injected AC signals and  $D_Q$  is the boost coefficient. The small real power transmitted through the signal injection is then calculated. And the value of the output voltage,  $E$ , is adjusted [36], as

$$E = E^* - D_p \cdot P_q \quad (32)$$

In this way, a Q/V droop is achieved, through the frequency component  $w_q$ . In the presence of nonlinear loads, the harmonic distortion  $D$  caused by non-linear loads is shared in similar way. A control signal with a frequency that is drooped with  $D$  is injected. The power in this injected control signal is used to adjust the bandwidth of the voltage loop [36].

$$\begin{cases} \omega_d = \omega_{d0} - mD \\ D = \sqrt{S^2 - P^2 - Q^2} \\ BW = BW_0 - D_{bw} P_d \end{cases} \quad (33)$$

where  $BW_0$  is the nominal bandwidth of the voltage loop and  $D_{bw}$  is the droop coefficient. The block diagram of the signal injection method is shown in Fig.16.

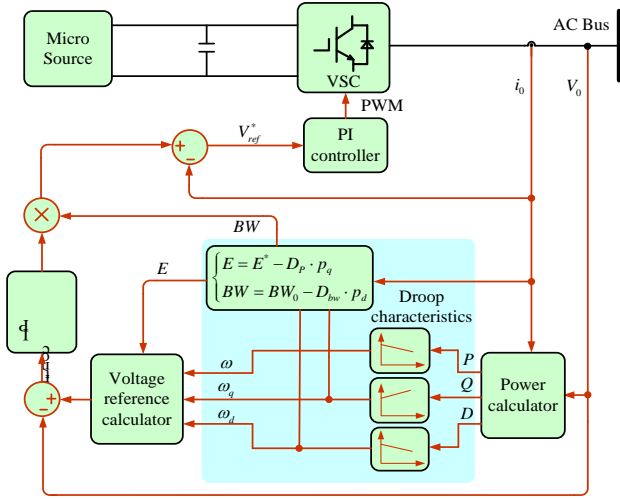

Fig. 16. The block diagram of the frequency signal injection method.

Signal injection method properly controls the reactive power sharing and isn't sensitive to variations in the line impedances [36], [77]. It is also suited for linear and nonlinear loads. However, it doesn't guarantee the voltage regulation. Other issues of this method are the complexity and the need for measuring and generating high-frequency components. Also, signal injection method can deteriorate the power quality, which increases the losses on the transmission lines because of the harmonic current generated by the method. Moreover, this injected signal can result in the inter harmonic and resonance. Since this method adjusts the voltage droop bandwidth, it may attenuate the system stability. As an alternative, harmonic virtual impedance is proposed in [63].

## VII. DISCUSSION OF VARIOUS METHODS AND FUTURE TRENDS

From the previous discussion, it can be seen that each of these proposed control techniques has its own characteristics, advantages and disadvantages. The communication based methods can provide tight current sharing, high power quality, fast transient response, and reduce circulating currents between the inverters. However, it requires communication links and high bandwidth control loops. Further, it isn't easy to be expanded due to the need for load current measurement and to know the number of inverters in the system. The required interconnections make the system less reliable and not truly redundant and distributed.

Droop control methods are based on local measurements of the network state variables which make DG truly distributed and absolute redundancy, as they don't depend on cables for reliable operation. It has many desirable features such as expandability, modularity, flexibility and redundancy [61], [62], [78]. However, the droop control concept has some limitation including frequency and amplitude deviations, slow transient response and the possibility of circulating current among inverters due to line impedance mismatches between inverters and the common bus.

Recently, researchers have improved the two control strategies, or combined these two control method to overcome the corresponding drawbacks. The potential advantages and disadvantages of the communication based methods and the

droop methods are summarized in Tables I and II. From these two Tables, it is difficult for only one control scheme to overcome all drawbacks for all applications. However, further investigation of these control techniques will help improve the design and implementation of future distributed AC microgrid architectures.

The future trends in control strategies for microgrid are essentially related to energy services and protection, which include the demand response, optimal power flow, market participation, storage management, and so on. These technologies could be interesting when connecting microgrids to the main grid or when deploying a cluster of multiple microgrids. Thus, multi-agent systems and hierarchical control [62] could negotiate the interchange of energy between microgrids or microgrid clusters. Therefore, the multi-agent control and hierarchical control are becoming a clear trend of research in microgrids technologies, while communication systems are becoming more important to make these applications feasible. In addition, the research about the impacts of stability and reliability with a large number of microgrids connection are still behind. So, it's also difficult to convert the current conventional distribution network structure in short time. The details of future trends include the following:

- **Network-based Hybrid Distributed Control:** Smart distributed grid has been proved that it can improve the efficiency and reliability of the power system. Network-based hybrid distributed control of microgrids is essential to optimize the performance of microgrids under high penetration level of DG resources, which is treated by algebraic graph theory. A converge analyses are carried out in [101], and it proposes a control scheme which can not only realize frequency recovery, accurate power sharing, high reliability and robustness, but also optimize the energy flow in the system.
- **Fault-tolerant control:** The fault-tolerant control is a key technology area which should not only manage supply and demand of electricity more effectively, but also apply appropriate corrective actions to eliminate, mitigate and prevent various emergency situations such as faults, outages, disturbances to power quality or changes in the user needs [102]. Moreover, the fault tolerant control also can be implemented for self-healing and anti-islanding which enhances the capability of fault-ride through and ensures the reliability and security of the systems.
- **Cost-Prioritized Droop Schemes:** All the optimization schemes are to reduce the cost, so it seems to more feasibly and effectively propose a droop scheme based on cost-prioritized. Reference [103] proposes several droop schemes in consideration of operating costs. These are nonlinear variable droop schemes which regard the related cost function as the droop coefficients.
- **Variable Inertia:** The traditional bulk power system consists of many synchronous generators with a relatively large inertia. But microgrids don't have the kinetic energy and spinning reserve, which consist of many inverter-based distributed resources with a low inertia. Then, the low inertia may lead to severe voltage or frequency deviations



in some big disturbances and sudden changes. So the system should show a large inertia when the frequency will deviate, and a low inertia when to recover the frequency. The objective of the variable inertia is always to keep the normal frequency.

- **Stability issues:** The stability of microgrid has been studied for long years. However, the stability of the microgrid has never been studied perfectly when it supplies some complex loads such as the dynamic loads, the constant loads, inductor motor, the pulsed loads and the electric vehicles. So, it's necessary to propose the special models and control methods to solve the voltage, frequency and power-angle stabilities for these composite loads.

### VIII. CONCLUSION

This paper has presented an overview of the different power sharing control strategies of DGs in islanding AC microgrids. Detailed description of the control schemes has been given. The communication based methods of

concentrated control, master/slave control, and distributed control perform a good current sharing, yet a low reliability and redundancy. However, the droop characteristic based control method has been presented to avoid communication lines/cables, thus, which can help increase the system reliability, modularity and flexibility. Also, improvement of virtual structure based method, constructed and compensated based method, common variable based method, and signal injection method, have been proposed to overcome the inherent drawbacks of the traditional droop methods for decoupling the active and reactive control laws, robustness with respect to the system parameters, addressing nonlinear loads, and proper voltage regulation. Moreover, various control approaches are compared in terms of their respective advantages and disadvantages. Finally, the future trends for primary control techniques of AC microgrids are briefly discussed. The studies show that in the process of development of microgrid, challenges and opportunities coexist.

TABLE I.  
Potential Advantages And Disadvantages Of The Communication Based Control Methods

Communication based control	Potential advantages	Potential disadvantages
Concentrated control [23]-[27]	<ul style="list-style-type: none"> <li>✓ Good power sharing in steady state and transients</li> <li>✓ Constant voltage and frequency regulation</li> </ul>	<ul style="list-style-type: none"> <li>✗ High bandwidth communication required</li> <li>✗ Low reliability and expandability</li> </ul>
Master/slave control [28]-[31]	<ul style="list-style-type: none"> <li>✓ Recover the output voltage easily</li> <li>✓ Good power sharing in steady state</li> </ul>	<ul style="list-style-type: none"> <li>✗ High current overshoot during transients</li> <li>✗ Require high bandwidth communication</li> <li>✗ Low redundancy</li> </ul>
Distributed control [24], [32],[33]	<ul style="list-style-type: none"> <li>✓ Symmetrical for every module</li> <li>✓ Constant voltage and fundamental power sharing.</li> </ul>	<ul style="list-style-type: none"> <li>✗ Require communication bus</li> <li>✗ Degrade the modularity of the system</li> </ul>



TABLE II.  
Potential Advantages And Drawbacks Of Droop Characteristic Based Control Methods

Droop characteristic based control		Potential advantages	Potential drawbacks
Conventional and variants on droop control	Conventional frequent droop control [16],[40]	<ul style="list-style-type: none"> <li>✓ Easy implementation without communication</li> <li>✓ High expandability, modularity and flexibility</li> </ul>	<ul style="list-style-type: none"> <li>✗ Affected by the physical parameters</li> <li>✗ Poor voltage-frequency regulation</li> <li>✗ Slow dynamic response</li> <li>✗ Poor harmonic sharing</li> </ul>
	VPD/FQB droop control [19],[46]-[48]	<ul style="list-style-type: none"> <li>✓ For highly resistive transmission lines</li> <li>✓ Easy implementation without communication</li> </ul>	<ul style="list-style-type: none"> <li>✗ Affected by the physical parameters</li> <li>✗ Poor voltage and frequency regulation</li> </ul>
	Complex line impedance [52]-[58]	<ul style="list-style-type: none"> <li>✓ Decoupled active and reactive controls</li> <li>✓ Improved voltage regulation</li> </ul>	<ul style="list-style-type: none"> <li>✗ Line impedances should be known in advance</li> </ul>
	Angle droop control [43]-[45]	<ul style="list-style-type: none"> <li>✓ Constant frequency regulation</li> </ul>	<ul style="list-style-type: none"> <li>✗ Require GPS signals</li> <li>✗ Poor performance of power sharing</li> </ul>
	Droop control with constant power band [49]-[51]	<ul style="list-style-type: none"> <li>✓ Considering the specific characteristic of micro-source</li> <li>✓ Operating in MPPT within a certain range and energy used more efficiently</li> <li>✓ Avoiding voltage-limit violation</li> </ul>	<ul style="list-style-type: none"> <li>✗ Micro-source requires dispatched abilities</li> <li>✗ Require multi-stages controllers and affect system efficiency</li> </ul>
Virtual structure based method	Virtual output impedance control [19],[53],[61]-[62]	<ul style="list-style-type: none"> <li>✓ Not affected by the physical parameters</li> <li>✓ Improved performance of power sharing and system stability</li> </ul>	<ul style="list-style-type: none"> <li>✗ Voltage regulation isn't guaranteed</li> <li>✗ Requires relatively high bandwidth for controller</li> </ul>
	Enhanced virtual impedance control [63]	<ul style="list-style-type: none"> <li>✓ Can handle linear and nonlinear loads power sharing</li> <li>✓ Mitigates the PCC harmonic voltage</li> </ul>	<ul style="list-style-type: none"> <li>✗ Requires the low-bandwidth communication</li> <li>✗ The physical parameters should be known in advance</li> </ul>
	Virtual frame transformation method [6],[65]-[68]	<ul style="list-style-type: none"> <li>✓ Decoupled active and reactive power controls</li> </ul>	<ul style="list-style-type: none"> <li>✗ Hard to exactly ensure the same transformation angle for all DGs</li> <li>✗ The physical parameters should be known in advance</li> </ul>
Constructed and Compensated based method	Adaptive voltage droop control [69]	<ul style="list-style-type: none"> <li>✓ Improved voltage regulation</li> <li>✓ Improved system stability and power sharing under heavy load condition</li> </ul>	<ul style="list-style-type: none"> <li>✗ The physical parameters should be known in advance</li> </ul>
	Synchronized reactive power compensation [70]-[71]	<ul style="list-style-type: none"> <li>✓ Improved power sharing performances</li> <li>✓ Not influenced by the physical parameters</li> </ul>	<ul style="list-style-type: none"> <li>✗ Requires the low bandwidth synchronized communication</li> </ul>
	Droop control based Synchronized operations [82]	<ul style="list-style-type: none"> <li>✓ Improved power sharing performances</li> <li>✓ Not affected by the physical parameters</li> <li>✓ Robust to communication delay</li> </ul>	<ul style="list-style-type: none"> <li>✗ Requires the simple low bandwidth synchronized communication</li> </ul>
	$Q-V$ dot control method [72]-[74]	<ul style="list-style-type: none"> <li>✓ Same as conventional droop</li> </ul>	<ul style="list-style-type: none"> <li>✗ Depend on the initial conditions</li> <li>✗ Steady-state solution may not exist</li> <li>✗ Easy to destabilize</li> </ul>
Common variable based control method [48],[75],[76]		<ul style="list-style-type: none"> <li>✓ Accurate reactive power sharing</li> <li>✓ Not affected by the physical parameters</li> </ul>	<ul style="list-style-type: none"> <li>✗ Hard to measure the common voltage due to long distance</li> </ul>
Signal injection method [36],[77]		<ul style="list-style-type: none"> <li>✓ Can handle linear and nonlinear loads</li> <li>✓ Not affected by the system parameters</li> </ul>	<ul style="list-style-type: none"> <li>✗ Cause harmonic distortion of voltage</li> </ul>

## IX. REFERENCES

- [1] K. Moslehi and R. Kumar, "A reliability perspective of the smart grid," *IEEE Trans. Smart Grid*, vol.1, no.1, pp.57-64, Jun.2010.
- [2] R. H. Lasseter, "Microgrids," in *Proc. IEEE Power Engineering Society Winter Meeting*, 2002, pp. 305-308.
- [3] R. H. Lasseter and P. Paigi, "Microgrid: A conceptual solution," in *Proc. IEEE power electro special conf.*, 2004, pp.4285-4290.
- [4] J. Rocabert, A. Luna, F. Blaabjerg, and P. Rodriguez, "Control of power converters in AC microgrids," *IEEE Trans. Power Electron.*, vol.27, no.11, pp.4734-4739, Nov.2012.
- [5] A. Molderink, V. Bakker, M. G. C. Bosman, J. L. Hurink, and G. J. M. Smit, "Management and control of domestic smart grid technology," *IEEE Trans. Smart Grid*, vol.1, no.2, pp.109-119, Sep.2010.
- [6] K. Debrabandere, B. Bolsens, J. Van den Keybus, A. Woyte, J. Driesen, and R. Belmans, "A voltage and frequency droop control method for parallel inverters," *IEEE Trans. Power Electron.*, vol.22, no.4, pp.1107-1115, Jul.2007.
- [7] F. Blaabjerg, R. Teodorescu, M. Liserre, and A. V. Timbus, "Overview of control and grid synchronization for distributed power generation systems," *IEEE Trans. Ind. Electron*, vol.53, no.5, pp.1398-1409, Oct.2006.
- [8] J. J. Justo, F. Mwasilu, and J. Lee, "AC microgrids versus DC microgrids with distributed energy resources: A review," *Renewable and Sustainable Energy Reviews*, vol.24, pp.387-405, Aug.2013.
- [9] M. A. Eltawil, and Z. Zhao, "Grid-connected photovoltaic power systems: Technical and potential problems-A review," *Renewable and Sustainable Energy Reviews*, vol.14, no.1 pp.112-129, Jan.2010.
- [10] Y. Li, D. M. Vilathgamuwa, and P.C. Loh, "Design, analysis, and real-time testing of a controller for multi-bus microgrid system," *IEEE*

- Trans. on Power Electron.*, vol.19, no.5, pp.1195-1204, Sep.2004.
- [11] P. Piagi and R. H. Lasseter, "Autonomous control of microgrids," in *Proc. Power Engineering Society General Meeting*, 2006, pp.8-15.
- [12] P. Arbolea, D. Diaz, and J. M. Guerrero, "An improved control scheme based in droop characteristic for microgrid converters," in *Proc. Electric power systems research*, 2010, pp.1215-1221.
- [13] J. A. P. Lopes, C. L. Moreira, and A. G. Madureira, "Defining control strategies for microgrids islanded operation," *IEEE Trans. Power Syst.*, vol.21, no.2, pp.916-924, May 2006.
- [14] F. Katiraei, M. R. Iravani, and P. W. Lehn, "Micro-grid autonomous operation during and subsequent to islanding process," *IEEE Trans. Power Del.*, vol.20, no.1, pp.248-257, Jan. 2005.
- [15] N. Lidula and A. Rajapakse, "Microgrids research: a review of experimental microgrids and test systems," *Renewable and Sustainable Energy Reviews*, vol.15, no.1, pp.186-202, Jan.2011.
- [16] M. C. Chandorkar, D. M. Divan, and R. Adapa, "Control of parallel connected inverters in standalone ac supply systems," *IEEE Trans. Ind. Appl.*, vol.29, no.1 pp.136-143, Jan.1993.
- [17] M. C. Chandorkar, D. M. Divan, and B. Blaabjerg, "Control of distributed UPS systems," in *Proc. 25th Annual IEEE Power Electron. Specialists Conf.*, 1994, pp.197-204.
- [18] Y. B. Byun, T. G. Koo, and K. Y. Joe, "Parallel operation of three-phase UPS inverters by wireless load sharing control," in *Proc. Telecommunications Energy Conf.*, 2000, pp.526-532.
- [19] J. M. Guerrero, L. GarcíadeVicuna, and J. Matas, "Output impedance design of parallel-connected UPS inverters with wireless load-sharing control," *IEEE Trans. Ind. Electron.*, vol.52, no.4, pp.1126-1135, Aug.2005.
- [20] J. M. Guerrero, L. Hang, and J. Uceda, "Control of distributed uninterruptible power supply systems," *IEEE Trans. Ind. Electron.*, vol.55, no.8, pp.2845-2859, Aug.2008..
- [21] J. M. Guerrero, J. C. Vasquez, and J. Matas, "Control strategy for flexible microgrid based on parallel line-interactive UPS systems," *IEEE Trans. Ind. Electron.*, vol.56, no.3, pp.726-736, Mar.2009.
- [22] T. L. Vandoorn, J. D. M. De Kooning, and B. Meersman, "Review of primary control strategies for islanded microgrids with power-electronic interfaces," *Renewable and Sustainable Energy Reviews*, vol.19, pp.613-628, Mar.2013.
- [23] D. Shanxu, M. Yu, and X. Jian, "Parallel operation control technique of voltage source inverters in UPS," in *Proc. of the IEEE 1999 International Conf.* 1999, pp.883-887.
- [24] M. Prodanovic, T. C. Green, and H. Mansir, "A survey of control methods for three-phase inverters in parallel connection," in *Proc. 8th International Conf. Power Electron. and Variable Speed Drives*, 2000, pp. 472-477.
- [25] K. Siri, C. Q. Lee, and T. F. Wu, "Current distribution control for parallel connected converters part ii," *IEEE Trans. Aerospace and Electronic Syst.*, vol.28, pp.841-851, Jul.1992.
- [26] T. F. Wu, K. Siri, and J. Banda, "The central-limit control and impact of cable resistance in current distribution for parallel-connected DC-DC converters," in *Proc. 25th Annual IEEE Power Electron. Specialists Conf.*, 1994, pp.694-702.
- [27] J. Banda and K. Siri, "Improved central-limit control for parallel operation of DC-DC power converters," in *Proc. 26th Annual IEEE Power Electron. Specialists Conf.*, 1995, pp.1104-1110.
- [28] K. Siri, C. Q. Lee, and T. E. Wu, "Current distribution control for parallel connected converters I," *IEEE Trans. Aerospace and Electronic Syst.*, vol.28, no.3, pp.829-840, Jul.1992.
- [29] J. F. Chen and C. L. Chu, "Combination voltage-controlled and current-controlled PWM inverters for UPS parallel operation," *IEEE Trans. Power Electron.*, vol.10, no.5, pp.547-558, Sep.1995.
- [30] F. Petruzzello, P. D. Ziogas, and G. Joos, "A novel approach to paralleling of power converter units with true redundancy," in *Proc. 21st Annual IEEE Power Electron. Specialists Conf.* 1990, pp.808-813.
- [31] Y. Pei, G. Jiang, and X. Yang, "Auto-master-slave control technique of parallel inverters in distributed AC power systems and UPS," in *Proc. 35th Annual IEEE Power Electron. Specialists, 2004*, pp. 2050-2053.
- [32] J. Tan, H. Lin, and J. Zhang, "A novel load sharing control technique for paralleled inverters," in *Proc. 34th Annual IEEE Power Electron. Specialist Conf.*, 2003, pp.1432-1437.
- [33] X. Sun, Y. S. Lee, and D. Xu, "Modeling, analysis, and implementation of parallel multi-inverter systems with instantaneous average current sharing scheme," *IEEE Trans. Power Electron.*, vol.18, no.3, pp.844-856, May 2003.
- [34] J. He and Y. W. Li, "An Enhanced Microgrid Load Demand Sharing Strategy," *IEEE Trans. Power Electron.*, vol.27, no.9, pp.3984-3995, Sep.2012.
- [35] A. Tuladhar, H. Jin, and T. Unger, "Parallel operation of single phase inverter modules with no control interconnections," in *Proc. of Twelfth Annual IEEE Applied Power Electron. and Exposition*, 1997, pp.94-100.
- [36] A. Tuladhar, H. Jin, and T. Unger, "Control of parallel inverters in distributed AC power systems with consideration of line impedance effect," *IEEE Trans. Ind. Appl.*, vol.36, no.1, pp.131-138, Jan.2000.
- [37] J. C. Vasquez, J. M. Guerrero, and A. Luna, "Adaptive droop control applied to voltage-source inverters operating in grid-connected and islanded modes," *IEEE Trans. Ind. Electron.*, vol.56, no.10, pp.4088-4096, Oct.2009.
- [38] Y. W. Li and C. N. Kao, "An accurate power control strategy for power-Electronic-interfaced distributed generation units operating in a low-voltage multibus microgrid," *IEEE Trans. Power Electron.*, vol.24, no.12, pp.2977-2988, Dec.2009.
- [39] P. H. Divshali, A. Alimardani, and S. H. Hosseini, "Decentralized cooperative control strategy of microsources for stabilizing autonomous VSC-based microgrids," *IEEE Trans. Power Syst.*, vol.24, no.4, pp.1949-1959, Nov.2012.
- [40] F. Katiraei and M. R. Iravani, "Power management strategies for a microgrid with multiple distributed generation units," *IEEE Trans. Power Syst.*, vol.21, no.4, pp.1821-1831, Nov.2006.
- [41] E. A. A. Coelho, P. C. Cortizo, and P. F. D. Garcia, "Small-signal stability for parallel-connected inverters in stand-alone AC supply systems," *IEEE Trans. Ind. Appl.*, Mar.2002;38(2):533-42.
- [42] N. Pogaku, M. Prodanovic, and T. C. Green, "Modeling, analysis and testing of autonomous operation of an inverter-based microgrid," *IEEE Trans. Power Electron.*, vol.22, no.2, pp.613-625, Mar.2007.
- [43] R. Majumder, A. Ghosh, and G. Ledwich, "Angle droop versus frequency droop in a voltage source converter based autonomous microgrid," in *Proc. Power & Energy Society General Meeting*, 2009, pp.1-8.
- [44] R. Majumder, B. Chaudhuri, and A. Ghosh, "Improvement of stability and load sharing in an autonomous microgrid using supplementary droop control loop," *IEEE Trans. Power Syst.*, vol.25, no.2, pp.796-808, May.2010.
- [45] R. Majumder, G. Ledwich, and A. Ghosh, "Droop control of converter-interfaced microsources in rural distributed generation," *IEEE Trans. Power Del.*, vol.25, no.4, pp.2768-2778, Oct.2010.
- [46] J. M. Guerrero, J. Matas, and L. G. de Vicuña, "Decentralized control for parallel operation of distributed generation inverters using resistive output impedance," *IEEE Trans. Ind. Electron.*, vol.54, no.2, pp.994-1004, Apr.2007.
- [47] X. Yu, A. M. Khambadkone, and H. Wang, "Control of parallel-connected power converters for low-voltage microgrid—Part I: A hybrid control architecture," *IEEE Trans. Power Electron.*, vol.25, no.12, pp.2962-2970, Dec.2010.
- [48] C. K. Sao and P. W. Lehn, "Control and power management of converter fed microgrids," *IEEE Trans. Power Syst.*, vol.23, no.3, pp.1088-1098, Aug.2008.
- [49] T. L. Vandoorn, B. Meersman, and L. Degroote, "A control strategy for islanded microgrids with dc-link voltage control," *IEEE Trans. Power Del.*, vol.26, no.2, pp.703-713, Apr.2011.
- [50] T. L. Vandoorn, B. Renders, and L. Degroote, "Active load control in

- islanded microgrids based on the grid voltage," *IEEE Trans. Smart Grid*, vol.2, no.1, pp.139-151, Mar.2011.
- [51] T. L. Vandoom, B. Meersman, and J. De Kooning, "Automatic power sharing modification of P/V droop controllers in low-voltage resistive microgrids," *IEEE Trans. Power Del.*, vol.27, no.4, pp.2318-2325, Oct.2012.
- [52] A. Moawwad, V. Khadkikar, and J. L. Kirtley, "A New P-Q-V Droop Control Method for an Interline Photovoltaic (I-PV) Power System," *IEEE Trans. Power Del.*, vol.28, no.2, pp.658-668, Apr.2013.
- [53] W. Yao, M. Chen, and J. Matas, "Design and analysis of the droop control method for parallel inverters considering the impact of the complex impedance on the power sharing," *IEEE Trans. Ind. Electron.*, vol.58, no.2, pp.576-588, Feb.2011.
- [54] J. C. Vasquez, J. M. Guerrero, and A. Luna, "Adaptive droop control applied to voltage-source inverters operating in grid-connected and islanded modes," *IEEE Trans. Ind. Electron.*, vol.56, no.10, pp.4088-4096, Oct.2009.
- [55] H. Hanaoka, M. Nagai, and M. Yanagisawa, "Development of a novel parallel redundant UPS," in *Proc. the 25th International IEEE Telecommunications Energy Conf.* 2003, pp.493-498.
- [56] J. M. Guerrero, L. G. de Vicuña, and J. Matas, "A wireless controller to enhance dynamic performance of parallel inverters in distributed generation systems," *IEEE Trans. Power Electron.*, vol.19, no.5, pp.1205-1213, Sep.2004.
- [57] G. Yajuan, W. Weiyang, and G. Xiaoqiang, "An improved droop controller for grid-connected voltage source inverter in microgrid," in *Proc. the 2nd IEEE International Symposium on Power Electron. for Distrib. Gen. Syst.*, 2010, pp.823-828.
- [58] Y. Mohamed and E. F. El-Saadany, "Adaptive decentralized droop controller to preserve power sharing stability of paralleled inverters in distributed generation microgrids," *IEEE Trans. Power Electron.*, vol.23, no.6, pp.2806-2816, Nov.2008.
- [59] A. M. Salamah, S. J. Finney, and B. W. Williams, "Autonomous controller for improved dynamic performance of AC grid, parallel-connected, single-phase inverters," *IET Gen., Trans. Distrib.*, vol.2, no.2, pp.209-218, Mar.2008.
- [60] T. Goya, E. Omine, and Y. Kinjo, "Frequency control in isolated island by using parallel operated battery systems applying  $H_\infty$  control theory based on droop characteristics," *IET Renewable Power Gen.*, vol.5, no.2, pp.160-166, Mar.2011.
- [61] J. M. Guerrero, J. C. Vasquez, and J. Matas, "Hierarchical control of droop-controlled AC and DC microgrids—A general approach toward standardization," *IEEE Trans. Ind. Electron.*, vol.58, no.1, pp.158-172, Jan.2011.
- [62] J. M. Guerrero, P. Loh, and M. Chandorkar, "Advanced Control Architectures for Intelligent MicroGrids—Part I: Decentralized and Hierarchical Control," *IEEE Trans. Ind. Electron.*, vol.60, no.4, pp.1254-1262, Apr.2013.
- [63] J. He, Y. W. Li, and J. M. Guerrero, "An Islanding Microgrid Power Sharing Approach Using Enhanced Virtual Impedance Control Scheme," *IEEE Trans. Power Electron.*, vol.28, no.11, pp.5272-5282, Nov.2013.
- [64] J. He and Y. W. Li, "Analysis, design, and implementation of virtual impedance for power Electron," interfaced distributed generation. *IEEE Trans. Ind. Appl.*, vol.47, no.6, pp.2525-2538, Nov.2011.
- [65] C. T. Lee, C. C. Chuang, and C. C. Chu, "Control strategies for distributed energy resources interface converters in the low voltage microgrid," in *Proc. IEEE Energy Conversion Congress and Exposition*, 2009, pp.2022-2029.
- [66] Y. Li and Y. W. Li, "Decoupled power control for an inverter based low voltage microgrid in autonomous operation," in *Proc. IEEE 6th International Power Electron. and Motion Control*, 2009, pp.2490-2496.
- [67] Y. Li and Y. W. Li, "Virtual frequency-voltage frame control of inverter based low voltage microgrid," in *Proc. IEEE Electrical Power & Energy Conf.* 2009, pp.1-6.
- [68] Y. Li and Y. W. Li, "Power management of inverter interfaced autonomous microgrid based on virtual frequency-voltage frame," *IEEE Trans. Smart Grid*, vol.2, no.1, pp.30-40, Mar.2011.
- [69] E. Rokrok and M. E. H. Golshan, "Adaptive voltage droop scheme for voltage source converters in an islanded multi-bus microgrid," *IET generation, trans. distrib.*, vol.4, no.5, pp.562-578, May.2010.
- [70] J. He and Y. W. Li, "An accurate reactive power sharing control strategy for DG units in a microgrid," in *Proc. IEEE 8th International Conf. Power Electron. and ECCE Asia*, 2011, pp.551-556.
- [71] J. He and Y. W. Li, "An Enhanced Microgrid Load Demand Sharing Strategy," *IEEE Trans. Power Electron.*, vol.27, no.9, pp.3984-3995, Sep.2012.
- [72] C. T. Lee, C. C. Chu, and P. T. Cheng, "A new droop control method for the autonomous operation of distributed energy resource interface converters," in *Proc. IEEE Energy Conversion Congress and Exposition*, 2010, pp.702-709.
- [73] C. T. Lee, C. C. Chu, and P. T. Cheng, "A New Droop Control Method for the Autonomous Operation of Distributed Energy Resource Interface Converters," *IEEE Trans. Power Electron.*, vol.28, no.4, pp.1980-1993, Apr.2013.
- [74] C. T. Lee, R. P. Jiang, and P. T. Cheng, "A grid synchronization method for droop controlled distributed energy resources converters," in *Proc. IEEE Energy Conversion Congress and Exposition*, 2011, pp.743-749.
- [75] C. K. Sao and P. W. Lehn, "Autonomous load sharing of voltage source converters," *IEEE Trans. Power Del.*, vol.20, no.2, pp.1009-1016, Apr.2005.
- [76] Q. C. Zhong, "Robust droop controller for accurate proportional load sharing among inverters operated in parallel," *IEEE Trans. Ind. Electron.*, vol.60, no.4, pp.1281-1290, Apr.2013.
- [77] D. J. Perreault, R. L. Selders Jr, and J. G. Kassakian, "Frequency-based current-sharing techniques for paralleled power converters," *IEEE Trans. Power Electron.*, vol.13, no.4, pp.626-634, Jul.1998.
- [78] A. Bidram and A. Davoudi, "Hierarchical structure of microgrids control system," *IEEE Trans. Smart Grid*, vol.3, no.4, pp.1963-1976, Dec.2012.
- [79] E. Mojica-Nava, C. A. Macana, and N. Quijano, "Dynamic population games for optimal dispatch on hierarchical microgrid control," *IEEE Trans. Syst., Man, and Cybernetics: Systems*, Vol.44, No.3, pp.306-317, Mar.2014.
- [80] L. Meng, F. Tang, M. Savaghebi, J. C. Vasquez, and J. M. Guerrero, "Tertiary Control of Voltage Unbalance Compensation for Optimal Power Quality in Islanded Microgrids," *IEEE Trans. Energy Conv.*, Vol.29, No.4, pp.802-815, Dec.2014.
- [81] F. Shahnia, R. P. S Chandrasena, S. Rajakaruna, and A. Ghosh, "Primary control level of parallel distributed energy resources converters in system of multiple interconnected autonomous microgrids within self-healing networks," *IET Gen., Trans. and Distrib.*, Vol.8, No.2, pp.203-222, Feb.2014.
- [82] J. Bingnan, and F. Yunsi, "Smart Home in Smart Microgrid: A Cost-Effective Energy Ecosystem with Intelligent Hierarchical Agents," *IEEE Trans. Smart Grid*, Vol.6, No.1, pp.3-13, Jan.2015.
- [83] X. Wu, W. Xiuli, and Q. Chong, "A Hierarchical Framework for Generation Scheduling of Microgrids," *IEEE Trans. Power Del.*, Vol.29, No.6, pp.2448-2457, Dec.2014.
- [84] D. E. Olivares, A. Mehrizi-Sani, A. H. Etemadi, C. A. Cañizares, R. Iravani, M. Kazerani, A. H. Hajimiragha, O. Gomis-Bellmunt, M. Saeedifard, R. Palma-Behnke, G. A. Jiménez-Estévez, and N. D. Hatziargyriou, "Trends in microgrid control," *IEEE Trans. Smart Grid*, Vol.5, No.4, pp.1905-1919, Jul.2014.
- [85] M. Yazdani and A. Mehrizi Sani, "Distributed Control Techniques in Microgrids," *IEEE Trans. Smart Grid*, Vol.5, No.6, pp.2901-2909, Nov.2014.
- [86] M. A. shabani and Y. A. I. Mohamed, "New Family of Microgrid Control and Management Strategies in Smart Distribution Grids—Analysis, Comparison and Testing," *IEEE Trans. Power Syst.*, Vol.29, No.5, pp.2257-2269, Sep.2014.
- [87] B. M. Eid, N. A. Rahim, J. Selvaraj, and A. H. El Khateb, "Control methods and objectives for electronically coupled distributed energy resources in microgrids: a review," *IEEE Syst. J.*, pp.1-13, 2014.
- [88] M. M. A. Abdelaziz, M. F. Shaaban, H. E. Farag, and E. F. El-Saadany, "A multistage centralized control scheme for islanded microgrids with PEV," *IEEE Trans. Sustainable Energy*, Vol.5, No.3, pp.927 – 937, Jul. 2014.

- [89] T. Caldognetto, and T. Paolo, "Microgrids Operation Based on Master-Slave Cooperative Control," *IEEE Journal of Emerging and Selected Topics in Power Electron.*, Vol.2, No.4, pp.1081 – 1088, Dec.2014.
- [90] Q. Shafiee, J. M. Guerrero, and V. C. Juan, "Distributed secondary control for islanded microgrids—A novel approach," *IEEE Trans. Power Electron.*, Vol.29, No.2, pp.1018 –1031, Feb.2014.
- [91] A. Bidram, A. Davoudi, and F. Lewis, "A Multi-objective Distributed Control Framework for Islanded AC Microgrids," *IEEE Trans. Ind. Informatics*, Vol.10, No.3, pp.1785 – 1798, Aug. 2014.
- [92] H. Xin, L. Zhang, Z. Wang, D. Gan, and K. P. Wong, "Control of Island AC Microgrids Using a Fully Distributed Approach," *IEEE Trans. Smart Grid*, Vol.6, No.2, pp.943 – 945, Mar.2015.
- [93] M. A. Mahmud, M. J. Hossain, H. R. Pota, and A. M. T. Oo, "Robust Nonlinear Distributed Controller Design for Active and Reactive Power Sharing in Islanded Microgrids," *IEEE Trans. Energy Conv.*, Vol.29, No.4, pp.893-903, Dec.2014.
- [94] J. Hu, J. Zhu, D. G. Dorrell, and J. M. Guerrero, "Virtual Flux Droop Method—A New Control Strategy of Inverters in Microgrids," *IEEE Trans. Power Electron.*, Vol.29, No.9, pp.4704-4711, Sep.2014.
- [95] M. Ashabani, Y. Mohamed, M. Mirsalim, and M. Aghashabani, "Multivariable Droop Control of Synchronous Current Converters in Weak Grids/Microgrids With Decoupled textit {dq}-Axes Currents," *IEEE Trans. Smart Grid*, to be published.
- [96] L. Y. Lu, and C. C. Chu, "Consensus-Based Droop Control Synthesis for Multiple DICs in Isolated Micro-Grids," *IEEE Trans. Power Systems*, to be published.
- [97] X. Yu, A. M. Khambadkone, and H. H. Wang, "A hybrid control architecture for low voltage microgrid," in *Proc. IEEE Energy Conversion Congress and Exposition*, 2010, pp.3161-3168.
- [98] Y. Zhang and H. Ma, "Theoretical and experimental investigation of networked control for parallel operation of inverters," *IEEE Trans. Ind. Electron.*, vol.59, no.4, pp.1961-1970, Apr.2012.
- [99] M. N. Marwali, J. W. Jung, and A. Keyhani, "Control of distributed generation systems-Part II: Load sharing control," *IEEE Trans. Power Electron.*, vol.19, no.6, pp.626-634, Nov.2004.
- [100] H. Hua, L. Yao, S. Yao, S. Mei, and J. M. Guerrero, "An Improved Droop Control Strategy for Reactive Power Sharing in Islanded Microgrid," *IEEE Trans. Power Electron.*, Vol.30, No.6, pp.3133-3141, Jun.2014.
- [101] A. Kahrobaei and Y. Abdel-Rady Ibrahim Mohamed, "Networked Based Hybrid Distributed Power Sharing and Control for Islanded Micro-Grid Systems," *IEEE Trans. Power Electron.*, Vol.30, No.2, pp.603-617, Feb.2015
- [102] A. Vargas-Martínez, L. I. Avila Minchala, Y. Zhang, L. E. Garza-Castañón, and H. Badihi, "Hybrid Adaptive Fault-Tolerant Control Algorithms for Voltage and Frequency Regulation of an Islanded Microgrid," *Int. Trans. Electron. Energ. Syst.*, Jan.2014.
- [103] I. U. Nutkani, P. C. Loh, and F. Blaabjerg, "Cost-Prioritized Droop Schemes for Autonomous AC Microgrids," *IEEE Trans. Power Electron.*, Vol.30, No.2, pp.1109-1119, Feb.2015.



**Hua Han** received the M.S. and Ph.D. degrees from the School of Information Science and Engineering, Central South University, Changsha, China, in 1998 and 2008, respectively. She was a visiting scholar of University of Central. Florida, Orlando, FL, USA, from April 2011 to April 2012. She is currently an associate professor with the School of Information Science and Engineering, Central South University, China. Her research interests include microgrid, and power electronic equipment.

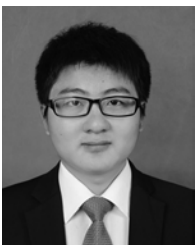

**Xiaochao Hou** received the B.S. degree in Automation from the Central South University, Changsha, China, in 2014, where he is currently working toward M.S. degree in electrical engineering.

His research interests include Renewable Energy Systems, Distributed generation and micro-grid.

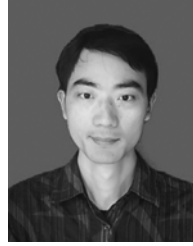

**Jifa Wu** received the B.S. and M.S. degrees from the School of Information Science and Engineering, Central South University, Changsha, China, in 2006 and 2009, respectively, where he is currently working toward Ph.D. degree in electrical engineering.

His research interests include photovoltaic power generation system and wind energy conversion system.



**Mei Su** received the B.S., M.S. and Ph.D. degrees from the School of Information Science and Engineering, Central South University, Changsha, China, in 1989, 1992 and 2005, respectively.

Since 2006, She has been a Professor with the School of Information Science and Engineering, Central South University. Her research interests include matrix converter, adjustable speed drives, and wind energy conversion system.



**Jian Yang** (M'09) received the Ph.D. degree in electrical engineering from the University of Central Florida, Orlando, in 2008. He was a Senior Electrical Engineer been with Delta Tau Data Systems, Inc., Los Angeles, CA, from 2007 to 2010.

Since 2011, he has been with Central South University, Changsha, China, where he is currently an Associate Professor with the School of Information Science and Engineering. His main research interests include control application, motion planning, and power electronics.



**Josep M. Guerrero** (S'01-M'04-SM'08-F'15) received the B.S. degree in telecommunications engineering, the M.S. degree in electronics engineering, and the Ph.D. degree in power electronics from the Technical University of Catalonia, Barcelona, in 1997, 2000 and 2003, respectively.

Since 2011, he has been a Full Professor with the Department of Energy Technology, Aalborg University, Denmark, where he is responsible for the Microgrid Research Program. Since 2012 he has been a guest Professor at the Chinese Academy of Science and the Nanjing University of Aeronautics and Astronautics; and since 2014, he has been chair Professor in Shandong University. His research interests is oriented to different microgrid aspects, including power electronics, distributed energy-storage systems, hierarchical and cooperative control, energy management systems, and optimization of microgrids and islanded minigrids.

Prof. Guerrero is an Associate Editor for the IEEE TRANSACTIONS ON POWER ELECTRONICS, the IEEE TRANSACTIONS ON INDUSTRIAL ELECTRONICS, and the IEEE Industrial Electronics Magazine, and an Editor for the IEEE TRANSACTIONS ON SMART GRID. He has been Guest Editor of the IEEE TRANSACTIONS ON POWER ELECTRONICS Special Issues: Power Electronics for Wind Energy Conversion and Power Electronics for Microgrids; the IEEE TRANSACTIONS ON INDUSTRIAL ELECTRONICS Special Sections: Uninterruptible Power Supplies systems, Renewable Energy Systems, Distributed Generation and Microgrids, and Industrial Applications and Implementation Issues of the Kalman Filter; and the IEEE TRANSACTIONS ON SMART GRID Special Issue on Smart DC Distribution Systems. He was the chair of the Renewable Energy Systems Technical Committee of the IEEE Industrial Electronics Society. In 2014 he was awarded as ISI Highly Cited Researcher, and in 2015 he was elevated as IEEE Fellow for his contributions on "distributed power systems and microgrids".