



**AALBORG UNIVERSITY**  
DENMARK

**Aalborg Universitet**

## **Economic Operation of Power Systems with Significant Wind Power Penetration**

Farashbashi-Astaneh, Seyed-Mostafa

*Publication date:*  
2015

*Document Version*  
Publisher's PDF, also known as Version of record

[Link to publication from Aalborg University](#)

*Citation for published version (APA):*  
Farashbashi-Astaneh, S-M. (2015). Economic Operation of Power Systems with Significant Wind Power Penetration. Department of Energy Technology, Aalborg University.

### **General rights**

Copyright and moral rights for the publications made accessible in the public portal are retained by the authors and/or other copyright owners and it is a condition of accessing publications that users recognise and abide by the legal requirements associated with these rights.

- ? Users may download and print one copy of any publication from the public portal for the purpose of private study or research.
- ? You may not further distribute the material or use it for any profit-making activity or commercial gain
- ? You may freely distribute the URL identifying the publication in the public portal ?

### **Take down policy**

If you believe that this document breaches copyright please contact us at [vbn@aub.aau.dk](mailto:vbn@aub.aau.dk) providing details, and we will remove access to the work immediately and investigate your claim.

# **ECONOMIC OPERATION OF POWER SYSTEMS WITH SIGNIFICANT WIND POWER PENETRATION**

**By**

**Syedmostafa Farashbashiastaneh**

**Department of Energy Technology**



**AALBORG UNIVERSITY**  
DENMARK

**A Dissertation Submitted to**

**The Faculty of Engineering, Science and Medicine, Aalborg University**

**In partial Fulfilment for the Degree of Doctor of Philosophy**

**March 2015**

**Aalborg, Denmark**

**Aalborg University**

**Department of Energy Technology**

**Pontoppidanstræde 101**

**9220 Aalborg East, Denmark**

**Copyright© Seyedmostafa Farashbashiastaneh, 2015**

**ISBN: 978-87-92846-69-3**

**Printed in Denmark by Aalborg University**

## Mandatory Page

### Thesis Title:

Economic Operation of Power Systems with Significant Wind Power Penetration

### Name of PhD Student:

Syedmostafa Farashbashiastaneh (Mostafa F. Astaneh)

### Name and title of supervisor and any other supervisors

Professor Zhe Chen

Dr. Weihao Hu

### List of publications

- [1] Mostafa F. Astaneh; Zhe Chen; Mousavi, O.A., "Excessive price reduction and extreme volatility in wind dominant electricity markets; solutions and emerging challenges," *Power and Energy Society General Meeting (PES), IEEE* , 21-25 July 2013.
- [2] Mostafa F. Astaneh; Rather, Z.H.; Weihao Hu; Zhe Chen, "Economic valuation of reserves on cross border interconnections; A Danish case study," *Power and Energy Society General Meeting (PES), IEEE* , 27-31 July 2014.
- [3] Mostafa F. Astaneh; Hu, Weihao; Chen, Zhe, "Cooperative optimal operation of wind-storage facilities," *Power and Energy Engineering Conference (APPEEC), 2014 IEEE PES Asia-Pacific*, 7-10 Dec. 2014.
- [4] Mostafa F. Astaneh, Bishnu P. Bhattarai, Birgitte Bak-Jensen, Weihao Hu, Jayakrishnan R. Pillai, Zhe Chen, " A Novel Technique to Enhance Demand Response: an EV-based Test Case", Accepted in *IEEE PES IREC (6<sup>th</sup> International Renewable Energy Conference)*, 2015, Tunisia.
- [5] Mostafa F. Astaneh, Weihao Hu, Zhe Chen, "A Comparative Study between Two Market Clearing Schemes in Wind Dominant Electricity Markets", *IET Generation, Transmission & Distribution*.
- [6] Mostafa F. Astaneh, Weihao Hu, Zhe Chen, " Coordinated Operation of Wind-Storage Facilities Considering Power System Balancing Conditions", *IET Generation Transmission & Distribution*, Special Issue of Optimal Utilization of Storage Systems in Transmission and Distribution Systems (status: under review).
- [7] Mostafa F. Astaneh, Zakir Hussain Rather, Weihao Hu, Zhe Chen "Reserve Scheduling Considering Environmental Impact of Reserve Service Providers", *Elsevier International Journal of Electrical Power and Energy Systems* (status: under review).
- [8] Mostafa F. Astaneh, Weihao Hu, Zhe Chen, "Risk-Based Quantifying of Reserve Requirement in Wind Dominant Power Systems", *Elsevier International Journal of Electrical Power and Energy Systems* (status: under review).
- [9] Mostafa F. Astaneh; Zhe Chen, "Price volatility in wind dominant electricity markets," *IEEE EUROCON*, 1-4 July 2013.



This present report combined with the above listed scientific papers has been submitted for assessment in partial fulfilment of the PhD degree. The scientific papers are not included in this version due to copyright issues. Detailed publication information is provided above and the interested reader is referred to the original published papers. As part of the assessment, co-author statements have been made available to the assessment committee and are also available at the Faculty of Engineering and Science, Aalborg University.

## Acknowledgment

This work is carried out within the project of Development of a Secure, Economic, and Environmentally-friendly Modern Power System (SEEMPS) supported by The Danish Council for Strategic Research (DSF 09-067225). I would like to thank them for their financial support.

I would like to thank my supervisor Professor Zhen Chen for his kindness, patience, suggestions, and encouragement through this PhD study. His continues support, understanding, and knowledge transferring have been very important in completing this research work. I would also like to thank Dr. Weihao Hu, who was my co-supervisor in this project and helped me a lot through fruitful technical discussions in the course of this PhD.

I would like to thank the steering committee members, which provided me with invaluable comments and suggestions in the project meetings. This goes especially to Brigitte Back Jensen, Per Lund, Claus Leth Bak, Paul Thøgersen, John K. Pederson, Alan Jensen, Brian Kirby and Katrine Bech Andersen.

I would like to thank other PhD students in the research group, especially Zakir Hussain Rather, Pietro Raboni, Iker Mendaza, Chengxi Liu, Jiakun Fang, Nuri Gokmen and Bishnu Prasad Bhattarai for helpful discussions and nice collaborations. I also would like to Thank Assistant Professor Hamed Mohsenian-Rad and his PhD students at Smart Grid Research Lab at University of California Riverside for their suggestions and constructive comments on my research work. I thank all my other friends and colleagues in the Department of Energy Technology for their moral support and encouragement.

Last but not least, I wish to thank all whole my family for their love and constant support. I specially thank my wife, Aida, for being my best friend and endless hope.

Syedmostafa Farashbashiastaneh

March 1<sup>st</sup>, 2015

Aalborg-Denmark



## Abstract

This dissertation addresses economic operation of power systems with high penetration of wind power. Several studies are presented to address the economic operation of power systems with high penetration of variable wind power. The main concern in such power systems is high variability and unpredictability. Unlike conventional power plants, the output power of a wind farm is not controllable. This brings additional complexity to operation and planning of wind dominant power systems. The key solution in face of wind power uncertainty is to enhance power system flexibility. The enhanced flexibility level should be economic and can be provided by different tools such as developing new reserve scheduling techniques, demand response, using storage units, facilitating the capacity of cross-border interconnections and so on. These subjects are addressed in this PhD dissertation.

In the first study of this dissertation, a comparative study between uniform and pay-as-bid pricing mechanisms is presented. The average price and the volatility in day-ahead market are compared in two mentioned market clearing approaches. Bidding behavior of generation companies is investigated under two pricing schemes.

Next, cooperative wind-storage operation is studied. Lithium-Ion battery units are chosen as storage units. A novel formulation is proposed to investigate optimal operation of a storage unit considering power system balancing conditions and wind power imbalances.

An optimization framework is presented to increase demand responsiveness. It is argued that the price difference between peak and off-peak hours is not incentivizing enough to encourage load shifting. The key idea is to magnify the price difference between peak and off-peak hours. The result is a new set of prices under which the peak demand is reduced (and thus power system security is enhanced). The optimal charging scheme of Eclectic Vehicles (EVs) in a distribution feeder is then studied considering the proposed pricing scheme.

A formulation is then proposed for optimal reserve scheduling considering the role of reserve provision scenarios from cross-border interconnections. The framework decouples the share of upward and downward primary, secondary, and tertiary reserve services within DK1 (western Danish power system) and neighboring cross border resources (Norway and Germany). Results indicate the economic benefit of reserve provision provided by cross border interconnections.

In another study, a reserve scheduling framework is presented which considers the environmental impact of reserve providers. The impact of considering environmental costs of reserve resources on reserve scheduling is investigated.

## Danske Abstrakt

Denne afhandling omhandler økonomisk drift af el systemer med høj gennem trængning af vindkraft. Flere undersøgelser præsenteres for at opnå på den økonomiske drift af el systemer med høj gennem trængning af variabel vindkraft. Den største bekymring i sådanne kraftsystemer er høj variabilitet og uforudsigelighed. I modsætning til konventionelle kraftværker er udgangseffekten fra en vindmøllepark ikke styrbar. Dette bringer yderligere kompleksitet til drift og planlægning af vind-dominerende el systemer. Nøglen er løsning at usikkerheden med vind-kraft og øge fleksibilitet i el systemer. Det øgede fleksibilitetsniveau bør være økonomisk og kan leveres af forskellige værktøjer som udvikling af nye reserveplanlægningsteknikker, fleksibelt elforbrug ved hjælp af lagerenheder, kapacitet til grænseoverskridende sammenkoblinger og så videre. Øget fleksibilitet i el systemet er den centrale idé i dette forskningsarbejde.

I den første undersøgelse af denne afhandling præsenteres en sammenlignende undersøgelse mellem Uniform og Pay-as-bid prismekanismer. Den gennemsnitlige pris og forskellen mellem det dag-aktuelle marked sammenlignes i to nævnte markedstilgange. Tilbud fra produktionsselskaber undersøges under to prisordninger.

Dernæst studeres kooperativ vind-oplagring. Lithium-Ion batterienheder er valgt som lagerenheder. En ny formulering foreslås til at undersøge optimal drift af en lagerenhed og med hensyn til betingelser for magt systembalance og vindkraft værkers ubalancer.

En ramme for optimering præsenteres for at øge efterspørgslen efter lydhørhed. Det hævdes, at prisforskellen mellem peak og off-peak timer ikke er motiverende nok til at opmuntre skift i belastningen. Den centrale idé er at forstørre prisforskellen mellem peak og off-peak timer. Resultatet er et nyt sæt af priser i henhold til hvilke den maksimale efterspørgsel reduceres (og dermed kraftsystemsikkerheden er øget). Den optimale afgiftsordning af Eclectic Vehicles (EVS) i en fordelingsautomat undersøges derefter for at overveje den foreslåede prissætningsordning.

En formulering foreslås derefter for optimal reserve planlægning at reservekrav for grænseoverskridende sammenkoblinger. Rammerne afkobler andelen af opadgående og nedadgående primære, sekundære og tertiære reserveydelser inden DK1 (western danske el system) og de omkringliggende grænseoverskridende ressourcer (Norge og Tyskland). Resultaterne indikerer den økonomiske fordel af reserve som grænseoverskridende

sammenkoblinger på tværs. I en anden undersøgelse præsenteres en reserveplanlægningsramme som indeholder miljøpåvirkningen af reserveudbydere. Virkningen af miljøomkostningers reserveressourcer på reserveplanlægning undersøges.

## Abbreviations

CHP	Combined Heat and Power
DAM	Day Ahead Market
DG	Distributed Generation
DKK	Danish Kroner
DSM	Demand Side Management
DR	Demand Response
DRA	Demand Response Aggregator
EV	Electric Vehicle
HVDC	High Voltage Direct Current
ISO	Independent System Operator
LDC	Load Duration Curve
LMP	Locational Marginal Price
LOLP	Loss of Load Probability
MAE	Mean Absolute Error
MCP	Market Clearing Price
MCS	Mont Carlo Simulation
MP	Marginal Price



NPE	Net Physical Exchange
PAB	Pay As Bid
PDF	Probability Density Function
SOC	State Of Charge
TSO	Transmission System Operator
VSC	Voltage Source Converter
WSF	Wind Storage Facility

## Table of Contents

Acknowledgment .....	i
Abstract .....	iii
Danske Abstrakt.....	v
Abbreviations .....	vii
Table of Contents .....	ix
Chapter 1 .....	1
Introduction.....	1
1.1 Background and Motivation .....	1
1.2 Research Objectives .....	3
1.3 Contribution of the Thesis .....	4
1.4 Project Limitations .....	4
1.5 Outline of Thesis .....	5
Chapter's References .....	9
Chapter 2.....	10
Analysis of Electricity Market in Denmark .....	10
2.1 Power System Restructuring .....	10
2.2 Nordic Power System and Electricity Market.....	11
2.3 Data Survey in Danish Electricity Market .....	13
2.3.1 Day-Ahead Market Price .....	14
2.3.2 Wind Power Production .....	16
2.3.3 Interconnections with Neighboring Networks .....	19
2.3.4 Consumption .....	23
2.3.5 Price components for End user .....	25
2.4 Summary .....	28
Chapter's References .....	28
Chapter 3.....	29
Market Clearing Schemes in Power systems with Significant Wind Penetration .....	29
3.1 Uniform and pay-as-bid schemes .....	29
3.2 Impact of wind penetration of Electricity Price .....	29
3.3 Price Issues in Electricity Markets with high Wind Penetration .....	31

3.3.1 Agent Based Simulation .....	31
3.3.2 Economic Dispatch .....	32
3.3.3 Modeling the agent based simulation process .....	34
3.3.4 Simulation Results – 5 buses network .....	38
3.3.5 Simulation Results – 24 buses network .....	45
3.4 Discussion .....	55
3.5 Summary .....	57
Chapter’s References .....	58
Chapter 4.....	60
Economic Operation of Wind-Storage Facilities .....	60
4.1 Cooperative operation of wind-storage units .....	60
4.2 Literature review and introduction .....	60
4.3 Storage system role .....	63
4.4 Problem Definition .....	65
4.4.1 Time frame of the optimization framework .....	66
4.4.2 Problem formulation-approach 1 .....	68
4.4.3 Simulation Results-approach 1 .....	74
4.4.4 Problem formulation-approach 2 .....	78
4.4.5 Simulation Results-approach 2 .....	79
4.5 Discussion .....	80
4.6 Summary .....	81
Chapter’s References .....	82
Chapter 5.....	85
Enhanced Demand Responsiveness .....	85
5.1 Demand Response; a flexibility resource .....	85
5.2 Introduction and literature review .....	85
5.3 The role of demand response aggregator .....	89
5.4 Formulation of price modification scheme .....	91
5.5 Simulation results for price modification scheme .....	92
5.6 The impact of new pricing scheme on EV charging .....	96
5.6.1 Optimal EV scheduling .....	98
5.6.2 Integration of the optimal pricing and optimal EV charging .....	100

5.6.3 Simulation configuration .....	100
5.6.4 Simulation for optimal EV scheduling .....	102
5.7 Summary .....	105
Chapter's References .....	106
Chapter 6.....	108
Reserve scheduling considering cross-border interconnections .....	108
6.1 Introduction to existing literature and Danish power system.....	108
6.2 Reserve Market Services in Western Danish Power System .....	110
6.3 Formulation for decoupling different reserve services .....	113
6.3.1 Behavior of reserve procurement cost under different scenarios .....	117
6.4 Summary .....	119
Chapter's References .....	120
Chapter 7 .....	122
Reserve scheduling considering environmental impact of reserve providers .....	122
7.1 Introduction and literature overview .....	122
7.2 Model explanation .....	125
7.3 Robust optimization .....	127
7.4 Problem formulation .....	129
7.5 Simulation results .....	133
7.5.1 Case-I: Without participation of wind farms in reserve service.....	134
7.5.2 Case-II: With participation of wind farms in reserve service .....	138
7.6 Summary .....	142
Chapter's Appendix .....	143
Chapter's References .....	144
Chapter 8.....	147
Conclusion Remarks and Future Work.....	147
8.1 Conclusions .....	148
8.2 Future work .....	149
Chapter's References .....	150



# Chapter 1

## Introduction

### 1.1 Background and Motivation:

Global environmental concerns have urged policy makers to think about alternative ways for electricity generation by means of nature-friendly solutions. During the last two decades, several technologies have been introduced for decarbonizing power systems. Wind, solar, geothermal and tidal are the most known technologies which generate electric power from nature's elements. Among these technologies, wind has the highest percentage in the green power portfolio. Denmark has the highest wind penetration in the world. Wind power is currently about 40% of the installed generation capacity in Denmark. The ambitious target is to provide 50% of the nation's power consumption from wind technology by 2020 and 100% by 2050 [1]. Beside the high wind power penetration, there are also other unique characteristics for Danish power system. One of these special features is the high penetration of distributed generation units which are mainly combined heat and power units. Having the generation units close to load centers decreases the power loss in distribution and transmission networks. Danish power system has been transformed from a centralized power system to a power system with significant number of Distributed Generation (DG) units [2]. Wind farms and Combined Heat and Power (CHP) constitute the majority of these DG units.

Despite having significant advantages, the renewable resources are unpredictable and highly variable [3]. Higher unpredictability level introduces new challenges to power systems operation which traditionally benefited from robust centralized power plants that are perfectly schedulable. The main source of new challenges can be summarized as violation of generation-load balance which is vitally important for maintaining system frequency in the pre-defined range [4]. High frequency deviation can lead to partial or total power outages. These additional challenges can be remedied by adding more flexibility to the power system. There are different sources that can enhance power system flexibility. Following sources can be addressed:

- ***Revising regulations to be compatible for large share of renewable sources;*** this can be revising market regulation to increase power system reliability and security or to encourage future investments.
- ***Implementing storage facilities;*** Storage facilities can absorb electric energy in situations that surplus power is available and can give it back to the grid in deficit conditions. Thus the importance of their role is considerable in power systems with high penetration of renewables. However economic viability of using such facilities in utility level is still questionable.
- ***Increasing demand responsiveness;*** electricity has been traditionally a public service, thus consumers (loads) are not very much sensitive to the changes in electricity price. Transforming the role of loads from passive to active can be a useful tool in the face of high wind power variations and to maintain generation-load balance.
- ***Establishment of interconnections with neighboring grids;*** Interconnections give the system operator the opportunity to access the flexibility resources of the neighboring grids. This will make it possible to benefit from the geographical diversity and the balancing potentials of the neighboring grids.
- ***Introducing new approaches for reserve determination;*** new reserve products can be introduced to hedge the uncertainty of intermittent renewables. This can be novel reserve allocation methodologies while minimizing reserve procurement costs.

Other measures can also enhance power system flexibility, among them increasing units' ramping capabilities and enhanced power system control methods. The added flexibility level should be provided in economic ways, otherwise power system operation costs will be significantly elevated. This will violate one of the most basic arguments in introducing renewables which is making the electric energy more affordable.

This PhD project is to study the economic operation of power systems with high penetration of renewable energy sources. The study first investigates suitable market clearing approaches for power systems with significant wind penetration levels. Optimal Bidding strategies of generation units are studied and market interactions are investigated. Then the impact of different pricing approaches on load responsiveness is investigated. It is shown how an increase in demand responsiveness can be handy in implementing demand side management programs. In addition the impact of demand response on peak shaving and valley filling in distribution systems are studied.

Cooperative operation of wind storage facilities is then studied. The optimal operation of storage units for mitigating wind imbalances is investigated. In addition mathematical models are proposed for optimal reserve scheduling considering different criteria such as using the capacity of cross-border interconnections. The collection of these solutions is an effective tool for empowering power system against the uncertainties arisen by high penetration of wind power. Although not limited to, the main focus of the study is on Danish power system and Nordic market regulations. The concepts and results presented in the PhD thesis can be benefited by Transmission System Operators for bringing more economic optimality to the power system while maintaining security. The parts of the PhD thesis that address optimal bidding strategies of the generation units and also optimal participation of storage facilities can be benefited by private entities which are active in competitive electricity markets.

## **1.2 Research Objectives**

This PhD project is a working package of the mother project “*Development of a Secure, Economic, and Environmentally-Friendly Modern Power System*” which is going on from 2011-2015 at Aalborg University, Department of Energy Technology. The mother project has 6 work tasks. The three-year PhD research project (work task 2) is named “*Optimal Operation of Electricity Market in the Mixed Pattern Power System*” and was initiated by Department of Energy Technology at Aalborg University with collaboration with academic and industrial partners such as Technical University of Denmark and Energinet.dk (Danish TSO). Project leader is Professor Zhe Chen.

The mother project mainly investigates the technicals of high penetration of wind power in Danish power system. The research conducted in this PhD project addresses the different techno economic aspects of high wind penetration of wind power. Specifically, the objectives of this research are as follows:

- 1) To investigate the suitable market clearing approach for electricity markets with high wind penetration.
- 2) To propose ideas for the load to play a more active role to ease higher penetration of wind power.
- 3) To develop models for optimal operation of storage units to ease higher penetration of wind power.



4) To develop probabilistic models for reserve scheduling under high wind penetration.

### **1.3 Contribution of the Thesis**

The focus of the thesis is on the economic aspects of integrating wind power into power system. The main achievements of this PhD project are;

1. Excessive price reduction and extreme volatility are introduced as two emerging problems in electricity markets with significant wind penetration. A comparative study has been conducted under uniform and pay-as-bid pricing mechanisms. Agent based simulation methodology is implemented. The results indicate that pay as bid pricing approach can avoid excessive price reduction. It is also capable of reducing elevated price volatility in power systems with high wind penetration.

2. A price based approach is proposed by which Demand Response Aggregator (DRA) can increase demand responsiveness and shift the load from peak to off-peak hours. The price elasticity of different load types is taken into account. The impact of reduced peak load on power system reliability is investigated. Price data of Nordic electricity market is used.

3. Optimal cooperative operation of a wind-storage facility for mitigating wind imbalance and participation in regulation service is investigated. Optimal cross-arbitrage opportunities are studied.

4. An optimization framework is proposed to minimize reserve costs considering reserve resources from cross-border interconnections. A Danish case-study is presented. In the optimization framework different reserve products (primary, secondary, and tertiary) are decoupled and the share of each reserve product from different sources is determined.

5. Also an optimization framework is proposed for determining the share of reserve providers considering their environmental impact.

### **1.4 Project Limitations**

The limitations of the project in different sections are as follows:

The first research question addresses the functionality of different market clearing approaches. To answer this question a comparative study between marginal and pay-as-bid market clearing approaches in day-ahead market is conducted. As the focus in this study is on investigating the generation bidding behavior, the load is considered to be fixed and inelastic. Considering load elasticity can lead to relatively different market outcomes.

The second research question asks for novel pricing approaches for increasing the load responsiveness. A new pricing approach is proposed to encourage participation in demand response. It is assumed the cross elasticity of demand for different hours is zero. The proposed model considers only the own-price elasticity for each hour. In addition for the time being, consumers will not have the spot market price as their price, thus the real expected fluctuation in the price will be lower due to overhead taxes.

The third research question addresses developing models for optimal storage facilities. Battery depreciation is not taken into account in this study. Keeping in mind the considerable investment size for battery systems it is important that depreciation is modeled in the real world studies.

The fourth research question demands for developing models for optimal scheduling of reserve resources. To deal with this research question an optimization framework is proposed to determine the share of different reserve products that should be purchased from different resources for minimizing reserve procurement cost. This study assumes that reserve cost is a linear function of generation cost which may not be necessarily true.

## **1.5 Outline of the Thesis**

The PhD dissertation contains eight chapters and appendixes. Below are the organization of the thesis and the contents of each chapter.

### **Chapter 1; Introduction**

This chapter gives the background and objective of the thesis. The main contributions and limitations are discussed.

## **Chapter 2; Analysis of Electricity Market in Denmark**

This chapter gives a review on the history of liberalization in power industry and formation of current electricity markets around the world. Nordic electricity market is reviewed in details. Current procedures and mechanisms are elaborated. The roles of different entities in the market are explained and flow of information and cash among these entities are illustrated. The focus is particularly on Danish electricity market which may represent the future of electricity markets for many power systems that plan high penetration levels of wind power. A price survey for Danish Electricity market is then given.

## **Chapter 3; Market Clearing Schemes in Power systems with Significant Wind Penetration**

In this chapter high price volatility and excessive price reduction are introduced as two emerging problems in wind dominant electricity markets. An agent based simulation methodology is employed to investigate the impact of two pricing mechanisms, uniform and pay-as-bid approaches, on these two emerging problems. Electricity market agents in a day-ahead market learn from their previous bidding experience to obtain maximum financial gain using an adaptive learning methodology. A comparative study is then conducted to investigate the bidding behavior of generation companies under two pricing mechanisms. It is shown that these two pricing mechanisms cause market agents to have different bidding behavior. This chapter suggests that this change in market agent behavior modifies the overall price volatility and system average price. The results indicate that a pay-as-bid pricing mechanism can alleviate policy maker's concerns regarding these pricing problems in market with high percentage of wind power penetration. However lack of interest for bidding the marginal price leads to a slight decrease in the defined market efficiency indice. The proposed methodology is implemented on IEEE 24-bus test system.

## **Chapter 4; Economic Operation of Wind-Storage Facilities**

Storage units are important tools for enhancing power system flexibility. They can be charged or discharged in acceptable short periods of time. Storage units can be of different kinds such as hydropower or different types of battery systems. Nature-based storage such as hydropower can be only utilized where it is geographically possible. However battery systems can be utilized

irrespective of geographical constraints. However they are not still economically viable due to huge investment cost especially in utility size level. As a result, to consider installing storage units as a promising investment, the wind farm owner should see other benefits than just mitigating wind power imbalances. In this chapter it is suggested to benefit from storage unit as a regulation service provider (beside its operation for mitigating deviations). This idea is inspired by the fact that storage units have very fast ramping capabilities which is vital to system regulation needs. A formulation framework is presented to investigate optimal operation of a storage unit in different scenarios.

## **Chapter 5; Increasing Demand Responsiveness**

One of the key sources of flexibility is demand response concept. For power systems with significant wind power penetration, it is very important to have responsive loads to deal with wind power variability. Many field studies show that demand responsiveness is not as high as it should be for tracking wind power variations. The key argument is that the price difference between peak and off-peak hours is not big enough to encourage load shifting.

The key idea of this chapter is to improve the demand side activeness by optimally increasing the financial incentives for consumers to participate more efficiently in so-called Demand Response (DR) programs. The proposed scheme is a set of algorithms that optimally converts the original price set to a new set by which DR is systematically encouraged. However several considerations should be taken into account before any sort of price modification can take place. Real data from Danish power system is used to verify the functionality of the proposed model. The results indicate that optimal pricing can increase price responsiveness and successfully shift the load from peak to off-peak hours. An EV-Based test case is studied for validation of proposed methodology.

## **Chapter 6; Reserve scheduling considering cross-border interconnections**

This chapter addresses optimal reserve scheduling considering cross-border interconnections. A Danish case study will be presented. An optimization framework is proposed to minimize the cost of reserve procurement. The framework decouples the share of upward and downward primary, secondary, and tertiary reserve services within DK1 (western Danish power system) and

neighboring cross border resources (Norway and Germany). Results indicate the economic benefit of reserve provision provided by cross border interconnections.

### **Chapter 7; Reserve scheduling considering environmental impact of reserve providers**

In this chapter a mathematical framework is proposed for successive energy scheduling in an electricity market with exogenous reserve regulations. The research work considers that different reserve market participating technologies have their emission expenses. For large scale wind integrated power system with displaced conventional generation, wind turbines are also assumed to participate in providing reserve service. Further, Electric Vehicles (EVs) participation in reserve service market is taken into account to demonstrate that EV's environmental impact varies with the variation in penetration level of renewable energy. It is shown that consideration of environmental impact of reserve providing resources can modify the reserve scheduling outcome.

### **Chapter 8; Conclusions and Future Work**

This chapter presents the summary and main findings of the thesis. The topics for future work are discussed in the end.

### **List of Publications**

The list of scientific articles and reports during the course of this PhD project come in this section.

## References

- [1] Denmark's Energy Strategy 2050 - from coal, oil and gas to green energy, the Danish Government, February 2011.
- [2] Danish power infrastructure in 1985 and 2009, Danish Energy Agency, Available online at: <http://www.ens.dk/en/info/facts-figures/energy-info-maps/download-premade-maps>
- [3] Variability of wind power and other renewables; management options and strategies, International Energy Agency (IEA), June 2005, Available online at: [http://www.uwig.org/iea\\_report\\_on\\_variability.pdf](http://www.uwig.org/iea_report_on_variability.pdf)
- [4] Y.C. Zhang, V. Gevorgian, and E. Ela, Role of Wind Power in Primary Frequency Response of an Interconnection, National Renewable Energy Laboratory, Available online at: <http://www.nrel.gov/docs/fy13osti/58995.pdf>

## Chapter 2

### Analysis of Electricity Market in Denmark

#### 2.1 Power System Restructuring

The process of privatization in power industry is called power system restructuring. This process has challenged many technical and economic concepts in generation, transmission, and distribution of electric power in the last two decades [1].

In the past the government owned the power systems and generation, transmission, and distribution were done by state owned companies. In fact it was governments' duty to construct the electricity generation and transmission infrastructures and to operate and maintain them in order to deliver reliable electric power to the consumers [2]. The electric energy was also generally subsidized because electricity was perceived as a public service. The earliest introduction of power system restructuring took place in Latin America and United Kingdom in early eighties and 1990 respectively [3]. In the liberalized electricity markets, generation units are owned by private companies and government only has the transmission grid and supervises over the economic and reliable operation of the power system. The main arguments for initiating electricity markets are the following:

- To improve economic efficiency by introducing competition in power industry.
- The need for more financial transparency to find out the real price of electricity.
- Attracting private investors for creating new generation capacities in response to ever-increasing electric demand.
- Political issues and oil crisis in 1979.
- Increased public expectations for having better services.
- Environmental concerns and the need for more efficient technologies.
- The success in liberalization in other industries such as transportation industry.
- The improvement in information technology which made the transfer of huge data possible.
- Transmission system maturity which made completion possible.

## 2.2 Nordic Power System and Electricity Market

The electricity market in Nordic countries has been initiated in mid-nineties and has undergone major changes [4]. All Nordic countries have now liberalized their electricity markets, opening both electricity trading and electricity production to competition. Like other parts of the world the main reason for power system restructuring is to create better conditions for competition, and to improve better utilization of electricity generation resources as well as to provide gains from improved efficiency in the operation of transmission grids. Power system liberalization process started from Norway in 1990. Sweden and Finland followed Norway in 1994 and 1995 respectively and started transforming their power industry from vertically organized monopolies to liberalized electricity markets. In 1998, Denmark was the last country in Nordic region to start power system liberalization when large electricity customers were given access to the electricity network [5]. Now Nordic countries buy their electricity from one single market operator (Nord Pool). Nord Pool Spot is Europe's leading power market and offers both day-ahead and intraday markets within nine countries [6]. The total turnover of Nord pool spot was 493 TWh in 2013 [7]. In order to get understanding of this figure, Table I is presented to give the power consumption in two consecutive years.

TABLE I. CONSUMPTION IN NORDIC COUNTRIES

	Consumption in 2012 (TWh)	Consumption in 2013 (TWh)
Denmark	33.8	34
Norway	128.2	128.1
Finland	82.9	81.4
Sweden	141.7	137.5

During 2013 the total Nordic electricity consumption was 380.5 TWh (1.6 percent less than in 2012). There are different types of generation technologies in Nordic area. In Norway, hydropower is the dominant generation while Denmark has zero hydropower capacity [8]. Instead Denmark has a high penetration of wind power. Wind power capacity at the end of the 2013 was 4792 MW which at the time made more than 40% of total generation capacity [9]. Moreover in 2013, wind power



share of electricity consumption was 33.2% which indicates that almost one third of the electric energy which was consumed in this year came from wind power. This figure was 30.1% in the year before. In 2013, for the first time wind turbines in Denmark generated what corresponded to more than 50% of the Danes' electricity consumption in one month. Approximately 54.8% of the total consumption in December 2013 was provided by wind power. Table below shows the key figures for wind power in Denmark in two consecutive years.

TABLE II. WIND POWER FIGURES IN DENMARK

	2012	2013
Wind power generation	10.3 billion kWh	11.1 billion kWh
Consumption (including loss)	34.1 billion kWh	33.5 billion kWh
Wind power share of consumption	30.1%	33.2%
Wind power share of consumption in December	33.5%	54.8%
Wind power capacity	4,166 MW	4,792 MW
Energy content of the wind	Approx. 102% of a standard year	Approx. 93% of a standard year

The last row indicates energy content of the wind power. This is a normalized index which considers the average wind power in the last 30 years in Denmark [10]. According to this definition 2013 was 7% less windy and 2012 was 2% more windy in comparison to the previous 30 years (The average value of the last 30 years is assumed as 100%).

Danish power system consists of two asynchronous power systems; western Danish power system (DK1) and eastern Danish power system (DK2). Most wind power installations are located in the western part both in off-shore and ordinary wind power plants. DK1 and DK2 are treated as two different price zones (bidding area) in Nordic electricity market. Different bidding areas are established when the available transmission capacities are congested. Local TSO (Transmission System Operator) decides in each Nordic country, into which bidding areas the country is divided. As mentioned there are currently two bidding area in Denmark. These areas are five in Norway and

four in Sweden. Finland, Estonia, Lithuania, and Latvia constitute one bidding area each from early 2014.

The different bidding areas indicate transmission constraints, and ensure that price reflects regional market conditions. As bottlenecks always exist in transmission lines, the bidding areas may get different prices which are called area prices. The power flow will always be from the high price to low price area if there is transmission congestion. This will lead to more economic utilization of resources. A critical duty for Nord Pool market is to ensure that market members are treated equally on any bottleneck [6]. Nord Pool calculates the price for each bidding area for each hour in the following day. There are three different markets in the general framework of Nordpoolspot namely;

**Spot Market (Elspot):** It is a market where power contracts of a minimum of one-hour is traded for next day delivery [11]. Consumers and Producers submit their offers and bids to the market and supply and demand curves are constructed. The point of intersection of two mentioned curves determines the Market Clearing Price (MCP).

**Balancing Market (Elbas):** The time span between clearing day-ahead market and actual time of delivery can be lengthy (up to 36 hours). Due to the high level of uncertainties in this time span, participants need market access in the intervening hours to minimize their imbalances for day-ahead market bids.

**Regulating Market:** The main objective of the regulating market is to serve as a tool for Transmission System Operator (TSO) for adjusting generation-load balance. There are two kinds of bids in the regulating market; up-regulating (call for generation increase or load decrease) and down-regulating (call for generation decrease or load increase).

The price which end-user pays for electricity is not exactly the same with either of the mentioned market prices and varies from one country to another based on different tax systems and social welfare approaches (the end-user price is elaborated in section 2.3.4).

### 2.3 Data Survey in Danish Electricity Market

In this section a data survey in Danish electricity market is presented. The hourly day-ahead (spot) price, up-down regulating price, wind power generation, consumption, and interconnections flows can be found in Energinet.dk which is the TSO in Denmark. The focus of the study is in Western

Danish power system (DK1) which has significant wind power penetration and can be mentioned as a wind dominant power system.

### 2.3.1 Day-Ahead Market Price

Fig. 2.1 shows the spot price in two bidding areas in Denmark since the formation of the markets in 2001. DK1 and DK2 represent western and eastern Danish power systems respectively. In this figure the average of hourly price for each year is considered. It can be seen that in the last decade, in most years the average day-ahead market price has been slightly lower in DK1 in comparison to DK2. This is probably due to high wind penetration in DK1. Fig 2.2 shows the hourly price of day-ahead market from 2001 to 2014. The size of the data is quite large. It should be noticed from this figure that, although rare, but negative prices exist in day-ahead market. It can also be observed that negative prices occur more frequently in recent years that the wind power penetration has increased. This can be interpreted as the result of having more variable and unpredictable wind power in the generation portfolio.

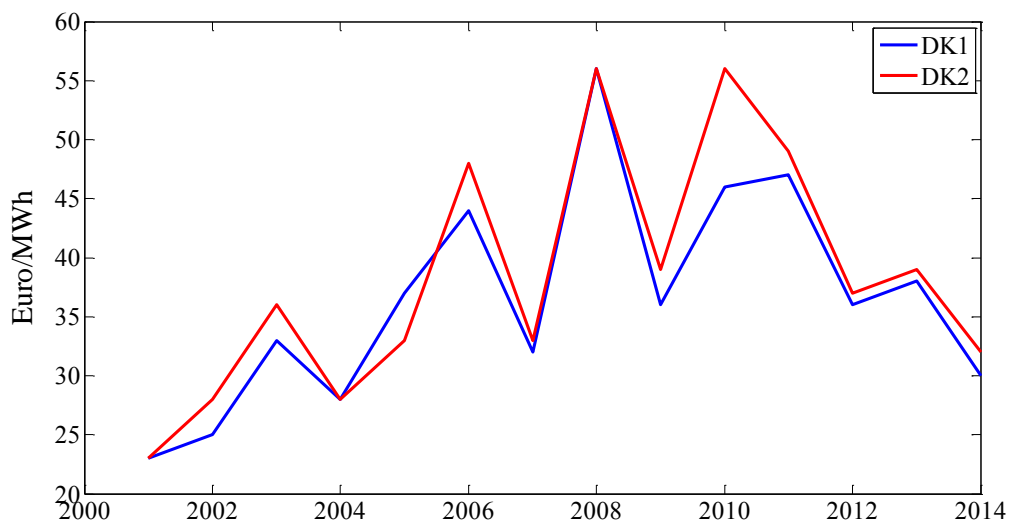

Fig. 2.1. The mean value of day-ahead market price

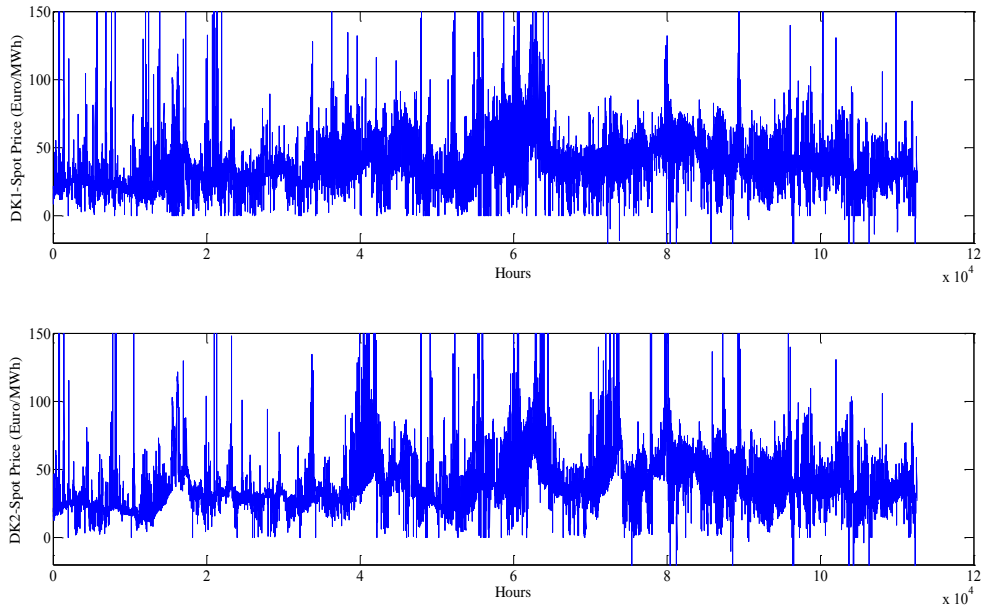

Fig. 2.2. Hourly day-ahead market price in DK1 & DK2

To gain a more clear understanding about the price spikes and negative prices, it is beneficial to consider the price duration curve. Fig. 2.3 captures 14 years of price data in DK1. To have a better illustration, 50 hours with highest prices and lowest prices are omitted in this curve. Similar to Fig. 2.1, this figure shows the slightly lower prices in DK1. Maximum, minimum, average and median of price can be also retrieved and can be potentially used for system planning purposes.

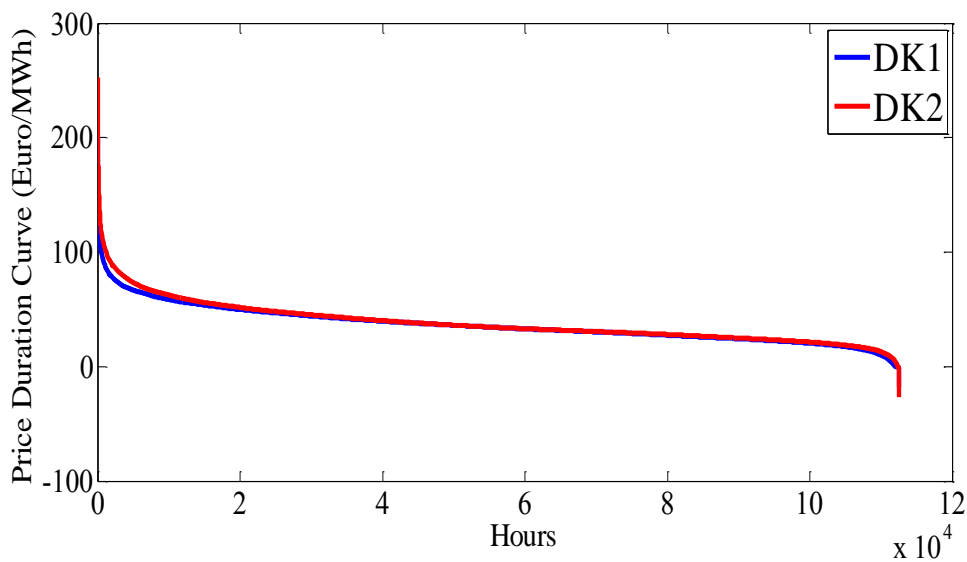

Fig. 2.3. Price duration curves for DK1 and DK2

### 2.3.2 Wind Power Production

In Fig 2.4 the hourly wind power from 2001 to 2014 in DK1 (Western Danish power system) is given. The red line shows the installed wind power capacity at the end of each year. The installed wind power capacity in DK1 has increased from approximately 2500 MW to about 5000 MW during 14 years. The figure also shows that the average power generated by wind power has been steadily increasing.

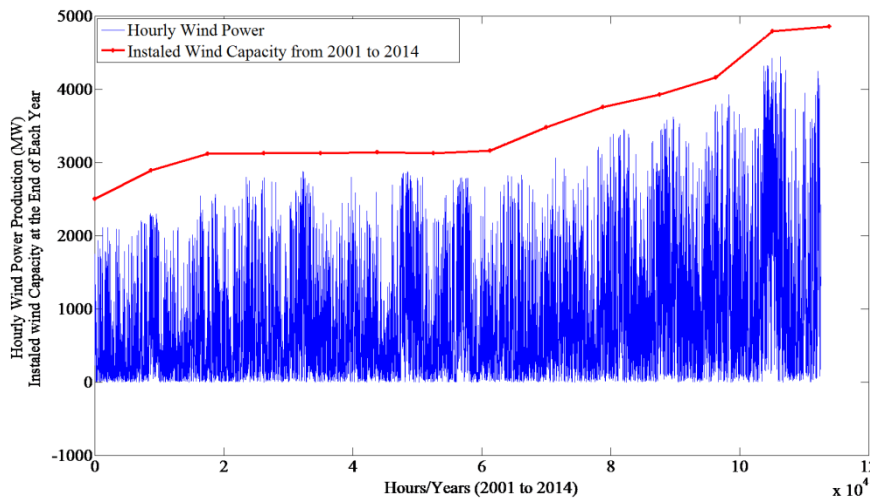

Fig. 2.4. Hourly wind power and installed wind capacity in DK1

Table III shows the generated electricity produced by wind power at the same period of time. It can be seen in this table that the wind electricity has become more than doubled from 2001 to 2014.

TABLE. III WIND POWER PRODUCTION IN DENMARK

Year	2001	2002	2003	2004	2005	2006	2007
Generated electricity (TWh)	4.31	4.86	5.56	6.58	6.61	6.11	7.14
Year	2008	2009	2010	2011	2012	2013	2014
Generated electricity (TWh)	6.98	6.72	7.81	9.77	10.27	11.12	9.30

Wind power production has also increased steadily during the years. Fig 2.5 shows the hourly wind power in DK2. It can be observed that the maximum wind power produced in DK2 is around 900 MW which is much less than this amount in DK1 (around 4000 MW). Fig 2. 6 shows the wind power duration curve for the mentioned period of time. The sharp corners of the two curves in the

right hand side of the plot, show that there have been only few hours in which the wind power production is close to the installed wind capacity (both in DK1 and DK2).

In addition, it is obviously observed that *operation ratio* of the wind power is quite low. For instance for the years in question, wind power capacity starts from 2500 MW to 4800 MW. However, produced wind power is less than 500 MW in more than half of the mentioned time. This fact that the usable power is a small share of the capacity is a negative feature of the wind power.

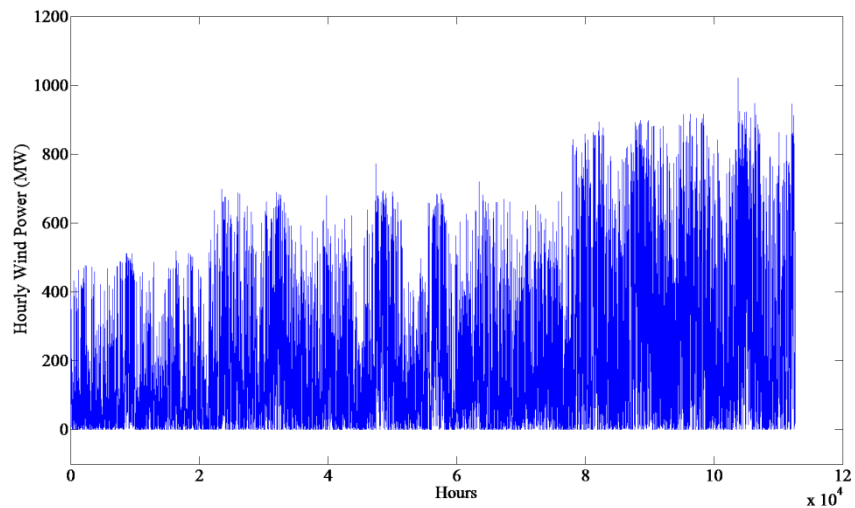

Fig. 2.5. Hourly wind power in DK2

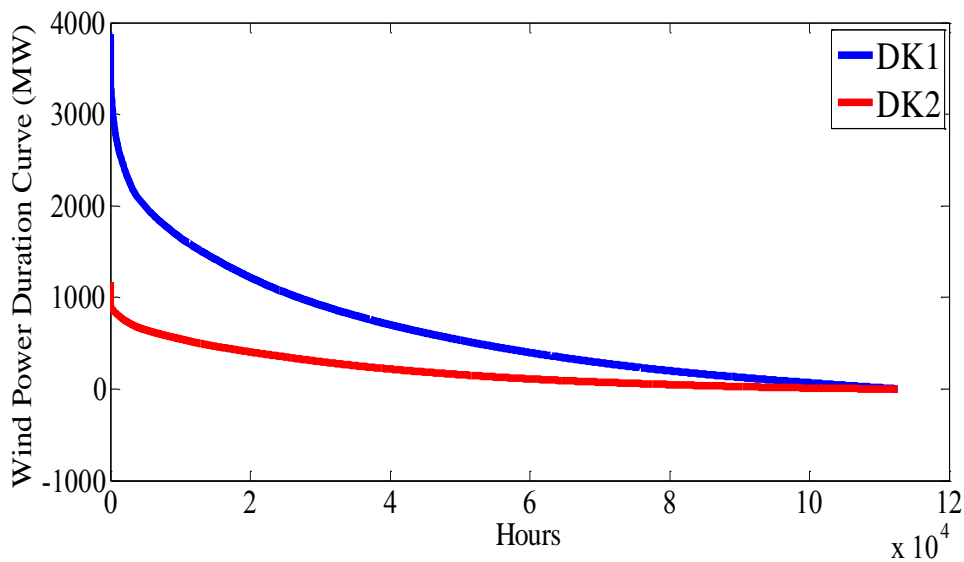

Fig. 2.6. Wind power duration curves

Fig 2.7 shows wind power in DK2 versus wind power in DK1 for the hourly data for 14 years. It can be seen from this figure that wind power in two areas are highly dependent. In addition, the correlation concept can be used for understanding the dependence of wind power production in the two areas. We have used the `corrcoef(X)` function in MATLAB. The correlation between two sets of data is 0.83596 which show the high relation of wind power production in two areas. This indicates that when there is high wind power in Western Denmark, most probably there will also be high wind power in Eastern Denmark and same for scenarios with low wind power production. In high wind power penetration, this high correlation can jeopardize network security.

This fact emphasizes on the importance of having more flexibility in power systems with significant wind penetration. This is particularly true about countries which are small by area (and probably flat such as Denmark) in which there are few geographical diversity. In such power systems there is a critical need for enhancing the flexibility. The sources of flexibility can be having interconnections with neighboring grids, using utility size storage units, utilization of demand side response, optimal time-based utilization of electric vehicles, increasing the ramp rates of the generation units and defining new reserve products in face of wind power uncertainty. Having price versus time and wind power versus time data, it is possible to omit the time and plot price versus wind power. Fig 2.8 shows the day-ahead market price versus wind power from the beginning of 2001 to the end of 2014. It is observed that there have been situations that day-ahead price has been as high as 150 Euros.

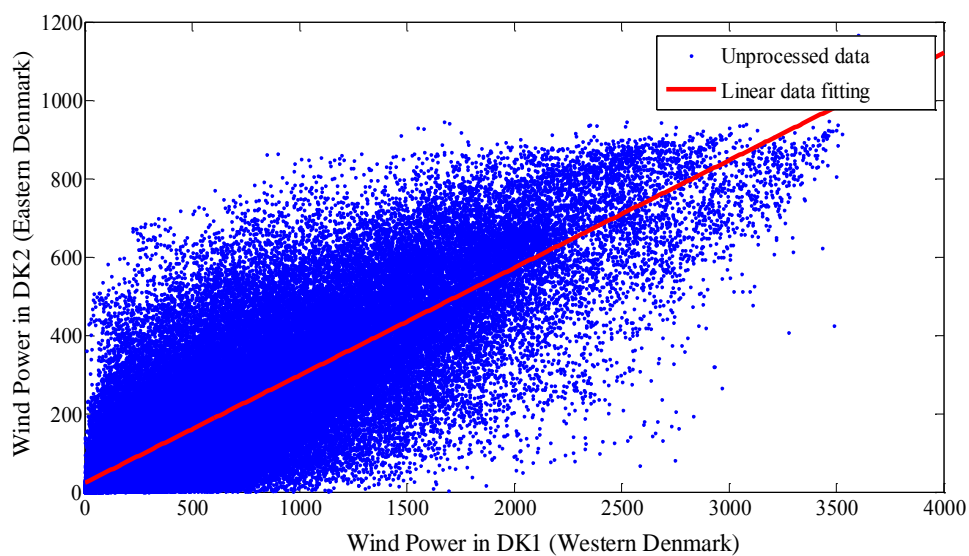

Fig. 2.7. Comparing wind power production in East and West Denmark

Negative prices are also observed less frequently which may be as low as minus 50 Euros. These are the rare situation that market operator pays to consumers to increase their loads in order to maintain power system security level in the accepted range. Data fitting shows that price decreases as wind power is zero marginal cost.

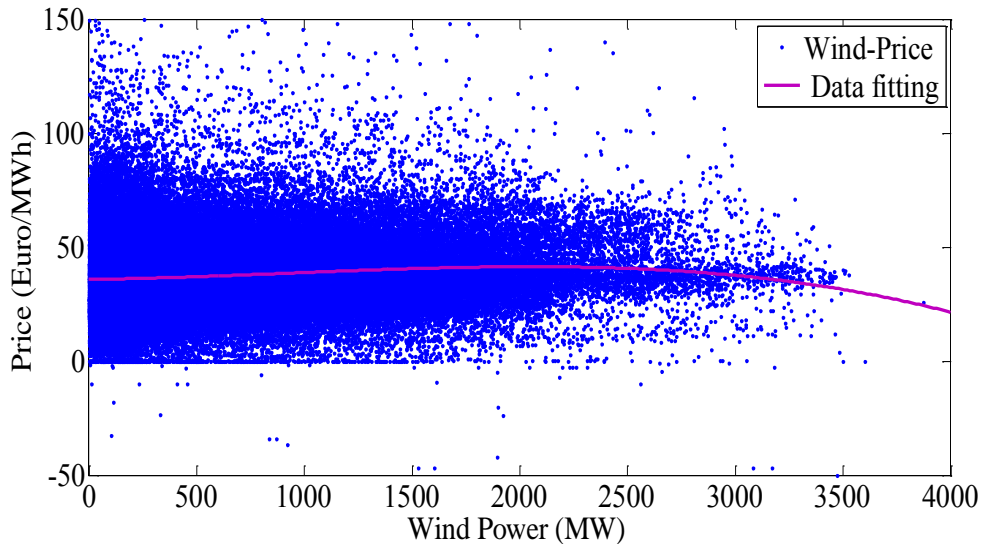

Fig. 2.8. Relationship between price and wind power in DK1

### 2.3.3 Interconnections with Neighboring Networks

Western Danish power system has considerable number of connections with its neighboring grids. These are interconnections with Eastern Danish power system (DK2), Norway, Sweden and Germany. Fig 2.9 shows the Northern Europe transmission network. These interconnections are both HVAC and HVDC types. Having these interconnections are necessary to handle the uncertainty due to high wind power penetration. Fig 2.10 shows the hourly power received and sent to/from DK1 in 2013. Positive sign shows that DK1 receives power (import) and negativity means that DK1 sends out power (export). It can be seen in the second subplot, that in most of the hours in 2013, DK1 sends power to DK2 (the curve is mostly negative) which is the normal situation as large share wind farms are located in DK1. The capacity of interconnections, mutual contracts between areas and grid conditions determine the flow and amount on each interconnection. Fig 2.11 shows the capacity of interconnections between north-European countries and areas. The Net Physical Exchange (NPE) with DK1 is defined as the sum of exchanges on the four interconnections. Fig 2.12 shows how NPE varies with wind power in DK1 in 2013. When wind



power is high, NPE is negative which means that in windy weather conditions DK1 exports power. On the contrary, in low wind production scenarios, DK1 imports energy. The figure explains that in the period of study, the maximum value for import is around 1500 MW while the maximum value for export is 2500 MW.

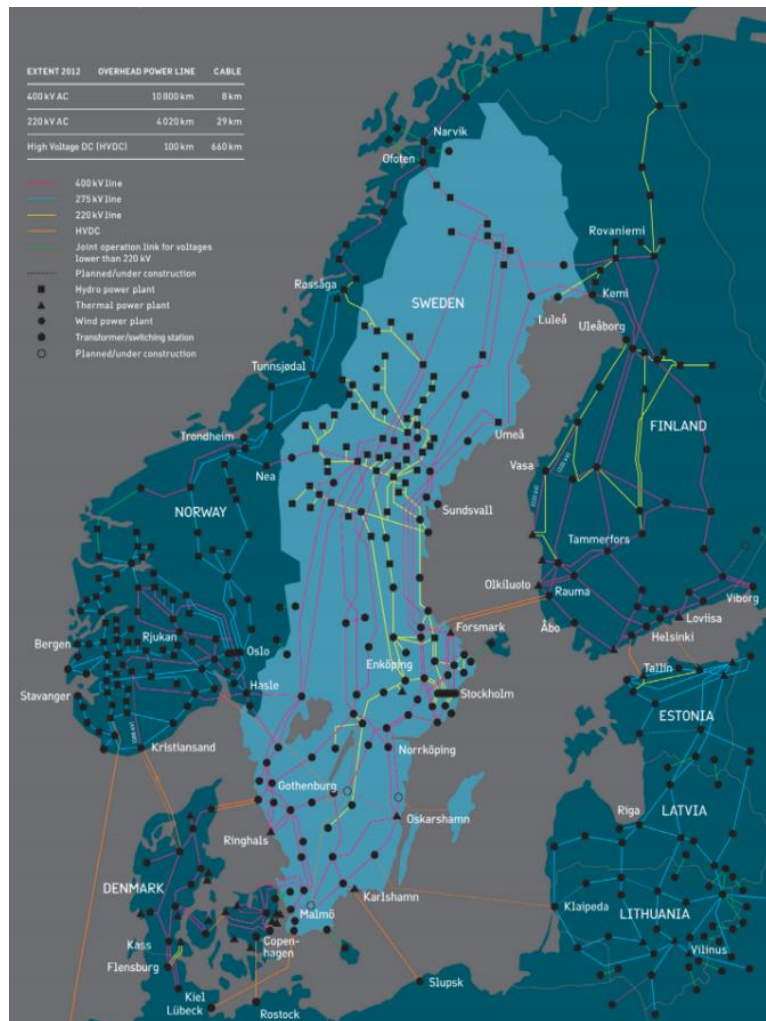

Fig. 2.9. Transmission Network in Northern Europe (Source: Svenska Kraftnät [12] )

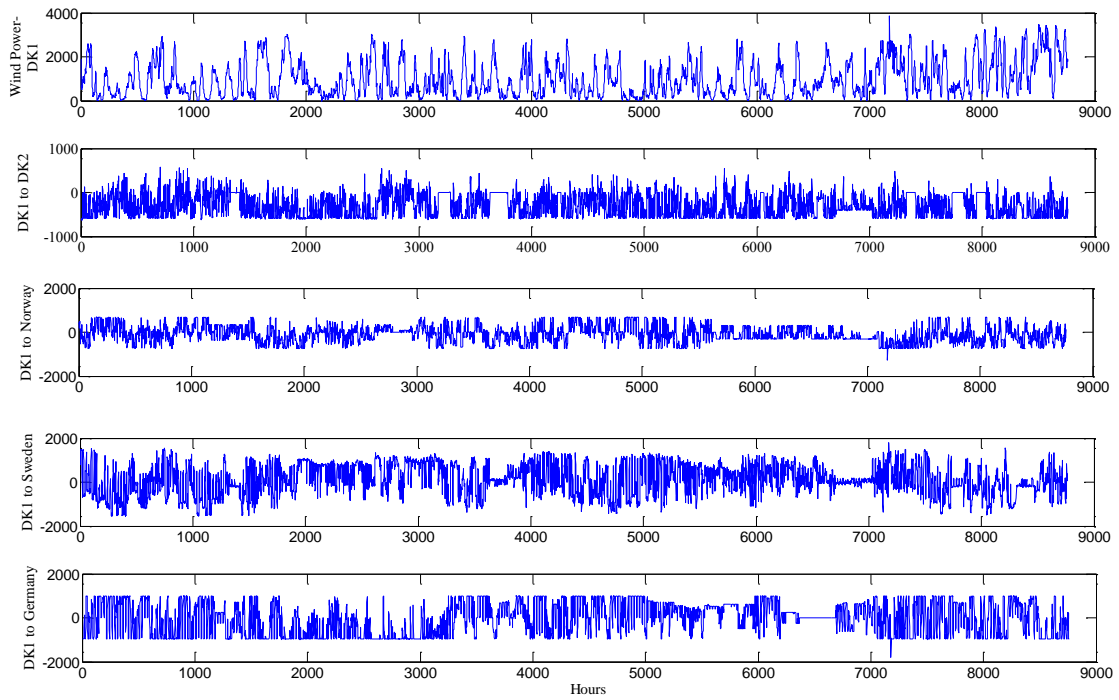

Fig. 2.10. Hourly flow on DK1-interconnections in 2013

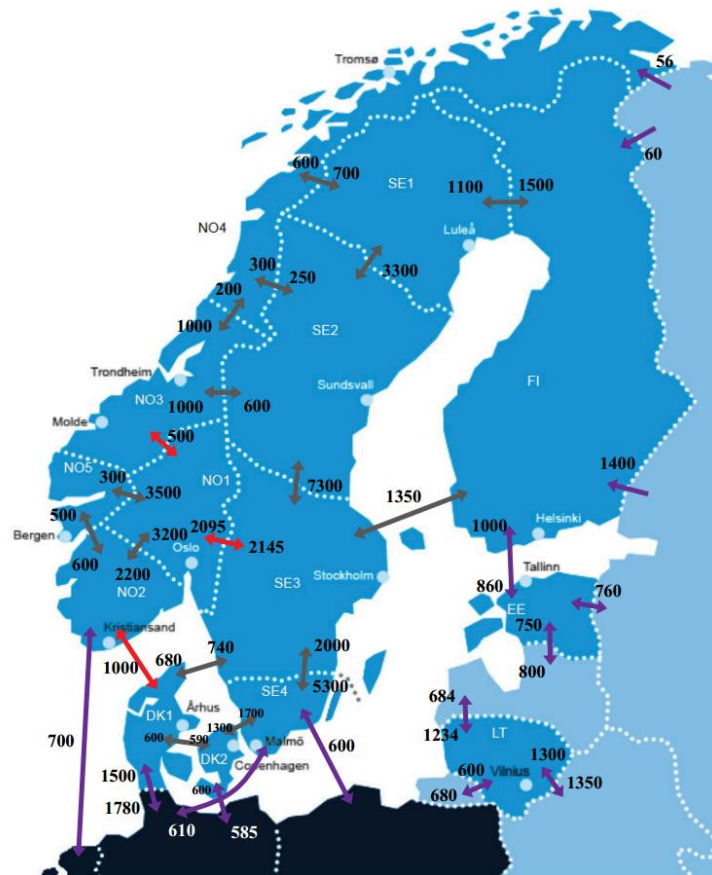

Fig. 2.11. Capacity of interconnections in Northern Europe [7]

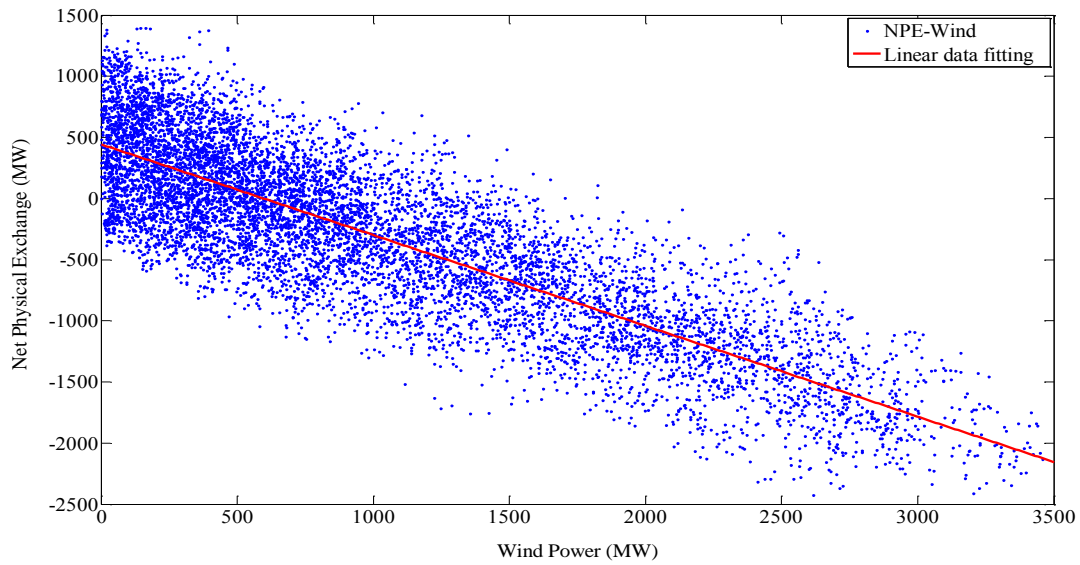

Fig. 2.12. Net physical exchange as a function of wind power

Another interesting behavior about NPE can be observed in Fig 2.13. This figure shows how the day-ahead market prices vary with NPE in 2013. Negative prices are experienced in negative NPE conditions (scenarios that DK1 exports energy), but not in positive NPE conditions. In other words negative price were never observed in the conditions that DK1 is importing energy. In these conditions there is deficit for power in DK1 and market-based logic of the system implies that no negative-price should exist in these conditions.

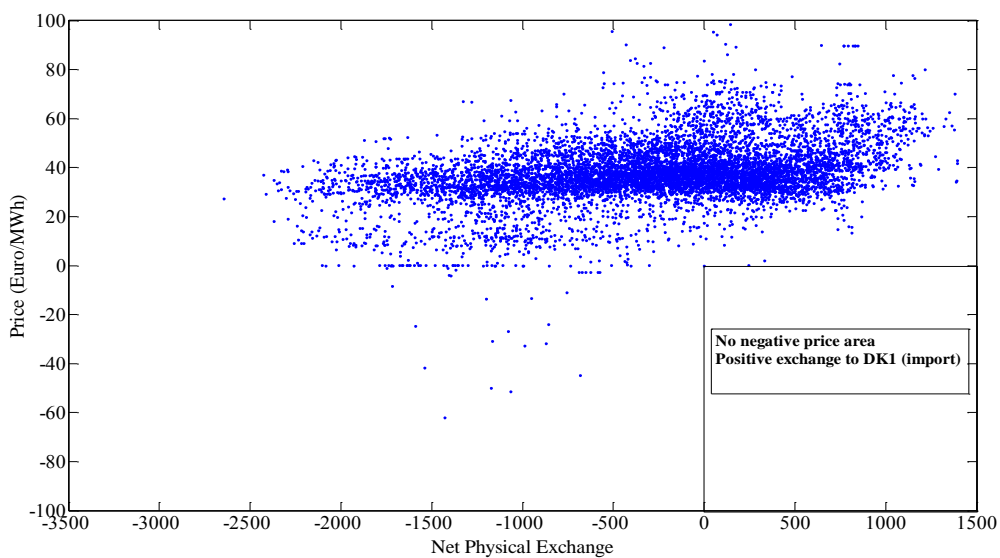

Fig. 2.13. Elaborating no-negative price area

### 2.3.4 Consumption

Fig 2.14 shows the hourly consumption in DK1 and DK2. This figure depicts that the consumption has remained almost constant since the last 14 years. It can be seen that the consumption is low in summers and high in winters. This is due to high lighting and heating consumption in winters. It should be mentioned that the daylight is low in winter and high in summer in Denmark.

Figure 2.15 shows the load duration curve in DK1 and DK2. It can be seen that the peak load has been more than 3500 MW in DK1 and 2500 MW in DK2. The base load can also be retrieved from the introduced load duration curve.

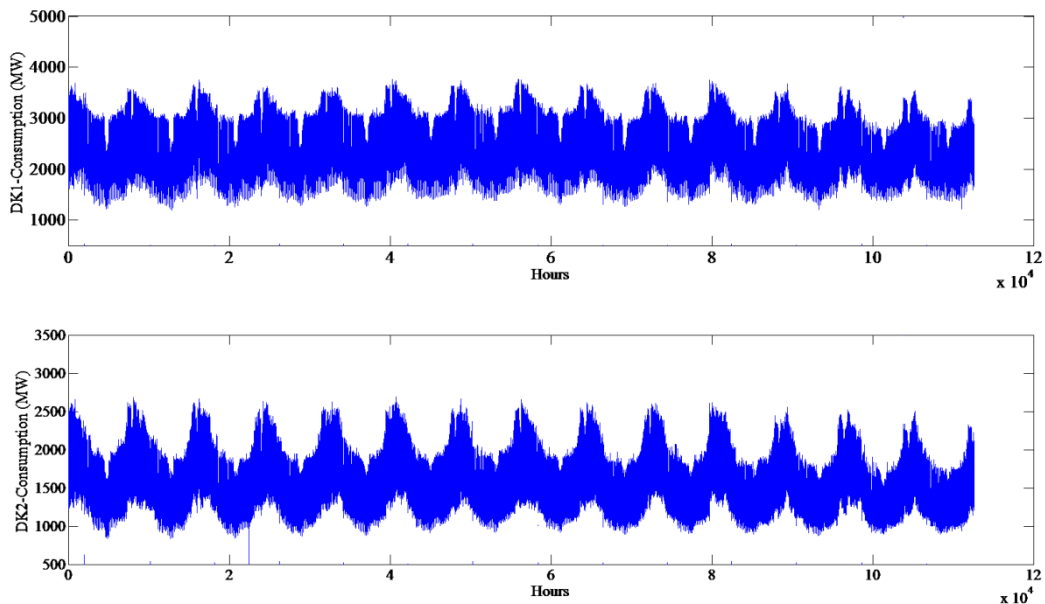

Fig. 2.14. Consumption in DK1 and DK2

Fig 2.16 shows day-ahead market price versus consumption in DK1. The minimum consumption in 14 years period is around 1300 MW and the peak load is around 3600 MW. As expected higher prices occur in higher consumption levels. It should also be noticed that price difference in low and high consumption conditions is relatively low (low steep of the linear data fitting). The hourly data for 14 years is used in Fig 2.17 to plot wind power versus consumption. This figure corroborates that, high wind power scenarios mostly occur in low loading levels in DK1. On the contrary, in high loading levels there is less wind power production. The reason is higher wind speed and lower consumption in the night time. This figure implicitly explains the importance of loads such as

electric vehicles which can harvest abundant wind power in the night time and can offer ancillary services in the day time in less windy scenarios (ancillary services such as upward regulating power).

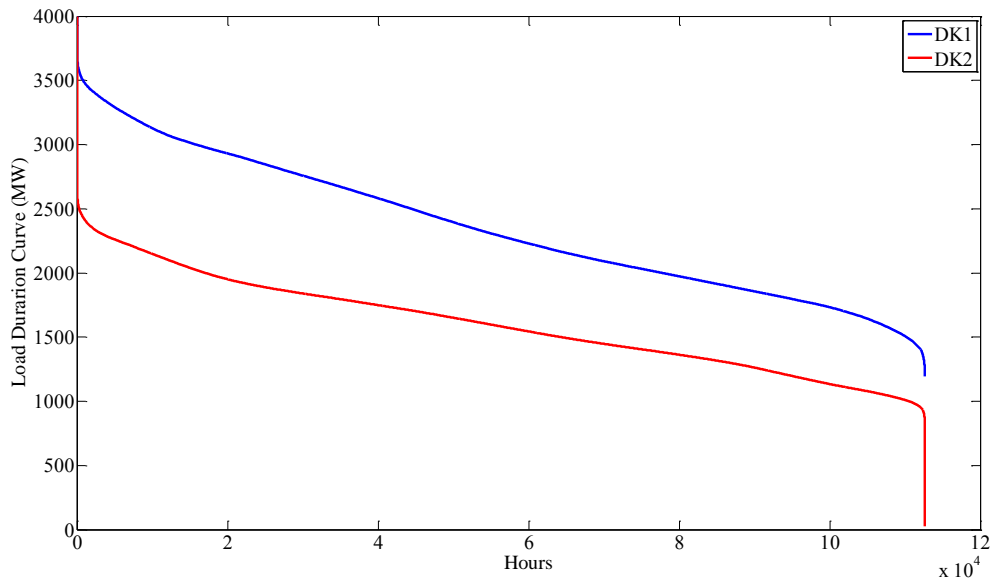

Fig. 2.15. Load duration curves in DK1 and DK2

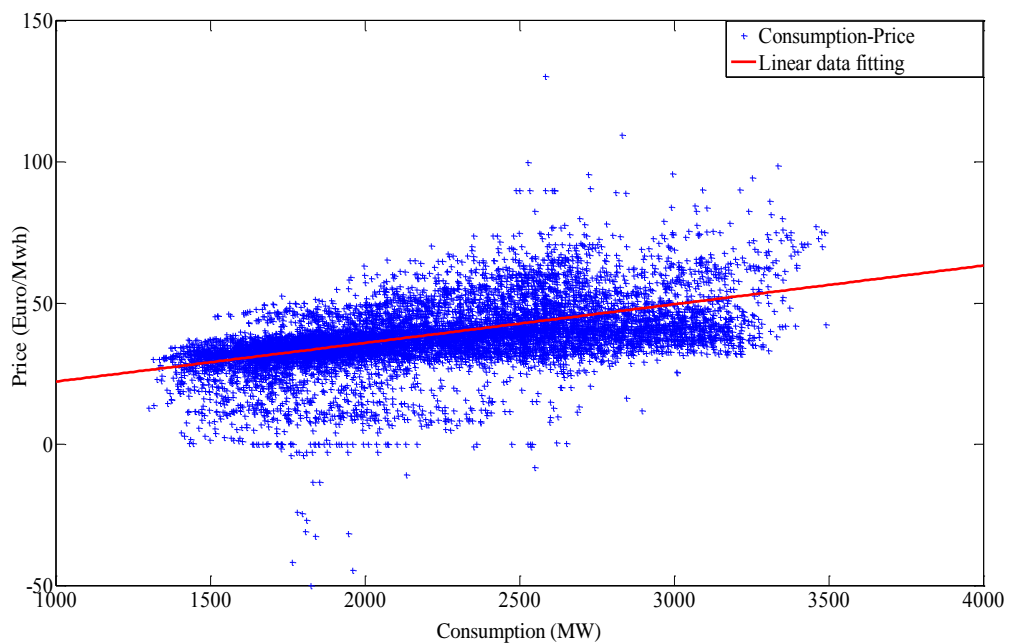

Fig. 2.16. The relationship between price and consumption

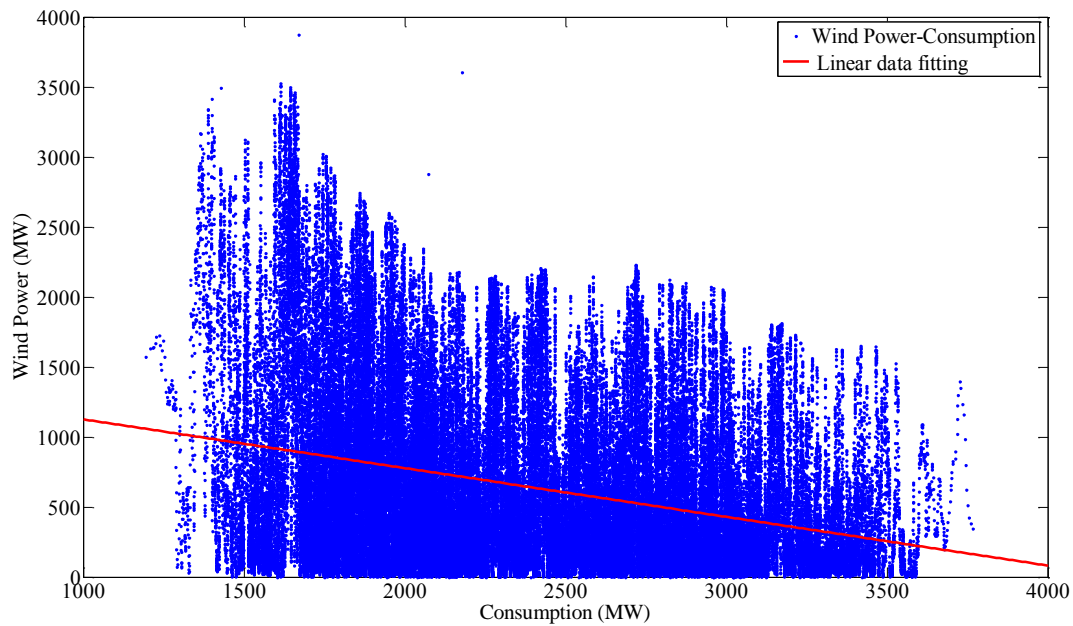

Fig. 2.17. Wind-Consumption data for DK1

### 2.3.5 Price components for End user

In the previous section, the focus was on day-ahead market. However the price that the end-user pays for every kilo-watt hour of energy is different from the day-ahead market price. Fig 2.18 illustrates the components of price for residential sector in Denmark. As it is shown in this figure the electricity cost is only 16% of the price that should be paid for every kilo-watt hour [11].

The other 84% goes for grid payments, taxes, and subscription. Out of 16% which addresses electricity cost, 14% covers the wholesale market and only 2% are dedicated to energy retail companies which show that these companies have modest revenues. Similarly Fig 2.19 and Fig 2.20 show price components for every kilowatt hour of electricity in Norway and Sweden respectively. Comparing three figures show that Denmark has the lowest share of electricity price in the portfolio (16% against 40% and 34%). Fig 2.21 shows the annual electricity expenses for an average family with 4 people in Denmark from 2007 to 2012. It can be realized that the average Danish family pays around 1300 Euros for the electricity bills which between 3-4 percent of the total annual family income. This low financial incentive can explain the reluctance of electricity consumers to participate in demand side management programs. Table IV shows the percentage of the consumers that changed their local electricity provider in the Scandinavian countries. This is called switch rate

which is one of the criteria which shows the degree of competitiveness in a given electricity market. It can be seen that Denmark has the lowest switch rate among Scandinavian countries.

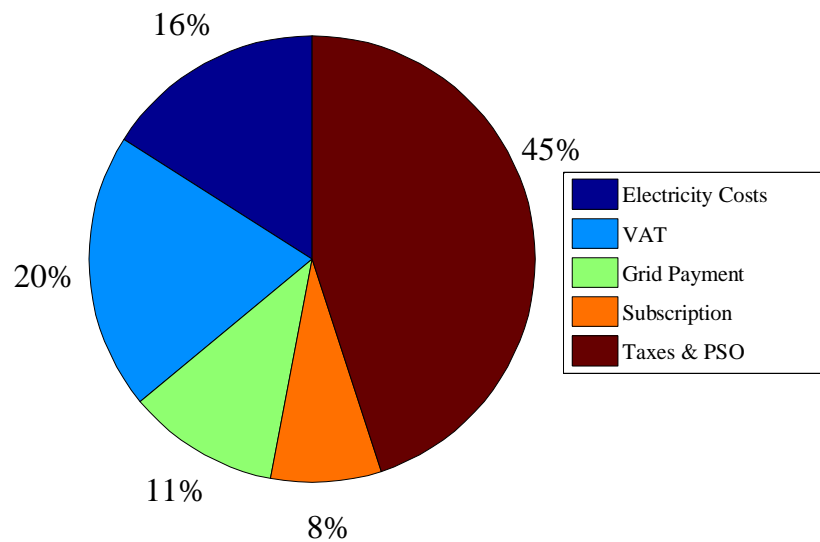

Fig. 2.18. Electricity price components in Denmark

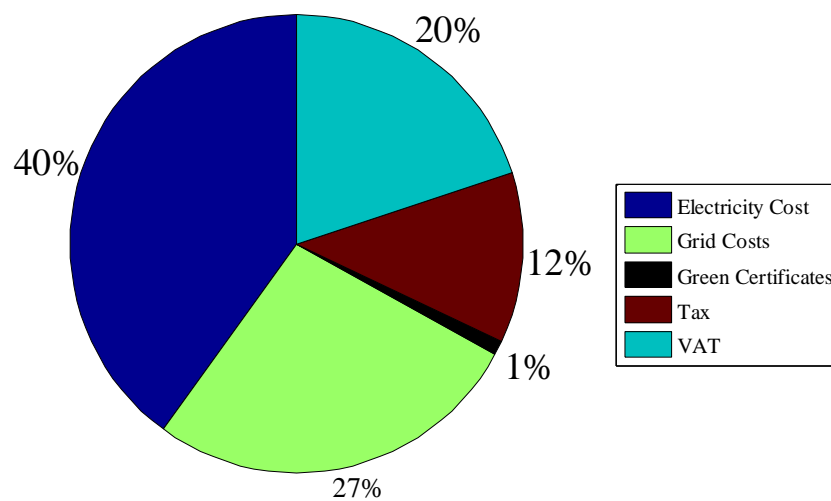

Fig. 2.19. Electricity price components in Norway

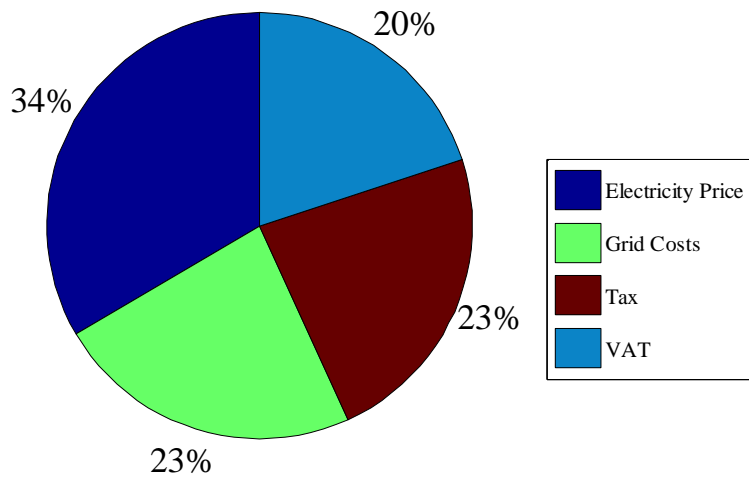

Fig. 2.20. Electricity price components in Sweden

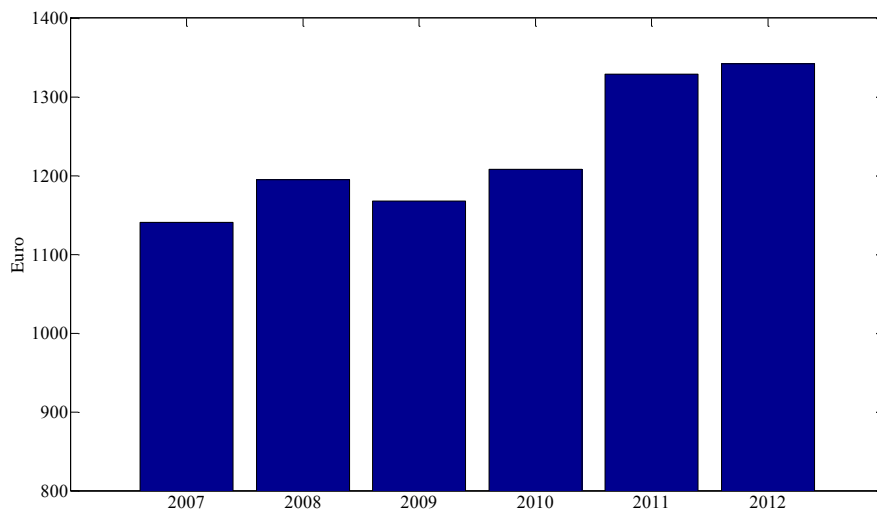

Fig. 2.21. Annual electricity expense for average family in Denmark [11]

TABLE IV. SWITCH RATE (CHANGING THE LOCAL POWER PROVIDER COMPANY)

	2011	2012	2013
Denmark	3.5%	6.7%	1.7%
Norway	11.3%	13%	15%
Sweden	11.2%	9.4%	10.7%
Finland	7.6%	7.7%	10.1%



## 2. 4 Summary

This chapter gives a general overview about the Danish power system and also electricity market in Denmark. The focus is on historical development of wind power in Denmark as the country which has the highest penetration of wind power in the world. The data survey benefits from hourly data in the last 14 years since power industry liberalization in Denmark.

## References

- [1] Harris, Chris. Electricity markets: pricing, structures and economics. Vol. 565. John Wiley & Sons, 2011 (Book).
- [2] Ilic, Marija D., Francisco Galiana, and Lester Fink, eds. Power systems restructuring: engineering and economics. Vol. 448. Springer, 1998, (Book).
- [3] Schweppe, Fred C., Richard D. Tabors, M. C. Caraminis, and Roger E. Bohn. "Spot pricing of electricity",1988, (Book).
- [4] Wangensteen, Ivar. "Power system economics: the Nordic electricity market", 2012, (Book).
- [5] Available online: <http://www.nordicenergyregulators.org/>
- [6] Available online: <http://www.nordpoolspot.com/>
- [7] Nordic Market Report 2014 Development in the Nordic Electricity Market, Technical Report, Available online at: <http://www.nordicenergyregulators.org/wp-content/uploads/2014/06/Nordic-Market-Report-2014.pdf>.
- [8] [http://en.wikipedia.org/wiki/Electricity\\_sector\\_in\\_Norway](http://en.wikipedia.org/wiki/Electricity_sector_in_Norway).
- [9] Denmark's system operator home page. Available at <http://www.energinet.dk/>
- [10] Danish Wind energy index version 13 update. Available at <http://www.vindstat.dk/>
- [11] Danish Energy Regulatory Authority (Energitilsynet), Results and Challenges 2012, Technical Report, Available at: [http://energitilsynet.dk/fileadmin/Filer/publikationer/R\\_U\\_2012\\_UK\\_pdfa.pdf](http://energitilsynet.dk/fileadmin/Filer/publikationer/R_U_2012_UK_pdfa.pdf)
- [12] Svenska Kraftnät, Swedish Transmission System Operator, 2013 annual report.

## Chapter 3

### Market Clearing Schemes in Power systems with Significant Wind Penetration

#### 3.1 Uniform and pay-as-bid schemes

In a deregulated electricity markets, generation units and loads submit their bids and offers to the market place where market operator builds demand and supply curves. Supply versus price curve is an ascending function considering the fact that as electricity price goes higher there will be more generation companies that are willing to sell their power to the market place. On the contrary, demand versus price is a descending curve as electricity price goes higher there will be naturally less consumers willing to pay for that. The building of supply and demand is normally done on a daily basis in a so-called day-ahead market. The point of intersection of demand and supply curves is called Market Clearing Price (MCP). The way the generation companies are paid can be in two ways; uniform (marginal) and pay-as-bid (discriminatory). In uniform scheme generation units will be paid the MCP, while in pay-as-bid scheme they will be paid what they have bid to the market. In most electricity markets around the world uniform pricing is used, however increasing discussions have been in the power industry about the suitable pricing scheme. Rethinking about the current regulations is particularly important as the generation portfolio of power systems are getting changed as the share of intermittent renewable energy sources grow. High share of renewables increase the price volatility and excessively decreases the average price of electricity which is undesired. Pay-as-bid scheme is famous for reducing price volatility and increasing average price. The conjecture is that a switch from current uniform to pay-as-bid scheme may be a solution to address the mentioned problems caused by high share of renewables. An agent based simulation is conducted in this chapter to investigate the impact of mentioned pricing schemes.

#### 3.2 Impact of wind penetration on Electricity Price

Many papers in literature have discussed how electricity price profile behaves in high penetration of wind power. While many papers have discussed average price in day-ahead, intra-day and regulating markets, fewer discussions are about price volatility. These studies have mainly shown; higher penetration of wind power leads to lower average price (due to low marginal price of wind

power) and higher price volatility (due to uncertain nature of wind power). In [1] the impact of different wind penetration levels on average value and volatility of Locational Marginal Prices (LMP) is discussed. Lower LMP and higher price volatility is concluded in high wind power penetration. The impact of variability of wind power on market prices -based on a single auction model- is investigated in [2]. Two different models of time series predictors are employed to forecast market prices where an asymmetric Mean Absolute Error value (MAE) is the parameter for accuracy evaluation of the proposed models. Additionally, a direct relationship between higher penetration levels of wind power and lower market prices with high volatility is uncovered. In [3], Danish electricity market is studied to analyze the relationship between electricity prices in different penetration levels of wind power using five years statistical data of Danish power system. One of the main findings of [3] is that there is a nonlinear relationship between the spot price and wind power penetration in that system. In low penetration levels, the average spot price decreases slightly as penetration level grows, however, it experiences a high decrease as wind penetration level grows in penetration levels more than 40%. In [4] a detailed analysis is conducted to study to what extent installed wind capacity has influenced day-ahead electricity prices in Netherlands. It is claimed that only 4% of wind penetration caused 5% depression in day-ahead prices in 2008 in Netherlands. More significant values are reported in west and east Denmark, Spain and Germany. Reference [5] considers wind farms as price makers in electricity market and evaluates average price and price spikiness. It is also shown that allowing wind to contribute in the market as spinning reserve is beneficial both for overall system and wind producers as it gives them the opportunity to strengthen their revenue by ancillary services payments.

There have also been numerous studies that compare different pricing mechanisms in electricity markets. While intense contest is discussed in [6]-[10], there is not a consensus on the appropriate pricing mechanism and rational approaches consider each market in its own scope and characteristics. General trend in literature states lower price volatility and moderate price increase under a discriminatory pricing approach. The main contribution of this study is to investigate market behavior under two different pricing mechanisms in markets with very high penetration of wind power.

### **3.3 Price Issues in Electricity Markets with high Wind Penetration**

High intermittency in the nature of wind power emphasizes conceptual revising in the mechanisms of electricity markets with high wind power penetration levels [11]. In this section overmuch price reduction and high price volatility are introduced as two adverse consequences in future wind dominant electricity markets. While high price volatility imposes elevated risk levels for both electricity suppliers and consumers, excessive price reduction of electricity is a disincentive for investment in new generation capacity and might jeopardizes system adequacy in long term.

A comparative study between marginal to discriminatory pricing mechanisms are conducted to this end. This particular direction has been chosen because the discriminatory approach is traditionally known for lowering price volatility while gently increasing average price. To this end an adaptive agent based simulator under two pricing mechanisms is developed. It is shown that pay-as-bid pricing approach can be beneficial in high penetration of wind power because it alleviates high price variations and spikiness and prevents overmuch price reduction in wind dominant electricity at the same time. The bidding behavior of generators is investigated. 5 nodes and 24 nodes IEEE test networks are used to show the validity of the proposed algorithms.

#### **3.3.1 Agent Based Simulation**

Decision making in repeated games where the repercussion of opponents is unknown can benefit from agent based approaches. Agent based modelling has been used in power system applications for last two decades. This is especially the case for studying the generation units' participation behavior in electricity markets. Unlike general trends in agent based simulation approaches in which agents implement learning heuristics, a predictive bidding method for maximizing discount profit is proposed in [12]. A case study is then carried out in which the agent based method considers the cross border capacity constraint between four European countries. In a similar study in [13] electricity trading arrangements in UK in the year 2001 has been modeled using a multiagent evolutionary method. The proposed simulation model has provided strategic bidding insights ahead of actual introduction of the rules.

In [14] demand response from commercial buildings in a market framework is modeled using an agent based simulation technique. The focus is on the consumption behavior of commercial buildings in different levels of demand response. In [15] an agent based approach is used to model

capacity withholding and its impact on market outcomes in a double price cap market structure. In [16] an agent based computational framework with Q- learning capability is used to measure market power of generation unit in electricity market. A fuzzy approach is used to estimate the exercised market power. In the next part an agent based methodology is used to investigate the impact of market clearing scheme on the bidding behavior of generation units. Generation units are modeled as agents that have learning abilities, they submit bid to the market randomly and the probability density function of the bidding process is updated in the way that the units can gain higher revenues.

The agent based modeling which will be mathematically explained in 3.3.3 uses economic dispatch problem internally. For this reason economic dispatch problem is explain in the following section.

### 3.3.2 Economic dispatch

Generation units have different incremental costs mostly due to the differences of their fuel costs and their efficiencies. Economic dispatch minimizes overall production costs by optimally allocating electric demand to generating units that are online. Control centers run optimization algorithms, typically every 5 or 10 minutes, to determine the optimal dispatch for the next hour, and send these economic dispatch signals to generation units. In some operation situations, power (energy) cannot be dispatched from the lowest-cost generating units due to the system's physical limitations, or security constraints associated with maintaining secure operation of power systems under plausible contingencies. Physical restrictions include transmission lines' thermal capacity, delta angle stability constraints, and limitations on generating units (including ramp rates and units' capacity limits). Generation cost functions  $C_i(\cdot)$  are increasing functions of produced power by  $P_{g,i}$ . Economic Dispatch problem can be represented as:

$$\min_{P_i, \delta_i} \sum_{i=1}^n C_i(P_{g,i})$$

Subject to:

$$\sum_i P_{g,i} = \sum_j P_{L,i} \text{ (Load-Generation balance)}$$

$$P_{g,i} \leq P_{g,i}^{max}, P_{g,i} \geq 0 \quad (\text{Generation unit limits})$$

$$P_{g,i} = \sum_{i=1}^n |V_i| |V_j| Y_{ij} \sin(\delta_i - \delta_j), \quad i=1, \dots, n \quad (\text{Power flow constraint})$$

$$P_{ij} = |V_i| |V_j| Y_{ij} \sin(\delta_i - \delta_j) \leq L_{i,j} \quad (\text{Transmission line constraints})$$

$$P_{ij} = |V_i| |V_j| Y_{ij} \sin(\delta_i - \delta_j) \geq -L_{i,j} \quad (\text{Transmission line constraints})$$

Where  $P_{L,i}$  is the load at bus  $i$ ,  $\delta_i$  is the delta angle in each bus  $i$ ,  $P_{ij}$  is the power flow from bus  $i$  to bus  $j$ , and  $Y_{ij}$  is the admittance between bus  $i$  and bus  $j$ . The AC Economic Dispatch is difficult to solve as it is nonlinear, however some simplifications can be made. DC ED is a linearized version of ordinary AC ED in which linear or piecewise linear cost functions are used instead of polynomial cost functions (in this study linear cost functions are used). DC ED provides linear relations between injections and line flows. This is possible by assuming  $\sin(\delta_i - \delta_j) \approx (\delta_i - \delta_j)$  which is valid in most of normal operation condition cases as  $(\delta_i - \delta_j)$  is small. Also voltages can be considered equal to unity (in normal operation conditions;  $|V_i| \approx 1$  per unit. This is special true in transmission networks which R/X ratio is small). Having the mentioned assumptions in mind, DC Economic Dispatch is formulated in power system literature as follows:

$$\min_{P_i, \delta_i} \sum_{i=1}^n C_i(P_{g,i})$$

Subject to:

$$P_{g,i} - P_{D,i} + \sum_j P_{ij} = 0$$

$$P_{ij} = Y_{ij}(\delta_i - \delta_j)$$

$$-L_{ij}^{max} \leq P_{ij} \leq L_{ij}^{max}$$

Having the optimal solution  $(P^*, \delta^*)$ , the marginal price<sup>1</sup> of each generation unit is :  $\frac{\partial}{\partial P_i^*} (C_i(P_{g,i}^*))$ .

The market clearing price is the marginal price of most expensive dispatched generator.

---

<sup>1</sup> The cost of last produced MW for a given unit. The nodal prices are the Lagrange multipliers of the first constraint.

### 3.3.3 Modeling the agent based simulation process

In this section a technique is proposed to simulate the bidding behavior of market participants. The technique is conceptually close to reinforcement. The focus here is on the implementation of learning process. Generation Companies (GenCos) bid randomly according to probability distribution which is uniform in the beginning (first iteration of learning procedure) but evolves as it learns from previous market clearing experiences. The probabilistic behavior of each generator is presented as a Probability Density Function (PDF) by which this GenCo makes its bidding decisions. The  $g$ -th generator at  $i$ -th iteration ( $\hat{\lambda}_{g,i}$ ) randomly bids between its own marginal price ( $\lambda_g^{min}$ ) and the market price cap ( $\lambda^{max}$ ) according to the corresponding probabilities ( $p_{g,i}^m$ ), as shown in Fig. 3.1. Thus, each generator represents its cost by equation (3.1).

$$C_{g,i} = \hat{\lambda}_{g,i} \times P_{g,i} \quad (3.1)$$

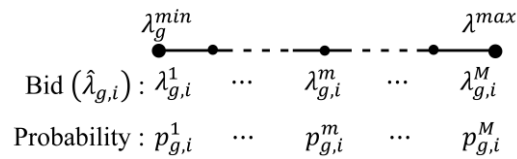

Fig. 3.1. The  $g$ -th generator randomly bids in  $i$ -th iteration according to the probability of each bid value.

For each GenCo, it is supposed that the bidding interval  $[\lambda_g^{min} \dots \lambda^{max}]$  is divided into  $M$  equal segments. In each iteration, one of these segments is randomly selected and the bid is chosen the upper limit of the selected segment, as the GenCo's bid in day-ahead market. For the first iteration, a uniform distribution is assumed for this PDF as specified in (3.2). As it was stated in the previous paragraph the evolving PDF occurs in according to previous market clearing experiences. Note that the sum of probabilities should be equal to unity as given by (3.3).

$$p_{g,1}^m = 1/M \quad (3.2)$$

$$\sum_{m=1}^M p_{g,i}^m = 1 \quad (3.3)$$

As GenCos selected their bids, a day-ahead market is performed to minimize the total cost using a Mixed Integer Linear Programming. The equality constraints are the load-generation balance. The inequality constraints are the active power output of generators ( $P_{g,i}$ ) and transmission lines flow ( $P_t$ ) which are limited to maximum generation capacity ( $P_g^{max}$ ) and maximum transmission capacity ( $P_t^{max}$ ), respectively. The market runs once under discriminatory (DIS) and once under uniform (MP) market clearing approach.

After running the market, the system average price at  $i$ -th iteration ( $\bar{\lambda}_{s,i}$ ) is defined as the mean of the system price ( $\lambda_{s,i}$ ) up to  $i$ -th iteration as in (3.4).

$$\bar{\lambda}_{s,i} = \sum_{t=1}^i \lambda_{s,t} / i \quad (3.4)$$

The generators' revenue in discriminatory and marginal pricing approaches is given by (3.5) and (3.6), respectively.

$$R_{g,i}^{DIS} = (\hat{\lambda}_{g,i} - \lambda_g^{min}) \times P_{g,i} \quad (3.5)$$

$$R_{g,i}^{MP} = (\lambda_{s,i} - \lambda_g^{min}) \times P_{g,i} \quad (3.6)$$

The generators revenue ( $R_{g,i}$ ) is obtained according to the pricing approach that could be ( $R_{g,i}^{MP}$ ) or ( $R_{g,i}^{DIS}$ ). Then, the average revenue is defined as follow:

$$\bar{R}_{g,i} = \sum_{t=1}^i R_{g,t} / i \quad (3.7)$$

Depending on whether the chosen bid ( $\hat{\lambda}_{g,i}$ ) increases or decreases the unit revenue, the probability of bids in related PDF changes in each iteration<sup>2</sup>. In  $i$ -th iteration for  $g$ -th generator, if  $R_{g,i}$  is less than

---

<sup>2</sup> A similar method is used in [17].  $p_{g,i+1}^m$  is bid amount in the next market participation experience.



$\bar{R}_{g,i}$ , the probability of the randomly selected bidding strategy ( $p_{g,i}^m$ ) is decreased with a constant value ( $\alpha$ ) and the probabilities of other bidding strategies are increased with  $\alpha/(M - 1)$ , as given by equation (3.8) and (3.9), respectively :

$$p_{g,i+1}^m = p_{g,i}^m - \alpha \quad (3.8)$$

$$p_{g,i+1}^{\hat{m}} = p_{g,i}^{\hat{m}} + \alpha/(M - 1) , \quad \hat{m} = \{1, \dots, M\} - \{m\} \quad (3.9)$$

Otherwise, if  $R_{g,i}$  is not less than  $\bar{R}_{g,i}$ , the probabilities are obtained using (3.10) and (3.11):

$$p_{g,i}^m := p_{g,i}^m + \alpha \quad (3.10)$$

$$p_{g,i+1}^{\hat{m}} = p_{g,i}^{\hat{m}} - \alpha/(M - 1) , \quad \hat{m} = \{1, \dots, M\} - \{m\} \quad (3.11)$$

It must be ensured that the obtained probabilities of a generator are between 0 and 1 ( $0 \leq p_{g,i}^m \leq 1$ ) and the sum of the probabilities is equal to unity, as given by (3.3).

The coefficient of variance ( $c_v$ ) of the system average price is used as the stopping criteria.

$$c_v = std(\bar{\lambda}_{s,i})/mean(\bar{\lambda}_{s,i})^3 \quad (3.12)$$

Where  $std(.)$  and  $mean(.)$  are standard deviation and mean of the system average price, respectively. Simulation is performed for several loading levels given by different loading factors  $l = l_{min}, \dots, l_{max}$ . The loading factor is defined as the rate between the load level and the total

---

<sup>3</sup> Doing try and see experiments on the computer program, it is understood that using this formula as stopping criteria prevents being trapped in the local dynamics (in comparison to more simple criteria such as  $c_v = std(\lambda_{s,i})$  ). The reason is that, it captures the price behavior from the first market clearing experience and avoids relying only on the last iterations. This is a more robust stopping criterion in comparison to other measures for instance  $std(\lambda_{s,i})$ . Dividing by average system price, make the deviations smoother.

generator capacity. A given load curve explains the different loading factors and their probabilities( $q^{(l)}$ ). For the sake of simplicity, presented formulation doesn't show the index of the loading factor.

Here, the price volatility ( $\Delta$ ) is defined as the standard deviation of the system average price in different loading factors.

$$\Delta = std(\bar{\lambda}_s^{(l)}) \quad (3.13)$$

The market efficiency for each loading factor ( $\mu^{(l)}$ ) is defined as follow.

$$\mu^{(l)} = (\bar{C}_s^{MP,(l)} / \bar{C}_s^{DIS,(l)}) \times 100 \quad (3.14)$$

Where  $\bar{C}_s^{DIS,(l)}$  and  $\bar{C}_s^{MP,(l)}$  are the system average cost in discriminatory and marginal pricing approaches, respectively. The system average cost  $\bar{C}_s^{(l)}$  is obtained using (3.15).

$$\bar{C}_s^{(l)} = \left( \sum_{i=1}^{Iter} \sum_{g=1}^{NG} C_{g,i}^{(l)} \right) / Iter \quad (3.15)$$

Fig. 3.2 shows the framework for proposed algorithm. The algorithm is implemented in MATLAB programming environment.

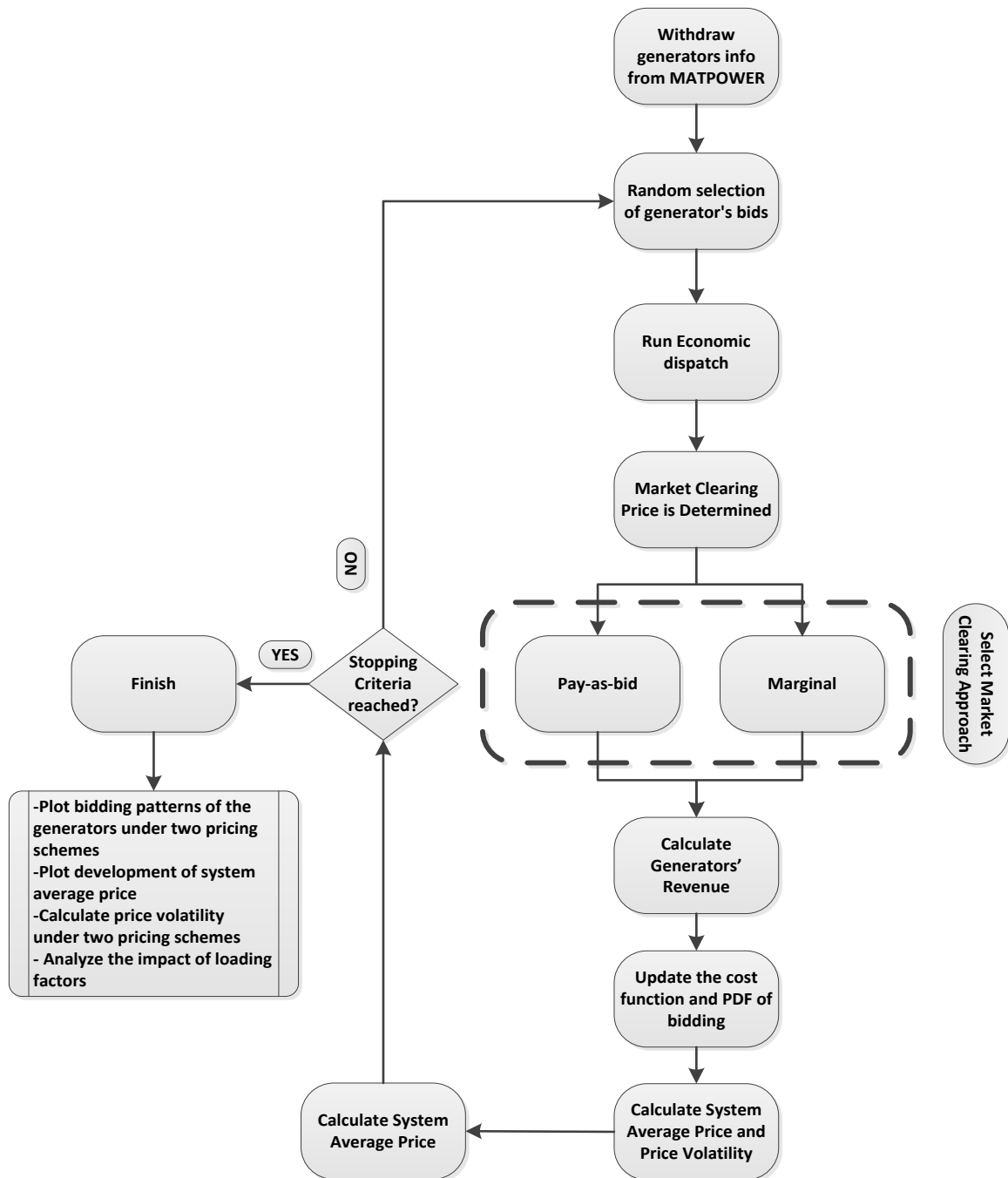

Fig. 3.2. Framework for the proposed algorithm

### 3.3.4 Simulation Results – 5 buses network

Simulation is carried out on the five nodes power system shown in Fig. 3.3. The system has three loads and four generators. The loads are assumed to be inelastic and constant. Sum of the demands shown in Table I is assumed as the base power with  $\omega = 0.59$ . The load distribution and the

corresponding probabilities are given in Fig. 3.4. The transmission lines and generators data are presented in Table II and Table III respectively. The price cap for the market is set to 50 \$/MW. It goes without saying that in DC ED lines are considered to be purely inductive which is compatible with the fact that  $R/X$  is relatively small in transmission lines. This is the reason that there is no resistive component in table II.

Each generator bids between its marginal cost and the price cap according to its PDF to maximize profit. The parameters of the agent based simulation,  $\alpha$  and  $M$ , are assumed equal to 0.05 and 10, respectively.

The system is studied in two scenarios for different wind penetration levels. The first scenario (SC1) represents low wind penetration level and considers  $\{G3\}$  as the wind generator. The second scenario (SC2) characterizes high wind penetration level by considering  $\{G3, G4\}$  as the set of wind generators. Note that the replaced wind generators have  $P_{gmax}$  same as the replaced generator(s), but their marginal costs are considered equal to 1 \$/MW.

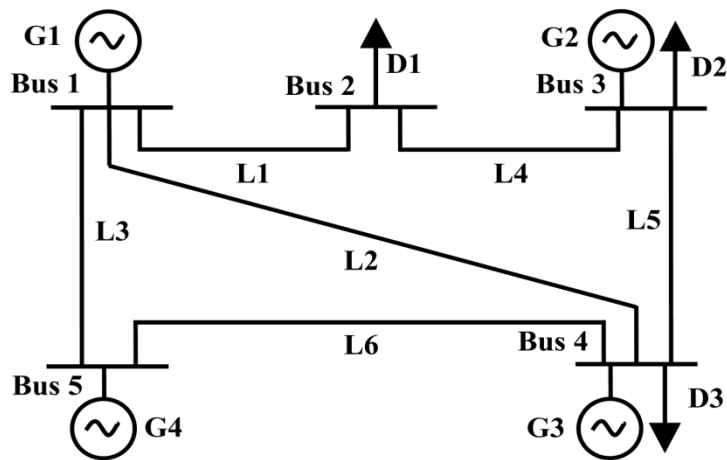

Fig. 3.3. One line diagram of five bus system

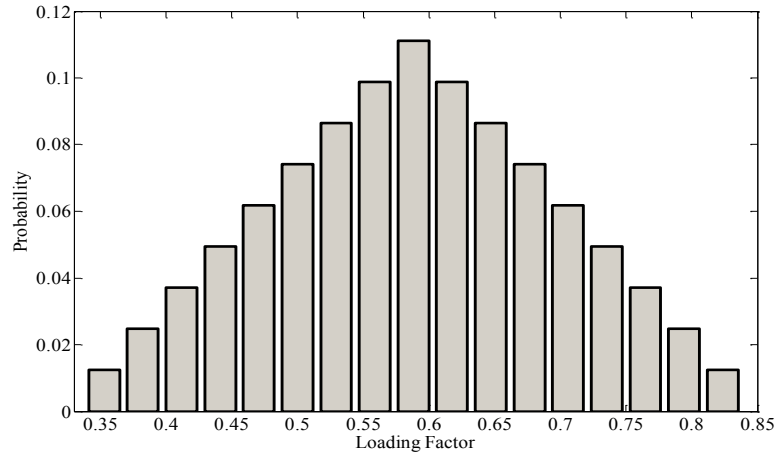

Fig. 3.4. Probability of different loading levels

TABLE I. LOADS DATA.

	D1	D2	D3
<b>Demand Power [MW]</b>	350	300	250

TABLE II. TRANSMISSION LINES DATA.

Line	Bus (from)	Bus (to)	$X$ (%)	$P_t^{max}$ [MW]
L1	1	2	2.81	450
L2	1	4	3.04	350
L3	1	5	0.64	600
L4	2	3	1.08	550
L5	3	4	2.97	440
L6	4	5	2.97	440

TABLE III. GENERATORS DATA.

	$P_g^{max}$ [MW]	$\lambda_g^{min}$ [\$/MWh]
G <sub>1</sub>	210	15
G <sub>2</sub>	520	25
G <sub>3</sub>	200	30
G <sub>4</sub>	600	10

In this section we primarily demonstrate bidding behavior of  $G_1$  and  $G_2$ . These two agents are chosen since their marginal prices are not modified in aforementioned scenarios. Fig. 3.5 and Fig. 3.6 illustrate the evolution of their bidding behavior for  $l = 0.59$  due to interaction with other market participants for revenue maximization. As shown in Fig. 3.5,  $G_1$  converges to the bidding strategy that maximizes its revenue after sufficient number of iterations. However,  $G_2$  has an unstable and changing bidding pattern, as illustrated in Fig. 3.6. That is due to high marginal cost of  $G_2$  that impedes its commitment in this particular loading condition. In other words, the PDF tries bidding from different segments, however none of them increases its revenue because it cannot be committed by bidding any of the segments. It means that the unit's marginal price is higher than MCP and there is not chance for the unit to be committed. The evolution of  $G_1$  and  $G_2$  bidding behavior for  $l = 0.82$  is demonstrated in Fig. 3.7 and Fig. 3.8, respectively. As it was expected, in low loading factors the discriminatory pricing mechanism ends up with higher average price levels (Fig. 3.5 and Fig. 3.7). In peak load conditions both discriminatory and marginal approach bid quite close to price cap so it can be observed that bids which make maximum revenue coincide in high loadings. It can be perceived in Fig. 3.8.

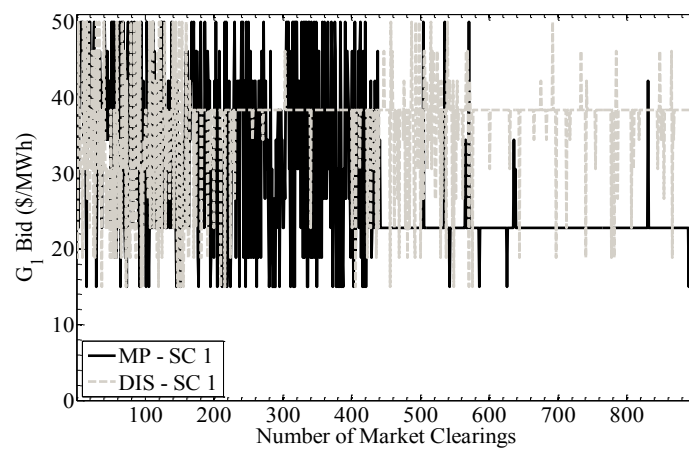

Fig. 3.5. Evolution of bids of  $G_1$  versus number of market clearings for SC1 with MP and DIS for loading factor  $l=0.59$

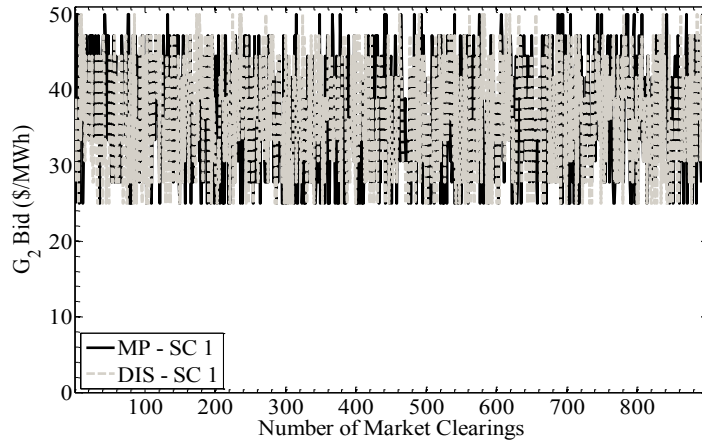

Fig.3. 6. Evolution of bids of  $G_2$  versus number of market clearings for SC1 with MP and DIS for loading factor  $l=0.59$

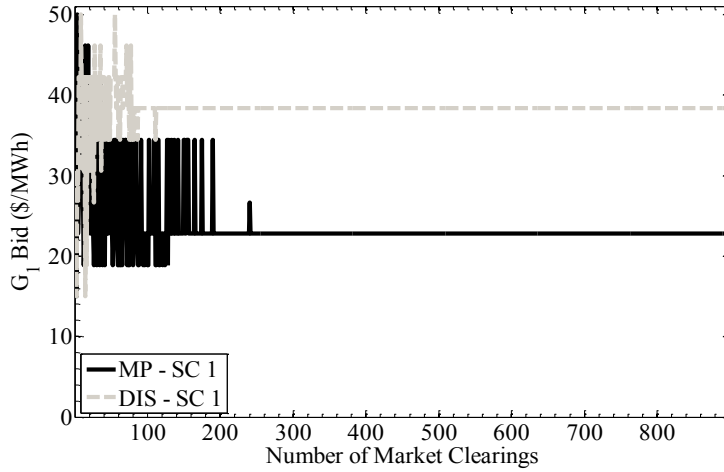

Fig. 3.7. Evolution of bids of  $G_1$  versus number of market clearings for SC1 with MP and DIS for loading factor  $l_{max}=0.82$

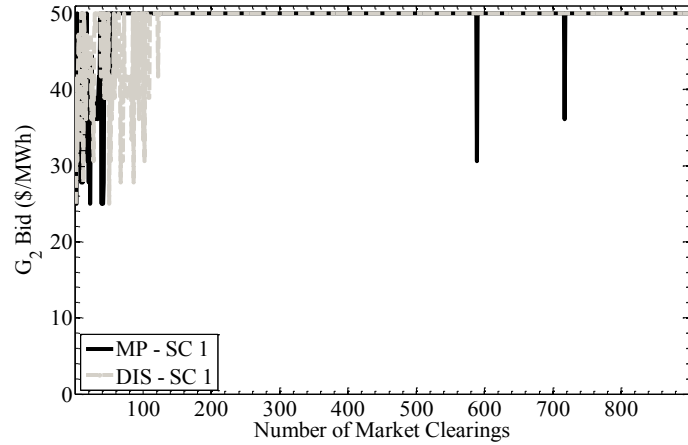

Fig. 3.8. Evolution of bids of  $G_2$  versus number of market clearings for SC1 with MP and DIS for loading factor  $l_{max} = 0.82$

In higher loading conditions both generators (agents) find their optimal bidding pattern after few iterations and reach a fixed bidding pattern that leads to revenue maximization. These patterns are observed in Fig. 3.7 and Fig. 3.8. It can be demonstrated that in higher loading conditions both agents have the opportunity to be committed, so after fewer number of iterations they will converge to the bid value which maximizes their revenue. Fig. 3.9 and Fig. 3.10 present system average price in two aforementioned scenarios. System average price is obtained using (3.4). In both scenarios, it is observed that in high loading factors discriminatory and marginal pricing mechanisms converge to same values while in low loading factors discriminatory approach avoids depressed prices

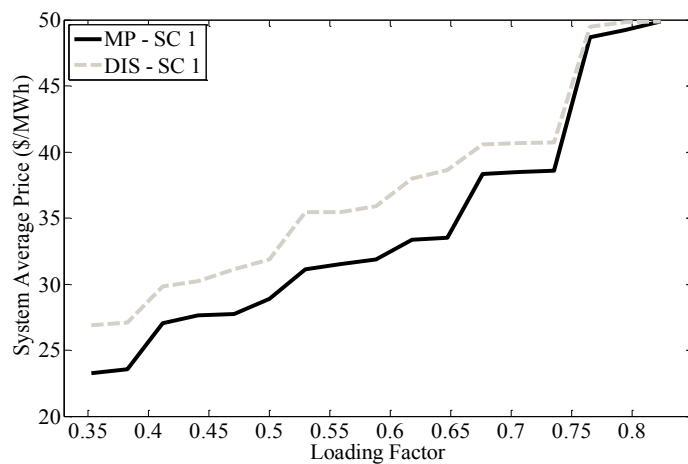

Fig. 3.9. System average price for SC1 with MP and DIS



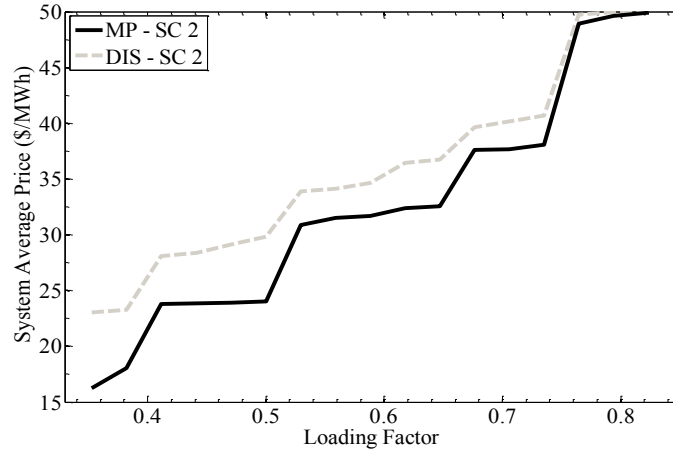

Fig. 3.10. System average price for SC2 with MP and DIS

Presented values in Table IV show the expected system average prices in both approaches. The expected system average prices of SC2 are lower because of higher penetration of inexpensive wind power generation.

TABLE IV. EXPECTED SYSTEM AVERAGE PRICE FOR TWO SCENARIOS WITH MP AND DIS.

Market Mechanism	SC 1 (\$/MWh)	SC 2 (\$/MWh)
MP	33.371	31.922
DIS	36.724	35.382

A *flat bidding curve*<sup>4</sup> under pay-as-bid approach decrease high price variations, which is shown in the result of test network in Table V applying two different scenarios. Note that higher wind penetration level in SC2 leads to higher difference between the price volatility of discriminatory and marginal pricing schemes.

<sup>4</sup> A flatter bidding curve under pay-as-bid scheme is an accepted economic fact. The reason is that units bid close to MCP to gain highest financial gain and that makes a flatter supply function in comparison to uniform pricing (where the units bid their marginal price and have no incentive to bid close to MCP).

TABLE V. PRICE VOLATILITY FOR TWO SCENARIOS WITH MP AND DIS.

Market Mechanism	SC 1 (\$/MWh)	SC 2 (\$/MWh)
MP	8.5043	10.3779
DIS	7.4696	8.5756

### 3.3.5 Simulation Results – 24 buses network

In order to better verify the experimental, a larger scale system rather than the previous 5-bus tests system is also used. IEEE 24-bus reliability test grid is used here as the test grid. This test grid will yield a robust verification of proposed methodology with relatively high number of agents. The employed test system has 33 generation units. We have considered three of them in buses 17, 21 and 22 to be wind farms. More detailed information about IEEE reliability test system can be found in [19]. Fig. 3.11 shows a single line diagram of the test grid. Wind penetration is about 38% of total generation capacity, which is a significant wind power penetration. This high wind penetration level is inspired by current wind percentage of western Danish power system. Power system decision makers in Denmark have plans for even higher percentages in coming years. The load is considered to be constant and inelastic. The nominal value for the load at buses that have a load connected to them is considered as in original IEEE 24-bus reliability test system. We present bidding behavior of different agents and the corresponding impact under uniform and discriminatory pricing mechanisms in this part.

Implementing the proposed learning algorithm, Fig. 3.12 and Fig. 3.13 show the bidding behavior of two agents with low and high marginal prices respectively. While the agent in Fig. 3.12 has a changing and not converging behavior, agent in Fig. 3.13 converges to a fixed value after sufficiently high number of iterations. This value is the optimum bidding strategy that maximizes the agent revenue implementing the agent's gained experience in about first 200 iterations.

The reason for the difference in the bidding patterns is that the agent with high marginal price cannot be committed as there are less expensive units for serving the load. However for the unit with very low marginal price the bidding pattern will find its optimal bidding strategy (which maximizes its revenue) after certain number of iterations. To investigate the repeatability of the convergence of the unit with very low marginal price we conducted the experiment in a higher load

factor (20% higher loading than nominal load). As can be seen from Fig. 3.14 the bidding pattern of the agent does converge and in less number of iterations (about 100 iterations). Although the bidding behavior of this agent with very low marginal cost converges to a fixed value but the experiment showed that under uniform pricing mechanism most agents have a changing and non-converging bidding behavior. These patterns are generally known feature of uniform mechanism in which agents have weak learning characteristics [9].

System average price also evolves as the agents learn how (or what) to bid to make maximum financial revenue. System average price shows how much an additional megawatt will add to system operation cost (price is the Lagrange multiplier of power balance equality when no congestion exists). It should be noticed that price remains the same in all nodes only if transmission constraints are not violated. When the power flow hits its capacity limit in a given line the nodal price will be different on two sides of the line, otherwise the LMP will be the same. In this situation the price difference between two nodes at both sides of the congested line can be calculated by having the Lagrange multiplier of associated line capacity inequality and the shift factor matrix. Shift factor matrix shows the sensitivity of power flow in each transmission line to the injection of power to different buses in the grid [10].

Fig. 3.15 shows the evolution of system average price in 900 iterations under uniform approach (900 times of solving economic dispatch problem with evolving bidding values by 33 agents in the test grid). Although system average price variations decrease significantly as the first 300 iterations are passed, the bidding behavior is not very well converged and there are still variations after large number of market clearing experiences. As mentioned previously, this poor convergence characteristic is due to fluctuating and changing pattern of most generation units (agents) under uniform pricing mechanism.

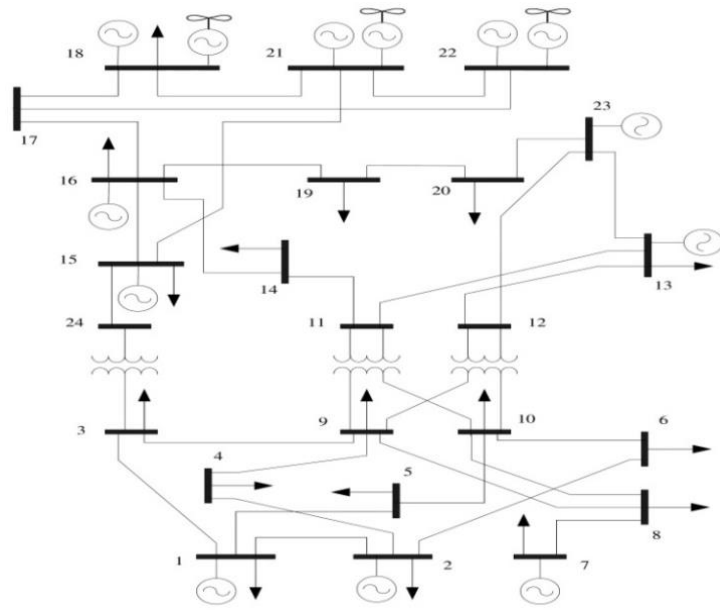

Fig. 3.11. IEEE 24 buses reliability test network

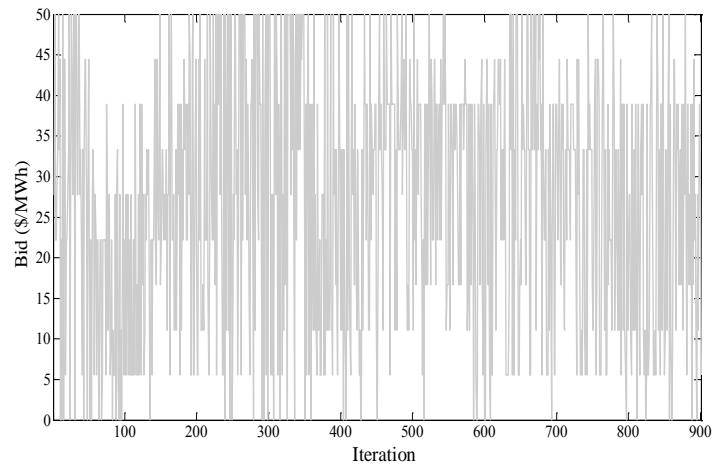

Fig. 3.12. Bidding pattern of a high marginal price agent under uniform approach

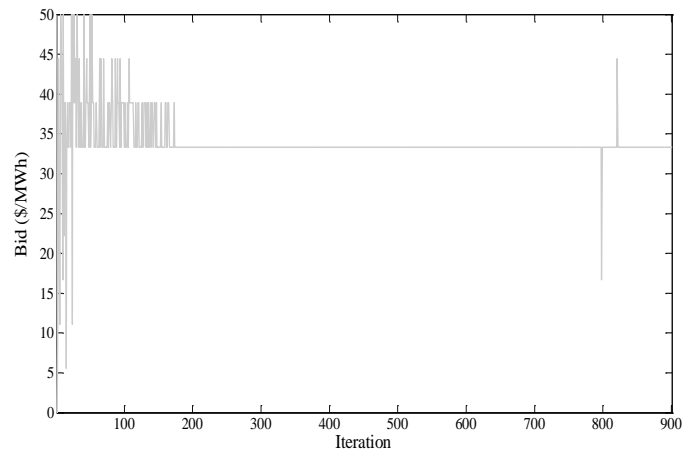

Fig. 3.13. Bidding pattern of a low marginal price agent under uniform approach  
(medium system loading condition)

One may argue about the adequacy of the chosen number of iterations. Fig. 3.16 depicts the evolution of defined stopping criterion in equation 3.12. It is observed that the stopping criterion has passed its primary transients and thus the chosen number of iterations is sufficiently high to capture the agents' bidding behavior. As discussed in section II agents start bidding to the market based on a probability density function (PDF) that is uniform in the first iteration and evolves considering market participation experiences. The PDF is portioned into 10 segments here. The number of the segments will affect the smoothness of the gained PDF in last iteration. As shown in Fig. 3.17 the floor of the segments is the unit's marginal price. The reason obviously is that in such a competitive framework no rational agent bids below its own marginal cost. The cap is set by market operator. Fig. 3.17 shows the PDF of two market agents after sufficiently high number of iterations, one with a very low marginal price that can be committed easily and the other one with relatively high marginal cost with non-converging bidding characteristic. This figure shows the PDF by which agents maximize their revenue. It can be observed that the PDF of the agent with low marginal cost is accumulated around a certain segment which is most likely to maximize agent's revenue. However, the other agent with relatively higher marginal cost is scattered in almost all the segments between unit's marginal cost and bid cap. These PDFs can be used as a guideline for unit owner to participate in the market more targeted. Market operator might also use this information to forecast system operation cost and system payments to unit owners. In a smart grid where significant load service entities also bid their additional power to market they may be modeled like a generation unit. Price volatility is calculated as the standard deviation of the system average price in different loading factors.

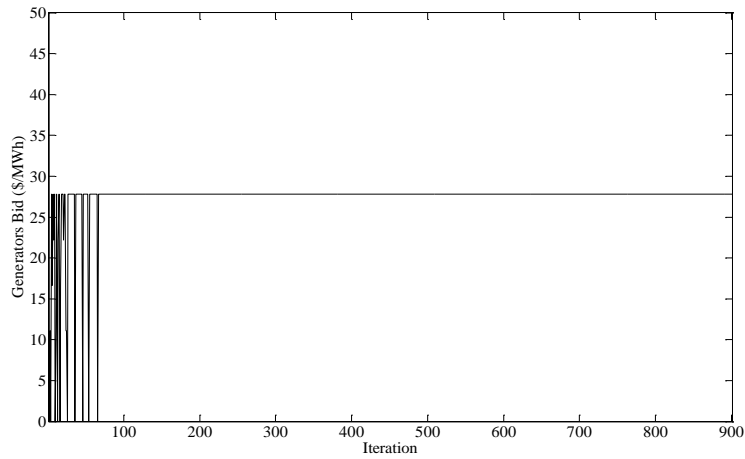

Fig. 3.14. Bidding pattern of a low marginal price agent under uniform approach  
(High system loading condition)

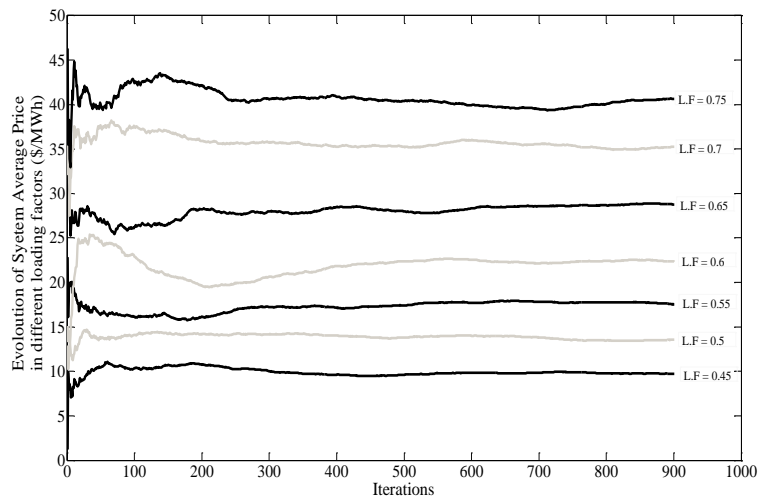

Fig. 3.15. Evolution of system average price in different loading factors under uniform approach

Many market experts traditionally believe that under pay as bid pricing mechanism agents will soon learn to *guess* the market clearing price, and then will bid just below that for a maximum financial gain. Agent based economic studies show that in a discriminatory pricing scheme the average market clearing price will gradually increase. Also, a more flat supply function in this pricing scheme will make it less likely to intersect demand function in different points and thus less volatile prices are experienced in the market under this pricing scheme. Simulation results here repeat the presented discussion in the previous part but under pay as bid pricing mechanism. It is

observed from the obtained patterns that market agents' bidding strategy converge to a fix value after sufficiently high number of iterations.

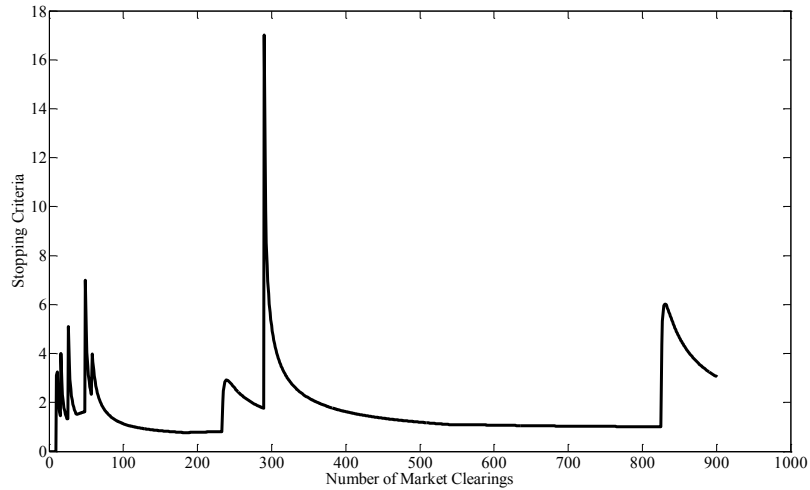

Fig. 3.16. Stopping criteria under uniform approach

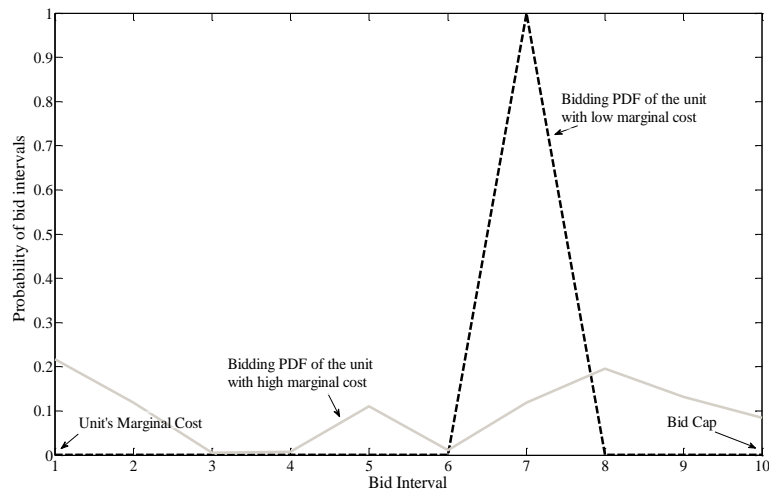

Fig. 3.17. PDF of agents with different marginal prices

Quick learning ability of agents is confirmed by empirical studies. As expected the *convergence speed* is higher in high loadings (explanation in previous sub-section). Fig. 3.18, Fig. 3.19 and Fig. 3.20 illustrate the bidding pattern of 33 agents in low, medium, and high loading conditions. Fig. 3.21 shows the stopping criteria under pay as bid pricing mechanism. It is observed that under uniform scheme the primary transients vanish after fewer market clearing times which corroborates

the better learnability of agents under pay as bid pricing mechanism (Comparing Fig. 16 and Fig. 21 shows the sudden changes are vanished faster under pay-as-bid scheme). Also, although stopping criteria gently increases in the Fig. 3.21, it remains in the defined range. Fig. 3.22 shows the evolution of system operation cost under pay-as-bid scheme. It can be observed that price evolution is very smooth and by applying proposed algorithm agents have higher learnability under pay-as-bid scheme (which was expected). Obviously, system average price is higher in high loading conditions.

In Fig. 3.23, evolution of bidding-PDF for three generators is shown. The process is shown in four steps (iterations). Three agents are shown in a way to represent all 33 units in terms of generation cost. The solid line is the unit with low marginal cost, the dash line is the unit with medium marginal cost, and the solid-dash line is the unit with high marginal cost. As mentioned in problem formulation part, the proposed algorithm divides the space from a unit marginal cost and the price cap which is set by market operator into some segments (here 10 segments).

The probability of choosing a particular segment will be increased if bidding that particular segment elevates the unit's revenue. In the first interactions (market participations), generators bid according to the uniform PDF. For this reason bids are very different in comparison with their normal values (this is the training period). As iterations increase (market clearing experiences increase) the PDFs are more targeted and bid volatility is reduced. The sudden changes in the early iterations of stopping criteria in Fig. 3. 16 and Fig. 3. 17 are due to this reason.



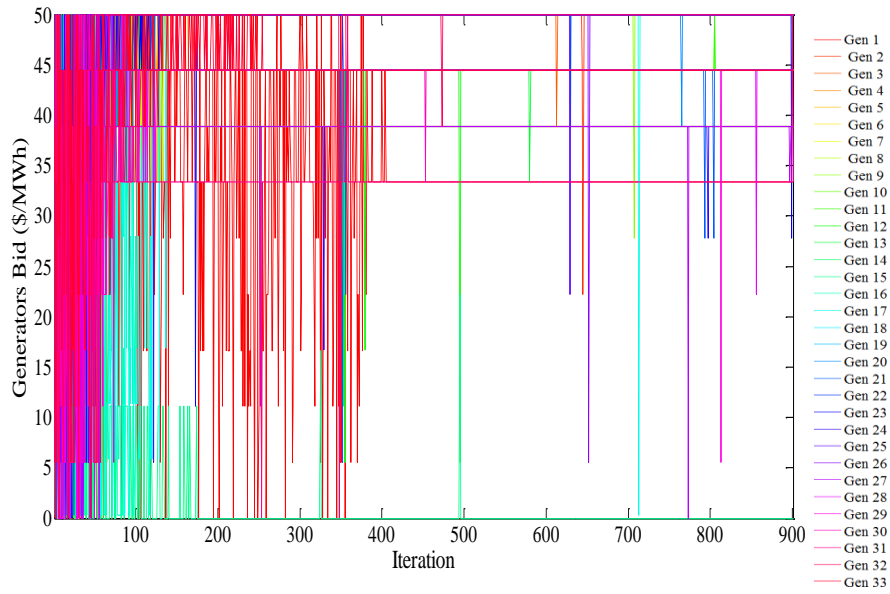

Fig. 3.18. Bidding pattern of an agent under pay-as-bid approach  
(low system loading condition)

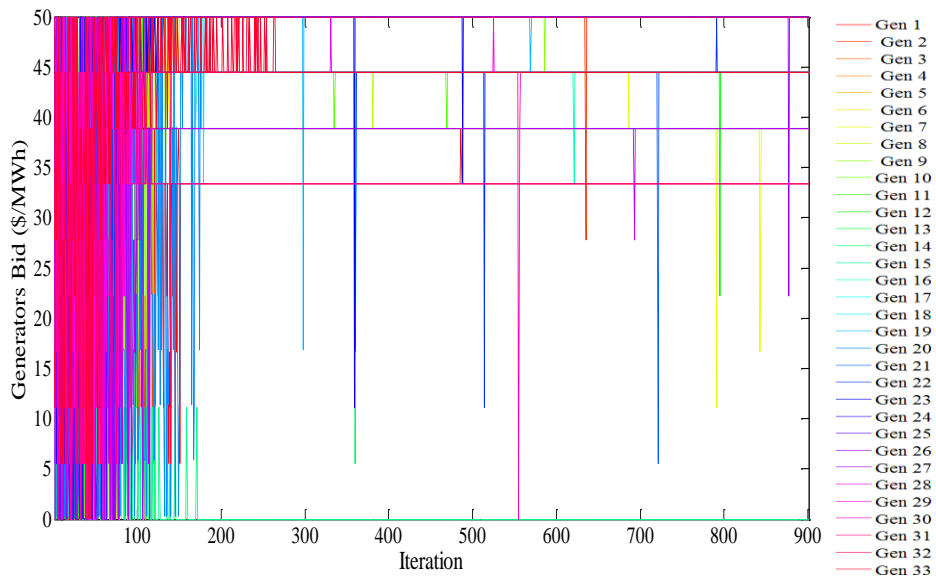

Fig. 3.19. Bidding pattern of an agent under pay-as-bid approach  
(medium system loading condition)

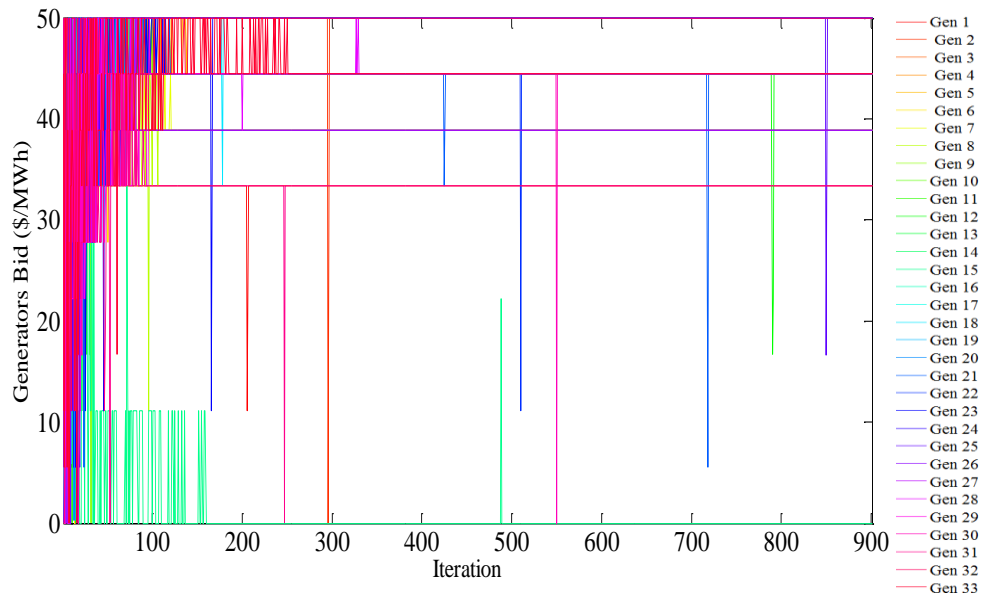

Fig. 3.20. Bidding pattern of an agent under pay-as-bid approach  
(high system loading condition)

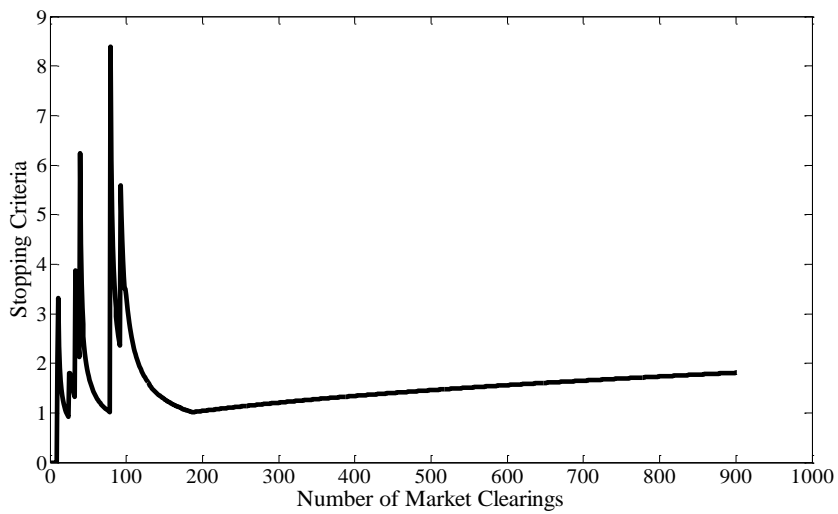

Fig. 3.21. Stopping criteria under pay-as-bid approach

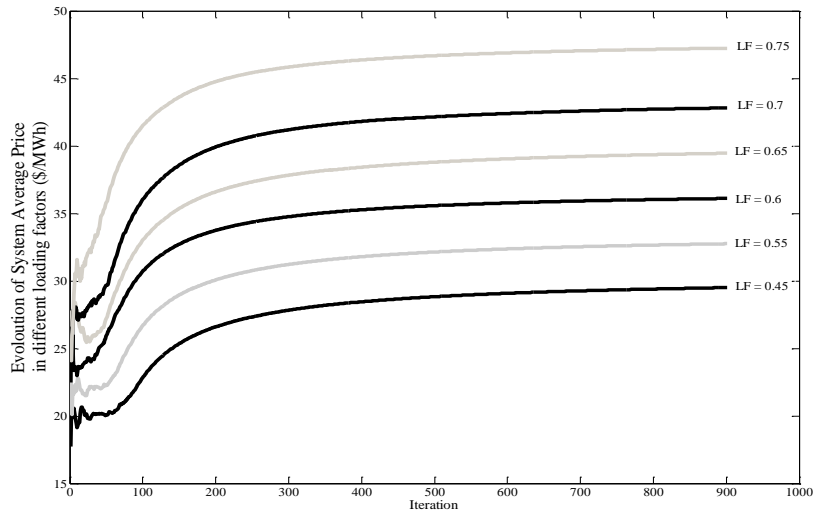

Fig. 3.22. Evolution of system average price under different loading factors- under pay-as-bid approach

The last row in Fig. 3.23 shows the probability of bidding different segments, which, if chosen the unit financial revenue will be maximized. In all iteration the area under PDF curve is equal to unity and an increase in the probability of one segment decrease the probability of selection of other segments. The change among PDFs from 100<sup>th</sup> iteration to 900<sup>th</sup> iteration is almost negligible which is consistent with convergence of bidding patterns after approximately 100 iterations.

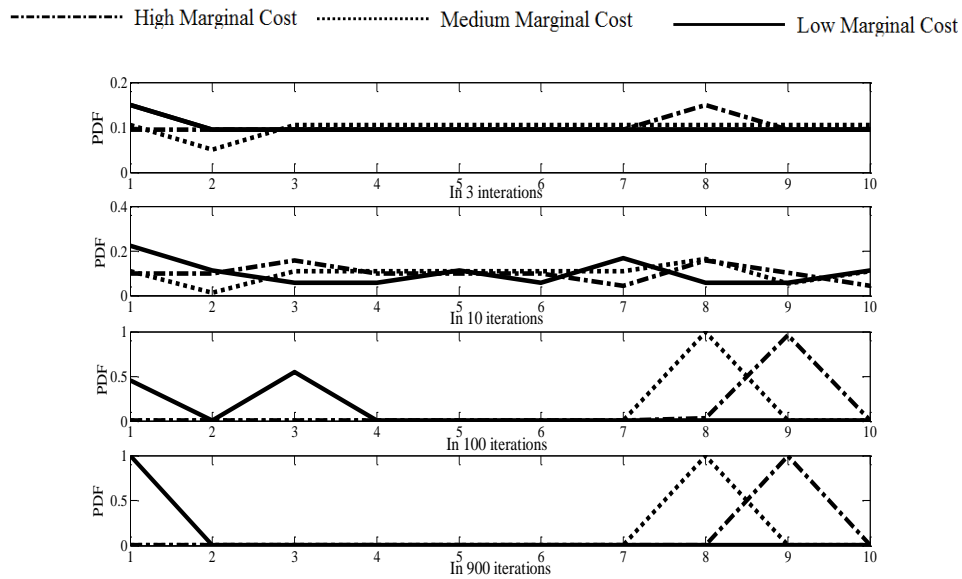

Fig. 3.23. Evolution of the PDF of three agents with low, medium, and high marginal cost

In this part we focus on the main contribution of this study which is investigating how two mentioned approaches can overcome the emerging problems in a wind dominant electricity market. These problems are twofold: First, excessive price reduction which discourages generation expansion and thus undermines the adequacy of total generation capacity. And second, highly volatile prices in grids with significant penetration of intermittent renewables. Comparison between Fig. 3.15 and Fig. 3.22 shows that prices are gently elevated under pay as bid pricing mechanism. This can be observed in all loading conditions. Particularly in low loading conditions in which the system price is excessively low. As expected, the price volatility is reduced under pay as bid scheme. Table VI compare the price volatility characteristics of the agents with different loading factors. It should be noted that here there is no intention to investigate the impact of wind penetration on price volatility but to show how price volatility indices is affected by the market clearing approach in certain wind penetrations.

TABLE VI. PRICE VOLATILITY UNDER TWO PRICING MECHANISMS

Loading Factor	Uniform	Pay-as-bid
0.4	7.2265	2.2762
0.5	5.6584	3.243
0.6	11.1569	2.45
0.7	6.554	4.732
0.8	5.59	5.3669

### 3.4 Discussion

In this study market efficiency indices are defined by the cost of providing load under uniform pricing mechanism over the same cost under pay-as-bid pricing mechanism (see equation (3.14)). Assuming that all agents have revealed their true marginal cost, the merit order logic of the economic dispatch implies that solution is the least expensive among all commitment possibilities. Many auction experts believe that uniform pricing mechanism has superiority over pay as bid clearing settlement in terms of efficiency. This can be particularly true in a liquid and concentrated market for homogenous commodities. In uniform approach, generators have an incentive to bid their true marginal cost and therefore, the merit order dispatch will be efficient while in pay-as-bid

clearing framework bidders know in advance that they will be remunerated at their bid level and not the market clearing price. As a result, they do not have any incentive to reveal their true marginal cost and what actually occurs is trying to guess the market clearing price and bid just below that. Agents usually prefer to keep a safety margin to avoid not being committed. As the declared bid level is not necessarily the true marginal cost of agents, and imperfect information about the intersection of supply and demand curves cause the bidders to make wrong forecasts, the market efficiency is slightly lower under pay-as-bid clearing settlement. As units reveal their true marginal cost under uniform scheme, the system operation cost is minimum under this approach. Under pay-as-bid approach, the system operation cost might be higher as committed units are not necessarily least expensive. The market efficiency is defined as system operation cost under uniform approach over this value under pay-as-bid scheme. The degree of perfectness of agents' information about the cost of other agents, calls for modelling the problem with a game theory framework that is out of scope in this research.

An idea to treat comparatively lower efficiency in pay-as-bid approach is multi bid cap values for different technologies. In this framework cap values set by market operator for different technologies are designed in accordance to typical marginal price of the units, for instance a low cap for wind farms, a medium cap for coal power plants, and a high cap for gas burning technology which are the most expensive units. This categorization prevents the commitment of an expensive unit while a comparatively cheaper one is uncommitted and will improve the defined market efficiency indices. However, analysis of the functionality of this idea needs further research. In this study market efficiency indices are defined by the cost of providing load under uniform pricing mechanism over the cost of providing load under pay-as-bid pricing mechanism. Assuming that all agents have revealed their true marginal cost, the merit order logic of the ED implies that solution is the least expensive among all commitment possibilities.

The other aspect that can have considerable impact on optimal bidding strategy of a generation unit is its capacity. The size of the generators are very important on the power market and consequently on the bidding strategy in a competitive electricity market. Market power indices are introduced in the literature considering different criteria [20]. Most of the traditional indices consider the size of the generation unit. One of the known measures which is widely practiced by market operators is that the size of generation units should be maximum 20% of total generation capacity. In our study this criterion is respected and the capacity share of all generators is below the mentioned limit,

nevertheless this criteria is criticized as the ability of a company with 20 percent market share to exercise market power may be different when that company is the largest player in a largely deconcentrated market, versus being the second or third largest player in a highly concentrated market [21]. The Hirschman-Herfindahl Index (HHI) is probably the most known index considering the size of the firms in a specific market [22].

### 3.5 Summary

This chapter presents a comparative study between uniform and pay-as-bid pricing mechanisms in power systems with significant wind power penetration. High volatility and excessively reduced price are introduced as two problems in power systems with very high wind penetration. Uniform scheme is introduced and tested here as it is famous to decrease the volatility and increase the price. So the whole study is based on this conjecture that pay-as-bid might be considered as an alternative scheme (to be replaced by currently used uniform scheme). An agent based simulation methodology is presented for modeling bidding behavior of market agents (power generation companies). System price and volatility are the two criteria that have been investigated. It is shown that under the pay-as-bid pricing mechanism the two mentioned problems are alleviated (Table IV and Fig. 3.9 and Fig. 3.10, in addition to comparison between Fig. 3.15 and Fig. 22 shows that price is higher under pay-as-bid scheme).

However, simulation results reveal that system operation cost is higher under pay-as-bid scheme (introduced market efficiency indice is always smaller than unity). This is in line with numerous experimental studies in economic and operations research (for other commodities rather than electricity) showing that under pay-as-bid auction the merit order of the economic dispatch may be distorted<sup>5</sup> [9], [23]-[24].

---

<sup>5</sup> Bidders will try to anticipate the clearing price which leads to a flat supply function and prices creep up. In addition as people make errors in forecasting the clearing price, merit order is distorted which causes efficiency losses

## References:

- [1] J. M. Morales, A. J. Conejo, J. Pérez-Ruiz, "Simulating the Impact of Wind Production on Locational marginal prices", *IEEE Trans. Pow. Syst.*, vol. 26, no. 2, May 2011, pp. 820 – 828.
- [2] H. H. Zeineldin, et all, "Impact of wind farm integration on electricity market price", *IET Renewable Pow. Gen.*, vol.3, no.1, 2009, pp. 84 – 95.
- [3] W. Hu, Z. Chen, B. Bak-Jensen, "The Relationship between Electricity Price and Wind Power Generation in Danish Electricity Markets", *IEEE APPEEC*, 2010, pp.1 – 4.
- [4] W.L. Kling, B.C. Ummels, E. Pelgrum, R.A. van Offeren, "Case study for the integration of 12 GW wind power in the Dutch power system by 2020", *CIGRE/IEEE PES joint symposium*, 2009, pp. 1 – 11.
- [5] N. Troy, S. Twohig, "Wind as a price-maker and ancillary services provider in competitive electricity markets", *IEEE PES GM*, 2010, pp.1–6.
- [6] W. W. Hogan, "An “Energy Only” Electricity Market Design for Resource Adequacy”, Harvard University, September 2005.
- [7] Y. Ren, F. D. Galiana, "Pay-as-Bid versus Marginal Pricing—Part I: Strategic Generator Offers", *IEEE Trans. Pow. Syst.*, vol. 19, no. 4, November 2004, pp. 1771 – 1776.
- [8] Y. Renand, F. D. Galiana, "Pay-as-Bid versus Marginal Pricing—Part II: Market Behavior under Strategic Generator Offers", *IEEE Trans. Pow. Syst.*, vol. 19, no. 4, November 2004, pp. 1777 – 1783.
- [9] S. Oren, "When is a Pay-as Bid Preferable to Uniform Price in Electricity Markets", *IEEE PES GM Conf*, 2004, pp. 1618 – 1620.
- [10] H. Chen, "Experimental analysis of uniform price and PAB auctions in electricity market”, *IEEE IPEC Conf*, 2007, pp. 24 – 29.
- [11] Astaneh, M.F.; Zhe Chen; Mousavi, O.A., "Excessive price reduction and extreme volatility in wind dominant electricity markets; solutions and emerging challenges," *Power and Energy Society General Meeting (PES)*, 2013 *IEEE* , pp.1,5, 21-25 July 2013.
- [12] H. Rajabi Mashhadi and M. Rahimiyan, "Measurement of power supplier’s market power using a proposed fuzzy estimator, " *IEEE Trans. Power Syst.*, vol. 26, pp. 1836–1844, 2011.
- [13] Z. Zhou, F. Zhao, and J. Wang, "Agent-based electricity market simulation with demand response from commercial buildings, " *IEEE Trans. Smart Grid*, vol. 2, pp. 580–588, 2011.

- [14] S. Mohtavipour, M. Haghifam, M. Sheikh-El-Eslami, "Emergence of capacity withholding: an agent-based simulation of a double price cap electricity market, " *Gener. Transm. Distrib. IET.*, vol.6, no.1, Jan. 2012, pp.69,78.
- [15] D. W. Bunn and F. S. Oliveira, "Agent-based simulation - An application to the new electricity trading arrangements of England and Wales, " *IEEE Trans. Evol. Comput.*, vol. 5, pp. 493–503, 2001.
- [16] P. M. Subcommittee, "IEEE Reliability Test System, " *IEEE Trans. Power Appar. Syst.*, vol. PAS-98, 1979.
- [17] N. Yu, C. Liu, L. Tesfatsion, "Modeling of Suppliers' Learning Behaviors in a Market Environment," *Int. J. Eng. Intell. Syst.*, vol. 15, no. 2, 2007, pp. 115 – 121.
- [18] Luonan Chen; Suzuki, H.; Wachi, T.; Shimura, Y., "Components of nodal prices for electric power systems," *IEEE Trans. Power Syst*, vol.17, no.1, pp.41,49, Feb 2002.
- [19] C. Li, R. B. Johnson, A. J. Svoboda, "A New Unit Commitment Method *IEEE Trans. Power Syst.*, Vol. 12, No. 1, Feb. 1997, pp. 113-119.
- [20] S. Prabhakar Karthikeyan, I. Jacob Raglend, and D. P. Kothari, "A review on market power in deregulated electricity market, " *Int. J. Electr. Power Energy Syst.*, vol. 48, pp. 139–147, 2013.
- [21] Paul Twomey, Richard Green, Karsten Neuhoff and David Newbery, "A Review of the Monitoring of Market Power: The Possible Roles of Transmission System Operators in Monitoring for Market Power Issues in Congested Transmission Systems", Center For Energy and Environmental Policy Research, Massachusetts institute of technology, 2009.
- [22] A. Kanagala, M. Sahni, S. Sharma, J. Yu, "A probabilistic approach of Hirschman-Herfindahl Index (HHI) to determine possibility of market power acquisition, " *Power Syst. Conf. Expo*, 2004. IEEE PES , pp.1277,1282 vol.3, 2004.
- [23] Susan F. Tierney, Todd Schatzki, Uniform-Pricing versus Pay-as-Bid in Wholesale Electricity Markets: Does it Make a Difference?, NewYork ISO, Technical report, March 2008, available online:  
[http://www.nyiso.com/public/webdocs/media\\_room/current\\_issues/uniformpricing\\_v\\_payasbid\\_tierneyschatzkimukerji\\_2008.pdf](http://www.nyiso.com/public/webdocs/media_room/current_issues/uniformpricing_v_payasbid_tierneyschatzkimukerji_2008.pdf)
- [24] A. E. Kahn, P. C. Cramton, R. H. Porter, and R. D. Tabors, "Uniform Pricing or Pay-as-Bid Pricing, " *The Electricity Journal*, vol. 14. pp. 70–79, 2001.



## Chapter 4

### Economic Operation of Wind-Storage Facilities

#### 4.1 Cooperative operation of wind-storage units

With growth in wind power penetration, deviation of wind power realization from the forecasted level becomes an issue. Storage units are reliable tools to mitigate wind power deviations. However many types of storage such as batteries are not still economically viable due to their huge investment cost. As a result, to consider installing storage units as a promising investment, the wind farm owner should see other benefits than just mitigating the imbalances.

In this chapter we suggest benefitting the Lithium-Ion battery units as regulation service providers (beside its operation for wind imbalance mitigating). This idea is inspired by the fact that storage units have very fast ramping capabilities which is vital for regulation needs. We present a formulation framework to investigate optimal operation of a storage unit considering power system balancing conditions and wind power imbalances.

#### 4.2 Literature review and introduction

While market regulations tend to become stricter in coming years, to pave the way for better utilization of higher share of intermittent renewables, penalizing any deviation from the scheduled levels seems to be inevitable.

The way the deviation penalties are applied differs in different market structures. For example, in many electricity markets in US, a wind producer, like any other producer, is penalized only if its deviation is in the direction of the system deviation [1]. That is, if the system net condition is deficit then producers that under-generate are penalized and those that produce more than already submitted bids, will not be penalized and they get paid by real time market price. Similarly if the system net condition is surplus the units that over generate are penalized but those that generate less than their scheduled level are not penalized (they are instead remunerated by real time price). In this scheme the units which their deviation is in the opposite direction of the system net balance are not rewarded.

In other words a wind unit is penalized if the associated deviation is in the same direction with the system net imbalance, however there is no reward in conditions that the wind unit's over/under generation contribute for mitigating the system imbalance. In this study, we investigate how storage participation in a regulation market can affect its role as a tool for mitigating imbalances. It should be noted that in order to be able to quantify the actual *market value* of the regulation services it is assumed that there is a regulation market in place (rather than an ancillary service which is usually by long term contracts). Although the real-time market, or *balancing market*, is the last *trading* floor, which usually clears between 5 to 60 minutes ahead, However, *regulation* is a technical, and not trading, floor, i.e., it is an ancillary service, to compensate the load deviations at the moment of operation. There are a limited number of units (highly fast ones) that can provide the regulation services, e.g., hydro units and storage units. Thus balancing and regulation terms may usually be replaced. The steps to accomplish this goal are twofold:

*Approach 1:* The only function of the battery unit is to mitigate wind power fluctuation. It does not participate on the regulation market. The battery unit hedges possible penalties due to deviations from the scheduled level.

*Approach 2:* The storage unit mitigates the wind power deviations and has the possibility to independently participate in the regulation markets.

Several methods are suggested for mitigating wind power imbalances in the literature. In order to reduce the balancing needs, the idea of re-scheduling the wind power close to delivery time is proposed in [2]. The key contribution is to analyze internal ex-ante self-balancing. The optimal trading decisions in different situations are given as results. A hydro-thermal generation portfolio similar to that of Sweden is used. Nordic electricity market general framework is employed as the market framework.

A risk-averse optimization model for trading wind energy under uncertainty is proposed in [3]. A scenario-based stochastic optimization methodology is used. The uncertainty is in the energy market prices. A risk related term is added to problem's objective function to incorporate the risk aversion of the wind generation company. A similar study is done in [4] where a risk-constrained bidding strategy for wind power is developed. Adjustment markets are suggested to reduce wind power imbalances. Conditional value of risk (Cvar) tool is applied to incorporate risk attitude of wind power producer. In [5] the impact of short term storage technology in stabilizing the frequency response is studied. The frequency response is studied using Automatic Generation Control (AGC)

module. The storage unit is shown to reduce frequency deviations. In [6] and [7] a vanadium redox flow battery is proposed to be used to avoid wind power deviation. A short term strategy to reduce imbalance cost in Dutch power system is presented in [8]. A multi-stage stochastic optimization framework is used, maximizing wind power producer's revenue using cross-border intraday market. Several references have suggested using storage units for close to real time balancing purposes [9]-[11]. A detailed literature overview on storage deployment for easing high renewable integration is given in [12]. In [13] FERC order 755 addresses institutional barriers for storage resources in US. In [14] engineering-economic models of four fast-ramping storage technologies are presented and their cost-effectiveness are examined. In [15] ramping impact of wind power on power system operation is explained in detail. A similar study in [16] and [17] consider the ramping rate of electricity generation technologies for providing ancillary services particularly regulation.

A dynamic optimization problem is proposed in [18] incorporating the ramping rate of hydro power. The optimization problem is solved under different restrictions for water flow. It is shown that ramping restrictions cause a redistribution of hydro production over a given day. In [19] fast storage devices are being investigated in pilot implementations for providing ancillary services. A detailed dynamic model is developed for ISO operations. The model includes central power plants, intermittent renewables, loads, regulation, and AGC. Regulation price duration curve is given as results.

Two studies considering optimal operation of storage units on Danish power system are given in [20] and [21]. Western Danish electricity market's data is incorporated in the model. It is concluded that storage units bring economic flexibility to power system with extremely high wind penetrations such as Denmark with nearly 40% wind penetration. Having a control engineering point of view, [22] and [23] discuss designing controllers for cooperative Wind Storage Facilities (WSF)s. Studies on Danish power system should be focused carefully as extremely high penetration of wind power in Denmark can represent future power systems in many other parts of the world. In [24] integration of flexible consumers for providing ancillary service in Danish power system is investigated. Consumer's potential for contributing to primary, secondary, and tertiary service is shown. An aggregator model is assumed where it continuously adjusts the operational schedule. Various computational methods are run on the model. In this chapter we study a wind farm facilitated by a Lithium-Ion battery unit. The wind farm and the battery unit are operated and owned by the same entity. The wind farm owner invests on battery unit to increase dispatchability and also to mitigate wind power deviation penalties. The primary contribution of this chapter is to study the optimal

cooperative operation of wind and battery units while the main role for storage unit is twofold; first mitigating penalties due to the deviation of actual wind power generation from day-ahead forecast, and second to provide regulation service when needed. For this end, the intuitive compromise considering Power System Balancing Condition (PSBC) and wind power forecast error is explained. Then the mathematical formulation and results are presented.

### 4.3 Storage system role

In regards to system balance and wind power imbalances, there are four plausible scenarios: 1) System condition surplus–Wind power higher than scheduled (S-H); 2) System condition surplus–Wind power lower than scheduled (S-L); 3) System condition deficit–Wind power higher than scheduled (D-H); 4) System condition deficit–Wind power lower than scheduled (D-L). In this study, the Storage Unit (SU) can have two roles:

*First, storage unit is solely used to mitigate wind power deviations*

- 1) *S-H* The difference (extra power from the scheduled) is injected to the storage unit. The penalty will be hedged.
- 2) *S-L* Storage unit does not take any action. The available wind power is given to the grid. The deviation is settled with real time price.
- 3) *D-H* Storage unit does not take any action. The available power is given to the grid. The deviation is remunerated by system real time price in that particular hour.
- 4) *D-L* The difference (remaining power to meet the scheduled) is injected by the storage unit. The penalty is hedged.

These scenarios are mathematically formulated. The market mechanism used in this study assumes that deviation in the direction with system overall imbalance is subject to penalty and the deviation in opposite direction with system overall imbalance are not penalized, instead they are remunerated by real time price. For instance, if wind power is lower than forecast, it will be penalized only if the Power System Balance Condition (PSBC) is deficit. If PSBC is surplus, there will be no penalty. Table I shows the way the revenue is calculated in different scenarios helping a numerical example:

ILLUSTRATION OF EMPLOYED MODEL WITH A NUMERICAL EXAMPLE.

	Scheduled wind power (MW)	Realized Wind Power (MW)	Revenue calculation	Storage action required?
S-H	8	10	$8\pi^{DAM} + 2\pi^{RT} - 2\beta^6$	Yes
S-L	8	6	$8\pi^{DAM} - 2\pi^{RT}$	No
D-H	8	10	$8\pi^{DAM} + 2\pi^{RT}$	No
D-L	8	6	$8\pi^{DAM} - 2\pi^{RT} - 2\beta$	Yes

Second, storage unit is used to mitigate wind power deviations and participates in regulation market (penalty only scheme)

- 1) *S-H* The extra power from the scheduled is injected to the storage unit. The penalty will be fully or partially hedged.
- 2) *D-H* Available wind power is more than wind farm's obligation. The system needs the additional power, however the owner may observe comparatively higher benefit in storing the additional power and sell it in future hours when the regulation market price is higher. The likelihood of this later decision is specially strengthened as there is no reward in the actions which lead to imbalance mitigation of the overall system. In next section, we will discuss how setting a reward scheme can deal with this issue. The possible emerging problems will be also discussed.
- 3) *S-L* Here the wind farm is generating less than scheduled level which means it is unintentionally alleviating system imbalance condition. On the other hand, storage unit as a part of the facility has the possibility to absorb some of the surplus power of the grid which is the favorable action from system operator's view point. Nevertheless, lack of incentives under the current scheme may cause the storage unit to hold its *free capacity* for the following purposes; mitigating the over generation of the wind farm, participation in downward regulation reserve market, charging the unit in hours with less prices.
- 4) *D-L* The difference (remaining power to meet the scheduled level) is injected by the storage unit. The storage unit may inject power to the grid to alleviate the system imbalance. The penalty is

---

<sup>6</sup>  $\beta$  is a pre-defined penalty (money unit/MWh).

hedged depending on the design parameters, imbalance penalty, and storage benefit from market participation.

Although the market framework used in this study uses the deviation from DAM, penalties in some markets are associated with deviation from the intraday markets. In Nordic market there is no direct penalty for deviation, but in case of any deviation the unit has to buy the regulation power from the market and sell it back to compensate its deviation. For instance if the wind farm bid is 50 MW but it turns out in real time that its actual production is 45 MW, the remaining 5 MW should be bought from the regulation market which is probably more expensive than DAM price [25]. In major US markets the situation is different. In MISO there are no deviation penalties for wind farms. In New York ISO there are no deviation penalties for under-generation. In ERCOT there is a penalty exemption for +/- 50% of scheduled generation. In California ISO, for wind farms which are the participants of the so-called wind program the deviations are netted over monthly average price. Ten minute imbalance penalty is considered for nonparticipants [1].

#### **4.4 Problem Definition**

In this part, mathematical frameworks are maximized to capture the physical fact for aforementioned scenarios under different plausible conditions. It should be noted the proposed model in this study is tied to the power system balancing condition and also on how wind power has materialized in real time (higher or lower than scheduled). The focus here is on modeling the imbalance penalty schemes and to capture on which conditions and for what amount the penalization takes place. For instance in S-H condition the storage has to absorb the extra power because more energy injection to grid deteriorates system surplus condition. Thus the formulation should realize if there is enough free capacity in the battery so that penalty is applied only if the extra produced power exceeds battery's free capacity. But in D-L condition the battery should inject energy to compensate wind power shortage. The penalty will be applied only if the injected energy is less than the shortage from wind power bid (scheduled wind power). In other words, the way the penalty scheme works under different conditions makes it logically impossible to apply the same formulation for all conditions. This point will be further elaborated in next part after formulating the problem.

#### 4.4.1 Time frame of the optimization framework

The wind plant submits its bids to DAM based on wind power forecasts. Also it is assumed that in each hour of the day the WSF has the forecasts for the PSBC of the remaining hours of the day and it is revised hourly. The optimization problem for maximizing the revenue for WSF is solved every hour considering the forecast for wind power and PSBC. Therefore in 24 hours the optimization problem is solved 24 times and each time for the remaining hours of the day (a rolling window). Table II shows a sample of plausible scenarios and the time frame for solving the optimization problems. It can be observed that in hour 1 the time horizon for solving the optimization problem is 24 hours, 12 hours at noon and only 1 hour in the last hour of the day.



Fig. 4. 1 scenarios incorporating wind power realization and PSBC

Depending on the combinations that occur in the optimization horizon, the related revenue maximizing formulation will be used. For instance in Fig. 4. 1, in the first three hours, S-H optimization is solved. If the role of storage unit is to mitigate wind power imbalances (as said in the first approach), the storage unit takes an action in D-L or S-H conditions. There is no need for an action in D-H and S-L conditions as the wind power imbalance enhances PSBC (High wind power is a plus in power system deficit- Low wind power is a plus in power system surplus) and thus there is no penalty as explained in 4.3.

Table III shows the storage action plan in hour 1. As previously mentioned there is no action plan in D-H and S-L scenarios. Table IV shows the storage action plan for hour 12. The forecasted PSBC for a specific hour is updated hourly. For this reason the forecasted PSBC for a specific hour may change from one hour to the other. For instance, at hour 1, the PSBC(1,15)<sup>7</sup> is forecasted to be D-L, however when the forecast is done at hour 12, PSBC(12,15) is forecasted to be S-H.

<sup>7</sup> PSBC(1,15) is power system balancing condition forecasted at hour 1 for hour 15.  
PSBC(12,15) is power system balancing condition forecasted at hour 12 for hour 15.

PLAUSIBLE SCENARIOS FOR EACH OF HOUR OF THE DAY.

Hr. 1	PSBC	S	S	S	D	D	D	D	S	S	S	S	S	S	D	D	D	S	D	D	S	S	S	S	S		
	WP	L	L	H	H	H	H	H	H	H	H	H	L	L	L	L	H	H	L	H	L	L	H	H	H		
Hr. 2	PSBC		S	S	D	D	D	D	S	S	S	S	S	S	S	D	S	D	D	D	D	D	D	S	S		
	WP		L	H	H	H	H	H	H	H	H	L	L	L	L	L	H	H	L	L	L	H	H	L	L		
Hr. 3	PSBC			S	D	D	D	D	S	D	D	D	D	D	D	S	S	D	D	D	S	D	D	D	D		
	WP			H	H	H	H	H	H	L	L	L	L	L	L	L	H	L	H	L	L	H	L	L	L		
...																											
Hr. 12	PSBC															S	S	S	D	D	D	D	D	S	S	S	S
	WP															L	L	H	H	H	H	H	L	H	H	H	H
...																											
Hr. 23	PSBC																									S	D
	WP																									L	L
Hr. 24	PSBC																										D
	WP																										L

STORAGE ACTION PLAN IN HOUR 1.

Hr.	1	2	3	4	5	6	7	8	9	10	11	12
St. Ac.			S-H					S-H	S-H	S-H	S-H	
Hr.	13	14	15	16	17	18	19	20	21	22	23	24
St. Ac.		D-L	D-L		S-H	D-L				S-H	S-H	S-H

STORAGE ACTION PLAN IN HOUR 12.

Hr.	13	14	15	16	17	18	19	20	21	22	23	24
St. Ac.			S-H					D-L	S-H	S-H	S-H	S-H



Having explained this, the optimization formulation which is solved in an hour will maximize the WSF in hours that SU takes an action. The reader should note that here the primary assumption is that SU takes no action in hours with D-H and S-L conditions. For instance the optimization problem which is solved in the first hour maximizes the WSF's revenue for by considering SU operation in the following hours: Hr. 3 (S-H), Hr. 8-11 (S-H), Hr. 14-15 (D-L), Hr. 17 (S-H), Hr. 18 (D-L), Hr. 22-24 (S-H).

Also for the hour 12 the problem will be maximizing WSF's revenue considering SU operation in the following hours: Hr. 15 (S-H), Hr. 20 (D-L), Hr. 21-24 (S-H).

It can be mathematically written as (respectively for hour 1 and 12):

Maximize  $(\sum_3^3 f_{S-H} + \sum_8^{11} f_{S-H} + \sum_{14}^{15} f_{D-L} + \sum_{17}^{17} f_{S-H} + \sum_{18}^{18} f_{D-L} + \sum_{22}^{24} f_{D-L})$ , subject to constraints

Maximize  $(\sum_{15}^{15} f_{S-H} + \sum_{20}^{20} f_{D-L} + \sum_{21}^{24} f_{S-H})$ , subject to constraints

Where  $f_{S-H}, f_{D-L}$  are the revenue maximizing functions and will be introduced in the next section in addition to constraints.

In the next part, we introduce the problem formulation under two approaches; the first approach assumes that the storage unit's sole duty is to mitigate wind power imbalances and second approach considers that storage unit participates in the regulating market in addition to mitigating wind imbalances.

#### 4.4.2 Problem formulation-approach 1

For approach 1 the WSF's revenue under S-H condition is formulated as the following convex optimization framework presented from (4.1) to (4.9), (the objective function is called  $f_{(S-H)}$  in the previous section). The nomenclature is as below:

A. *Decision variables*

$p_i^{s,w}$  Power interaction by storage unit because of wind power fluctuation at hour  $i$

$R_{k,j}^{s,up}$  Upward regulation provided by storage unit at hour  $i$

$R_{k,j}^{s,dn}$  Downward regulation provided by storage unit at hour  $i$

B. *Auxiliary Variables*

$Dev_i$	Wind power deviation from the scheduled level at hour $i$
$Dev_i^{res}$	Wind power deviation from the scheduled level after storage compensation at hour $i$
$s_i$	Storage charge level at hour $i$
$s_i^{res}$	Free residual capacity of storage unit at hour $i$

C. Input data and Constants

$\pi_i^{DAM}$	Day ahead market price at hour $i$
$\pi_i^{RT}$	Real time price at hour $i$
$p_i^w$	Realized wind power at hour $i$
$P_i^w$	Scheduled power for wind farm at hour $i$
$\beta$	Deviation penalty
$ramp\_dn$	Storage unit's downward ramp rate
$ramp\_up$	Storage unit's upward ramp rate
$reward$	Reward for mitigating deviation
$s_{max}$	Battery unit's maximum capacity
$s_{min}$	Battery unit's minimum allowed capacity
$ll$	Lower limit of optimization problem
$ul$	Upper limit of optimization problem

$$\text{Max} \sum_{ll}^{ul} P_i^w \pi_i^{DAM} + Dev_i \pi_i^{RT} - \max\{0, Dev_i^{res}\} \beta \quad (4.1)$$

Subject to:

$$Dev_i = p_i^w - P_i^w - p_i^{s,w} \quad (4.2)$$

$$s_i^{res} = s_{max} - s_i \quad (4.3)$$

$$Dev_i^{res} = Dev_i - s_i^{res} \quad (4.4)$$

$$s_1 = s_1^* \quad (4.5)$$

$$s_{i+1} = s_i + p_i^{s,w} \quad (4.6)$$

$$p_i^{s,w} \geq 0 \quad (4.7)$$

$$s_i + p_i^{s,w} \leq s_{\max} \quad (4.8)$$

$$p_i^{s,w} \leq p^{s,max} \quad (4.9)$$

The objective function to be maximized is the revenue from imbalance settlement in real time market (second term) minus possible imbalance penalties (see Table I). It should be noted that the first term ( $P_i^w \pi_i^{DAM}$ ) in the objective function (4.1) is constant as Day-ahead market is already cleared. Thus it has no effect on problem optimal values (added for easier understanding). Second term ( $Dev_i \pi_i^{RT}$ ) gives the imbalance settlement after storage interaction. Finally third term ( $\max\{0, Dev_i^{res}\} \text{penalty}$ ) gives the imbalance penalty. It should be noted that the term *real time market* can be replaced by *regulation or balancing market* in different electricity markets.

In (4.2) the deviation value after storage compensation is given. Equation (4.3) gives the free capacity of the storage unit (the efficiency of battery unit is assumed 100%). Equation (4.4) gives the deviation which has still remained after storage compensation. Initial energy of storage unit is introduced in (4.5). Next the relationship of state of the charge between two consecutive hours is given in (4.6). Equations (4.7) and (4.8) guarantee that state of the charge of the battery is within allowed limits in all hours. It is ensured in (4.9) that the maximum allowed power of the storage unit's inverter is not violated. Storage unit's ramp rate constraint is not included here as it is usually much faster than the average wind fluctuation within an hour. However it can be added without having an impact on optimization outcome.

To get a more intuitive insight to the problem a numerical example is given here. Assume that the wind power bid at hour  $i$  is 1 MW ( $P_i^w = 1$ ), the realized wind power is 1.3 MW ( $p_i^w = 1.3 \text{ MW}$ ), the battery's energy level  $s_i = 1.7 \text{ MWh}$  and maximum allowed energy for battery  $s_{\max} = 1.8 \text{ MWh}$ . Then according to (4.2), we will have  $Dev_i = 0.3 - p_i^{s,w}$  and according to (4.3) we will have  $s_i^{res} = 0.1 \text{ MWh}$ . Considering (4.4) gives the wind power imbalance after compensation as  $Dev_i^{res} = 0.2 - p_i^{s,w}$ . The term  $\max\{0, Dev_i^{res}\} * \text{penalty}$  in the objective function indicates that  $p_i^{s,w}$  should be higher than 0.2 to avoid penalty term to be effective. In simple words, (4.3) gives the residual (free) capacity of the battery and (4.4) indicates how much of extra wind power can be absorbed by the residual (free) capacity.

The formulation for D-L condition is written as: (the objective function is called  $f_{D-L}$  in the previous section)

$$Max \sum_{ll}^{ul} P_i^w \pi_i^{DAM} + Dev_i \pi_i^{RT} + \min\{0, Dev_i\} \beta \quad (4.10)$$

*Subject to:*

$$Dev_i = p_i^w - P_i^w + p_i^{s,w} \quad (4.11)$$

$$s_1 = s_1^*, \quad s_{i+1} = s_i - p_i^{s,w} \quad (4.12)$$

$$s_i - p_i^{s,w} \geq s_{min} \quad (4.13)$$

$$p_i^{s,w} \leq p^{s,max} \quad (4.14)$$

$$p_i^{s,w} \geq 0 \quad (4.15)$$

Here we can emphasize on the reason for introducing two different problem formulations. The reason should be noticed in the third term of the objective function which gives the penalty. In S-H condition for instance, the wind-storage facility will be penalized only if the remained free capacity in the battery is not large enough for absorbing the extra wind power<sup>8</sup>. This makes us to define an auxiliary variable for having the free (residual) capacity in the battery (named  $Dev_i^{res}$  in the problem formulation). But in D-L condition, there is no need for this auxiliary variable and wind-storage facility will be penalized only if the already stored energy in the battery is not enough to compensate the wind power shortage. In this condition the imbalance is compensated by the stored energy in the battery (as shown with  $Dev_i$ ). In addition, unlike S-H condition, in D-L condition there is no need for defining an auxiliary variable for free residual state of the charge ( $s_i^{res}$ ).

Also there is no need for the battery to take an action in S-L and D-H conditions. Considering the mentioned facts, these conditions cannot be modeled together in the same optimization framework. Considering the presented formulations, the solution for finding the optimal operation is shown in Fig.4.2 and Fig.4.3.

---

<sup>8</sup> One may argue that wind farm may not have to generate the higher power than scheduled so as to attract a penalty, for example, reduce the wind power production by controlling the pitch angle, however in this study the focus is on using the storage unit capabilities rather than control functions of the wind turbines.

The solution follows one of the following techniques:

1. Sequentially solve the sub-problems for each *time range* (determined by  $ll$ ; lower limit-  $ul$ ; upper limit), and keeping the state of the charge of the last hour of *previous* time range and use it as state of the charge of the first hour of the *next* time range. For instance, in our example about hour 12, the S-H formulation is solved at hour 15. As there is no battery operation between 16 and 19, the state of the charge of the battery is used for hour 20 when D-L formulation is solved. The SOC is then passed to hour 21 when S-H formulation is solved for the time range from 21 to 24. In this technique, independent optimization problems are solved sequentially.
2. In second technique, all sub problems are solved together at once. This is possible by considering the SOC<sup>9</sup> of boundary hours as a coupling variable and implementing one of the known decomposition techniques [26]. Boundary hours are when a jump occurs between two time ranges. For instance, the boundary hours are 15, 20, 21 which makes  $s(15)$ ,  $s(20)$ ,  $s(21)$  as coupling variable which should be used in the decomposition technique.

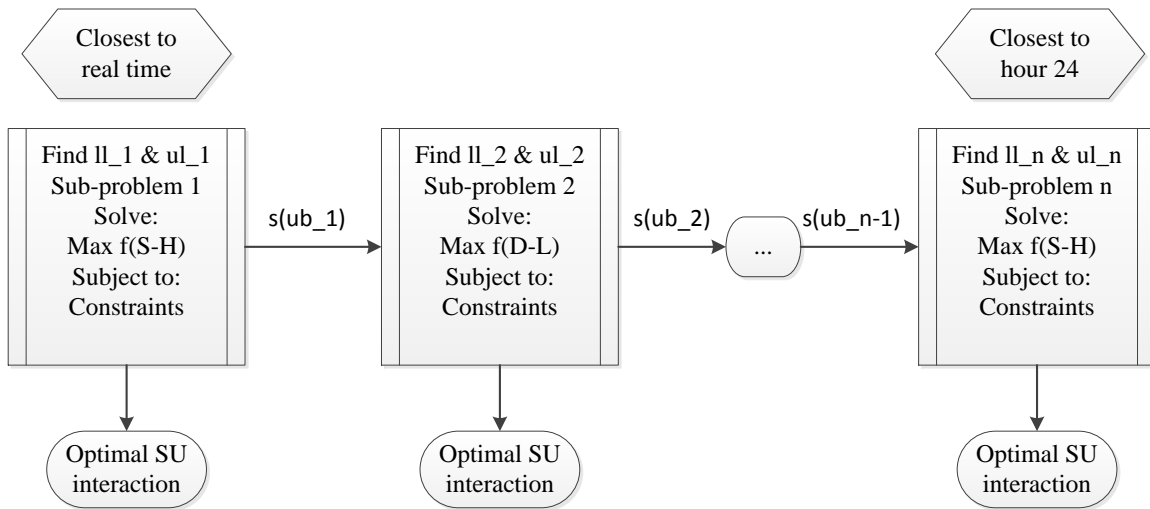

Fig. 4. 2 Maximization of WSF revenue sequentially

<sup>9</sup> or power interaction of storage unit.

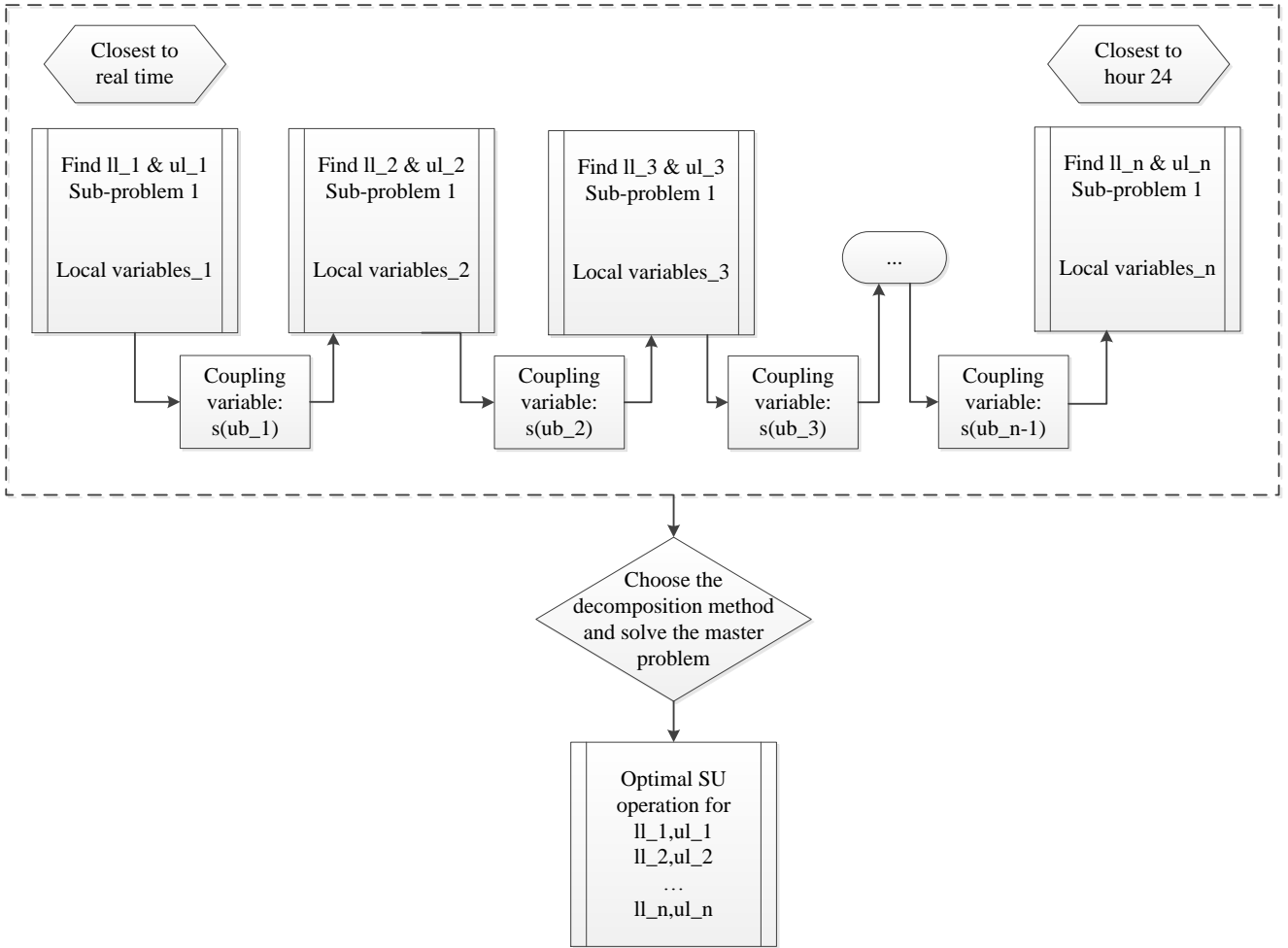

Fig. 4. 3 Revenue maximization using decomposition techniques

These two techniques shall be compared in terms of optimality and computational burden. The first technique gives the propriety to time ranges that are closer to real time operation of power system as it solves the sub-problems chronologically (first sub-problem is solved first, second is solved second and so on). The sequential manner of this technique may bring sub-optimality issues. The second technique solves the *master problem* at once considering the battery's SOC as the coupling variable. The complexity and computational burden is certainly higher in this technique. In this study, the sequential technique is implemented. As mentioned in section 4.4.1 the SU scheduling is done hourly, thus the optimal SU schedules is updated considering hourly wind speed forecast and PSBC updates. Thus SU operates in the immediate coming hour based on the most recent updated schedule. This will reduce the impact of possibly wrong forecasts as forecasts are more precise when they are close to operation time. The first technique is also easier to implement, less complex and has less computational burden.

### 4.4.3 Simulation Results-approach 1

In order to show the functionality of the proposed methodology, two cases are investigated in this section.

#### A. Case I

First the data for a normal day in Denmark in winter 2013 is considered. The wind power production and price, hourly price and deficit/surplus conditions data are taken from Energinet.dk website (Danish Transmission System Operator). Wind power production is scaled down to be usable as a 10 MW wind farm. Also the battery capacity is considered 2 MWh. As there was no access to wind farm bids, we have chosen them arbitrary however typical forecast errors are respected. According to the employed data, each time range lasts for 6 hours; 6 consecutive hours for S-H conditions and another 6 consecutive hours for D-L conditions. Table V shows the storage action plan for the used data.

STORAGE ACTION PLAN FOR THE USED DATA IN HOUR 1.

Hr.	1	2	3	4	5	6	7	8	9	10	11	12
St. Ac.	S-H	S-H	S-H	S-H	S-H	S-H						
Hr.	13	14	15	16	17	18	19	20	21	22	23	24
St. Ac.							D-L	D-L	D-L	D-L	D-L	D-L

Fig. 4. 4 shows the deviation of wind power realization from day ahead submitted bids (first subplot). In subplot 2 the day-ahead market price, real time price which is for every 15 minutes and its hourly average price is shown. The realized wind power is more than submitted bid in this condition (H or higher than scheduled). Also the real time price is lower than day-ahead market price (which happens in surplus conditions). This is recognized as S-H condition and the related problem formulation is solved. The optimal battery operation is determined. Fig. 4. 5 shows the battery's state of the charge with three different initial values (the optimization problem is solved three times each with a different initial value). It can be seen that the battery absorbs the extra wind power, however when it is already charged near its upper limit the storage cannot absorb as much power as it could when the its energy level is low. It is worth mentioning that although the battery

capacity is 2 MWh, however lower and upper limits for battery's capacity is set to 0.2 MWh and 1.8 MWh respectively to avoid depreciation.

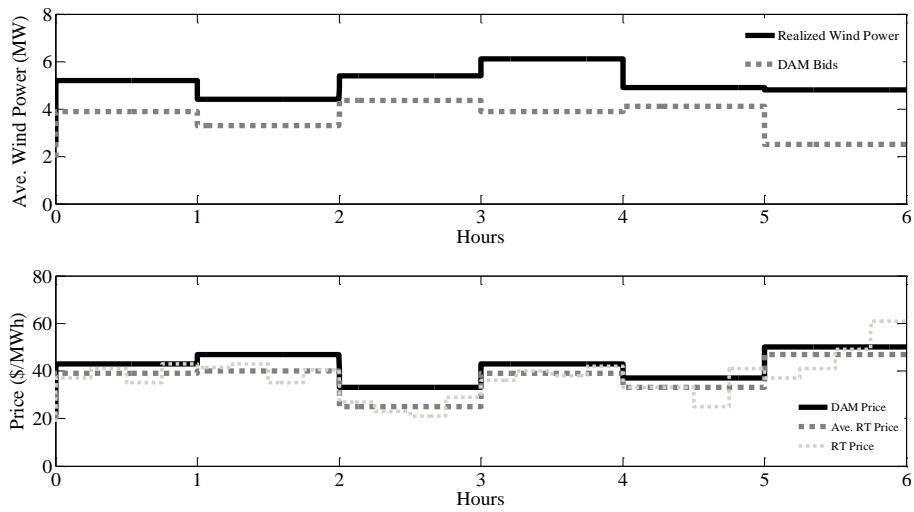

Fig. 4. 4 Wind and Price S-H condition (hour 1 to hour 6)

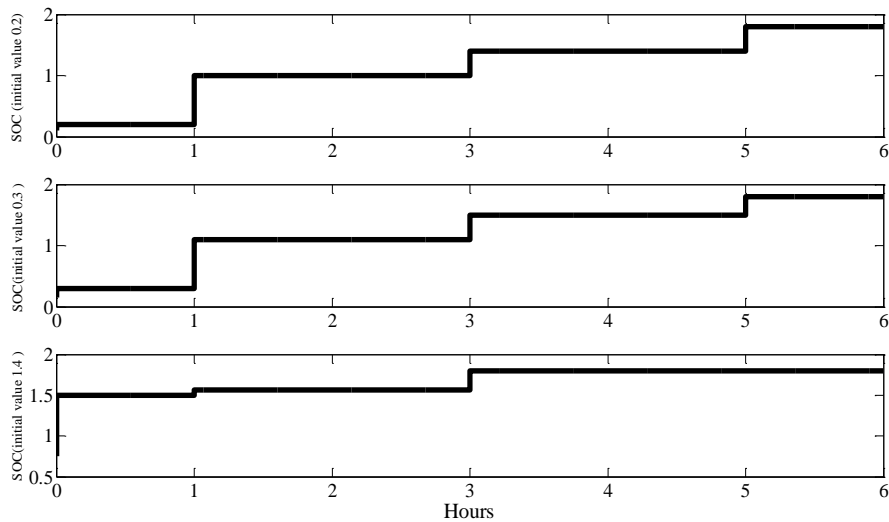

Fig. 4. 5 State of the charge S-H condition (hour 1 to hour 6)

Fig. 4.6 depicts the realized wind power and the market price. The realized wind power is less than the day-ahead submitted bid (L or lower than scheduled). Also, the price is higher in real time (which happens in deficit conditions).

Fig. 4.7 shows the state of the charge with three different initial values. The height of the steps in this figure shows the accumulated power given out in real time to mitigate imbalance penalty in each hour. Average real time price is considered in the presented problem formulation.



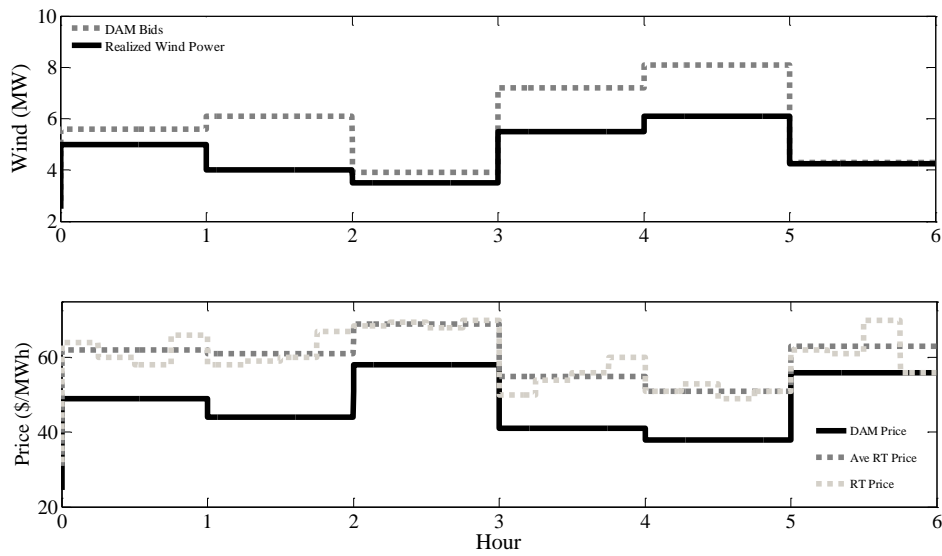

Fig. 4. 6 Wind and Price D-L condition (hour 18 to hour 24)

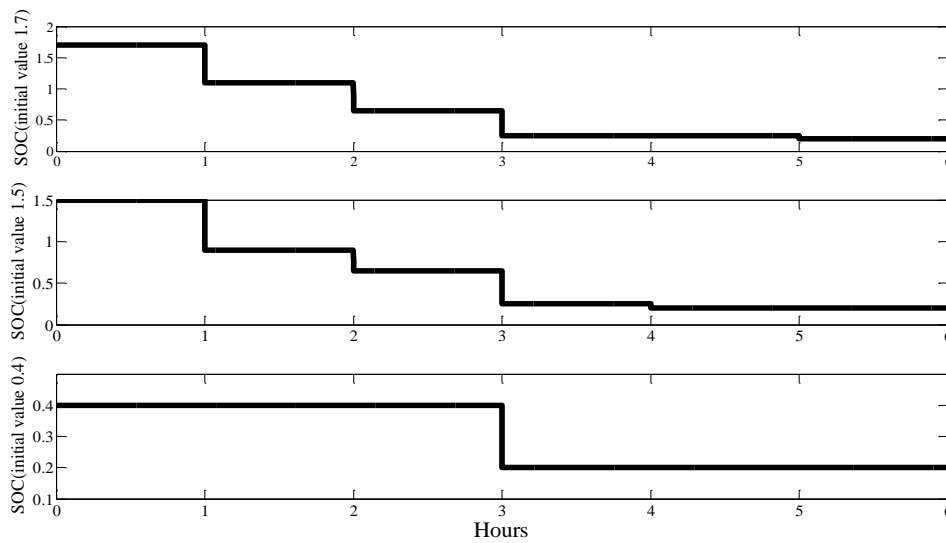

Fig. 4. 7 State of the charge D-L condition (hour 18 to hour 24)

### B. Case II

Having observed the optimal operation of battery unit from Fig 4.4 to Fig. 4.7, the investigation of optimal battery operation is also investigated considering table II and III gives a more intuitive insight. Fig 4.8 shows the optimal injection and absorption of SU for hour 1 (of given example in 4.4.1). SOC consequently changes with storage interaction which is given in the second subplot. The initial state of the charge is assumed 1 MWh. As expected, the SU operates in D-L and S-H

conditions and its interaction is zero in the other two conditions. The positive values in the first subplot represents absorbing power (in S-H condition) and negative values represent injection of power (in D-L condition). Fig 4.9 shows the optimal injection and absorption of SU in addition to SOC for hour 12 of given example in 4.4.1. As it can be seen in the Table II, there are all 4 plausible PSBC. It should be noted that the upper level for SU's SOC is limited to 1.8 MWh to avoid depreciation. That is the reason that SOC remains limited to 1.8 MWh in this figure.

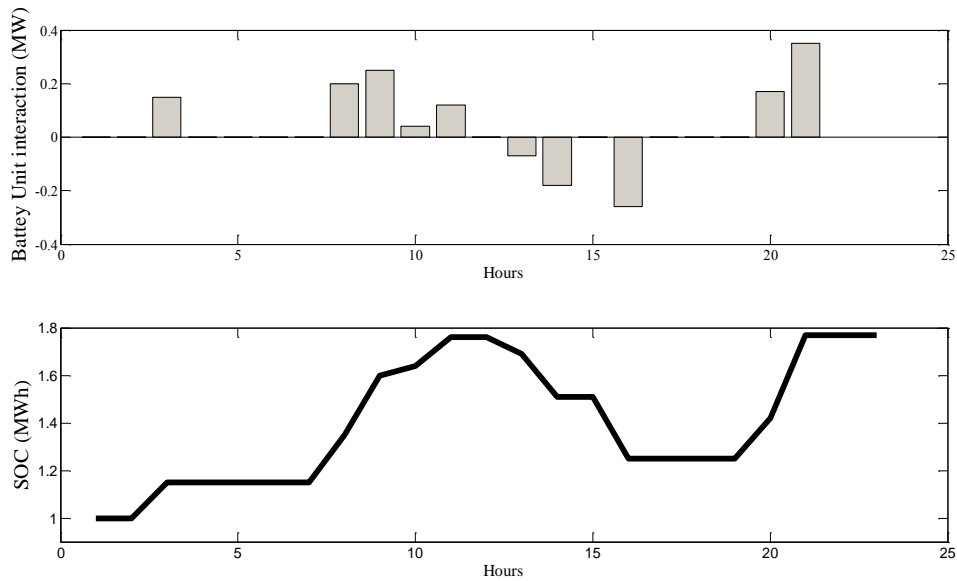

Fig. 4. 8 Battery interaction and SOC- hour 1

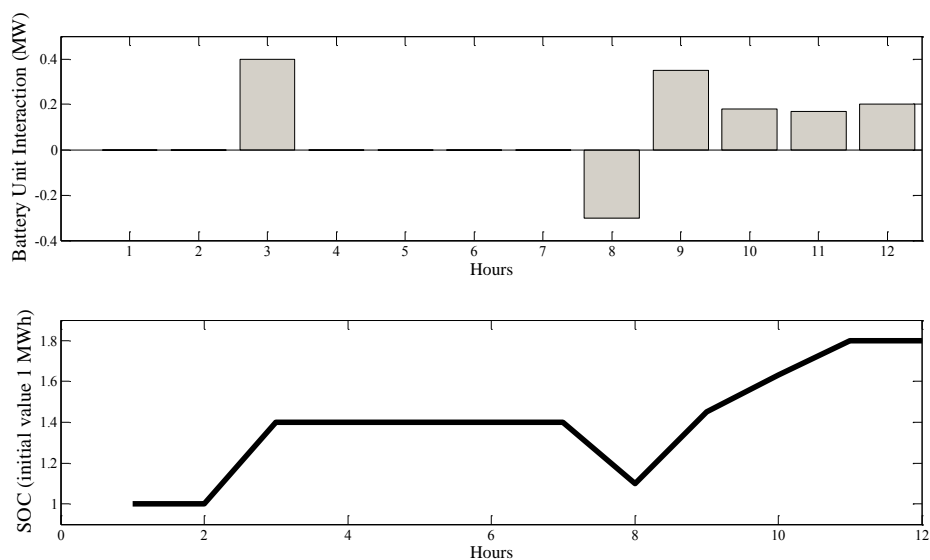

Fig. 4. 9 Battery interaction and SOC- hour 12

#### 4.4.4 Problem formulation -approach 2

In this section the storage unit has the possibility to participate in the real time (balancing-regulation) market. This is formulated as a maximization problem in which the objective function is the sum of revenue from imbalance settlement (second term) and participation in real time market (third term) minus possible imbalance penalties. It should be noted again that the first term ( $P_i^w \pi_i^{DAM}$ ) in the objective function is constant as Day-ahead market is already cleared. Presented formulation captures conditions when wind farm deviations are in the same direction with system balance overall statuses. This is when interaction with storage unit is needed. Below is the formulation for S-H condition. The variable  $R_i^{s,dn}$  is the average of regulation power in hour  $i$ .

$$Max \sum_u^{ul} P_i^w \pi_i^{DAM} + Dev_i \pi_i^{RT} + R_i^{s,dn} \pi_i^{RT} - \max\{0, Dev_i^{res}\} \beta \quad (4.16)$$

*Subject to:*

$$Dev_i = p_i^w - P_i^w - p_i^{s,w} \quad (4.17)$$

$$s_i^{res} = s^{max} - s_i \quad (4.18)$$

$$* : Dev_i^{res} = Dev_i - s_i^{res} \quad (4.19)$$

$$s_1 = s_1^*, s_{i+1} = s_i + p_i^{s,w} + R_i^{s,dn} \quad (4.20)$$

$$s_i + p_i^{s,w} + R_i^{s,dn} \leq s_{max} \quad (4.21)$$

$$s_{max} \geq 0 \quad (4.22)$$

$$p_i^{s,w} + R_i^{s,dn} \leq p^{s,max} \quad (4.23)$$

$$p_i^{s,w} + R_i^{s,dn} - p_{i-1}^{s,w} - R_{i-1}^{s,dn} \leq ramp\_up \quad (4.24)$$

$$p_i^{s,w} + R_i^{s,dn} - p_{i-1}^{s,w} - R_{i-1}^{s,dn} \geq ramp\_down \quad (4.25)$$

Constraint (4.17) gives the wind power deviation considering storage interaction. Constraint (4.18) gives the residual (free) capacity of battery. Constraint (4.19) gives the uncleared imbalance after storage interaction (which should be penalized). Constraint (4.20) determines the relationship between SOC in two consecutive hours considering SU interaction for imbalance mitigation ( $p_i^{s,w}$ ) and participating in real time market ( $R_i^{s,dn}$ ). Constraints (4.21) and (4.22) guarantee that state of

the charge of the battery is within allowed limits in all hours. It is ensured in (4.23) that the maximum allowed power of the storage unit's inverter is not violated. Constraints (4.24) and (4.25) guarantee that ramp rates are not violated. The constraints are linear. The objective function can be also converted to two linear functions which make it possible to solve the problem with linear programming. As this is a convex optimization problem we solve it in previously introduced optimization package CVX.

Same formulation with few modifications captures D-L condition. In the formulation covering S-H condition, the main concern in the third constraint (identified by star) is to ensure that the remaining free capacity of the storage unit can fully absorb the excessive power from the scheduled level. Nevertheless in this part the main concern is that the stored energy in the battery can compensate under generation of the wind farm. For formulating D-L condition, few modification should take place, for instance (4.19) and (4.20) should replace (4.26) and (4.27). Also the penalizing term in the objective function is changed accordingly.

$$Dev_i = p_i^w - P_i^w + p_i^{s,w} \quad (4.26)$$

$$s_{i+1} = s_i - p_i^{s,w} - R_i^{s,up} \quad (4.27)$$

#### 4.4.5 Simulation Results-approach 2

Implementing the problem formulation for the second approach, the SU has the possibility to independently participate in the regulation market. We run the optimization framework for the first hour of the day to get the optimal battery unit interaction for a whole day. PSBC is used as shown in table II. Fig. 4. 10 shows the interaction of battery unit and also the state of the charge under three different values for imbalance penalties.

The first row shows the results for high level of penalty; it can be seen that the battery interaction is exactly the same with results shown for the first approach (Fig.4.8). High imbalance penalty forces the battery unit to fully dedicate SOC for mitigating wind power imbalances. In the second row, the penalty value is considered to be medium range. It can be seen that battery operation is not limited to D-L and S-H conditions anymore and there it also operates in hours that SU was idel under high values for imbalance penalty (under the first approach). The battery unit interaction remains almost same under high and medium penalty levels and so does the SOC curve. In the third row which the

optimization problem is run under low imbalance penalty, battery interaction is totally different. In this scenario, the battery unit is willing to sacrifice its role for imbalance mitigation, for gaining higher revenue in regulation market.

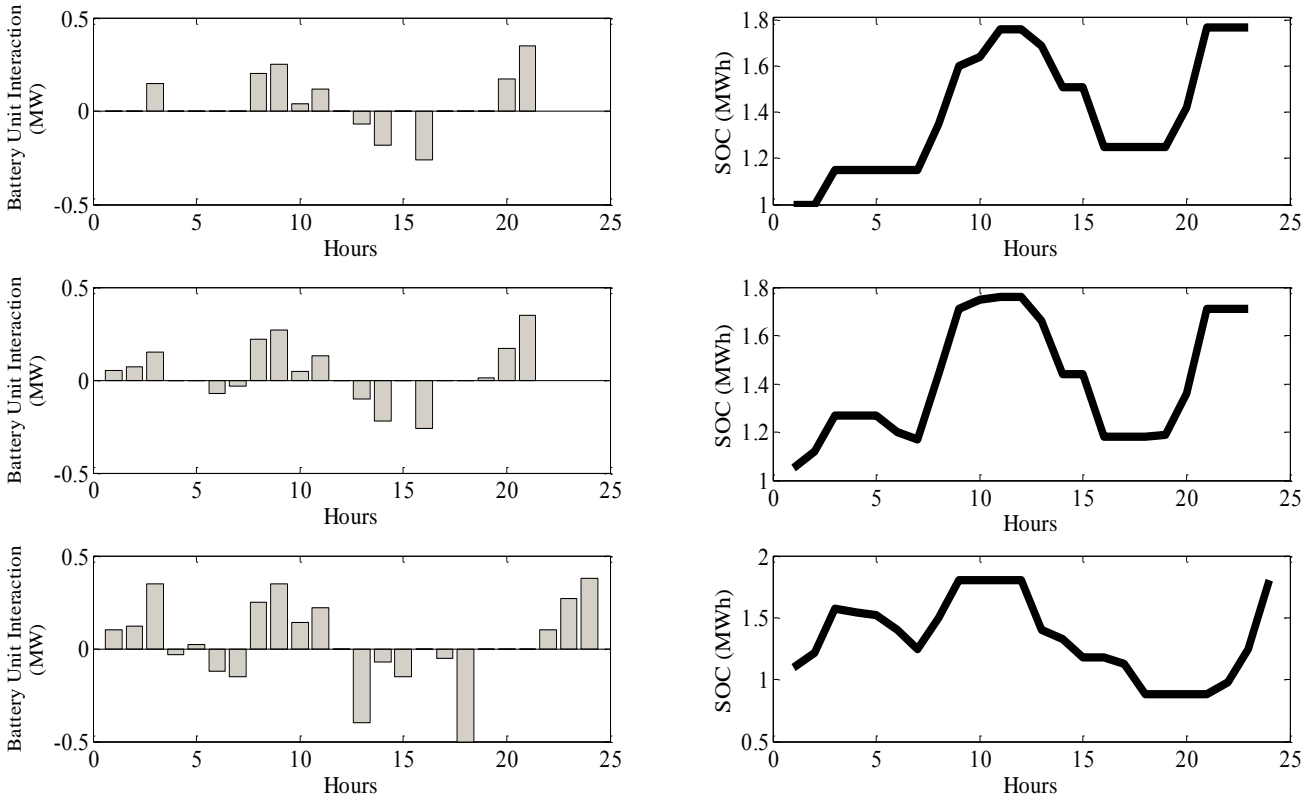

Fig. 4. 10 Battery interaction under 3 values for imbalance penalties- hour 1

The comparison of third row with first and second row shows the trade-off between mitigating wind power imbalances from one side and making additional revenue in regulation market on the other side. Under low imbalance penalty scheme, the battery unit freely participates in the regulation market and the commitment for mitigating wind imbalances is decreased.

#### 4.5 Discussion

In this study two approaches are presented to formulate cooperative optimal operation of wind-storage facilities. A penalty scheme is assumed to be in place to encourage wind power units to implement precise forecast techniques. This is penalty only scheme. A penalty-reward scheme can

be also studied where the wind farm is rewarded due to deviation in the opposite direction of system balance status. These imbalances unintentionally alleviate the PSBC.

To dig into this topic, following statement can be investigated; *Generators who cause the imbalance should be penalized while those who mitigate the system imbalance should be rewarded.* We have conducted such a study and the primary results show that wind farms which are facilitated by storage units may face a conflict of interest (between their own benefit and alleviating power system imbalances). This is due to storing possibility of the combined wind-storage facility (in comparison to a single standing wind farm). In addition, a strong argument that supports penalty-only scheme is that it avoids market distortion. If an energy producer knew in advance that, during imbalance periods they could earn more money if up-regulation were needed, it creates a financial incentive to distort their actual day-ahead bids. The penalty-only structure does not provide such an incentive. In addition, *second guessing* the system operator can bring significant issues. If the frequency is low<sup>10</sup> and resources are incentivized to over generate without recognition the level of over generation, over frequency issues can be expected. Another example is that a unit that is over generating during low frequency periods (with negative Area Control Error-ACE) may excessively overload a transmission line. More detailed issues that may arise due to resource's second guessing is addressed in the FERC Order 755. FERC indicates that resources are remunerated based on how well they follow the system operator control signal, and not on how well they improve ACE. This is simply to avoid potential manipulation of balancing parties. The earlier version of this work is available at [26].

#### **4.6 Summary**

In this chapter a wind farm uses storage unit to mitigate wind power imbalances. Having an operations research perspective, optimal operation of storage unit is investigated for two different functions. First it is assumed that the storage sole responsibility is to mitigate wind power imbalances. Then the storage unit is given the possibility to participate in balancing market. Wind-Storage facility maximizes its revenue by total or partial mitigation of imbalance penalties and also participation in balancing markets.

---

<sup>10</sup> For readers with backgrounds other than power systems: when power system is in deficit conditions, the grid frequency is lower than the nominal frequency. When power system is in surplus conditions, the grid frequency is higher than the nominal frequency.

Physical limits of the storage system form the constraints of the optimization problem. The model used in this study considers power system balancing conditions in addition to wind power realization condition. Considering the impact of power system balancing needs on optimal operation of storage unit is investigated under different scenarios. The uncertainty of wind power and load are dealt by a rolling window in which the forecasts for wind power and system balancing condition are hourly updated. The optimal interaction of storage units are compared and discussed in both scenarios. The optimization framework can be used by wind farms which are facilitated to battery unit for enhanced economic viability.

### References:

- [1] Audun Botterud, Jianhui Wang, V. Miranda, Ricardo J. Bessa, "Wind Power Forecasting in U.S. Electricity Markets", Argonne National Laboratory, USA, University of Porto, Portugal, Sep. 2010.
- [2] Richard Scharff, Mikael Amelin, Lennart Söder, "Approaching wind power forecast deviations with internal ex-ante self-balancing, " *Energy*, Volume 57, pp. 106-115, Aug. 2013.
- [3] H.M.I. Pousinho, V.M.F. Mendes, J.P.S. Catalão, "A risk-averse optimization model for trading wind energy in a market environment under uncertainty, " *Energy*, Vol. 36, Issue 8, pp. 4935-4942, Aug. 2011.
- [4] Gong Li, Jing Shi, "Agent-based modeling for trading wind power with uncertainty in the day-ahead wholesale electricity markets of single-sided auctions, " *Applied Energy*, Vol. 99, pp. 13-22, Nov. 2012.
- [5] Venkat Krishnan, Trishna Das, James D. McCalley, "Impact of short-term storage on frequency response under increasing wind penetration, " *Journal of Power Sources*, Vol. 257, pp. 111-119, Jul. 2014.
- [6] Burak Turker, Sebastian Arroyo Klein, Lidiya Komsiyyska, Juan José Trujillo, Lueder von Bremen, Martin Kühn, Matthias Busse, "Utilizing a vanadium redox flow battery to avoid wind power deviation penalties in an electricity market, " *Energy Conversion and Management*, Vol. 76, pp. 1150-1157, Dec. 2013.
- [7] Banham-Hall, D. Taylor, G.A., "Frequency control using Vanadium redox flow batteries on wind farms, " *Power and Energy Society General Meeting, 2011 IEEE* , pp.1,8,24-29.

- [8] José Pablo Chaves-Ávila, Rudi A. Hakvoort, "Short-term strategies for Dutch wind power producers to reduce imbalance costs, " *Energy Policy*, Vol. 52, pp 573-582, Jan. 2013.
- [9] Akhavan-Hejazi, H. Mohsenian-Rad, H., "Optimal Operation of Independent Storage Systems in Energy and Reserve Markets With High Wind Penetration," *IEEE Trans. Smart Grid*, vol.5, no.2, pp.1088,1097, March 2014.
- [10] Ghofrani, M. Arabali, M. Etezadi-Amoli, M. Fadali, "Energy Storage Application for Performance Enhancement of Wind Integration," *IEEE Trans. Power Systems*, vol.28, no.4, pp.4803,4811, Nov. 2013.
- [11] Khodayar, M.E, Shahidehpour, M., "Stochastic Price-Based Coordination of Intrahour Wind Energy and Storage in a Generation Company," *IEEE Trans. Sustainable Energy*, vol.4, no.3, pp.554,562, Jul. 2013.
- [12] Haoran Zhao, Qiuwei Wu, Shuju Hu, Honghua Xu, Claus Nygaard Rasmussen, "Review of energy storage system for wind power integration support, " *Applied Energy*, 2014.
- [13] Eric Hittinger, J.F. Whitacre, Jay Apt, "What properties of grid energy storage are most valuable?, " *Journal of Power Sources*, Vol. 206. 15, pp. 436-449, May 2012.
- [14] Kiran Kumaraswamy, Jamie Cotrone, "Evaluating the Regulation Market Maturity for Energy Storage Devices, " *Electricity Journal*, Vol. 26, Issue 10, pp. 75-83, Dec. 2013.
- [15] Khoi Vu, Masiello, R., Fioravanti, R., "Benefits of fast-response storage devices for system regulation in ISO markets," *2009 Power & Energy Society General Meeting*, pp. 1-8.
- [16] Weihao Hu, Zhe Chen. Bak-Jensen, B., "Optimal operation strategy of battery energy storage system to real-time electricity price in Denmark," *2010 Power and Energy Society General Meeting, 2010 IEEE*, pp. 1-7.
- [17] Pillai, J.R.; Bak-Jensen, B., "Integration of Vehicle-to-Grid in the Western Danish Power System," *Sustainable Energy, IEEE Trans. on*, vol.2, no.1, pp.12,19, Jan. 2011.
- [18] Abdul Motin Howlader, Yuya Izumi, Akie Uehara, Naomitsu Urasaki, Tomonobu Senjyu, Atsushi Yona, Ahmed Yousuf Saber, "A minimal order observer based frequency control



strategy for an integrated wind-battery-diesel power system, " *Energy*, Volume 46, Issue 1, pp 168-178, Oct. 2012.

[19] M. Khalid, A.V. Savkin, "An optimal operation of wind energy storage system for frequency control based on model predictive control, " *Renewable Energy*, Volume 48, pp. 127-132, Dec. 2012.

[20] Benjamin Biegel, Mikkel Westenholtz, Lars Henrik Hansen, Jakob Stoustrup, Palle Andersen, Silas Harbo, "Integration of flexible consumers in the ancillary service markets, " *Energy*, Vol. 67, pp. 479-489, Apr. 2014.

[21] Tarjei Kristiansen, "The Nordic approach to market-based provision of ancillary services, " *Energy Policy*, Vol. 35, Issue 7, pp. 3681-3700, July 2007.

[22] Brendan Kirby, Michael Milligan, "An Examination of Capacity and Ramping Impacts of Wind Energy on Power Systems, " *The Electricity Journal*, Vol. 21, Issue 7, pp. 30-42, Aug 2008.

[23] Alberto J. Lamadrid, Tim Mount, "Ancillary services in systems with high penetrations of renewable energy sources, " the case of ramping, *Energy Economics*, Vol. 34, Issue 6, pp. 1959-1971, Nov. 2012.

[24] Beibei Wang, Benjamin F. Hobbs, "A flexible ramping product: Can it help real-time dispatch markets approach the stochastic dispatch ideal?, " *Electric Power Systems Research*, Vol. 109, pp. 128-140, Apr. 2014.

[25] Energinet.dk (Denmark ISO), Regulation "C2: The balancing market and balancing settlement, Revision 2," Fredricia, Denmark.

[26] Stephen Boyd, Lin Xiao, Almir Mutapcic, and Jacob Mattingley, Notes on Decomposition Methods, Notes for EE364B, Stanford University, Winter 2006-07.

[27] Mostafa F. Astaneh, Weihao Hu, Zhe Chen, "Cooperative Optimal Operation of Wind-Storage Facilities, " Proceedings of the 6th *IEEE PES Asia-Pacific Power and Energy Engineering Conf.*, APPEEC 2014. IEEE Press, 2014.

## Chapter 5

### Enhanced Demand Responsiveness

#### 5.1 Demand Response, a flexibility resource

Besides having many advantages, renewables are hard to predict and thus scheduling the generation sources is a challenging task in power systems with significant renewable sources. This challenge can be addressed by introducing new flexibility sources to the electric energy system. In this regard, demand side flexibility plays a crucial role. However since the emergence of power systems, demand has always played a passive role. This passiveness is generally originated by insufficient price incentives. This can be interpreted as the lack of price difference in peak and off-peak hours. The key idea of this study is to improve the demand side activeness by optimally increasing the financial incentives for consumers to participate more efficiently in so-called Demand Response (DR) programs. The proposed scheme is a set of algorithms that optimally converts the original price set to a new set by which DR is systematically encouraged. However several considerations should be taken into account before any sort of price modification can take place. Real data from Danish power system is used to verify the functionality of the proposed model. The results indicate that optimal pricing can increase price responsiveness and successfully shift the load from peak to off-peak hours.

#### 5.2 Introduction and literature review

Denmark will have 50% of electricity consumption from wind energy by 2020 and plans to be independent of fossil fuels by 2050 [1]. In such a network, it is very important to have enhanced flexibility levels in both supply and demand sides. During the last two decades most of the research activities have focused on the supply side and little attention has been paid to releasing demand side potentials. As a result the demand side elasticity is too small and a large portion of the electric load is not price sensitive [2]. Thus real time price signals are not encouraging enough to change consumer's behavior. Although many reports have indicated high peak shaving potentials for Demand Respond (DR) initiatives (up to 25% of peak load), real world practices show that DR initiatives could only reduce power peak values as small as only 2.9% in Europe and 5% in US [3].

This unresponsiveness will jeopardize power system security in scarcity conditions, for instance low speed wind scenarios in wind dominant power systems such as Denmark. The load elasticity is too small in today's electricity market. This is because the electricity has been traditionally a public subsidized state service and consumers have a passive shopping behavior when it comes to electricity (instead of an active shopping role). Beside this main reason there are a couple of more reasons for inelastic prices of electricity. *Low potential saving:* The monthly bill is just a small portion of total family income. According to the Bureau of Labor Statistics, in 2009 electricity expenditures averaged 2.8% of total income in the U.S. A smart grid demonstration project in the Danish island of Bornholm indicates consumer's weak willingness to change their consumption behavior even though they had access to real time price signals. *Small price difference in peak and off-peak:* In the so-called DAM, the price difference between power scarcity and surplus condition is not high enough to encourage DR. *Response fatigue:* Constant change in real time electricity price discourages DR as consumers have to program the function of their appliances accordingly. This leads to a phenomena called response fatigue [2].

The goal of this chapter is to optimally (and systematically) modify hourly electricity price for load shifting and reduce power system stress conditions. This will be done by Demand Response Aggressor (DRA). This will transform the act of electricity purchasing from a passive to an active form. However there are some considerations which should be carefully noticed. Some of these considerations are:

- Any price modification should be administratively controlled
- The consumers should be informed about any deviation from market price
- The new scheme is only an option and only consumers who are willing to participate in the plan will be subjected to change prices
- DRA offers this option to its consumers; however the terms of the contract should be proven by system operator (TSO or DSO)
- The average of original price set should be same with that of modified price set

In the next section the problem will be mathematically formulated. To the best of our knowledge this idea for peak shaving is quite novel, and that is the author's motivation for filling the literature gap in this area. Nevertheless the literature is quite rich when it comes to analyzing the benefits of demand response programs. Field surveys [4]-[6] indicate the importance of devoting more research efforts to enhancing demand side role in future smart grid. These studies show that only a few

percentage of the load potential is used by DR programs. Researchers in [7] – [8] investigate the usefulness of having responsive loads for power system security. In [9] the impact of demand responsiveness on system reliability indices such as Loss of Load Probability (LOLP) is given. It is investigated that DR improves system reliability indices to a great extent.

This chapter assumes that the price modification is done by demand response aggregators. The role of these entities is explained in [10] in detail. In [11] aggregated load participation in balancing markets is investigated. Authors focus on European balancing markets, particularly in Germany. Considering that industrial loads form a considerable part of the total electricity demand in Europe (36.1% of total electricity consumption) and also easier controllability of industrial loads due to high *consumption per customer index*, authors study the benefits of aggregated load participation of industrial loads in balancing markets.

Similar to DRA, electricity retailers are intermediary companies which buy electricity from wholesale market and resell it to consumers. Considering this role, a reward-based DR is mathematically formulated in [12] where the unpredictable behavior of costumers participating in this DR program is modeled by defining probabilistic scenarios. In [13] a model is proposed to include demand response in wind offering strategy. In this model the wind power has the possibility to trade DR with DRA. It is concluded that cooperation with DRA, increases the financial gain of wind farm due to decreasing forecast errors.

One of the most important factors in demand response studies is considering the load elasticity. The way the elasticity is modeled affects the results of the study. Empirical studies are needed to gain the elasticity function of electricity. It can be affected by the type of load, average income of the consumer, availability of substitute sources and many other different factors. In [14] the electricity consumption data of 30,000 household in India is gathered in a data survey. Three electricity demand functions are econometrically estimated using the monthly data for different seasons and weather patterns. Similar study is done in [15] for determining demand elasticity in China. The elasticity absolute value in industrial, commercial, agricultural and residential sectors is calculated. In [16] statistical analysis of load patterns and Symmetric Generalized McFadden cost function model are used to estimate the demand responsiveness of 20 largest industrial energy consumers in Houston area to wholesale price signals in the restructured Electric Council of Texas (ERCOT) model. Based on the data of 2003, the authors conclude that mentioned large industrial complexes cannot yet be relied on for providing the grid critical peak demand calls. Based on the data for

2002-2006 for 22 cities in Switzerland, two log–log demand equations for peak and off-peak electricity consumption using static and dynamic partial adjustment approaches is estimated in [17]. The attempt of this empirical analysis has been to highlight some of the characteristics of the Swiss residential electricity demand. Result indicates that peak and off-peak electricity are substitutes. It is shown that, time differentiated prices should be incentivizing enough to provide an economic incentive to customers so that they modify their consumption patterns. In [18] three different ways are introduced to foster economic DR in the Midwest ISO, USA. These include, first, an approach in which retail customers are moved to dynamic pricing and other time-based pricing rates; second, an approach in which these same entities and possibly third-parties bid price responsive demand curves into the wholesale market; and third, an approach in which demand response is bid as a supply resource into the wholesale market. In [19], a novel decision model for contract options based on activity-based costing and stochastic programming is developed to evaluate the load curtailment options. The target consumption sector here is industrial customers.

The utility company sets contracts to industrial customers in which customers can be called up to reduce their consumption in certain hours of the day. Customer's benefit will be categorized in two parts; premium payment and strike payment. The former is paid even if there is no call, however the later will be only paid if there is call and participating consumer reduces its demand as mentioned by the contract. The electric demand of appliances (such as conveyers, chillers, operating robots) is taken into account and DR program is optimized constrained by avoiding customer's inconvenience. Authors in [20] modeled participation of residential consumers in DR plans. The objective is to understand how much the distribution company's load profile can be flattened under different customer *convenience levels*. The novelty of this work is to make a connection between appliance-level flexibility concept and its impact on higher-levels of power system. Demand participation in primary, secondary, and tertiary reserve markets is investigated in [21]-[22]. The value of flexible loads is elaborated. It is shown that it makes more scenes both economically and technically that DRA provides primary reserve than secondary and tertiary reserves. The reason is that first, the needed volume of primary reserve is comparatively low which is suitable for relatively small size of DRAs. Second, it is usually easy for consumers to cut off a part of their load if sufficient financial incentives exist. In the next section the problem is defined in more detail. Then the methodology to address the problem is given and based on that the problem is formulated. Results illustrate that the proposed methodology successfully shifts the peak load to off-peak

periods. Then the functionality of the proposed method is investigated on shifting the electric vehicle charging loads.

### **5.3 The role of demand response aggregator**

Aggregation is an action which reinforces small-scale residential, commercial, and industrial consumers or producers to form a large-scale group to actively participate in electricity market. From this point, an aggregator can be described as a constitutional organization which aggregates these small-scale groups to steer them into a centralized systematic business structure [23].

Demand Response (DR) and Demand Side Management (DSM) are useful tools to enhance power system flexibility. In [24], DSM is defined as a task for power companies/utilities with the objective to increase electricity usage efficiency through the implementation of policies and methods that control electricity demand. It can be characterized by a “top-down” approach from a macro level of power company/utility to the micro level of individual costumers or producers. On the other hand, DR shows a “bottom-up” characteristic in which customers actively change their consumption periods/quantity in response to the dynamic electricity market prices. Thus, customers benefit from incentive payments at peak demand periods by reducing or shifting their electricity consumption [25].

For an efficient DSM and DR operation, Distributed Generation (DG), flexible loads, and controllable electrical and thermal storage devices are required as flexible Distributed Energy Resources (DER). They should have two important characteristics for being flexible: controllability and adaptability. It means that they must be controlled remotely through a communication infrastructure and they should adapt to different operation conditions based on the incentives and price signals. In Fig 5.1, an aggregator business model is given and the interaction between aggregator and other main units is explained in a regulatory framework.

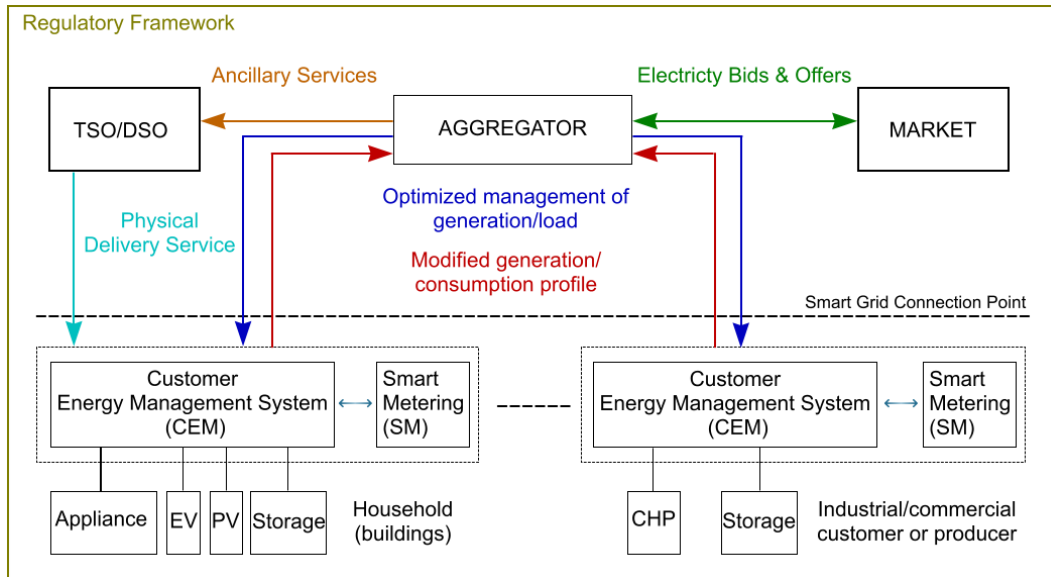

Fig 5.1 Demand response aggregator business model

Here regulatory framework is a background for the system that governs all units and defines the interaction between them in terms of services and also economic transactions. Flexible DER units, the electricity market, DSO/TSO and the aggregator can be thought as key players that interact with each other within this framework. Moreover, there should be a cost-efficient and secure communication infrastructure for a reliable exchange of services involved in aggregation. In Fig 5.1, it is seen a common smart grid connection point (SGCP) which connects customers to the network by means of a customer energy manager (CEM) and a smart metering device (SM). SM measures site-specific information and CEM optimizes energy consumption based on consumer's settings and contracts [26].

In this system, aggregator is responsible for summing up flexibilities from several CEMs and actively participates in markets. DER offers its generation and consumption flexibility to the aggregator who in return provides an economically optimized schedule of operation to the flexible units. They may have partial or full monitoring and remote control rights depending on their contracts with flexible DERs. Moreover, aggregator interacts with the electricity market by purchasing and selling electricity. It should be noted that aggregation business model could be implemented either by a new player or by an existing one, such as DSO. However, here aggregator will be considered as a different player to clearly distinguish the roles of different participants.

## 5.4 Formulation of price modification scheme

In this part of the chapter the problem formulation is presented, and then the simulation details and results are presented. As mentioned earlier the core idea here is to increase the price in peak hours and decrease it in off-peak hours so that there is a higher incentive for load shifting. The objective function is to increase the price difference between peak and off-peak hours. A larger price difference between the peak and off-peak price encourages load shifting<sup>11</sup>. Mathematical framework increases the peak price and decreases the off-peak price until a constraint is about to be violated. The constraints here are the following; first, the average of modified price set should remain the same as average of original price set. Second, the price modification should be limited to a pre-defined range, for instance only 20% higher or lower than the original price. The problem can be written as:

$$\max \sum_{i=i^{p,s}}^{i^{p,e}} q(i) - \sum_{i=i^{o,s}}^{i^{o,e}} q(i) \quad (5.1)$$

*Subject to:*

$$\text{for } i = i^{p,s}, \dots, i^{p,e} \quad q(i) \geq p(i) \quad (5.2)$$

$$\text{for } i = i^{o,s}, \dots, i^{o,e} \quad p(i) \geq q(i) \quad (5.3)$$

$$\text{for } i = 1, \dots, 24 \quad \alpha p(i) \leq q(i) \leq \beta p(i) \quad (5.4)$$

$$\text{for } i = 1, \dots, 24 \quad \text{ave}(p(i)) = \text{ave}(q(i)) \quad (5.5)$$

Where the variables and constants are introduced as follows:

$p$	original price set (known)	$i^{o,e}$	off-peak period ends
$q$	modified price set (variable)	$i^{p,e}$	peak period ends
$i^{p,s}$	peak period starts <sup>12</sup>	$i^{o,s}$	off-peak period starts

The first constraint assures that for peak period the modified prices are greater or equal than the original prices. Similarly the second constraint guarantees that for off-peak hours the original prices

<sup>11</sup> In a general categorization, demand response programs are direct load control and indirect load control (by means of price signals). The methodology proposed in this chapter falls in indirect demand control category.

<sup>12</sup> System operators know by experience when the peak periods are in different seasons. For instance in Denmark the peak in winter time is between 6 pm to 9 pm.



are less or equal than the original prices. The third constraint assures that the price modification should remain in the pre-defined range ( $\alpha$  and  $\beta$ ). For instance 10% price modification is allowed ( $\alpha = 0.9$  and  $\beta = 1.1$ ). The fourth constraint maintains the average price the same before and after price modification. The mentioned problem formulation decreases the peak load by modifying the prices in 24 hours of a day.

### 5.5 Simulation results for price modification scheme

Fig.5.2 and Fig.5.3 shows the modified price for different allowed price modification percentages in January and July 2014. The peak price in January is between 6-9 pm and in July it is between 8-11 pm. It can be seen that the price increases in the peak hours and decreases in the off-peak hours. Also as price modification percentage increases, the price is further increased in the peak hours and further decreased in the off-peak hours.

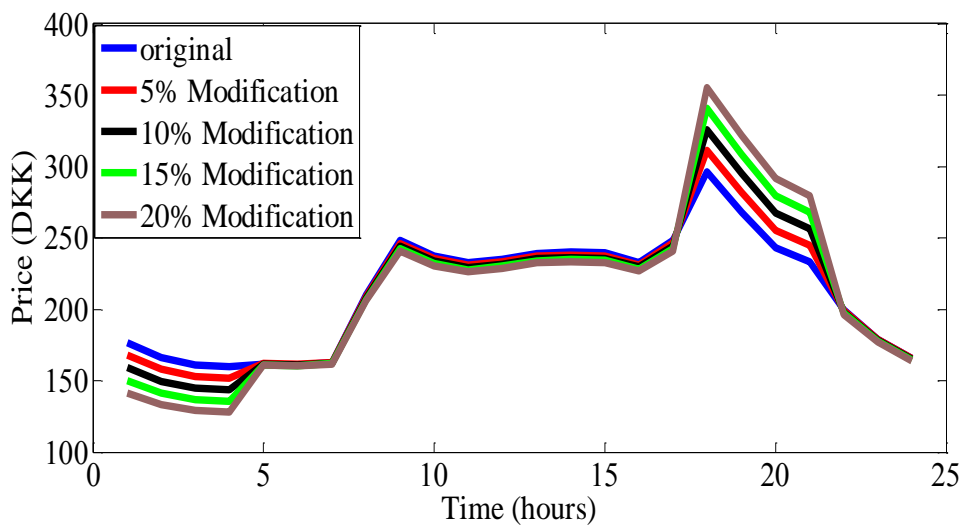

Fig. 5.2 Original and modified day-ahead market price- January 2014

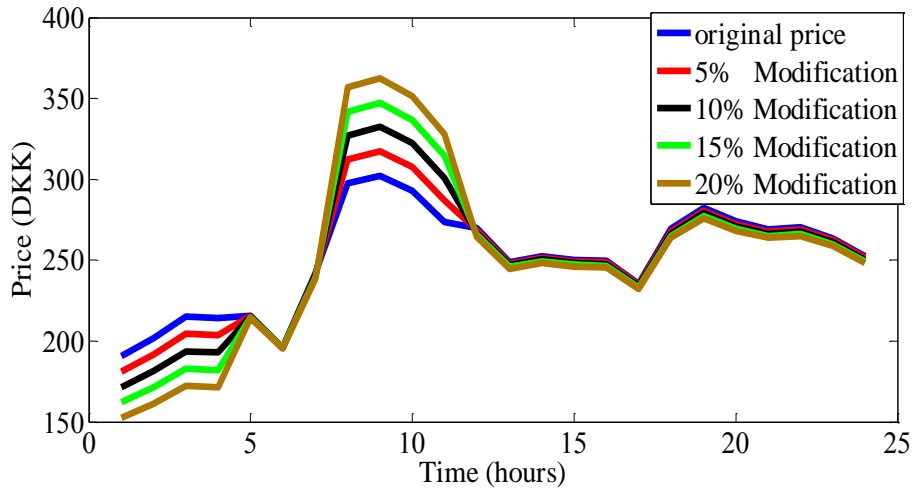

Fig. 5. 3 Original and modified day-ahead market price- July 2014

It is assumed that Demand Response Aggregator (DRA) has three types of load under its control. These loads have different price responsiveness levels (different elasticity). Type 1 has 5% price responsiveness which means that if price grows 100%, demand will be reduced 5%. The load responsiveness of type 2 is 10% which means if price grows 100%, demand will be reduced by 10%. Type 3 has step-wise load elasticity in which demand shows discontinues behavior versus price growth. Fig.5.4 shows price-demand curves for the mentioned load groups.

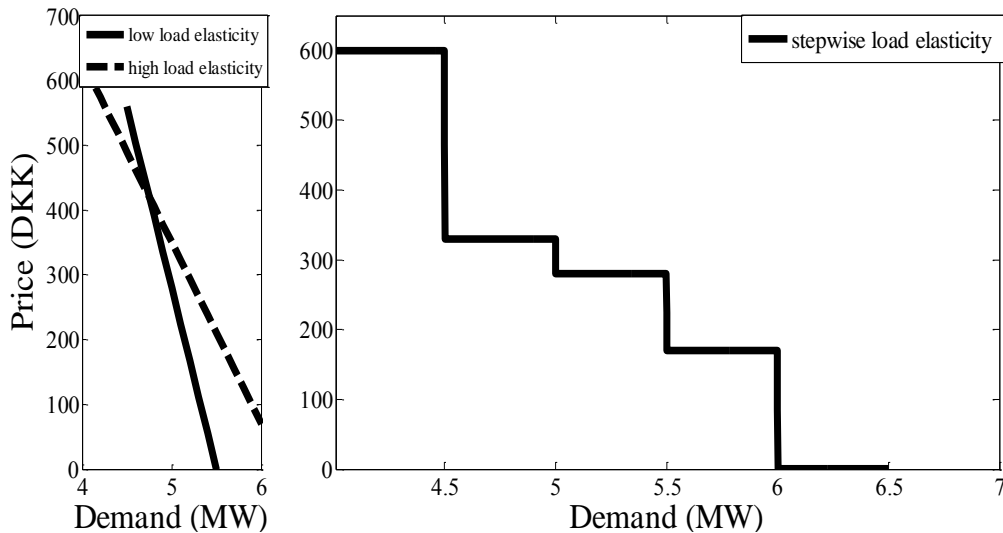

Fig. 5.4 Price responsiveness of load

Considering price responsiveness of three load groups, demand versus price functions are derived as shown in Table I.

TABLE I. DEMAND VERSUS PRICE FUNCTIONS

Type 1	$Demand(i) = -0.00178 * price(i) + 5.5$
Type 2	$Demand(i) = -0.00446 * price(i) + 6.25$
Type 3	$Demand(i) = 6 * (u^{13}(price(i)) - u(price(i) - 170))$ $+ 5.5 * (u(price(i) - 170) - u(price(i) - 280))$ $+ 5 * (u(price(i) - 280) - u(price(i) - 330))$ $+ 4.5 * (u(price(i) - 330) - u(price(i) - 600))$

Having the new price set, the corresponding demand can be calculated using the introduced functions. Fig. 5.5 compares two cases; demand applying original price with demand applying modified price. It is observed that peak demand is reduced when the modified price set is applied. On the contrary the off-peak demand will be increased which shows a successful load shifting from peak to off-peak hours<sup>14</sup>.

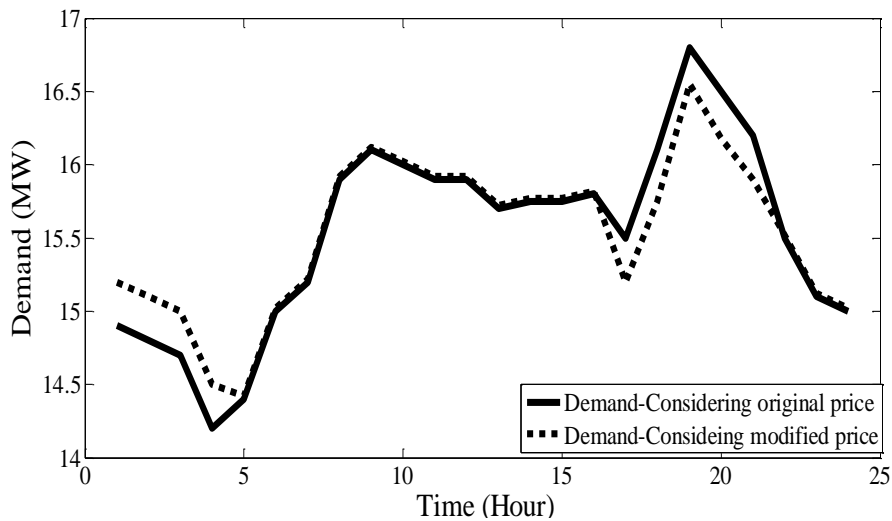

Fig. 5.5 Demand considering original and modified prices-January 2014

<sup>13</sup>  $u(\cdot)$  is the step function.

<sup>14</sup> Same figure can be plotted considering price and demand for July 2014. Similarly the load is shifted. The only difference with Fig. 5.5 is that the peak load in July happens in the morning time (8 am-11 am).

It should be noted that the proposed price modification is intended to reduce power system stress conditions (by reducing peak power) and the price change is not intended to increase the revenue for demand response aggregator. Fig.5.6 and Fig.5.7 show the revenue difference under two price sets in January and July 2014 (hourly average over one month).The revenue difference is calculated using the following equation ( $D(q(i))$  is demand when price is  $q(i)$ ):

$$\text{revenue difference } (i) = D(q(i)) * D(q(i)) - D(p(i)) * p(i) \quad (5.6)$$

Based on (5.6) the sum of revenue difference is calculated. The calculation shows that the revenue is decreased 782 DKK and 466 DKK in an average day in January and July (around 1% of total daily revenue). One may ask why DRA may want to decrease its revenue by implementing the proposed program. It should be mentioned that reduced peak hour increases the reliability of the power system by reducing power system peak load. The enhanced system reliability can be investigated by reliability indices such as LOLP (Loss of Load Probability) or EENS (Expected Energy Not Supplied). The contribution of each DRA for improving these indices can be rewarded by the system operator. This will be an incentive for aggregators to implement the proposed idea.

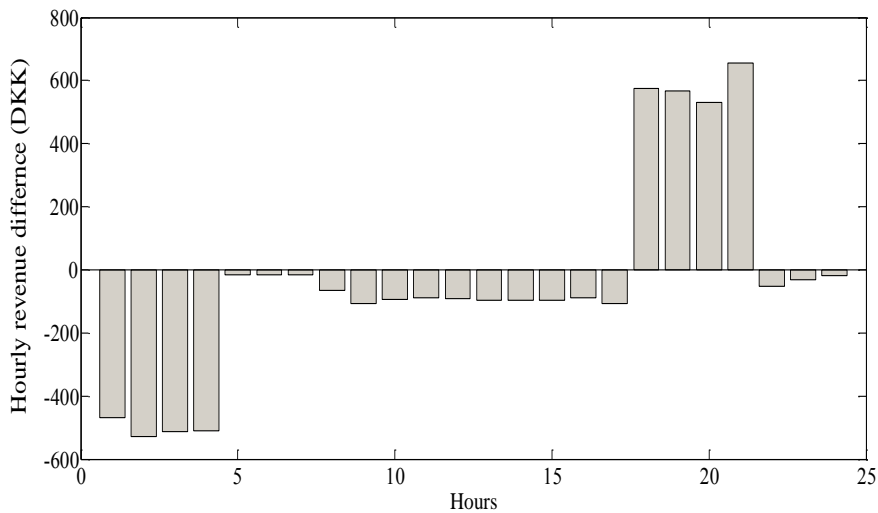

Fig.5.6 DRA revenue difference- January 2014

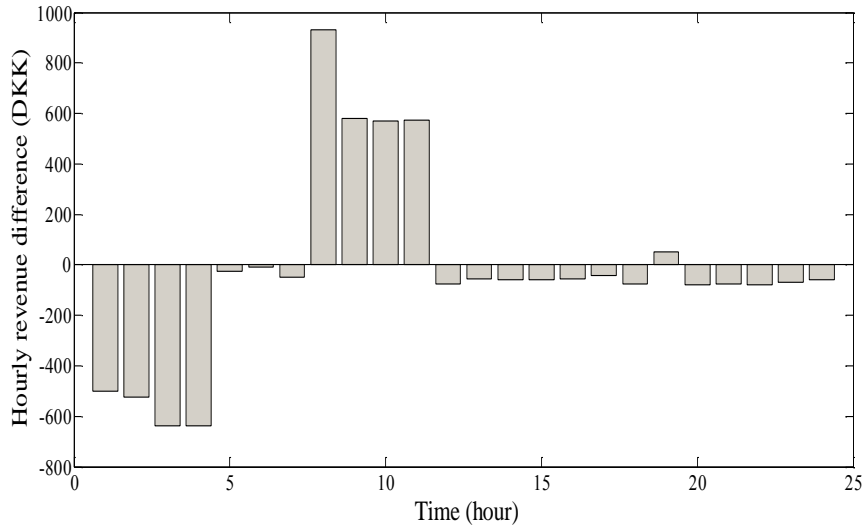

Fig. 5.7 DRA revenue difference- July 2014

### 5.6 The impact of new pricing scheme on EV charging

The functionality of the proposed method is investigated on shifting the electric vehicle loads. A distribution feeder in Denmark is chosen as the test grid (Børup distribution feeder). The maximum and minimum feeder’s load in 8760 hours in 2013 is shown in table II.

TABLE II. LOADING IN THE TEST GRID

	<b>1</b>	<b>2</b>	<b>3</b>	<b>4</b>	<b>5</b>	<b>6</b>	<b>7</b>	<b>8</b>	<b>9</b>	<b>10</b>	<b>11</b>	<b>12</b>	<b>13</b>	<b>14</b>	<b>15</b>	<b>16</b>	<b>17</b>	<b>18</b>	<b>19</b>	<b>20</b>	<b>21</b>	<b>22</b>	<b>23</b>	<b>24</b>
<b>Max</b>	76	80	82	91	81	91	101	107	108	101	97	89	77	73	84	108	127	133	129	114	91	76	72	73
<b>Min</b>	13	13	12	12	13	13	13	14	17	14	13	11	11	12	10	14	16	14	18	19	18	17	14	11

Fig.5.8 illustrates a single line diagram of the test feeder, which illustrates feeder topology including physical connections of 45 detached residential consumers. Approximately 60% of consumers have 3-6 kW rooftop grid-tied PVs, 35% consumers have heat pump (HPs), and 100% consumers have smart meters. In addition, some consumers already have EVs and many are expected to have EVs as a part of smart grid demonstration projects. Short line model is used for modeling feeder branches where every branch is modeled by series impedance. Consumer loads are modeled as three phase constant power load and the power factor is taken as 0.95 lagging.

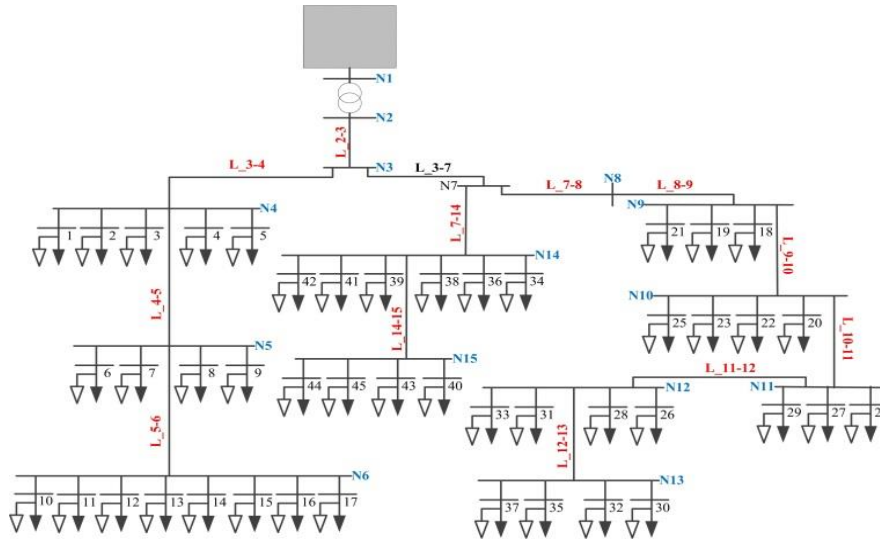

Fig. 5.8 Single Line diagram of test case network

From power system perspective, electric vehicles (EVs) are seen as a battery load. Therefore, they can be electrically modeled on the basis of charger rating ( $P_{chg}$ ) and battery capacity ( $B_{cap}$ ). For the present work, the  $P_{chg}$  and the  $B_{cap}$  are taken as 11 kW and 25 kWh respectively. The charger rating of 11 kW is selected to suit existing power supply (3 Ph., 16 amp.) in Denmark whereas the battery capacity of 25 kWh is chosen such that the EV can drive 100 km without the need of intermediate charging. Note that driving efficiency of 150 W/km and battery efficiency of 90% are considered in this study.

As such, the EV is modeled as constant power load with unity power factor, whereby the charging power ( $P_{chg}$ ) is continuous control variable from zero to 11 kW. The EVs have significant rating compared to the normal residential loads. As such, their higher penetration in the existing networks poses various problems. However, being the sizable loads with power storage facility, the EVs can support the network in various ways such as for valley filling, congestion management, load shifting, and so forth. EV driving patterns including EV availability, arrival/departure time, travelling distances, plays a key step in quantifying impacts of EVs on the distribution network and in extracting their potential for supporting the network. The daily driving distance, driving periods, and availability of EV are configured according to the statistical analysis of light cars in Denmark [20]. Note that those data plays a great role to determine driving requirement and to develop proper EV charging strategies. Fig. 5.9 illustrates the availability of EVs and arrival and departure of EVs over a day extracted from [20].

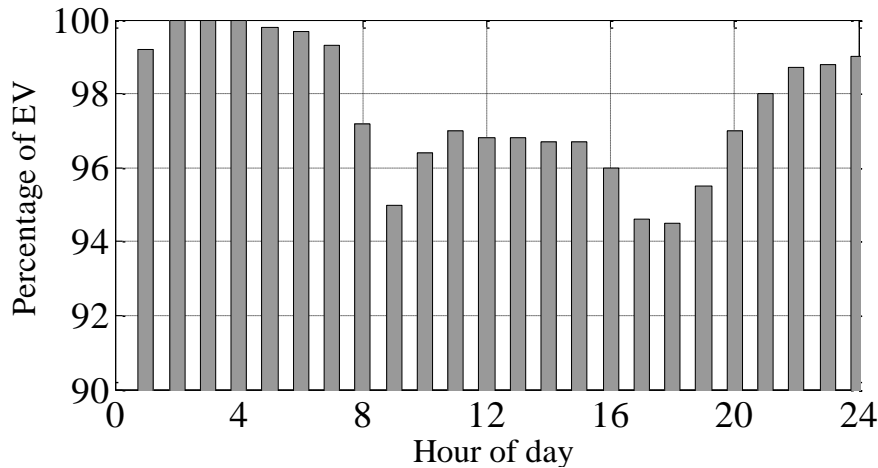

Fig. 5.9 Availability of EVs over 24 hours in Denmark

The primary message from this figure is that most of the EVs are available for charging throughout a day as it can be observed that more than 90% of the EVs are available for charging throughout the days whereas almost 100% of the EVs are available for charging at midnight. Therefore, the EVs, in this study, are used as potential demand response resources which are sensitive to the electricity price and modify their charging taking into account system balancing needs.

### 5.6.1 Optimal EV scheduling

In order to find a deep insight into the functionality of the proposed methodology, we integrated optimal EV scheduling together with the optimal electricity pricing. Note that the EV charging problem in this study is seen from the prospective of an aggregator or an entity which is responsible for demand side management programs. Normally EV owners do not care about network issues; they rather want to have minimum electricity bills. As such, the proposed optimum EV scheduling is modeled such that total charging cost of the EVs is minimized. Even though the presented study is seen from an aggregator perspective where the total charging cost of the entire EV charging is minimized, the charging cost of the individual EV owners also gets reduced. The decreased charging cost of the EV owners thus forms incentives for them to participate for supporting the network in various ways. The EV charging problem is formulated as a minimization problem where the objective is to minimize the EV charging cost.

$$\text{Minimize } \sum_{k=1}^K \sum_{i=1}^N P_{i,k} \delta C_k \quad (5.7)$$

*Subjected to:*

$$P_{min,i} < P_{i,k} < P_{max,i} \quad (5.8)$$

$$SOC_{i+1} = SOC_i + P_i \quad (5.9)$$

$$SOC_{T_{out},i} = SOC_{max} \quad (5.10)$$

$$SOC_{min} \leq SOC_i \leq SOC_{max} \quad (5.11)$$

$$\sum_{i=1}^N P_{i,k} \leq AC_{EV,k} \quad (5.12)$$

Where  $P_{i,k}$ ,  $\delta$ , and  $C_k$  are charging rate of  $i^{th}$  EV, slot duration (15 minutes in this study), and electricity price for the  $k^{th}$  slot, respectively.  $P_{min,i}$  and  $P_{max,i}$  are limiting values of EV charging rates for the  $i^{th}$  EV, and  $SOC_{min}$  and  $SOC_{max}$  are the minimum and maximum allowable state of charge (SOC).  $N$  is total number of EVs and the  $K$  is total number of time slots considered for the EV charging. The objective function is formulated such that the total EV charging cost subject to network thermal constraints is minimized.

The 1<sup>st</sup> constraint is used to ensures that the charging rate of every EVs stays within the charger capacity limits, the second constraint makes the relationship between state of the charge of the battery and the received energy whereas the 3<sup>rd</sup> and 4<sup>th</sup> constraints are used to ensure the consumer travel requirements. Similarly, the 5<sup>th</sup> constraint ensures that feeder load is within the maximum feeder capacity.

A linear optimization solver available in optimization tool-box of MATLAB is used to optimize the EV charging profiles. Note that the computed optimum schedules are made from aggregator or fleet operator perspectives. If the optimized EV charging schedules bring voltage violations, the EVs are rescheduled based on their SOC for contributing voltage support. In fact, all EVs are prioritized in descending order of their SOC. Whenever, the optimized EV charging results in voltage violations, the charging power of the EVs having higher SOC is decreased to zero and the process continue until network voltage returns back to the limit.



### 5.6.2 Integration of the optimal pricing and optimal EV charging

As discussed before, the optimal pricing is targeted for shifting the loads from high peak periods to the off peak periods. Being sizable electrical loads, the integration of optimal EV charging provides increased load shifting potential. Therefore, such studies are crucial to see the potential of the optimal pricing approach to shift the demand under high penetration of flexible loads. A summarized form of the integration of the optimal pricing and the optimal EV charging approach is illustrated in Fig.5.10, which is detailed as follows:

Firstly, day-ahead electricity prices are optimally adjusted using the procedure presented in Section II. The new price sets are dispatched to every consumer assuming that the consumers shift their loads as expected in response to the price changes. However, the price-based control normally incurs high uncertainties in consumer responsiveness as it depends highly on consumer's sensitiveness to the electricity price. For this reason, the expected demand shifting might not be achieved using the price changes. In this scenario, smart control of flexible loads could be a desirable option. Therefore, optimum EV scheduling is proposed to facilitate consumer responsiveness to the price changes since the EVs are fully flexible loads. In addition, as discussed in the preceding section, any violation in the network voltage trigger EV rescheduling such that the EV charging power is decreased in descending order of the SOC as illustrated in Fig. 5.10.

### 5.6.3 Simulation configuration

The performance of the proposed method is demonstrated through 24 hours. The 24-hours timeframe is discretized into 96 time intervals each for 15 minutes. To analyze the worst case scenario, maximum demand day in 2013 is taken for the analysis. EV penetration in the studied distribution feeder is considered to be 60% meaning that 60% of the consumer have EVs. Each EV are having 11 kW (3 phases, 16 A) charger capacity and 25 kWh battery capacity<sup>15</sup>. Further, the plug-in and plug-out of the EVs are configured based on the EV availability data illustrated in Fig. 5.11. The performance of the proposed approach is demonstrated by technical and economical perspective for EV charging. To illustrate significance of the proposed method, the impact of high EV penetration in the network is first examined. Thereafter, the effectiveness of the proposed

---

<sup>15</sup> It takes around two hours for a discharged EV to be fully charged. (the size of the battery is 25 KWh and the charging rate is 11 KWh)

method is quantified with respect to the following three cases: a) base case where the electricity price is same as the day ahead price. b) case where 5% change in the day ahead electricity price is allowed. c) case where 20% change in the day ahead electricity price is allowed.

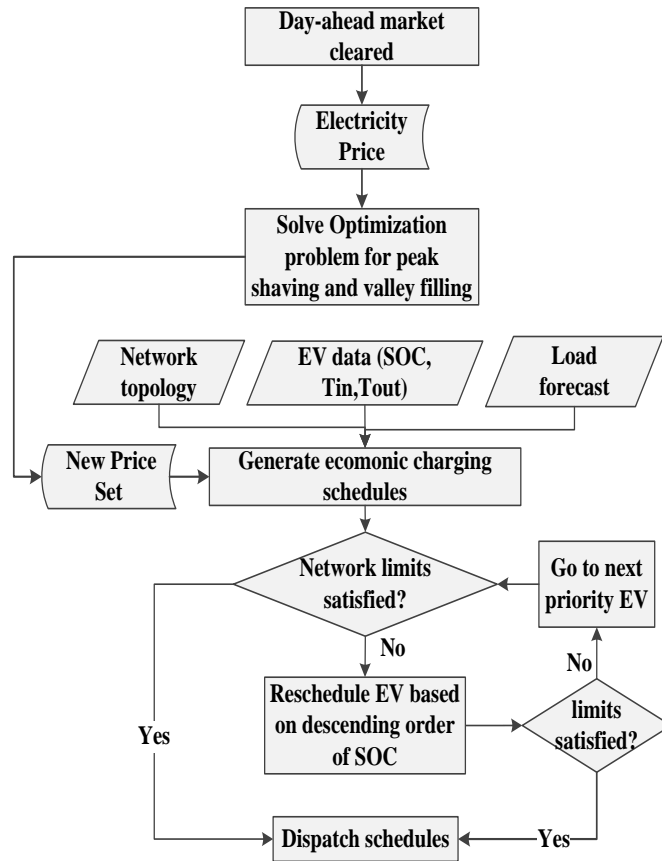

Fig. 5.10 Single line diagram of test case network

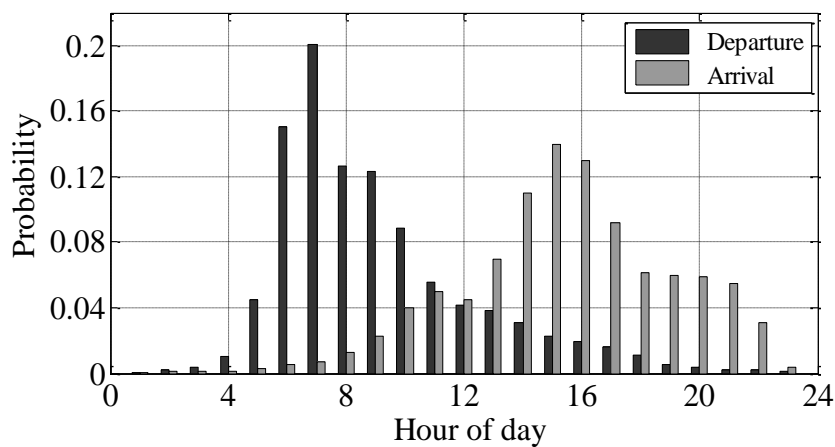

Fig. 5.11 Plug-in and plug-out time of EVs over 24 hours

### 5.6.4 Simulation for optimal EV scheduling

To illustrate the impact of high EV penetration on the LV distribution network, an uncontrolled EV charging approach is implemented, where the EV start charging once they arrive home and continue until fully charged. As shown in Fig. 5.12 most of the EVs charge between 15:00 to 24:00. As such, the EV charging demand coincides with the feeder peak periods which lead to poor voltage profile. It can be observed from Fig.5.13 that the voltage profile of far end terminal (Node 13 as shown in Fig. 5.8) drops below 0.94 p.u. during the peak periods from 18:00 to 21:00.

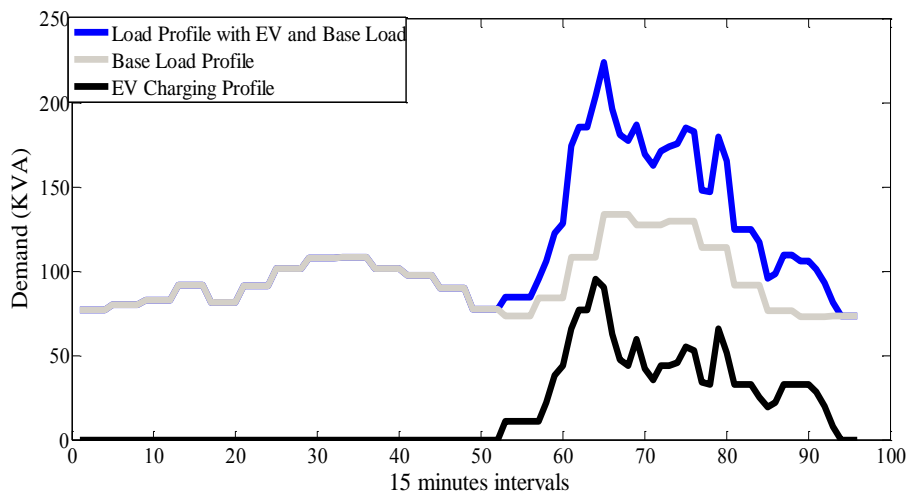

Fig. 5. 12 EV charging profile during uncontrolled charging

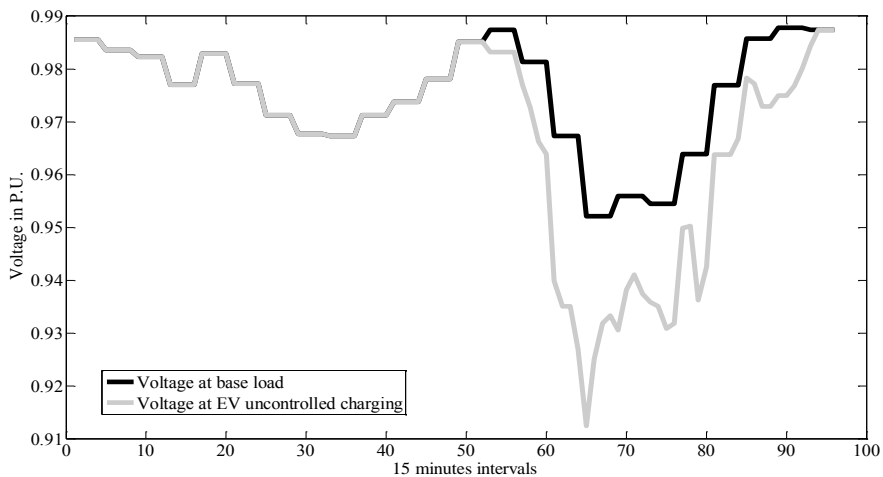

Fig. 5.13 Voltage profile at node 13 during uncontrolled charging

Using the algorithm introduced in Fig. 5. 10, the effectiveness of the change in electricity price on the optimal charging of EVs is given in this section. The new set of prices are calculated and shown in Fig. 5. 14.

The EV charging profile on three different cases is illustrated in Fig. 5.15. Furthermore, the Fig. 5.16 illustrates total feeder load profile i.e. the sum of EV charging load and base load. It can be observed from these figures that the EV charging profile is more distributed when 20% price change is allowed. Compared to the base case, the EV charging profile is shifted more evenly during the case when the price change is allowed.

It can be observed that higher the change in price is allowed, higher the shifting of the EV charging loads can be achieved. Larger difference between peak and off-peak price enhances load shifting. Note that the EVs are considered as fully flexible loads such that the EV charging can be shifted to any periods, provided the EV should be fully charged on time as specified by the EV owner. Total charging costs under different scenarios are compared in Fig. 5.17 where it is shown that implementing the proposed methodology decreases the charging cost.

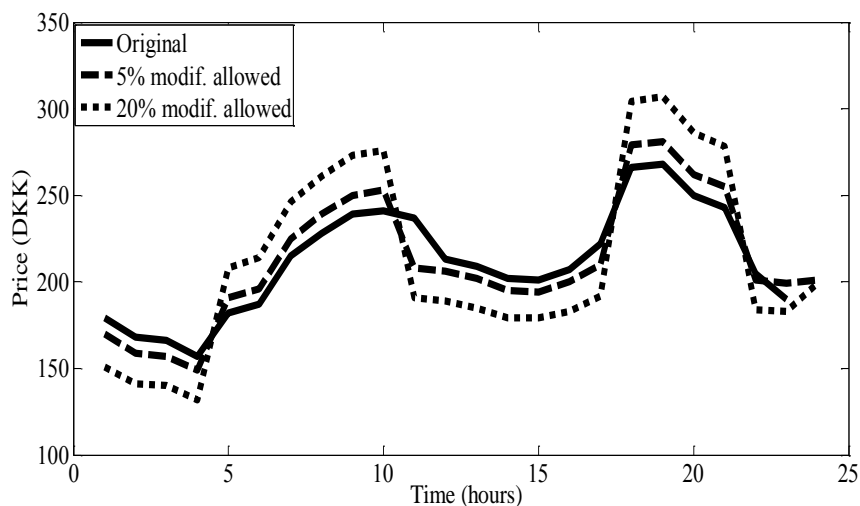

Fig. 5.14 Original and modified price sets in distribution feeder

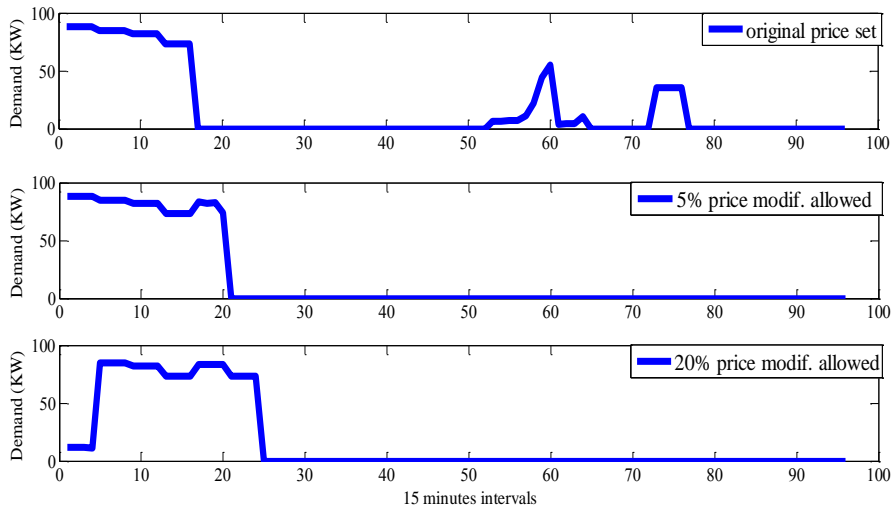

Fig. 5.15 EV charging profile during various cases

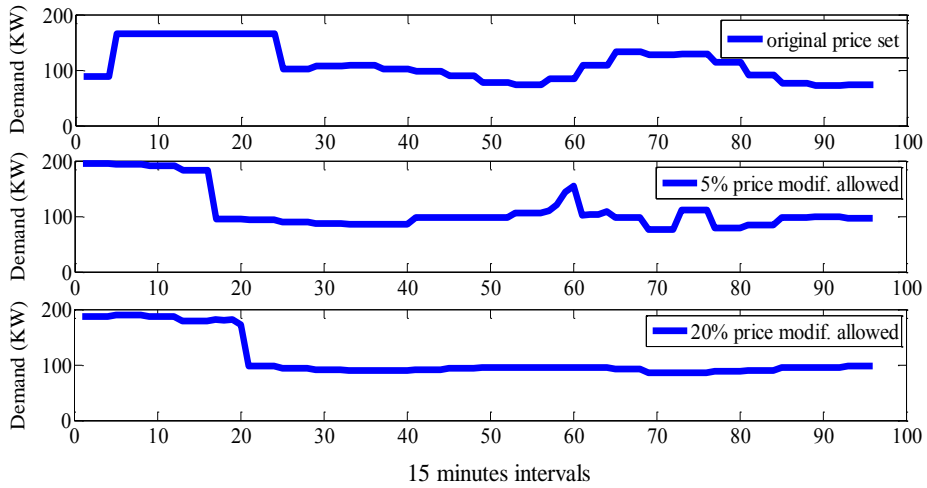

Fig.5.16 Feeder load profile (EV load + base load) during various cases

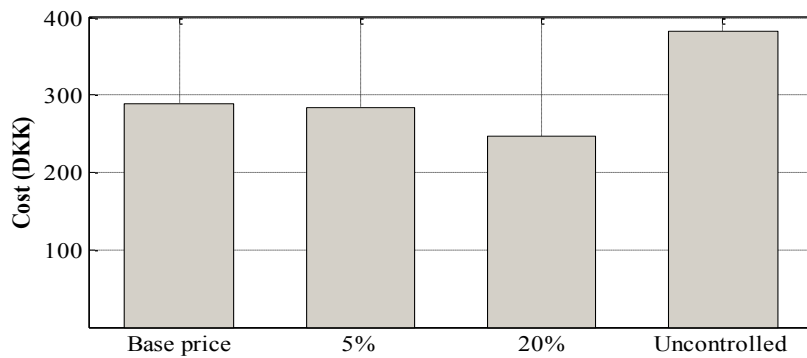

Fig. 5.17 Total EV charging cost during various cases

From the aforementioned analysis, it can be inferred that the proposed integrated EV charging optimization and electricity pricing approach is well suited to address the impact of future electrical loads in the network by properly shifting their demand to the off-peak periods. In addition, the optimal pricing mechanism can be implemented for supporting the network in various ways such as for load shifting, peak shaving, valley filling etc. More importantly, the optimal pricing has the capability to shift the loads significantly in the future as large penetrations of flexible loads are expected. This study also shows that high penetration of EV in a given distribution feeder can cause a load peak in so called off-peak hours (from midnight to 4-5 a.m.). It should be noted that EV penetration is assumed to be 60% in this study. This is fine from transmission point of view because power system is lightly loaded in these hours. However from a distribution point of view the voltage problems may be just shifted from evening to midnight which can be equally undesired.

## **5.7 Summary**

This chapter proposes an optimization framework to increase demand responsiveness. It is argued that the price difference between peak and off-peak hours is not incentivizing enough to encourage consumers to shift their loads from peak to off-peak periods. The optimization framework magnifies the price difference between peak and off-peak hours. The result is a new set of prices under which the peak demand is reduced (and thus power system security is enhanced). To consider social fairness, the price modification is systematically controlled. First, the framework implies that the price modification is limited by a pre-decided factor in all peak, mid-peak and off-peak hours. Second, the daily average price of modified price should remain the same with that of original price set. Then the impact of proposed idea is investigated for reducing the load in a distribution feeder which has high EV penetration.

## References

- [1] Lund, H., Mathiesen, B. V, "Energy system analysis of 100% renewable energy systems-The case of Denmark in years 2030 and 2050", *Energy* 2009, *34*, 524–531.
- [2] Kim, J. H, Shcherbakova, A, "Common failures of demand response", *Energy* 2011, *36*, 873–880.
- [3] International Energy Agency *The Power to Choose, Demand Response in Liberalized Electricity Markets*; 2003; Vol. 11, p. 156.
- [4] De Jonghe, C., Hobbs, B. F., Belmans, "Optimal generation mix with short-term demand response and wind penetration," *IEEE Trans. Power Syst.* 2012, *27*, 830–839.
- [5] Nguyen, D. T., Negnevitsky, M., De Groot, M. "Pool-based demand response exchange-concept and modeling, " *IEEE Trans. Power Syst.* 2011, *26*, 1677–1685.
- [6] Wijaya, T. K. Vasirani, M. Aberer, K. "When bias matters: An economic assessment of demand response baselines for residential customers", *IEEE Trans. Smart Grid* 2014, *5*, 1755–1763.
- [7] Wang, Y. Pordanjani, I. R. Xu, W "An event-driven demand response scheme for power system security enhancement", *IEEE Trans. Smart Grid* 2011, *2*, 11–17.
- [8] Sahin, C. Shahidehpour, M. Erkmén , "Allocation of hourly reserve versus demand response for security-constrained scheduling of stochastic wind energy", *IEEE Trans. Sustain. Energy* 2013, *4*, 219–228.
- [9] Goel, L, Wu, Q. W. Q., Wang, "Reliability enhancement of a deregulated power system considering demand response" *2006 IEEE Power Eng. Soc. Gen. Meet.* 2006.
- [10] Parvania, M. Fotuhi-Firuzabad, M. Shahidehpour, M. "Optimal demand response aggregation in wholesale electricity markets," *IEEE Trans. Smart Grid* 2013, *4*, 1957–1965.
- [11] Koliou, E., Eid, C., Chaves-Ávila, J. P., "Hakvoort, R. A. Demand response in liberalized electricity markets: Analysis of aggregated load participation in the German balancing mechanism, " *Energy* 2014, *71*, 245–254.
- [12] Mahmoudi, N., Eghbal, M., Saha, T. K. "Employing demand response in energy procurement plans of electricity retailers" *Int. J. Electr. Power Energy Syst.* 2014, *63*, 455–460.
- [13] Mahmoudi, N., Saha, T. K., Eghbal, M. "Modelling demand response aggregator behavior in wind power offering strategies, " *Appl. Energy* 2014, *133*, 347–355.
- [14] Filippini, M., Pachauri, S., "Elasticities of electricity demand in urban Indian households, " *Energy Policy* 2004, *32*, 429–436.

- [15] He, Y. X.; Yang, L. F.; He, H. Y.; Luo, T.; Wang, Y. J. Electricity demand price elasticity in China based on computable general equilibrium model analysis. *Energy* 2011, 36, 1115–1123.
- [16] Zarnikau, J., Landreth, G., Hallett, I., Kumbhakar, S. C. "Industrial customer response to wholesale prices in the restructured Texas electricity market, " *Energy* 2007, 32, 1715–1723.
- [17] Filippini, M, "Short- and long-run time-of-use price elasticities in Swiss residential electricity demand, " *Energy Policy* 2011, 39, 5811–5817.
- [18] Faruqui, A.; Hajos, A.; Hledik, R. M.; Newell, S. A "Fostering economic demand response in the Midwest ISO, " *Energy* 2010, 35, 1544–1552.
- [19] Oh, S. C., Hildreth, A. J. "Decisions on energy demand response option contracts in smart grids based on activity-based costing and stochastic programming, " *Energies* 2013, 6, 425–443.
- [20] Hassan, N., Pasha, M., Yuen, C., Huang, S., Wang, X, "Impact of Scheduling Flexibility on Demand Profile Flatness and User Inconvenience in Residential Smart Grid System, " *Energies* 2013, 6, 6608–6635.
- [21] Biegel, B., Westenholz, M., Hansen, L. H., Stoustrup, J., Andersen, P., Harbo, S. Integration of flexible consumers in the ancillary service markets, " *Energy* 2014, 67, 479–489.
- [22] Biegel, B., Hansen, L. H., Stoustrup, J., Andersen, P., Harbo, S. "Value of flexible consumption in the electricity markets, " *Energy* 2014, 66, 354–362.
- [23] The Main players of the DER aggregation field. Available online: <http://www.eudeep.com/index.php?id=653#5> (accessed on 04 December 2014)
- [24] Jin, Z., Chongqing, K., Kai, L. "Demand side management in China" In *IEEE PES General Meeting*; 2010; pp. 1–4.
- [25] Albadi, M. H., El-Saadany, E. F. "Demand response in electricity markets: An overview, " In *2007 IEEE Power Engineering Society General Meeting, PES*; 2007.
- [26] CEN-CENELEC-ETSI Smart Grid Coordination Group – Sustainable Processes. Available online:[http://ec.europa.eu/energy/gas\\_electricity/smartgrids/doc/xpert\\_group1\\_sustainable\\_processess.pdf](http://ec.europa.eu/energy/gas_electricity/smartgrids/doc/xpert_group1_sustainable_processess.pdf) (accessed on 04 December 2014)



## Chapter 6

### Reserve scheduling considering cross-border interconnections

This chapter addresses optimal reserve scheduling considering cross-border interconnections. A Danish case study will be presented to this end. Denmark avails the highest penetration of wind power in the world. Danish power system is subdivided into two asynchronous parts; western and eastern Danish power systems. With more than 35% wind penetration, western Danish power system has the merits to be considered as the pilot grid for many regions that plan for high penetration of intermittent renewables. Extreme intermittency in the nature of wind power imposes elevated risk levels to power system operation. This every day challenge of wind dominant power systems necessitate the crucial role of operating reserves. In this chapter, an optimization framework is proposed to minimize the cost of reserve procurement. The framework decouples the share of upward and downward primary, secondary, and tertiary reserve services within DK1 (western Danish power system) and neighboring cross border resources (Norway and Germany). Results indicate the economic benefit of reserve provision provided by cross border interconnections. The focus here will be on reserve services from abundant hydro power resource in Norway, taking advantage of fast VSC-based HVDC interconnection that is expected to be commissioned in immediate coming years.

#### 6.1 Introduction to existing literature and Danish power system

As the integration of intermittent sources of energy grows, more attention is paid to research activities in the scope of reserve services. This supports secure and optimal operation of power system in the presence of renewables. In [1] a simultaneous reserve and energy dispatching method is introduced. The methodology is decentralized and incorporates wind and equipment uncertainties in a multi-area system. The proposed approach reaches near optimum solution in an iterative manner. This methodology is functional for interconnected European electricity market. In [2] a scenario based two-stage stochastic programming framework for determining reserve requirement with high penetration of wind power is introduced. A dual composition algorithm for solving the problem is used. In a similar study in [3] a methodology is proposed to determine the required reserve (both spinning and non-spinning) in power systems with significant wind penetration. The

proposed simulation takes into account load curtailment and wind spillage. It is concluded that reserve cost and wind uncertainty are highly correlated. In [4] a framework is provided to carry out a multi-area power flow. Authors in [5] blame determining primary, secondary, and tertiary reserves by exogenous rules due to sub-optimality issues and encouraging simultaneous scheduling of energy and reserve. Here the salient feature is that, unlike current practices in many electricity markets around the world, under proposed approach the price for all reserve services are identical and definitely marginal. A cross-border transmission expansion assessment is presented in [6]. The assessment criteria are system security, competitiveness, and sustainability (CO<sub>2</sub> emission). In [7] and [8] probabilistic approach for determining spinning reserve requirement is introduced. The impact of wind penetration on reserve requirement is formulated in detail. In [9] an integer modeling approach is employed for reserve requirement determination in short term scheduling of hydro systems.

Danish power system is unique due to its important geographical location and leading role in large scale wind integration. Danish grid is comprised of two asynchronous systems, western and eastern grids which are interconnected through Great Belt HVDC link. Western Danish power system also known as DK1 is synchronized to continental Europe while as Eastern Danish power system also known as DK2 is synchronized with Nordic grid. The geographical map of Danish power system is shown in Fig. 6.1. Danish grid is strongly interconnected to neighboring countries through various HVAC and HVDC tie lines. On north side, DK1 is connected to Norway through three classical HVDC lines and one to be soon commissioned VSC-HVDC link and to Sweden through two 250 KV HVDC lines. On southern side DK1 is connected to Germany through four HVAC lines. DK2 is connected to Sweden, Germany, and DK1 through HVAC and HVDC lines respectively.

Denmark is one of the leading countries in wind energy integration which is currently harnessing more than 30% of electricity from wind. Denmark is having ambitious goal to achieve 100% fossil fuel free country by 2050 with 50% share of electricity from wind by 2020 [10]. Owing to large scale wind energy penetration and need for carbon emission reduction, most of central power plants are being planned to be scrapped out by 2025 [11]. It is also to be noted that most of the ancillary services are currently being provided by central power plants which has necessitated the operation of at least three and two central power plants respectively in DK1 and DK2 to maintain secure and stable operation of Danish power system [12]. Key figures of western and eastern Danish power system as of 2011 are given in Table I.

TABLE I. KEY FIGURES OF WESTERN DANISH POWER SYSTEM IN 2011

Description	ENDKW	ENDKE
Minimum Load(MW)	1400	900
Maximum Load(MW)	3700	2700
Primary Power Stations(MW)	3400	3800
Local CHP Plants(MW)	1643	640
Wind Turbines(MW)	2840	960

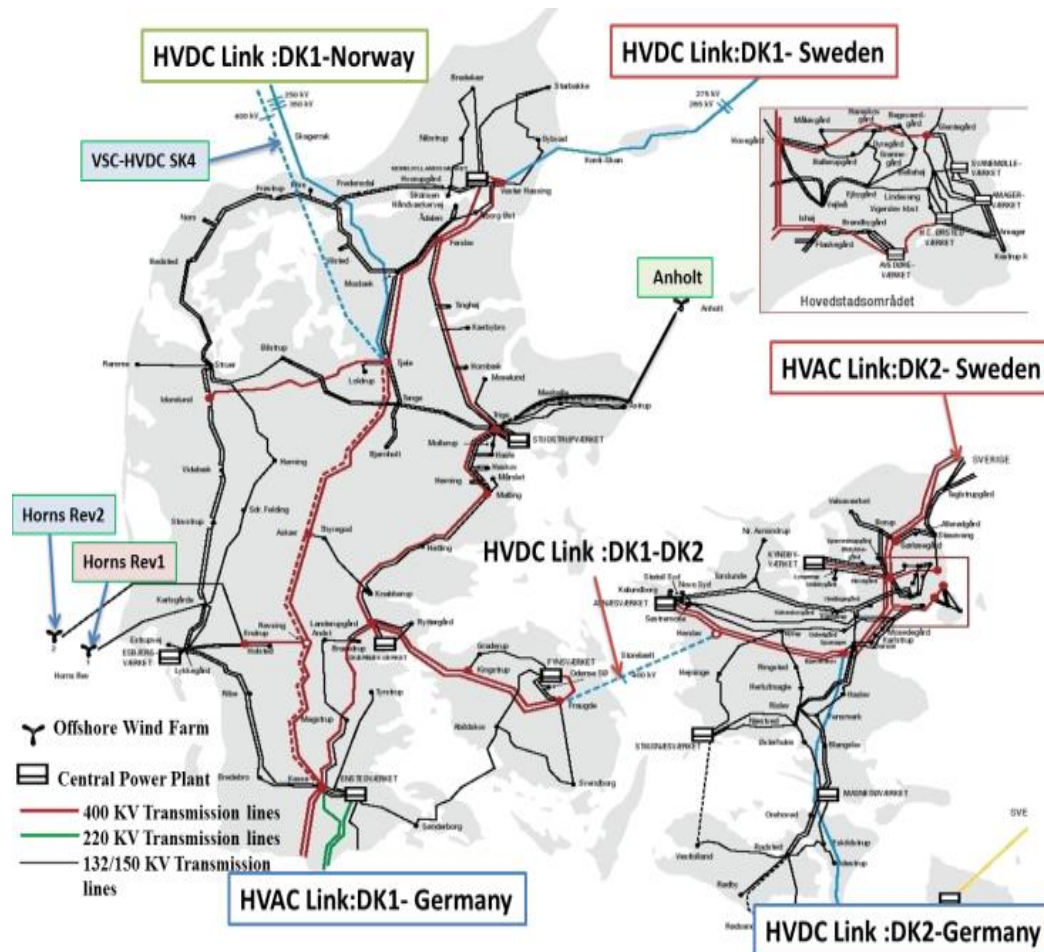

Fig.6.1. Geographical map of Danish power system with cross border connections

## 6.2 Reserve Market Services in Western Danish Power System

Due to large scale wind energy penetration and scrapping out central power plants, Danish power system need to identify other economic alternatives for ancillary services. The absence of central

power plants coupled with large scale wind energy integration poses a significant challenge of reserve requirement for Danish power system. On 20<sup>th</sup> January, 2005, around 02:33 hours, one of the first offshore wind farm in Denmark, *Horns Rev-1* witnessed reduction of production from its full load to zero in time span of just three minutes and this process was repeated quite a few times on the same night due to high wind speed [13]. Moreover offshore wind farms experience higher fluctuations in power production compared to onshore wind farms due to higher wind fluctuations especially during rainy season. Currently both Horns Rev-1 and Horns Rev-2 offshore wind farms are in operation and around 8 additional potential sites of 1600 MW capacity have been identified in the same belt. Therefore in future, assuming above mentioned incident as the worst possible case, deviation in power production just around the mentioned region can be as high as 1800 MW within time frame of 3 minutes.

Currently in Western Denmark, the primary and secondary reserve requirements are  $\pm 27$  MW and  $\pm 90$  MW respectively. Tertiary reserve has asymmetric values for upward and downward reserve, which are + 550 MW and -210 MW. Primary reserve can be supplied only by central power plants and settlement is done as defined by (6.1). The service is auctioned once per day.

$$\lambda_{pri} = \lambda_{avl} + \lambda_E \quad (6.1)$$

Where,  $\lambda_{pri}$  is the total price paid for primary reserve service to the participating unit,  $\lambda_{avl}$  is the availability price taken as highest accepted bidding price and  $\lambda_E$  is the price for energy volume supplied, paid at the rate of balancing market price.

Major portion of secondary reserve is also provided by central power plants even though other power plants can also participate through balance responsible party (BRP). Settlement of secondary reserves is done as defined in (6.2). Secondary reserve is auctioned on monthly basis.

$$\lambda_{sec} = \lambda_{sp} \pm 100 * P_{Es} \quad (6.2)$$

Where  $\lambda_{sec}$  is the total amount in DKK paid to the participating unit,  $\lambda_{sp}$  is the spot market price and  $P_{Es}$  is actual energy supplied in MWh, where positive and negative sign is for up and down regulation respectively.

Tertiary reserve required for DK1 is acquired in parts, 250 MW from DK1 and 300 MW from DK2. Danish TSO is having five year contract (kyndby agreement) with generation company, Dong Energy in Eastern grid, therefore 300 MW of tertiary reserve is acquired from DK2 and rest 250 MW is purchased through daily auctions from DK1.

In case of west bound flow on Great Belt HVDC link, additional reserve may also be acquired from DK1. The settlement of tertiary reserve bought in DK1 is done as defined in (6.3).

$$\lambda_{ter} = \lambda_{avlt} + \lambda_{Et} \quad (6.3)$$

Where,  $\lambda_{ter}$  is the total price paid for tertiary reserve service to the participating unit,  $\lambda_{avlt}$  is the availability price taken as highest accepted bidding price and  $\lambda_{Et}$  is the price for energy volume supplied, paid at the rate of balancing market price.

Currently HVDC tie lines with neighboring Nordic countries do not support fast change in power exchange due to market regulations. The market model adopted for LCC-HVDC tie line power exchange is shown in Fig. 6. 2, which does not allow fast changes in the amount of existing flow and the change in direction of flow is allowed hourly [14].

However a new 700 MW VSC-based HVDC link (SK4) between Norway and DK1 is recently commissioned which can be used to support reserve services in Denmark. Therefore, to take the advantage of mentioned VSC-HVDC link, this chapter evaluates the economic aspects of possible reserve provision by utilization of SK4 considering its fast dynamic response and more controllability.

It is also worth mentioning that the HVAC tie line of DK1 connecting with Germany has limitation on unscheduled interchange which should not exceed +/- 50MW, therefore in future where much stronger fluctuations in local generation are expected, alternatives to limit the unscheduled interchange within the acceptable ranges needs to be explored.

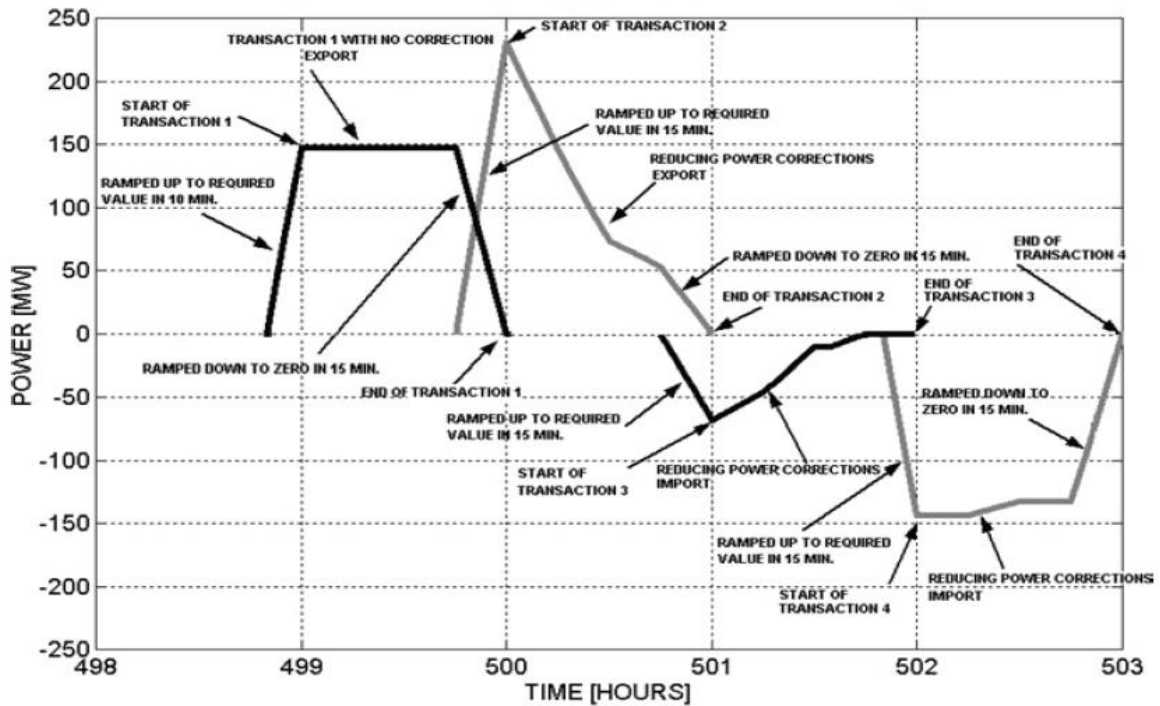

Fig. 6.2. Market settlement model for Power exchange with Nordic countries [14]

### 6.3 Formulation for decoupling different reserve services

Here a framework is proposed to minimize total cost of reserve for western Danish power system under different scenarios incorporating reserve expectation of interconnections (contract capacity for different reserve services) and the required reserve in DK1.

More specifically, we concentrate on investigating the economic benefit of increasing the contract capacity of Denmark-Norway HVDC interconnection for reserve purposes. According to our assumptions, thermal power plants and gas turbines within DK1 contribute to primary, secondary, and tertiary reserve provision.

Norway HVDC interconnection contributes to both primary and tertiary reserve services. Meanwhile the interconnection to Germany only contributes to secondary reserve needs in DK1. The objective function below to be minimized is Reserve Cost (RC). The nomenclature is follows:

#### A. Indices

- $i$  Indices of reserve providing units in DK1
- $j$  Indices of interconnections with Norway

$k$  Indices of interconnections with Germany

### B. Variables

$r_{DK,i}^{pu}$	Upward primary reserve of unit $i$ in DK1
$r_{DK,i}^{pd}$	Downward primary reserve of unit $i$ in DK1
$r_{NO,j}^{pu}$	Upward primary reserve provided by interconnection $j$ with Norway
$r_{NO,j}^{pd}$	Downward primary reserve provided by interconnection $j$ with Norway
$r_{DK,i}^{su}$	Upward secondary reserve of unit $i$ in DK1
$r_{DK,i}^{sd}$	Downward secondary reserve of unit $i$ in DK1
$r_{GR,k}^{su}$	Upward secondary reserve provided by interconnection $k$ with Germany
$r_{GR,k}^{sd}$	Downward secondary reserve provided by interconnection $k$ with Germany
$r_{DK,i}^{tu}$	Upward tertiary reserve of unit $i$ in DK1
$r_{DK,i}^{td}$	Downward tertiary reserve of unit $i$ in DK1
$r_{NO,j}^{tu}$	Upward tertiary reserve provided by interconnection $j$ with Norway
$r_{NO,j}^{td}$	Downward tertiary reserve provided by interconnection $j$ with Norway

### C. Constants

$R_{DK}^{pu-pd}$	Upward/downward primary reserve requirement in DK1
$R_{DK}^{su-sd}$	Upward/downward secondary reserve requirement in DK1
$R_{DK}^{tu-td}$	Upward/downward tertiary reserve requirement in DK1
$P_{max,i}$	Maximum capacity of unit $i$ in DK1
$P_{min,i}$	Minimum capacity of unit $i$ in DK1
$P_{g,i}$	Average generated power by unit $i$ in DK1
$Cap_{NO,j}^p$	Contract capacity of primary reserve for interconnection $j$ with Norway
$Cap_{NO,j}^t$	Contract capacity of tertiary reserve for interconnection $j$ with Norway
$Cap_{GR,k}^s$	Contract capacity of secondary reserve for interconnection $k$ with Germany
$b_i^{p,u/d}$	Binary Constant indicating whether unit $i$ in DK1 participates in upward/downward primary reserve markets
$b_i^{s,u/d}$	Binary Constant indicating whether unit $i$ in DK1 participates in upward/downward secondary reserve markets
$b_i^{t,u/d}$	Binary Constant indicating whether unit $i$ in DK1 participates in upward/downward tertiary reserve markets

$$\begin{aligned}
RC = & \sum_i C_{pu,DK}(r_{DK,i}^{pu}) + \sum_j C_{pu,NO}(r_{NO,j}^{pu}) + \sum_i C_{pd,DK}(r_{DK,i}^{pd}) \\
& + \sum_j C_{pd,NO}(r_{NO,j}^{pd}) + \sum_i C_{su,DK}(r_{DK,i}^{su}) + \sum_k C_{su,GR}(r_{GR,k}^{su}) \\
& + \sum_i C_{sd,DK}(r_{DK,i}^{sd}) + \sum_k C_{sd,GR}(r_{GR,k}^{sd}) + \sum_i C_{tu,DK}(r_{DK,i}^{tu}) \\
& + \sum_j C_{tu,NO}(r_{NO,j}^{tu}) + \sum_i C_{td,DK}(r_{DK,i}^{td}) + \sum_j C_{td,NO}(r_{NO,j}^{td})
\end{aligned} \tag{6.4}$$

*Subject to:*

$$\sum_i r_{DK,i}^{pu} + \sum_j r_{NO,j}^{pu} \geq R_{DK}^{pu} \tag{6.5}$$

$$-\sum_i r_{DK,i}^{pd} - \sum_j r_{NO,j}^{pd} \leq R_{DK}^{pd} \tag{6.6}$$

$$\sum_j r_{NO,j}^{pu} \leq \sum_j Cap_{NO,j}^p \tag{6.7}$$

$$\sum_j r_{NO,j}^{pd} \leq \sum_j Cap_{NO,j}^p \tag{6.8}$$

$$\sum_i r_{DK,i}^{su} + \sum_k r_{GR,k}^{su} \geq R_{DK}^{su} \tag{6.9}$$

$$-\sum_i r_{DK,i}^{sd} - \sum_k r_{GR,k}^{sd} \leq R_{DK}^{sd} \tag{6.10}$$

$$\sum_k r_{GR,k}^{su} \leq \sum_k Cap_{GR,k}^s \tag{6.11}$$

$$\sum_k r_{GR,k}^{sd} \leq \sum_k Cap_{GR,k}^s \tag{6.12}$$

$$\sum_i r_{DK,i}^{tu} + \sum_j r_{NO,j}^{tu} \geq R_{DK}^{tu} \tag{6.13}$$

$$-\sum_i r_{DK,i}^{td} - \sum_j r_{NO,j}^{td} \leq R_{DK}^{td} \tag{6.14}$$

$$P_{g,i} + b_i^{p,u} r_{DK,i}^{pu} + b_i^{s,u} r_{DK,i}^{su} + b_i^{t,u} r_{DK,i}^{tu} \leq P_{max,i} \tag{6.15}$$

$$P_{g,i} - b_i^{p,d} r_{DK,i}^{pd} - b_i^{s,d} r_{DK,i}^{sd} - b_i^{t,d} r_{DK,i}^{td} \geq P_{min,i} \tag{6.16}$$



The elements of the objective function are the costs of primary, secondary, and tertiary reserves provided by resources within areas (they are assumed to be a ratio of quadratic functions of generations cost used in power system studies - cost functions are taken from standard test IEEE grids such as IEEE 24 buses and 39 buses). For the sake of simplicity and due to space limitation, we do not introduce reserve cost functions here (The employed cost functions in this chapter are similar to those which come in the appendix of chapter 7). However,  $C(.)$  in equation (6.4) with whatever indice is a quadratic function of related variable. This function is exclusive for each unit or interconnection and for different reserve types. Even upward and downward services for the same reserve category (primary, secondary, tertiary) are not necessarily identical.

Upward and downward primary reserve needs in DK1 are modeled in (6.5) and (6.6). Equations (6.7) and (6.8) indicate the limitation of contract capacity for primary reserve. Upward and downward secondary reserve needs are modeled in (6.9) and (6.10). Equations (6.11) and (6.12) indicate the limit of Danish-German interconnection for secondary reserve. Similarly, upward and downward tertiary reserve needs are modeled in (6.13) and (6.14). Equations (6.15) and (6.16) guarantee minimum and maximum feasible output power for the thermal power plants and gas turbines within DK1. One may argue that improbable coincidence of primary, secondary, and tertiary reserve undermines the logic in equations (6.15) and (6.16). However, this flaw is rejected as the system operator's call for all kinds of reserve should be in place irrespective of time. The philosophy of binary constants in these equations is that not all kind of thermal units can provide all types of reserves. For instance, only fast online units can provide primary reserve. It should be noted that these are just already known constants and should not be mistakenly misunderstood as binary variables.

As objective function is quadratic and constraints are all linear, the optimization problem is solved using linearly constrained quadratic programming. For this study, YALMIP which is a MATLAB based optimization package<sup>16</sup> is used. The presented formulation gives the share of reserve services by units within DK1 and interconnections with Germany and Norway. Here we investigate the impact of interconnections on reserve procurement cost. The focus is mainly on HVDC interconnections with Norway as it is assumed that it provides DK1 with both primary and tertiary

---

<sup>16</sup>Generally solving the optimization problems in packages such as CVX and YALMIP are user-friendly and easy to implement (The user does not need to have an expert level understanding about the optimization theory). The user needs to formulate the problem in a convex form and then put in the objective function and constraints into programming environment according to the pre-defined syntax.

services. Provision of fast primary service from this line is possible due to forthcoming VSC-based HVDC line named *Skagerrak 4* [15]. German interconnections offers only secondary reserve. The external reserve services are considered to be less expensive than domestic units due to the fact that hydropower-based reserve<sup>17</sup> in Norway has less marginal price in comparison to thermal domestic plants. Table II compares the monthly average of spot price in DK1 and NO2 (a pricing zone in Norway connected to DK1) for the year 2012. It is seen that the energy prices are lower in Norway. The same trend can be inferred of reserve price.

TABLE II. COMPARISON OF ENERGY PRICES IN DK1 AND NO2

Elspot prices in [EUR/MWh]					
	NO2	DK1		NO2	DK1
January	34.95	37.01	July	13.73	25.55
February	44.48	48.35	August	20.63	39.01
March	28.70	31.52	September	18.74	37.40
April	30.22	34.76	October	34.34	38.11
May	26.70	36.06	November	33.97	34.91
June	23.44	37.21	December	40.69	36.86

### 6.3.1 Behavior of reserve procurement cost under different scenarios

Proposed formulation is solved for two different scenarios. In scenario 1 we investigate the impact of increasing primary reserve requirement set by TSO from existing value of  $\pm 27$  MW to  $\pm 40$  MW. At the same time contract capacity for primary reserve on mentioned interconnection increases from 10 MW to 20 MW. Scenario 2 addresses tertiary reserve service. In this scenario, we investigate the impact of tertiary reserve requirement set by TSO from +550 MW for upward regulation to +700 MW and for downward regulation from -210 MW to -266 MW. Similar to the first scenario, contract capacity for tertiary reserve on mentioned interconnection also increases, this time from 100 MW to 150 MW. Three conventional power plants in DK1 are supposed to produce reserve products.  $P_{g,1}$ ,  $P_{g,2}$  and  $P_{g,3}$  are dominant operation points of conventional units.

<sup>17</sup> High controllability, zero-emission rate makes hydropower an excellent source for flexibility against wind power variability. For this reason Danish power system accounts on Norwegian hydropower to a large extend.

Fig. 6.3 and Fig. 6.4 depict the reserve procurement cost behavior in both scenarios. It is observed that increasing the *allowed reserve capacity*<sup>18</sup> by the interconnection decreases the total cost of reserve services as higher share of reserve can be provided by cheaper foreign sources. As the amount of primary reserve in DK1 is relatively low the saving which is gained due to provision of primary reserve on this interconnection is not significant. This amount will certainly increase if we take into account the economic equivalent of reliability level that this interconnection adds to system. However, for tertiary reserve, aforementioned saving is significant which is due to higher need for tertiary reserve in DK1.

The overall economic benefit of the interconnection is certainly dependent on the price of reserve on two sides of the interconnection. The benefit is higher in summer when the cost of reserve provision is low due to sufficiently high level of water reserves of Norwegian side.

Obviously as the required reserve increases, the objective function grows as well (which is observed in both scenarios).

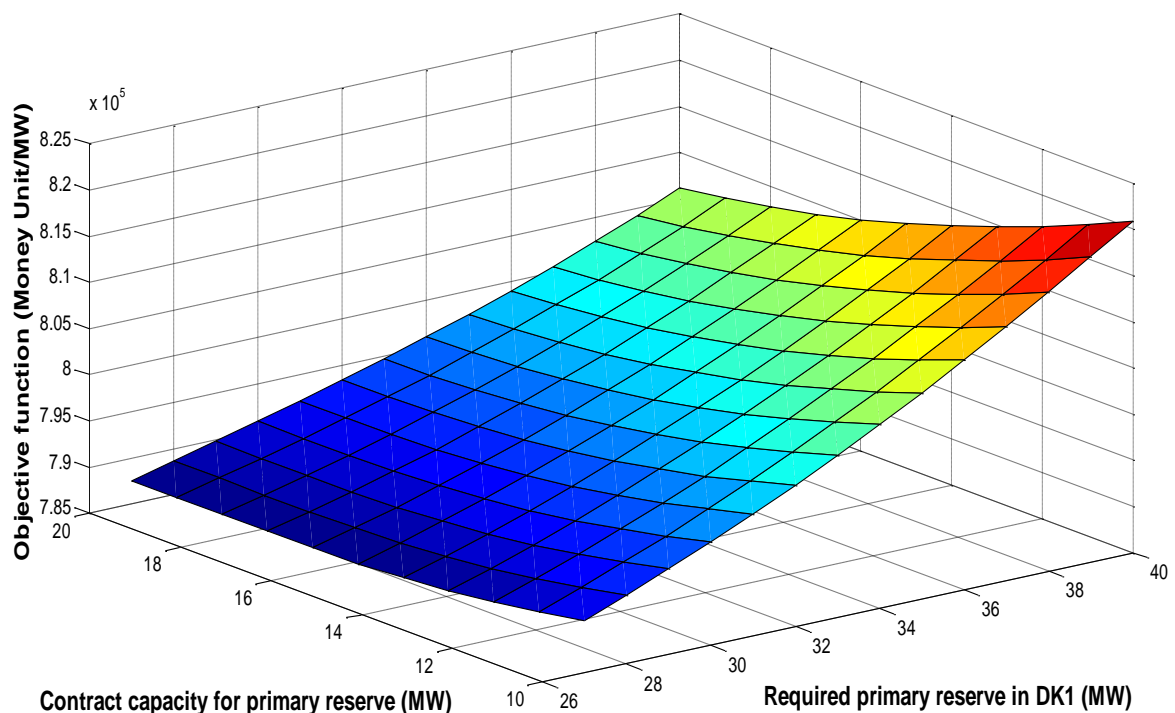

Fig. 6. 3. Reserve procurement cost behavior with changes in primary reserve

<sup>18</sup> The capacity that is dedicated to reserve from interconnections according to the contract between Transmission System Operators of the two countries.

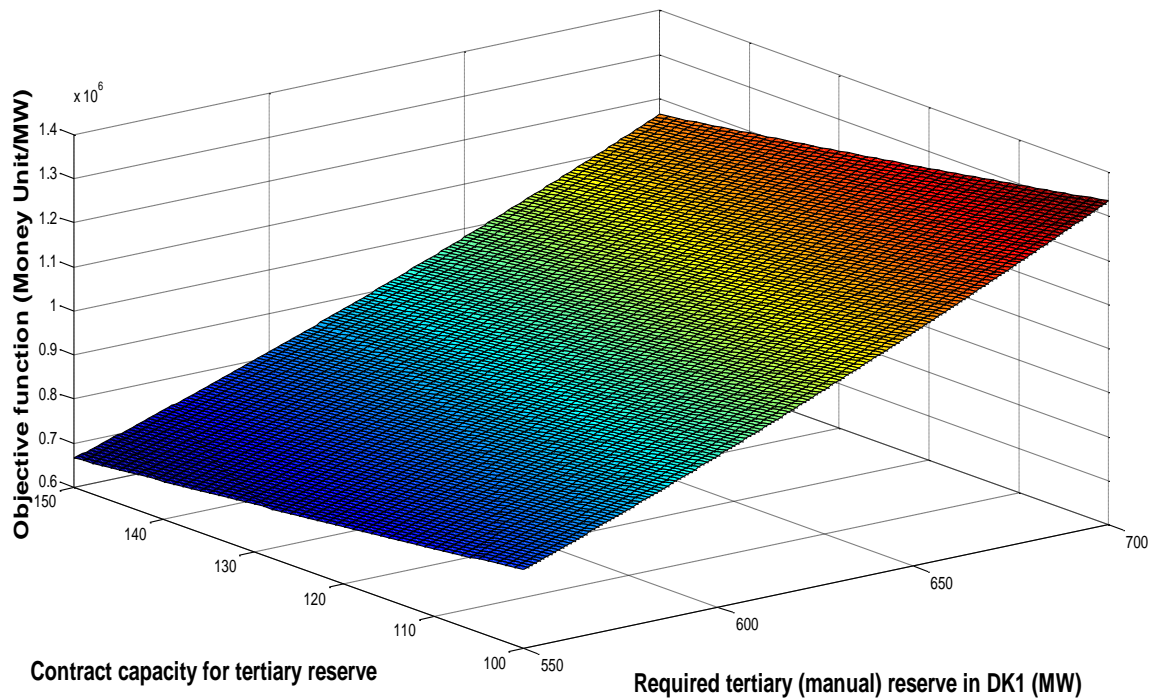

Fig. 6. 4. Reserve procurement cost behavior with changes in tertiary reserve

## 6.4 Summary

The main contribution of this study is to propose an analytical framework to optimally allocate the decoupled share of different types of reserves (namely upward/downward primary, secondary, and tertiary services). The proposed framework takes the reserve costs and physical constraints of system as input and minimizes total reserve procurement cost. This provides the share of conventional power plants for reserve provision within DK1 and cross border interconnections. Results explain the behavior of reserve procurement cost under different scenarios. The role of interconnections is concluded as economically beneficial for reserve provision purposes. This chapter is based on our earlier contribution at [16].

A new VSC-based HVDC interconnection will be commissioned soon. The fast controllability of this interconnection allows western Danish power system to benefit from hydropower resources in Norway as a primary reserve provider. This interconnection is used as the test case.

## References

- [1] A. Ahmadi-Khatir, A. Conejo, R. Cherkaoui, "Multi-Area Energy and Reserve Dispatch Under Wind Uncertainty and Equipment Failures," *IEEE Trans. Power Syst.*, vol.28, no.4, pp.4373,4383, Nov. 2013
- [2] A. Papavasiliou, S. Oren, R. O'Neill, "Reserve Requirements for Wind Power Integration: A Scenario-Based Stochastic Programming Framework," *IEEE Trans. Power Syst.*, vol.26, no.4, pp.2197,2206, Nov. 2011
- [3] J. Morales, A. Conejo, J. Perez-Ruiz, "Economic valuation of reserves in power systems with high penetration of wind power," *Power & Energy Society General Meeting, 2009, PES IEEE* , vol., no., pp.1,1, 26-30 July 2009
- [4] A. Conejo, J. Aguado, "Multi-area coordinated decentralized DC optimal power flow," *IEEE Trans. Power Syst.*, vol.13, no.4, pp.1272,1278, Nov 1998
- [5] F. Galiana, F. Bouffard, J. Arroyo, J. Restrepo, "Scheduling and Pricing of Coupled Energy and Primary, Secondary, and Tertiary Reserves," *Proceedings of the IEEE* , vol.93, no.11, pp.1970,1983, Nov. 2005
- [6] A. Grassi, M. Benini, A. Zani, "A scenario analysis for an optimal pan-European cross-border network development," *Energy Market (EEM), 8th International Conference on the European* , May 2011
- [7] K. De Vos, J. Morbee, J. Driesen, R. Belmans, "Impact of wind power on sizing and allocation of reserve requirements," *Renewable Power Generation, IET* , vol.7, no.1, pp.1,9, February 2013
- [8] A. Ahmadi-Khatir, M. Bozorg, R. Cherkaoui, "Probabilistic Spinning Reserve Provision Model in Multi-Control Zone Power System," *IEEE Trans. Power Syst.*, vol.28, no.3, pp.2819,2829, Aug. 2013
- [9] O. Nilsson, L. Soder, D. Sjelvgren, "Integer modelling of spinning reserve requirements in short term scheduling of hydro systems," *IEEE Trans. Power Syst.*, vol.13, no.3, pp.959,964, Aug 1998
- [10] Energy policy in Denmark", Danish Energy Agency, Dec. 2012.
- [11] Energinet.dk's ancillary services strategy, Energinet.dk, Aug. 2011
- [12] Inputs from Danish TSO.
- [13] Kristoffersen, J.R, "The Horns Rev Wind Farm and the Operational Experience With The Wind Farm Main Controller," *proc. of Copenhagen offshore wind*, Oct, 2005.

- [14] V. Akhmatov, C. Rasmussen, P. E. Eriksen and J. Pedersen, "Technical Aspects of Status and Expected Future Trends for Wind Power in Denmark", *WIND ENERGY*, John Wiley & Sons, Great Britain, Jun. 2006
- [15] T. Haileselassie, "Control, Dynamic and Operation of Multi-terminal VSC-HVDC Transmission System," Ph.D. dissertation, NTNU, 2012.
- [16] F. Astaneh, M.; Rather, Z.H.; Weihao Hu; Zhe Chen, "Economic valuation of reserves on cross border interconnections; A Danish case study," PES General Meeting | Conference & Exposition, 2014 IEEE , pp.1,5, 27-31 July 2014

## Chapter 7

### Reserve scheduling considering environmental impact of reserve providers

Decoupled scheduling of energy and reserve is rebuked due to suboptimality issues. However, for practical reasons it is the common practice in many power systems around the world. In this chapter a model is proposed for successive energy and reserve<sup>19</sup> scheduling considering the emission impact of reserve service providers. For large scale wind integrated power system with displaced conventional generation, wind turbines are also assumed to participate in providing reserve service. Further, Electric Vehicles (EVs) participation in reserve service market is taken into account to demonstrate that EV's environmental impact varies with the variation in penetration level of renewable energy. Results show how the environmental impact of reserve providers modifies the share of different generation technologies in upward and downward reserves.

#### 7.1 Introduction and literature overview

A substantial work addressing the environmental impact of energy and reserve provision is reported in previous literature. In [1] the effect of spinning reserve requirement on emissions is analyzed. The impact of reserve supplying demand response is also incorporated in the problem formulation. The environmental finger print of dispatched units is decoupled into nonlinear functions of  $CO_2$  and  $SO_x$  emission costs. Piecewise linearization technique is then used to incorporate these functions in the problem formulation. Results address the conceptual relationship of reserve scheduling and emission reduction. It is also shown that reserve providing demand response is a powerful tool for emission reduction.

A stochastic multi-objective simultaneous energy and reserve scheduling in a distribution grid with high wind penetration is introduced in [2]. The proposed framework, based on augmented epsilon-constraint method, minimizes operational costs and emissions. The framework generates Pareto-optimal solutions for scheduling energy and reserve considering the uncertainty of wind and demand. In this study demand participates in both energy and reserve markets through a load aggregator party that aggregates offers from medium and large size loads. Simulation results evidenced that inclusion of units' environmental impact modifies the scheduling of reserve and

---

<sup>19</sup> Tertiary reserve

energy in the studied grid.

In [3] a fuel and emission constrained power producer self-schedules by making a compromise between different profit levels and their associated risk level in the day-ahead electricity market. Problem formulation incorporates the uncertainty of electricity and fuel prices. In order to tackle fuel uncertainty, a rolling window framework is proposed. In [4] the unit commitment framework captures voltage security and  $SO_2$  emission constraints simultaneously. Dutch power system with its high share of CHP units and wind power is studied in [5]. The unit commitment and economic dispatch formulations take into account the heat and power demand simultaneously. The conclusion reveals the impact of different penetration levels of wind power on environmental measures.

Regulatory and public policies with regard to environmental impact of power systems are discussed in [6]. The outcome prioritizes the effectiveness of possible solutions for emission reduction. These are emission dispatch, fuel switching, demand side management, and investment in clean energy. In [7] the impact of EU  $CO_2$  emissions trading on Nordic electricity markets is studied. It is shown how this trading can increase the electricity price. A novel heuristic approach is introduced in [8] to solve a reserve constrained economic dispatch problem incorporating emission limitations. The presented formulation is a nonlinear, non-convex, and non-smooth optimization problem that is solved by employing a meta-heuristic algorithm. The quality of the results is compared with other heuristic approaches. Similarly [9] uses a heuristic approach for environmental economic dispatch problem. The presented multi objective particle swarm optimization approach is a slightly different version of conventional PSO<sup>20</sup> that offers more functionality for multi objective purposes. Fuel cost and equivalent environmental impact are considered in the proposed framework. In [10] a robust optimization formulation is presented to give the maximizing bidding curves for a price taker producer participating in a pool where the uncertain parameter is electricity price.

Several papers have considered the environmental benefits of flexible demand programs. In [11] a stochastic algorithm incorporating Markov chain is proposed to benefit from the domestic appliances as Dynamic Demand (DD) for primary frequency regulation. The  $CO_2$  emission per refrigerator is quantified in the study. The analysis considers the potential of wind farms for providing inertia and primary reserve services. The potential achievements of the proposed methodology are significant. A case study in the paper reveals 330 kg carbon emission reduction per year per refrigerator. Simultaneous scheduling of energy and reserve with bounded

---

<sup>20</sup> Particle Swarm Optimization



$CO_2$  emission and consideration of reserve supplying demand response is formulated in [12]. Authors show how reducing allowable  $CO_2$  emission cap changes the reserve scheduling. It is concluded that this reduction limits the commitment level of polluting but inexpensive units in energy market increases their role in reserve market. Authors argue that having larger share of inexpensive units in reserve market will reduce the cost of security in power system. More studies on the impact of demand side participation can be found in [13]-[15].

Considering the environmental benefit of EV participation in competitive electricity markets has been the center of attention in various recent research works. In [16] the participation of an EV aggregator in manual reserve market is explained. The EV aggregator participates in day-ahead energy market and intraday reserve markets. The appealing characteristic of the proposed methodology is to eliminate the need for driving patterns that are usually sensitive data and are not necessarily applicable to all plausible scenarios. Results indicate that EV participation in tertiary reserve market can bring significant cost reduction for aggregator even in market mechanisms with no availability compensation. In [17] a stochastic optimization model is proposed for optimal operation of an EV aggregator in short term energy and regulation market. Day-ahead intraday market variables are incorporated in the problem formulation. The novelty is to consider instructed and uninstructed power deviations. It is shown how considering this intricacy can change the optimal bidding strategy of the aggregator. A novel battery modeling is also introduced which provides comprehensive representation of battery's physical characteristics.

In [18] hourly coordination of electric vehicle operation in security constraint unit commitment is discussed. The stochastic formulation covers the uncertainty of wind energy, load, power system component's contingency rate, and number of available EVs in a fleet. Salient contributions of the paper are incorporating transmission constraints and explain the impact of large EV penetration on the generation profile of thermal power plants. Based on life-cycle cost analysis approach, authors in [19] put forward a model that determines economic and environmental implications of an EV based transport system in US. With an economic approach, rather than a technical one, this study reveals that tax credit has a significant role as an incentive for encouraging people to use electric vehicle. HEV, PHEV15, PHEV35 and EV are the options to make the main body of sustainable transport system and their life-cycle cost is compared to conventional vehicles. In [20] the impact of large scale of gridable EVs typically called gridable vehicles (GVs) on emission rate is introduced. Authors show that large penetration of GV is economically and technically viable.

In [21] a business case providing downward secondary reserve by EVs is analyzed. Unlike some similar studies, this study reveals that EVs are not suitable for provision of backward secondary reserve in German electricity market. The model considers strict specific market regulations for secondary reserve in Germany that calls for a very high degree of availability, real driving patterns and real market data. Heat and electricity demand of a geographical area with EVs is considered in [22]. The emission impact of different dispatch scenarios including EV participation (controlled and uncontrolled charging) is compared. The novelty of this method lies in considering the electricity and heat demand simultaneously and along with their interaction on  $CO_2$  emission impact. The efficiencies of CHP units are also incorporated. Researchers in [23] propose an ICT-controlled plug-in EV for regulation purposes. The paper concludes that three million EVs could satisfy a significant portion of the regulation requirement in California by the end of 2020. Frequency regulation reserve requirement in high wind penetration incorporating minute by minute grid operations and control constraints is examined in [24]. The proposed multi agent stochastic simulator determines up and down regulation requirement in Hydro Québec power system considering different wind penetration scenarios.

In [25], current practices for up and down regulating market in Nordic electricity market is reviewed. Required regulating power services and related prices in Nordic market for three consecutive years from 2008 to 2010 is given. In [26] authors have introduced existing monitoring regulatory procedures of the Nordic regulation power markets. Interaction of power markets and the role of different market actors are classified in Nordic countries. According to this report, upward and downward regulating services are provided by Balance Responsible Parties (BRPs) regardless to if the service is needed in the country itself or other Nordic countries. As an instance regulating services needed in Denmark can be provided by BRPs in Norway.

## **7.2 Model explanation**

As mentioned in the previous section, Danish power system which is a part of Nordic electricity market, has predetermined values for primary, secondary, and tertiary regulation services. For example in the Western Danish power system, up and down primary reserve is +/-27 MW, secondary reserve is +/-90 MW and tertiary (manual) reserve is +540 MW for up regulation and -210 MW for down regulation reserve.

In this study a reserve scheduling methodology is proposed considering the environmental impact of reserve service providers. The proposed reserve scheduling is solved after energy schedules are decided but not realized. The uncertainty in realization of scheduled energy is taken into account using a robust optimization technique. The origin of this uncertainty includes demand forecast error, renewables intermittency and contingencies in power system elements. Robust optimization technique (which is mathematically introduced in the next section) is a conservative approach for optimization under uncertainty. It ignores uncertainty distributions and instead relies only on confidence intervals of uncertain parameters. In our problem formulation, the output power (or energy) of reserve service providers are considered as uncertain parameters. Thus available up and down reserves for all reserve providing units (generation units, EVs, loads that participate in reserve market) vary in accordance to the pre-defined confidence intervals.

As depicted in Fig. 7. 1, the energy is scheduled in the first stage, and then reserve scheduling is done considering the uncertainty in realization of energy schedules. The environmental impacts of reserve providers are quantified incorporating the pollutant cost of different technologies. The proposed formulation minimizes the sum of reserve procurement cost and environmental costs.

It is to be noted that the scope of this study is to incorporate the environmental impact of reserve providing technologies, while relatively more influential environmental impact of energy reserve is not considered as we assume it has already been dealt in energy scheduling stage<sup>21</sup> (power scheduling). Furthermore it is argued that the different reserve resources have their own environmental impact.

It is assumed that the required reserve services are determined by the system operator and sum of reserve provided by committed resources (committed in reserve market) should make those values. Upward and downward reserve costs from different resources vary and are inspired by the current practice in the western Danish power system. Author's expectations and questions in the early stage of this research work were as follows:

- How the share of different reserve participating technologies in upward/downward reserve market will vary by incorporating the environmental impact of participating technology?
- How the consideration of uncertainty in energy scheduling can affect the reserve scheduling?

---

<sup>21</sup> Considering the environmental impact in energy scheduling stage is repeatedly addressed in the literature as mentioned in section 6.1. In this study , the energy is already scheduled (scheduled power set points are given in appendix)

-In an emission based reserve scheduling framework, how different penetration levels of intermittent renewables can affect the commitment share of reserve service providers?  
 -And to decouple the role of upward/downward reserve considering the environmental impact of different technologies.

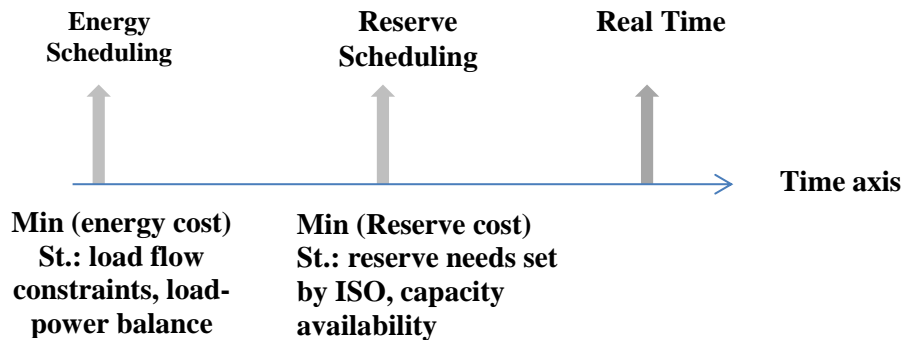

Fig.7.1. Sequential reserve scheduling<sup>22</sup>

### 7.3 Robust optimization

Traditionally, stochastic optimization is the technique to deal uncertainties in power systems. This methodology is widely used in power system applications to consider different uncertainties such as wind power uncertainty, demand uncertainty and the uncertainty in the contingency of system elements. Although stochastic optimization is shown to be a reliable tool for decision making under uncertainty, however there are some evidences that question the functionality of this method. First, in order to be able to use this technique the probability distribution of uncertain variable should be available. This is not feasible in many real life applications as it demands high resolution data. Furthermore the results are highly dependent on the uncertainty distribution in question which is not necessarily accurate. In addition in stochastic optimization scenarios, the plurality of scenarios may simply lead to intractability issues. Due to mentioned drawbacks and also the need for more conservative approaches in some applications the robust optimization technique is introduced [27]-[28]. It deals with optimization problems in which a certain measure of robustness is sought against uncertainty that can be represented as deterministic variability in the value of the parameters of the problem itself and/or its solution. Robust optimization models the random variables as uncertain parameters belonging to a convex uncertainty set where the decision-maker protects the system

<sup>22</sup> The concept which should be inferred from the figure is that energy (power) scheduling and reserve scheduling are done in two separate optimization problems. Energy scheduling is first done and then reserve scheduling will be done considering the uncertainties in realization of energy. (sequentially rather than simultaneously)

against the worst case within that set [28].

In a general setting, robust optimization deals with optimization problems with two sets of variables, decision variables and uncertain variables. The target in deterministic worst-case robust optimization is to find a solution on the decision variables such that the worst-case cost is minimized (or maximized) and the constraints are robustly feasible, when the uncertainty freely takes arbitrary values in a defined uncertainty set. As our problem is linear we adopt the general linear form of a robust optimization problem [29] as defined below.

$$\begin{aligned} & \text{Min } c^T x \\ & \text{Subject to:} \\ & Ax \leq b, \quad \forall a_i \in S_1, \dots, a_i \in S_m \end{aligned}$$

Where  $a_i$  is the  $i^{\text{th}}$  row of the uncertainty matrix  $A$  with its values in the uncertainty set  $S$ . Obviously,  $a_i^T x \leq b_i, \forall a_i \in S_i$ , the inequality is satisfied in all scenarios of the uncertainty set only if it is satisfied with the term in its left hand side in its maximum value as defined below.

$$\max_{\{a_i \in S_i\}} a_i^T x \leq b_i \quad \forall i$$

Following example gives an intuitive understanding about the general concept.

$$\max_{x,y} \{4x + 3y\} \text{ subject to: } x, y \geq 0; ax + by \leq 10, \forall (a, b) \in S \text{ where } S \text{ is a subset of } R^2.$$

What makes this a robust optimization problem is the clause;  $ax + by \leq 10$  in the constraint. Its implication is that for a pair  $(x, y)$  to be permissible, the constraint  $ax + by \leq 10$  must be satisfied by the worst  $(a, b) \in S$  pertaining to  $(x, y)$ , which is  $(a, b) \in S$  that maximizes the value of  $ax + by$  for the given value of  $(x, y)$ .

Another example can be as the following:

*decision variable: x*

*uncertainty set: s=[-0.5,0.5]*

*objective:  $\min -x$*

*constraint:  $x+s \leq 1$*

Obviously, the optimal  $x$  is 0.5, since if  $x$  is larger than 0.5, there exist a  $s$  such that the constraint is violated.

As it will be seen in the next section the decision variables in our study are upward and downward reserves while the uncertain sets are scheduled energy level (For instance one unit is scheduled to produce 50 MW next day, but at the time of reserve scheduling its production is consider to be in the range; [45,55] ). Decision variables (reserve from different sources) come in the objective function and uncertainty sets<sup>23</sup> (the range in which the scheduled power is expected to be realized) come in the constraints. This is the constraint for available capacity for bidding reserve. This is more elaborated in the problem formulation and also in Fig. 7.4 where the available capacity for up/down reserve with and without considering uncertainty is compared.

In this study we have adopted YALMIP (introduced in previous chapters). The inner analytical and computational algorithms within the package will be found in more details in [29]. As in our case the objective function is quadratic with linear constraints (The constraints are affine and constrained to a norm-ball. It is shown in [29] how it typically turns to an efficient and well behaved representation of worst-case scenario).

## **7.4 Problem formulation**

In this part the formulation for reserve scheduling incorporating the environmental impact of reserve providers is presented. The objective function to be minimized consists of two parts, the cost of reserve provision for upward and downward reserve services, and the equivalent environmental cost of each reserve service provider. Considering the nomenclature below, (7.1) gives the objective function:

### *A. Decision Variables*

$r_{th}^u$       *Upward reserve provided by a thermal unit*

$r_{th}^d$       *Downward reserve provided by a thermal unit*

---

<sup>23</sup> Or uncertainty bounds.

$r_g^u$	<i>Upward reserve provided by a gas unit</i>
$r_g^d$	<i>Downward reserve provided by a gas unit</i>
$r_{hy}^u$	<i>Upward reserve provided by a hydro unit</i>
$r_{hy}^d$	<i>Downward reserve provided by a hydro unit</i>
$r_w^u$	<i>Upward reserve provided by a wind unit</i>
$r_w^d$	<i>Downward reserve provided by a wind unit</i>
$r_{EV}^u$	<i>Upward reserve provided by an EV aggregator</i>
$r_{EV}^d$	<i>Downward reserve provided by an EV aggregator</i>
$r_L^u$	<i>Upward reserve provided by a reserve participating load</i>
$r_L^d$	<i>Downward reserve provided by a reserve participating load</i>

### B. Uncertain Parameters(sets)

$p_{th}$	<i>Uncertain scheduled power for thermal unit</i>
$p_g$	<i>Uncertain scheduled power for gas unit</i>
$p_{hy}$	<i>Uncertain scheduled power for hydro unit</i>
$p_w$	<i>Uncertain scheduled power for wind farm</i>
$p_{EV}$	<i>Uncertain scheduled power for electric vehicle</i>
$l$	<i>Uncertain scheduled reserve participating load</i>

### C. Constants

$\mathcal{R}_{th}^u, \mathcal{R}_{th}^d$	<i>Up/down ramp rate for thermal unit</i>
$\mathcal{P}_{th}^{max}, \mathcal{P}_{th}^{min}$	<i>Maximum/Minimum output power for thermal unit</i>
$\mathcal{R}_g^u, \mathcal{R}_g^d$	<i>Up/down ramp rate for gas unit</i>
$\mathcal{P}_g^{max}, \mathcal{P}_g^{min}$	<i>Maximum/Minimum output power for gas unit</i>
$\mathcal{R}_{hy}^u, \mathcal{R}_{hy}^d$	<i>Up/down ramp rate for hydro unit</i>
$\mathcal{P}_{hy}^{max}, \mathcal{P}_{hy}^{min}$	<i>Maximum/Minimum output power for hydro unit</i>
$\mathcal{R}_w^u, \mathcal{R}_w^d$	<i>Up/down ramp rate for wind unit</i>
$\mathcal{P}_w^{max}, \mathcal{P}_w^{min}$	<i>Maximum/Minimum output power for wind farm</i>
$\mathcal{R}_{EV}^u, \mathcal{R}_{EV}^d$	<i>Up/down ramp rate for EV aggregator</i>
$\mathcal{P}_{bat}^{max}$	<i>Maximum capacity of EV aggregator</i>

$l^{max}, l^{min}$	Maximum/Minimum possible loading for reserve participating loads
$\mathcal{R}_{req}^u, \mathcal{R}_{req}^d$	Required upward/downward reserve by system operator
$\mathcal{E}\mathcal{J}_{r,th}^u, \mathcal{E}\mathcal{J}_{r,th}^d$	Upward/Downward environmental indice of thermal unit
$\mathcal{E}\mathcal{J}_{r,g}^u, \mathcal{E}\mathcal{J}_{r,g}^d$	Upward/Downward environmental indice of gas unit
$\mathcal{E}\mathcal{J}_{r,EV}^u, \mathcal{E}\mathcal{J}_{r,EV}^d$	Upward/Downward environmental indice of EV aggregator
$\mathcal{E}\mathcal{J}_{r,L}^u, \mathcal{E}\mathcal{J}_{r,L}^d$	Upward/Downward environmental indice of load

$$\begin{aligned}
\text{Min} \left( \sum r_{th}^u c_{r,th}^u + \sum r_{th}^d c_{r,th}^d + \sum r_g^u c_{r,g}^u + \sum r_g^d c_{r,g}^d + \sum r_{hy}^u c_{r,hy}^u \right. & (7.1) \\
& + \sum r_{hy}^d c_{r,hy}^d + \sum r_w^u c_{r,w}^u + \sum r_w^d c_{r,w}^d + \sum r_{EV}^u c_{r,EV}^u \\
& + \sum r_{EV}^d c_{r,EV}^d + \sum r_L^u c_{r,L}^u + \sum r_L^d c_{r,L}^d) \\
& + \left( \sum r_{th}^u \mathcal{E}\mathcal{J}_{r,th}^u + \sum r_{th}^d \mathcal{E}\mathcal{J}_{r,th}^d + \sum r_g^u \mathcal{E}\mathcal{J}_{r,g}^u + \sum r_g^d \mathcal{E}\mathcal{J}_{r,g}^d \right. \\
& \left. + \sum r_{EV}^u \mathcal{E}\mathcal{J}_{r,EV}^u + \sum r_{EV}^d \mathcal{E}\mathcal{J}_{r,EV}^d + \sum r_L^u \mathcal{E}\mathcal{J}_{r,L}^u + \sum r_L^d \mathcal{E}\mathcal{J}_{r,L}^d \right)
\end{aligned}$$

The terms in the first parentheses (the first three lines of the objective function) form the direct cost of reserve provision. Similarly the terms in the second parentheses (4<sup>th</sup> and 5<sup>th</sup> line in the objective function) form the environmental impact of the reserve provider units, hereafter called objective\_1 and objective\_2 respectively.

It should be noted that in this formulation, the environmental impact of upward regulation reserve are positive values and are algebraically greater for a more polluting generation technology. Having similar approach in mind, the emission impact of downward reserve are negative values and larger in absolute value for a higher polluting technology.

This is intuitively explainable as by allocating such values, the merit order logic of the optimization framework calls highest polluting agents first for downward regulation and last for upward regulation. The proposed methodology implies zero environmental impact indices for renewables. Thus in a merit order basis they are committed first for upward regulation reserve (zero wins competing with positive values in a minimization problem). Similarly they are committed last for downward regulation reserve (zero loses competing with negative values in a minimization problem) which in turn allows more participation from high polluting technologies in downward



reserve service. Renewables have zero environmental (emission) cost and thus they are not presented in objective\_2.

The introduced objective function is constrained to upward and downward ramp rate of reserve providers and also the capacity availability (capacity availability of thermal, gas, hydro, wind, EV aggregator, and reserve participating loads). These constraints are given in (7.2)-(7.18). Equations (7.19) and (7.20) ensure the upward and downward reserve requirements declared by the system operator. The indices of service providers within the same technology set are not included in the formulation for brevity. All variables are non-negative.

$$r_{th}^u \leq \mathcal{R}_{th}^u, -r_{th}^d \geq \mathcal{R}_{th}^d \quad (7.2)$$

$$p_{th} + r_{th}^u \leq \mathcal{P}_{th}^{max} \quad (7.3)$$

$$p_{th} - r_{th}^d \geq \mathcal{P}_{th}^{min} \quad (7.4)$$

$$r_g^u \leq \mathcal{R}_g^u, -r_g^d \geq \mathcal{R}_g^d \quad (7.5)$$

$$p_g + r_g^u \leq \mathcal{P}_g^{max} \quad (7.6)$$

$$p_g - r_g^d \geq \mathcal{P}_g^{min} \quad (7.7)$$

$$r_{hy}^u \leq \mathcal{R}_{hy}^u, -r_{hy}^d \geq \mathcal{R}_{hy}^d \quad (7.8)$$

$$p_{hy} + r_{hy}^u \leq \mathcal{P}_{hy}^{max} \quad (7.9)$$

$$p_{hy} - r_{hy}^d \geq \mathcal{P}_{hy}^{min} \quad (7.10)$$

$$r_w^u \leq \mathcal{R}_w^u, -r_w^d \geq \mathcal{R}_w^d \quad (7.11)$$

$$p_w + r_w^u \leq \mathcal{P}_w^{max} \quad (7.12)$$

$$p_w - r_w^d \geq \mathcal{P}_w^{min} \quad (7.13)$$

$$r_{EV}^u \leq \mathcal{R}_{EV}^u, -r_{EV}^d \geq \mathcal{R}_{EV}^d \quad (7.14)$$

$$p_{EV} + r_{EV}^u \leq \mathcal{P}_{bat}^{max} \quad (7.15)$$

$$p_{EV} - r_{EV}^d \geq 0 \quad (7.16)$$

$$l + r_L^u \leq l^{max} \quad (7.17)$$

$$l - r_L^d \geq l^{min} \quad (7.18)$$

$$r_{th}^u + r_g^u + r_{hy}^u + r_w^u + r_{EV}^u + r_L^u \geq \mathcal{R}_{req}^u \quad (7.19)$$

$$-r_{th}^d - r_g^d - r_h^d - r_w^d - r_{EV}^d - r_L^d \leq \mathcal{R}_{req}^d \quad (7.20)$$

Available capacity for reserve from an individual participating unit is subjected to uncertainty due

to uncertainty in realization of already scheduled power (energy). The uncertainty around the scheduled level for generation units, EVs, and loads is incorporated by considering confidence intervals (uncertainty intervals-see appendix *B*). These confidence intervals can be different in size incorporating the historical preciseness of related resources. For instance the uncertainty interval is expected to be smaller for thermal units in comparison to the wind farms or EV fleets (as there is less uncertainty in the operation of power plants). As a result, scheduled power level of generating unit, EVs, and loads in mentioned equations are assumed to be in an uncertain range.

With regard to (7.19) and (7.20) it should be noted that upward regulation relates to deficit scenarios where system operator calls for an increase in power generation or decrease in demand. For downward regulation it is vice versa meaning that power system is in surplus condition and needs increase in demand or/and decrease in generation.

Two points should be mentioned about the participation of EV in reserve market. First, in this formulation the reserve services are provided by EV aggregator. Second, the penetration level of EVs is considered to be high in the studied case. This is inspired by the western Danish power system which plans to have significant penetration level of plugin EVs to smooth high variations in generation side. This supports the assumption that EVs are quite likely to be available at all times. On the other hand by assuming the EV-based reserve coming from an aggregator, the state of the charge of the battery is not a constraint because it is dealt as an internal allocation problem of aggregator (allocation among different EV fleets). Upward and downward regulation services can be also provided by reserve participating loads. These may be aggregators or large size consumers such as industrial complexes with relatively high demand.

As mentioned before, the introduced reserve scheduling problem is solved before real time of operation and objective\_1 only considers the availability compensation. The compensation for possible activation (energy) is settled after real time operation.

## 7.5 Simulation results

The simulation is presented into two parts. In the first part wind farms do not participate in the reserve market and the reserve providing units are thermal<sup>24</sup>, gas, hydro, EV aggregator and loads.

---

<sup>24</sup> This is a coal fired steam plant.

The second case assumes that wind power also participates in the reserve market. The costs of  $CO_2$  emission for different technologies are gathered from [30]-[32]. The emission impact of participation of EV aggregator in the reserve market is certainly affected by the generation resources that have contributed to charge the EVs. As the penetration of renewables increase, it is a rational assumption to consider that the higher share of stored energy comes from renewables. Renewable Integration Ratio ( $RIR$ ) gives the electric energy provided by renewables over total produced electric energy (Around 35% in Denmark). Defining  $RIR$ , the environmental impact of renewables is modeled as follows:

$$\mathcal{E}J_{r,EV}^u = (1 - RIR) \mathcal{E}J_{r,ave}^u \quad (7.21)$$

$$\mathcal{E}J_{r,EV}^d = (1 - RIR) \mathcal{E}J_{r,ave}^d \quad (7.22)$$

$\mathcal{E}J_{r,ave}^u$  and  $\mathcal{E}J_{r,ave}^d$  are upward/downward average environmental impact of other reserve provider units. This equation implies that in higher renewable penetration, the polluting impact of reserve provided by EV aggregator is alleviated. In other words, EVs have memory which makes them capable of storing the clean energy (in a power system which its dominant power production portfolio comes from fossil fuel based plants, the EV may not be a sustainable solution). In the second part of this section wind power is considered as a reserve service provider and the impact of different wind penetration levels being investigated. Reserve activation rate is considered to be 0.1 which means that reserve services are called to action in 10% of the times that they are accepted in the reserve market. This coefficient makes the consideration of emission rate for reserve service providers more realistic. Reserve providers are paid for both upward and downward regulating services. This is true in most electricity markets, although downward reserve providers are paid relatively lower than upward reserve providers. It is assumed that this amount is fixed by the market operator and is the same for all reserve providers.

### 7.5.1 Case-I: Without participation of wind farms in reserve service

As mentioned earlier, in case-I wind farms are not considered to provide reserve, instead only thermal, gas, hydro, EV aggregator and loads are assumed to participate in the reserve market.

Two system operating points is being investigated here (shown in appendix A). These operating

condition scenarios are the dominant operating points and thus chosen to be studied. For each operating points, two scenarios are compared; with ( $SC_1$ ) and without ( $SC_2$ ) considering environmental impact. In order to neglect the impact of environmental impact, the objective\_2 is eliminated. Environmental impact of units and cost functions of reserve are given in the appendix. Table I depicts the reserve scheduling optimization outcome for two operating conditions. It can be observed that considering the environmental impact into the objective function modifies the reserve scheduling outcome in a way that; the share of polluting units in downward regulation reserve increases significantly. The share of units in upward regulation reserve is not significantly affected (although there is a tendency to a decrease in the share of polluting units and an increase in the share of renewables. More specifically it is observed that downward reserve provided by more polluting units is increased when taking the environmental impact into account. Likewise, when considering the environmental impact, downward reserve from hydro power is decreased (considering its zero environmental impact) and increased for polluting units. It can also be observed that the general trend is violated in a few specific conditions, the reason is that the decrease in the objective function due to consideration of environmental impact is not sufficient to overcome low price of a polluting function. The required upward and downward reserves are assumed to be 150 MW.

Table I. Comparison of reserve share by different generation technologies

Parameter (MW)	Operating condition 1		Operating condition 2	
	SC1	SC2	SC1	SC2
$r_{th}^u$	50	50	8	8
$r_{th}^d$	30	30	30	50
$r_g^u$	13.3	12.74	34	34
$r_g^d$	12.73	14	30	34
$r_{hy}^u$	50	50	50	50
$r_{hy}^d$	71.26	30	30	0
$r_{EV}^u$	18.34	18.62	18	18
$r_{EV}^d$	24.52	21.53	30	45.11
$r_L^u$	18.34	18.62	40	40
$r_L^d$	0	30	30	39.99

Fig. 7.2 and Fig. 7.3 show the upward and downward reserve services by EVs in different renewable integration ratios ( $RIR$ ). As the integration ratio grows, the environmental cost of EV

decreases and it acts similar to a low emission reserve provider. Therefore EV aggregator is more likely to have a lower/higher share of downward/upward reserve. It can be perceived from mentioned figures that as the integration percentage of renewables grows, there will be significant decrease of downward reserve and gentle increase in upward reserve.

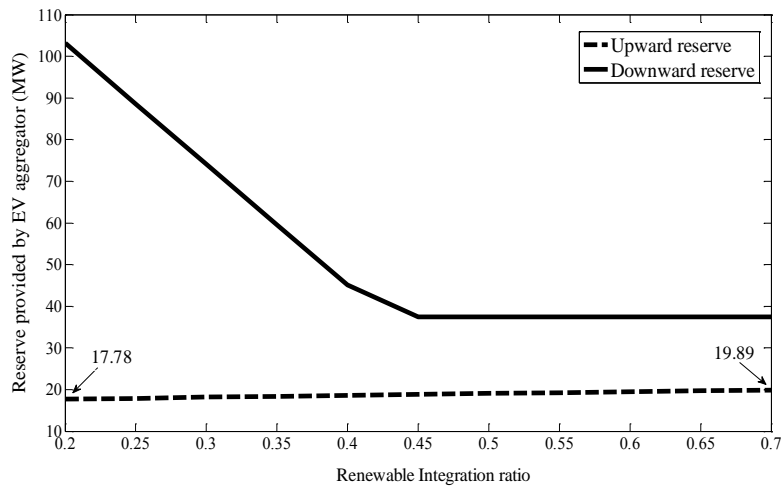

Fig. 7.2. Upward/Downward reserve provided by EV aggregator (operation condition 1)

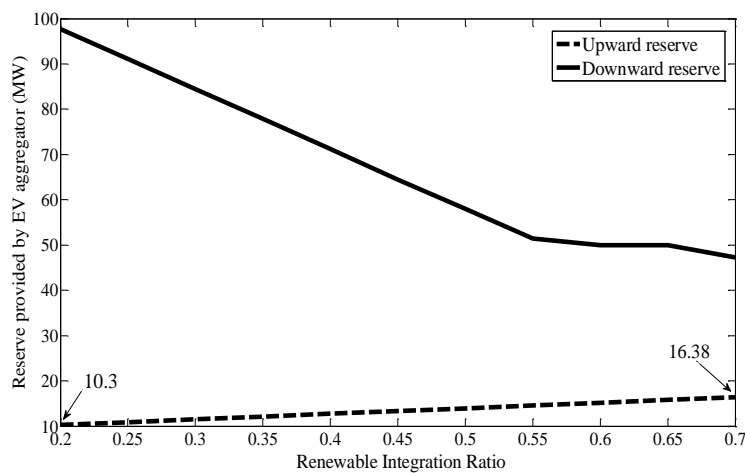

Fig. 7.3. Upward/Downward reserve provided by EV aggregator (operation condition 2)

It is important to discuss how considering uncertainty of the energy scheduling affects the scheduling of reserve. Robust optimization considers an interval of uncertainty around the scheduled point in a given power and a given unit. Considering the uncertainty set (interval), the

available capacity for both upward and downward reserve is reduced<sup>25</sup> (Please see Fig. 7.4). Hence less expensive generators do not provide all their available capacity to reserve market and keep some for handling the uncertainty in energy realization. Therefore in a market framework with certain amounts for upward and downward reserve, this shortage is provided by more expensive units. This increases reserve procurement cost. This is the expense that system operator should pay for gaining more security against uncertainty (uncertainty in the realization of energy schedules). Fig. 7.5 compares reserve procurement cost with and without considering uncertainty in the problem formulation around the point of normal operation of the system (for instance 1.1 in x- axis means 10% higher than unit's normal operating condition). Proposed optimization problem may experience infeasibility when the units are working close to their maximum capacity which physically means that there is no enough capacity to provided demanded reserve. This situation is deteriorated if uncertainty is considered.

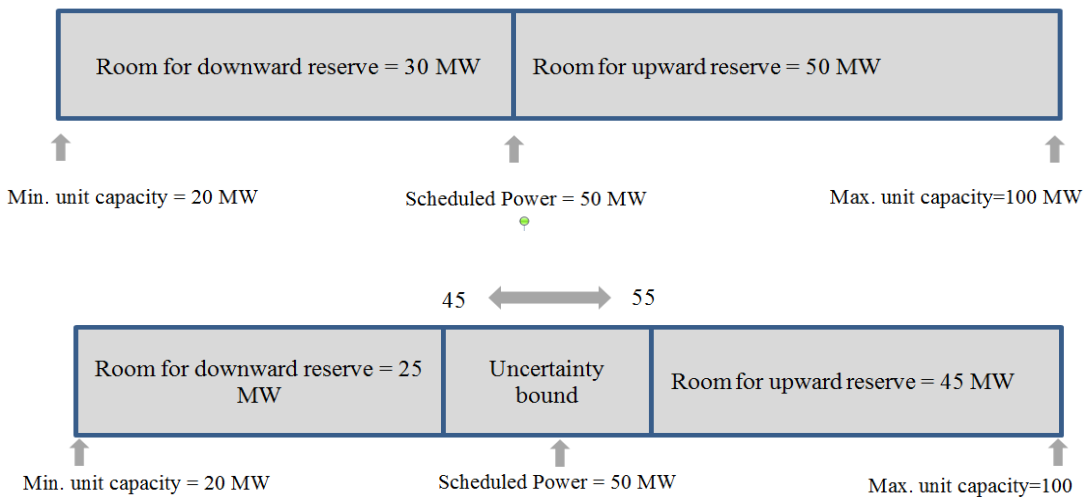

Fig. 7.4. Comparing the available capacity for up/down reserve with and without considering uncertainty

<sup>25</sup> The example in Fig. 7.4 shows that considering uncertainty decreased the capacity for offering upward reserve from 30 MW to 25 MW. Similarly the capacity for offering downward reserve is decreased from 50 to 45 MW.

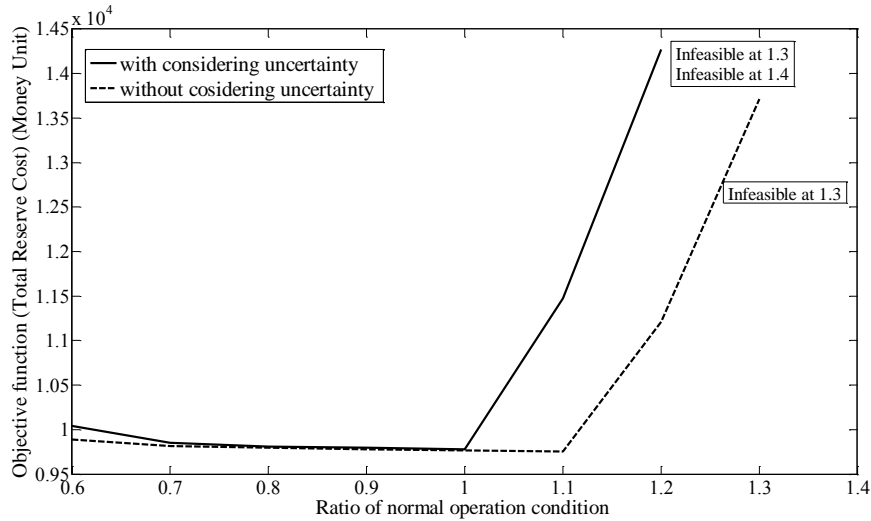

Fig. 7.5. Impact of considering uncertainty on reserve procurement cost

Robust optimization option in YALMIP is used in this study. As mentioned before, YALMIP is a MATLAB-based optimization package. The ordinary and uncertain variables are defined in the YALMIP environment. Upward and downward reserve costs are considered to be a certain coefficients from the generation costs. Typical generation costs for different technologies are taken from MATPOWER introduced in previous chapters.

### 7.5.2 Case-II: With participation of wind farms in reserve service

Renewable energy especially wind and solar power are integrated rapidly to power systems at tremendous pace, driven mainly by the pressure to reduce carbon emission and dependence on fossil fuels. Large scale wind energy integration demands that wind energy should be manageable and controllable much similar to conventional generation. On the other hand progressive displacement of conventional generation due to wind generation is already being experienced in various power systems and is seen inevitable with large scale wind energy integration. This also means that with increased wind energy penetration, ancillary services support like reserve services that are currently offered by conventional generation should also be adequately provided by wind generation in a reliable way. Therefore in this section wind turbines especially wind farms connected at transmission system voltage level are considered to participate in reserve market.

Operational model of the western Danish power system has been selected as the test system. Power system data for the western Danish power system is provided by Danish TSO, Energinet.dk. Since

the test system considered here is the western Danish power system, three major operational wind farms (type-3 wind turbine based Horns Rev-A, type-4 wind turbine based Horns Rev-B and recently commissioned type-4 based Anholt) are assumed to participate in the reserve market. As mentioned before, two scenarios, scenario 1 ( $SC_1$ ) and scenario 2 ( $SC_2$ ) are considered here. Environmental impact of reserve scheduling is considered in  $SC_1$ , however  $SC_2$  does not account for environmental impact of reserves. During the study under investigation, optimal reserve scheduling is evaluated over exhaustive range of operating conditions with wide range of generation technology combinations. Fig. 7.6 shows the objective function representing total cost of reserve procurement for  $SC_1$  and  $SC_2$  with various generation scenarios of thermal and wind power. Both thermal and wind generation is varied from 0 to 75% of total generation and their flexibility of participation in reserve service varies accordingly. Environmental impact on reserve procurement cost can be observed by comparing surfaces of  $SC_1$  and  $SC_2$ . It can be observed that in both scenarios, the overall reserve procurement cost varies from highest value with least share of wind generation to least with highest share of wind generation.

The proportion of upward reserve contributed from thermal units also increases till certain point beyond which any additional increase of thermal generation does not minimize the overall reserve procurement cost. Furthermore, the impact of environmental consideration can be observed by comparison of  $SC_1$  and  $SC_2$  surfaces.

For all operating conditions with wind generation, the reserve procurement cost for  $SC_1$  is lower than that for  $SC_2$ . The reason should be perceived in the second parenthesis in the objective function which indicates the environmental impact. This parenthesis has negative values in all conditions as the environmental impacts of the technologies are all negative (except wind and hydro which have zero environmental impact and thus not mentioned there). This can be observed in Fig. 7.6.

Reserve procurement cost has its highest value when the share of thermal and wind generation is minimum. The reason is that these conditions, major share of reserve is provided by load and other generation sources like gas turbines and EVs.

Fig. 7.7 shows upward reserve scheduling from thermal units under various generation shares of thermal and wind power. As expected the share of upward reserve from thermal units decreases with the increase in wind energy generation. With no wind generation, the upward thermal reserve share increases as thermal generation share grows. This continues till a saturation point beyond



which major share of upward reserve is provided by thermal generation and any further increase in upward reserve share from thermal generation does not further reduce the reserve cost under given operation condition as can be seen in Fig. 7.7. For  $SC_1$ , upward reserve share from thermal units decreases at more steep rate compared to  $SC_2$ . This is due to the fact that in  $SC_1$ , both environmental impact and less reserve cost from wind turbines attract wind power to participate in upward regulation.

Fig. 7.8 shows the objective function representing total cost of reserve procurement for  $SC_1$  and  $SC_2$  considering various generation scenarios of thermal and hydro. Both thermal and hydro generation is varied from 0 to 75% of total generation. It can be observed that under all operating conditions, the total reserve procurement cost for  $SC_1$  is lower than that of  $SC_2$ . It should be noticed that by considering environmental impact, upward regulation from thermal units is discouraged while downward regulation is encouraged. This figure also shows that procurement cost is least for adequate combination of thermal and hydro. The reason is that for adequate generation mix, downward regulation is offered by thermal generating units and in contrast upward regulation is offered by hydro units. Downward regulation by thermal units reduces the reserve procurement cost in two ways; first, environmental impact and second, relatively less cost incurred to accommodate downward regulation as compared to hydro.

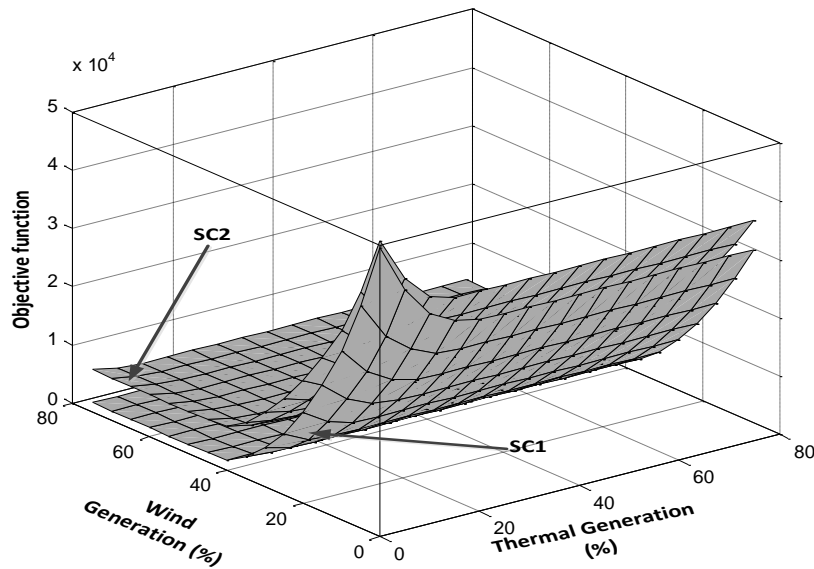

Fig. 7.6. Reserve procurement cost for  $SC_1$  and  $SC_2$  for different generation mix of thermal and wind power

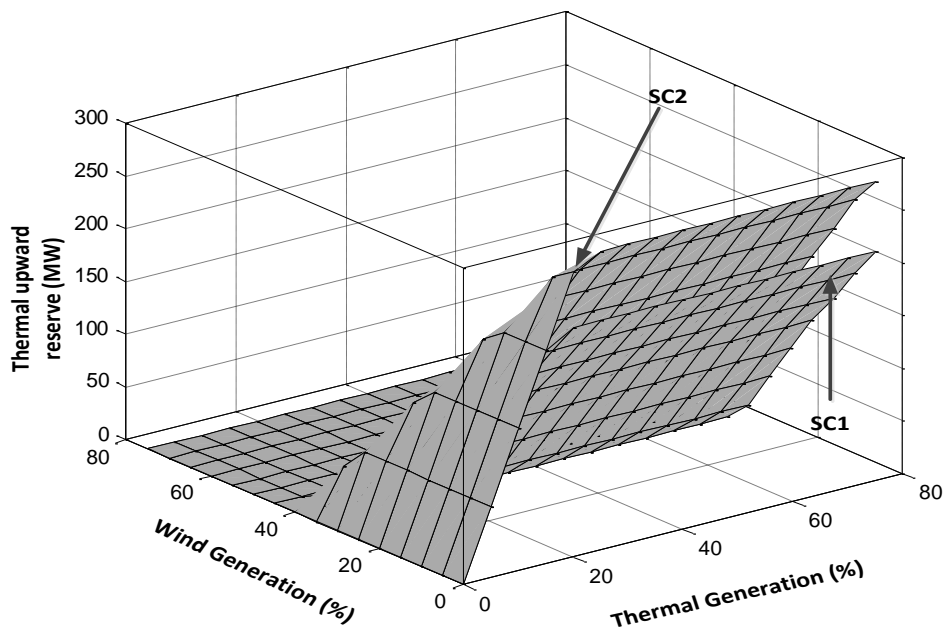

Fig. 7.7. Thermal upward reserve scheduling for  $SC_1$  and  $SC_2$  for different generation mix of thermal and wind power

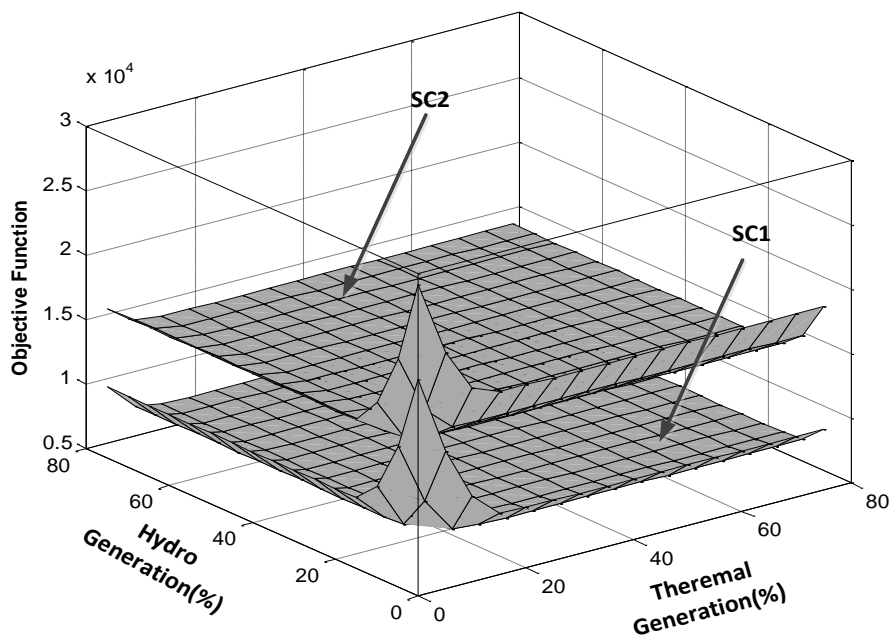

Fig. 7.8. Reserve procurement cost for  $SC_1$  and  $SC_2$  for different generation mix of thermal and hydro power

## 7.6 Summary

The main contributions and findings of this study are:

- 1- A mathematical framework is proposed to decouple upward and downward regulation reserve in a market framework with exogenous reserve requirement regulations.
- 2- It is shown that consideration of environmental impact of reserve resources can modify the reserve scheduling outcome.
- 3- Simulations corroborate that considering the environmental impact of reserve resources causes up- regulating reserve to be provided by renewables and less polluting generation units while down-regulating reserve to be provided by most polluting resources.
- 4- A robust optimization framework is presented to incorporate the uncertainty of ex-stage energy scheduling. Intermittency in renewable resources is incorporated with larger confidence intervals.

## Chapter's Appendix:

### A. Operation points

	<i>Thermal Unit (MW)</i>	<i>Gas Unit (MW)</i>	<i>Hydro unit (MW)</i>	<i>EV aggregator (MW)</i>	<i>Reserve Participating Load (MW)</i>
OC.1	220	60	190	60	100
OC.2	170	100	220	30	100

### B. Uncertainty intervals

	<i>Uncertainty interval percentage</i>	<i>Interval in OC.1(MW)</i>	<i>Interval in OC. 2(MW)</i>
<i>Thermal Unit</i>	5%	[209,231]	[161.5,178.5]
<i>Gas Unit</i>	5%	[57,63]	[95,105]
<i>Hydro Unit</i>	5%	[180.5,168]	[209,231]
<i>EV aggregator</i>	20%	[48,72]	[24,36]
<i>Load</i>	10%	[90,110]	[90,110]

### C. Environmental impact (cost) of different reserve providing sources (Money Unit/MWh)[30]-[31]: (Renewable Integration Ratio= 35%)

	<i>Coal-fired Thermal Unit</i>	<i>Gas Unit</i>	<i>EV aggregator</i>	<i>Load</i>
<i>Environmental impact</i>	21.7	15	(1-RIR)*22.5	(1-RIR)*22.5

### D. Reserve cost functions(Money Unit/MWh)

	<i>Upward reserve</i>	<i>Downward reserve</i>
<i>Thermal Unit</i>	$C_{up}(P)=.08533P^2 + 22P$	$C_{dn}(P)=.00775P^2 + 2P$
<i>Gas Unit</i>	$C_{up}(P)=.28271P^2 + 60P$	$C_{dn}(P)=.02325 P^2 + 6P$
<i>Hydro Unit</i>	$C_{up}(P)=.07509P^2 + 17.6P$	$C_{dn}(P)=.00682 P^2 + 1.6P$
<i>Electric Vehicle</i>	$C_{up}(P)=.29864P^2 + 77P$	$C_{dn}(P)=.27149 P^2 + 7P$
<i>Load</i>	$C_{up}(P)=.29864P^2 + 77P$	$C_{dn}(P)=.27149 P^2 + 7P$
<i>Wind</i>	$C_{up}(P)= P$	$C_{dn}(P)= P$

## References

- [1] M. Behrangrad, H. Sugihara, and T. Funaki, "Effect of optimal spinning reserve requirement on system pollution emission considering reserve supplying demand response in the electricity market," *Appl. Energy*, vol. 88, pp. 2548–2558, 2011.
- [2] V. Vahidinasab and S. Jadid, "Stochastic multi objective self-scheduling of a power producer in joint energy and reserves markets," *Electr. Power Syst. Res.*, vol. 80, pp. 760–769, 2010.
- [3] S. J. Kazempour and M. P. Moghaddam, "Risk-constrained self-scheduling of a fuel and emission constrained power producer using rolling window procedure," *Int. J. Electr. Power Energy Syst.*, vol. 33, pp. 359–368, 2011.
- [4] Z. Li and M. Shahidehpour, "Generation Scheduling with Thermal Stress Constraints," *IEEE Trans. Power Syst.*, vol. 18, pp. 1402–1409, 2003.
- [5] B. C. Ummels, M. Gibescu, E. Pelgrum, W. L. Kling, and A. J. Brand, "Impacts of wind power on thermal generation unit commitment and dispatch," *IEEE Trans. Energy Convers.*, vol. 22, pp. 44–51, 2007.
- [6] B. F. Hobbs and P. Centolella, "Environmental policies and their effects on utility planning and operations," *Energy*, vol. 20, pp. 255–271, 1995.
- [7] M. Kara, S. Syri, A. Lehtilä, S. Helynen, V. Kekkonen, M. Ruska, and J. Forsström, "The impacts of EU CO<sub>2</sub> emissions trading on electricity markets and electricity consumers in Finland," *Energy Econ.*, vol. 30, pp. 193–211, 2008.
- [8] T. Niknam, R. Azizipanah-Abarghooee, and A. Roosta, "Reserve constrained dynamic economic dispatch: A new fast self-adaptive modified firefly algorithm," *IEEE Syst. J.*, vol. 6, pp. 635–646, 2012.
- [9] M. A. Abido, "Multiobjective particle swarm optimization for environmental/economic dispatch problem," *Electr. Power Energy Syst.*, vol. 79, pp. 1105–1113, 2009.
- [10] L. Baringo and A. J. Conejo, "Offering strategy via robust optimization," *IEEE Trans. Power Syst.*, vol. 26, pp. 1418–1425, 2011.
- [11] M. Aunedi, P. Aristidis Kountouriotis, J. E. Ortega Calderon, D. Angeli, and G. Strbac, "Economic and environmental benefits of dynamic demand in providing frequency regulation," *IEEE Trans. Smart Grid*, vol. 4, pp. 2036–2048, 2013.
- [12] M. Behrangrad, H. Sugihara, and T. Funaki, "Effect of demand response resources on optimal spinning reserve procurement in consideration of CO<sub>2</sub> emission," *Univ. Power Eng. Conf. (UPEC)*, 2010 45th Int., 2010.
- [13] P. del Río González and F. Hernández, "How do energy & environmental policy goals and instruments affect electricity demand? A framework for the analysis," *Renewable and Sustainable Energy Reviews*, vol. 11, pp. 2006–2031, 2007.
- [14] G. Keith, B. Biewald, D. White, M. Drunisc, "Modeling Demand Response and Air Emissions in New England", Synapse Energy Economics 2010.

- [15] K.Furusawa, K.Yanase, H.Sugihara, K.Tsuji "A cooperation with customer-side cogeneration systems for power flow congestion relief and its environmental impact", *IEEE PES general meeting*, 2006.
- [16] R. J. Bessa and M. A. Matos, "Optimization models for EV aggregator participation in a manual reserve market, " *IEEE Trans. Power Syst.*, vol. 28, pp. 3085–3095, 2013.
- [17] S. I. Vagropoulos and A. G. Bakirtzis, "Optimal bidding strategy for electric vehicle aggregators in electricity markets, " *IEEE Trans. Power Syst.*, vol. 28, pp. 4031–4041, 2013.
- [18] M. E. Khodayar, L. Wu, and M. Shahidehpour, "Hourly coordination of electric vehicle operation and volatile wind power generation in SCUC, " *IEEE Trans. Smart Grid*, vol. 3, pp. 1271–1279, 2012.
- [19] H.-K. Tseng, J. S. Wu, and X. Liu, "Affordability of electric vehicles for a sustainable transport system: An economic and environmental analysis, " *Energy Policy*, vol. 61, pp. 441–447, 2013.
- [20] A. Y. Saber and G. K. Venayagamoorthy, "Plug-in vehicles and renewable energy sources for cost and emission reductions, " *IEEE Trans. Ind. Electron.*, vol. 58, pp. 1229–1238, 2011.
- [21] Anne Sjoerd Brouwer, Takeshi Kuramochi, Machteld van den Broek, André Faaij, "Fulfilling the electricity demand of electric vehicles in the long term future: An evaluation of centralized and decentralized power supply systems", *Applied Energy*, Volume 107, July 2013, Pages 33-51, ISSN 0306-2619.
- [23] C. Goebel and D. S. Callaway, "Using ICT-controlled plug-in electric vehicles to supply grid regulation in California at different renewable integration levels, " *IEEE Trans. Smart Grid*, vol. 4, pp. 729–740, 2013.
- [24] M. De Montigny, A. Heniche, I. Kamwa, L. Cauchon, R. Mailhot, S. Lebeau, D. Lefebvre, and L. Bernier, "Multiagent stochastic simulation of minute-to-minute grid operations and control to integrate wind generation under AC power flow constraints, " *IEEE Trans. Sustain. Energy*, vol. 4, pp. 619–629, 2013.
- [25] C. Bang, F. Fock, M. Togeby, "The existing Nordic regulating power market", FlexPower WP1 – Report 1, May 2012.
- [26] NordReg, "Monitoring of the Nordic Regulation Power Market", 2007.
- [27] Bertsimas, D.; Litvinov, E.; Sun, X.A.; Jinye Zhao; Tongxin Zheng, "Adaptive Robust Optimization for the Security Constrained Unit Commitment Problem," *Power Syst., IEEE Trans. on* , vol.28, no.1, pp.52,63, Feb. 2013.
- [28] Dimitris Bertsimas, David B. Brown, Constantine Caramanis, "Theory and applications of Robust Optimization", Massachusetts Institute of Technology 2009.
- [29] J. Löfberg. "Automatic Robust Convex Programming. Optimization Methods and Software, " 27(1), 2012.
- [30] "Electric Generation Efficiency: Working Document of the NPC Global Oil & Gas Study". Highbeam Research. Retrieved 18 July 2007.

[31] Peter Lang, "CO2 abatement cost with electricity generation option in Australia", Technical Report, November 2012.

[32] The Electric Power Research Institute (EPRI, 2010) report, available online:  
<http://www.ret.gov.au/energy/Documents/AEGTC%202010.pdf>

## Chapter 8

### Conclusion Remarks and Future Work

Energy authorities in many parts of the world have come to this conclusion that using renewable sources is the most sustainable way of producing electricity [1]. Wind power is the most rapidly developed among renewable energy resources. Beside many advantages, wind is an intermittent source of energy and is not precisely predictable. Thus power systems with significant wind power penetration should enhance their flexibility levels to be able to contain generation-consumption balance. Load-generation imbalance distorts system's frequency and can cause partial or total outages. Balancing the consumption and production of electricity can be addressed in different time frames. For instance the regulations in power industry which encourage investment on generation and transmission expansions enhance power system flexibility in long term. In other words, the conventional regulations in power systems with traditionally robust central power plants should be revised to be adapted to the power production sources which are to a high extent unpredictable.

Balancing generation-demand in power system operation is another crucial subject that is closely looked into in power system studies. The time frame for flexibility here are from milliseconds to some hours. In this time frame, power system flexibility tools are the technologies and operational procedures that can enhance system frequency close to real time. For instance activation of demand response or using storage units to tackle the fast variability of generation side.

Research on the following categories can address enhanced power system flexibility:

- Revising market mechanisms and regulations to enhance long-term flexibility.
- Increase demand responsiveness to activate demand's potential for more efficient system interaction.
- Smoothing wind power variations, for instance by coordinated operation of storage units.
- Using storage unit's for balancing purposes.
- Using cross-border interconnections to benefit flexibility sources of neighboring grids.

The added flexibility level should be provided in economic ways, otherwise power system operation costs will be significantly elevated. In this thesis we focus on the economic aspects of integrating wind power into power system. The topics in this dissertation cover the general scope of optimal



operation of power systems with significant wind power penetration from a techno-economic perspective.

## 8.1 Conclusions

In chapter 1 the research topic and project milestones are introduced. Chapter 2 introduces Danish power system considering its high penetration of wind power. The historical development of electricity market is reviewed by conducting a data survey. The main contributions of the PhD thesis are given in chapters 3 to 7 as below.

*Chapter 3:* Excessive price reduction and extreme volatility are introduced as two emerging problems in electricity markets with significant wind penetration. A comparative study has been conducted under uniform and pay-as-bid pricing mechanisms to investigate the bidding behavior of generation companies under different pricing schemes.

*Chapter 4:* Optimal cooperative operation of a wind-storage facility for mitigating wind imbalance and participation in regulation service is studied. Battery units are considered to be operating coordinated with a wind farm. Two different functions of storage units are investigated. Primarily it is assumed that the SU's sole responsibility is to mitigate wind power imbalances. The second function gives the possibility to SU to participate in balancing market in addition to mitigating wind power imbalances. The optimal interaction of storage units are compared in both scenarios.

*Chapter 5:* The price difference between peak and off-peak hours is not incentivizing enough to encourage consumers to shift their loads from peak to off-peak periods. A price based approach is proposed by which Demand Response Aggregator (DRA) can increase demand responsiveness and shift the load from peak to off-peak hours. This is done by increasing the difference between peak and off-peak hours. The result is a new sets of electricity price by which demand is more efficiently shifted to off-peak periods. This will reduce power system stress conditions and enhance power system reliability. Then the impact of proposed idea is investigated for peak reduction in a distribution feeder with high EV penetration. To this end, an optimal EV scheduling procedure is presented and the impact of new price sets on feeder loading is investigated. The results show that

proposed price incentives can shift electric vehicle charging to mid-night periods when the power system is lightly loaded.

*Chapter 6:* Different types of reserves namely upward/downward primary, secondary, and tertiary services are decoupled by a mathematical framework. This provides the share of conventional power plants for reserve provision within the control area itself and also from cross border interconnections. Results explain the behavior of reserve procurement cost under different scenarios. The role of interconnections for reserve provision is investigated. Western Danish power system is studied.

*Chapter 7:* In this chapter a model is proposed for successive energy and reserve scheduling in an electricity market with exogenous reserve regulations (where primary, secondary and tertiary reserve values are pre-defined). The environmental impact of different reserve providing technologies is taken into account in the model. Wind power and EV are also considered as reserve providers in the proposed model. Results show how the environmental impact of reserve providers modifies the share of different generation technologies in upward and downward reserves.

## **8.2 Future work**

Some other interesting and relevant topics are identified during the process of research work. These topics that can be considered for future research are as follows:

- 1) A power system with high wind power penetration needs significant sources for ancillary services to meet the variability of wind power. Technical possibility of providing ancillary services from wind farms is an interesting topic to be addressed. Different wind turbine technologies can be investigated for providing ancillary services from wind technology.
- 2) Development of sophisticated models for demand's price sensitivity is an important research topic. Many studies in power system literature make simplifications about demand responsiveness which make the results of the studies too optimistic. Also the effects of tax issues on the costumers' energy cost need to be researched.

- 3) Statistical correlation among electricity price, demand and wind power production in Nordic intra-day balancing market (Elbas) needs to be investigated. Revised market structure and mechanism needs to be developed to activate the balancing potential of this market.
- 4) The battery unit can be modelled in more detail. For instance depreciation can be taken into account to increase the life time of the battery.
- 5) The proposed operational and control strategies should be further validated in larger sized power systems. The tools for implementing the proposed techniques such as communication infrastructures should be also modelled. A Real Time Digital Simulator (RTDS) should be used to verify the functionality of proposed algorithms.
- 6) Electric Vehicle will consist a considerable percentage of electric load in the coming decade. EVs have high potentials to provide balancing services in power systems with high wind power penetration. This is mainly due to higher wind power production in night time when EVs are more likely to be available for charging. Coordinated operation of EVs for balancing services is an important research question which will be addressed in future research works.

## References

[1] ECOFYS, Fraunhofer ISI, Energy Economic Group, "Renewable Energy Policy Country Profile", Based on policy information available in November 2011, Prepared within the Intelligent Energy Europe project: [www.reshaping-res-policy.eu](http://www.reshaping-res-policy.eu)

## List of publications

- [1] Mostafa F. Astaneh; Zhe Chen; Mousavi, O.A., "Excessive price reduction and extreme volatility in wind dominant electricity markets; solutions and emerging challenges," *Power and Energy Society General Meeting (PES), IEEE* , 21-25 July 2013.
- [2] Mostafa F. Astaneh; Rather, Z.H.; Weihao Hu; Zhe Chen, "Economic valuation of reserves on cross border interconnections; A Danish case study," *Power and Energy Society General Meeting (PES), IEEE* , 27-31 July 2014.
- [3] Mostafa F. Astaneh; Hu, Weihao; Chen, Zhe, "Cooperative optimal operation of wind-storage facilities," *Power and Energy Engineering Conference (APPEEC), 2014 IEEE PES Asia-Pacific*, 7-10 Dec. 2014.
- [4] Mostafa F. Astaneh, Bishnu P. Bhattarai, Birgitte Bak-Jensen, Weihao Hu, Jayakrishnan R. Pillai, Zhe Chen, "A Novel Technique to Enhance Demand Response: an EV-based Test Case", Accepted in *IEEE PES IREC (6<sup>th</sup> International Renewable Energy Conference)*, 2015, Tunisia.
- [5] Mostafa F. Astaneh, Weihao Hu, Zhe Chen, "A Comparative Study between Two Market Clearing Schemes in Wind Dominant Electricity Markets", *IET Generation, Transmission & Distribution*.
- [6] Mostafa F. Astaneh, Weihao Hu, Zhe Chen, "Coordinated Operation of Wind-Storage Facilities Considering Power System Balancing Conditions", *IET Generation Transmission & Distribution*, Special Issue of Optimal Utilization of Storage Systems in Transmission and Distribution Systems (status: under review).
- [7] Mostafa F. Astaneh, Zakir Hussain Rather, Weihao Hu, Zhe Chen "Reserve Scheduling Considering Environmental Impact of Reserve Service Providers", *Elsevier International Journal of Electrical Power and Energy Systems* (status: under review).
- [8] Mostafa F. Astaneh, Weihao Hu, Zhe Chen, "Risk-Based Quantifying of Reserve Requirement in Wind Dominant Power Systems", *Elsevier International Journal of Electrical Power and Energy Systems* (status: under review).
- [9] Mostafa F. Astaneh; Zhe Chen, "Price volatility in wind dominant electricity markets," *IEEE EUROCON*, 1-4 July 2013.