



AALBORG UNIVERSITY
DENMARK

Aalborg Universitet

Isolation between three antennas at 700 MHz

Bahramzy, Pevand; Svendsen, Simon; Pedersen, Gert F.

Published in:
IET Microwaves, Antennas & Propagation

DOI (link to publication from Publisher):
[10.1049/iet-map.2014.0313](https://doi.org/10.1049/iet-map.2014.0313)

Publication date:
2015

Document Version
Publisher's PDF, also known as Version of record

[Link to publication from Aalborg University](#)

Citation for published version (APA):
Bahramzy, P., Svendsen, S., & Pedersen, G. F. (2015). Isolation between three antennas at 700 MHz: for handheld terminals. IET Microwaves, Antennas & Propagation, 9(3), 237-242. DOI: 10.1049/iet-map.2014.0313

General rights

Copyright and moral rights for the publications made accessible in the public portal are retained by the authors and/or other copyright owners and it is a condition of accessing publications that users recognise and abide by the legal requirements associated with these rights.

- ? Users may download and print one copy of any publication from the public portal for the purpose of private study or research.
- ? You may not further distribute the material or use it for any profit-making activity or commercial gain
- ? You may freely distribute the URL identifying the publication in the public portal ?

Take down policy

If you believe that this document breaches copyright please contact us at vbn@aub.aau.dk providing details, and we will remove access to the work immediately and investigate your claim.

Published in IET Microwaves, Antennas & Propagation
 Received on 13th May 2014
 Revised on 6th August 2014
 Accepted on 2nd September 2014
 doi: 10.1049/iet-map.2014.0313

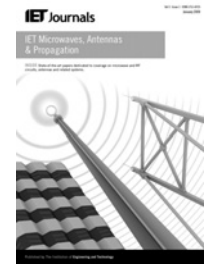

ISSN 1751-8725

Isolation between three antennas at 700 MHz: for handheld terminals

Pevand Bahramzy^{1,2}, Simon Svendsen¹, Gert F. Pedersen²

¹Intel Mobile Communication Denmark Aps, Norresundby, Denmark

²Section of Antennas, Propagation and Radio Networking (APNet), Aalborg University, Aalborg DK-9220, Denmark

E-mail: pevand.bahramzy@intel.com

Abstract: To address the antenna design challenges posed by many frequency bands, introduced with long-term evolution deployment, this study proposes the use of separate transmit (Tx) and receive (Rx) narrow-band antennas. In addition, a diversity Rx (Dx) antenna is needed for multiple-input multiple-output performance. Although the isolation between two antennas at low frequencies (700 MHz) is crucial for the successful implementation of 4G in handheld terminals, it becomes more challenging when considering isolation among three antennas (one Tx and two Rx antennas) at low frequencies. Hence, a method that improves the isolation between the ports of one Tx and two Rx antennas is presented here.

1 Introduction

Long-term evolution (LTE) is deployed in order to meet the increased desire for high data rate in mobile terminals. In this context, the frequency spectrum is widened, ranging from 700 to 3800 MHz [1]. This poses enormous challenges to the design of antennas in small form factors due to the fundamental limitation of antennas [2]. Furthermore, the transceiver radio frequency (RF) front-end (FE) architecture is complicated a lot because of the increased number of bands and band combinations. In a traditional FE, the transmitter (Tx) and receiver (Rx) are separated by employing a duplex filter, which provides the required isolation.

Co-design of the RF FE and the antenna system is a promising approach that can help miniaturising the RF FE and antenna, while covering the increased number of bands. In such a case, separate Tx and Rx chain throughout the FE (including antennas) can be applied. This FE concept requires separate Tx and Rx narrow-band antennas exhibiting a higher isolation [3]. These antennas only need to cover the LTE channel bandwidth (BW), ranging from 1.4 to 20 MHz. However, the 20 MHz BW is only used for extremely high data throughput applications. Hence, 10 MHz is assumed as the maximum BW. The requisite frequency range can be covered by applying tuning components. Owing to the lack of duplex filter, an isolation of some 25 dB should be provided by the narrow-band antennas [4].

The low cellular bands, in particular, suffer from low efficiency and high coupling between the antennas. High antenna coupling often leads to high correlation in the branches of the multiple-input multiple-output (MIMO) receiver. Owing to the frequency offset and narrow-band characteristic, good isolation is achievable between the Tx

and Rx antennas at 700 MHz [5]. However, a diversity Rx (Dx) antenna is needed for MIMO performance. At 700 MHz, it becomes quite a challenge to obtain good isolation from Tx to Rx and Dx simultaneously, while having a decent isolation between the two Rx antennas. To address this, the paper proposes the use of a balanced antenna structure as Dx antenna.

Balanced antennas have been investigated previously [6, 7], where good isolation has been achieved towards the unbalanced antenna placed next to the same printed circuit board (PCB). In this paper, balanced antenna is utilised in the proposed FE architecture, where very high isolation is needed between the three antennas. For simplicity and proof of concept, a conventional dipole is used as the balanced antenna, and the Tx and Rx antennas are conventional monopole-type antennas.

The paper is organised as follows: Section 2 addresses the isolation challenges between three monopole-type antennas as well as describing the search methodology for optimal antenna placement. Performance of the balanced antenna next to a PCB is studied in Section 3. Section 4 shows how high isolation can be achieved using a balanced antenna and a monopole antenna. Following this, in Section 5, the advantage of balanced antenna, when placed next to the same PCB as the two monopole antennas, is presented. The conclusion is drawn in Section 6.

2 Three monopoles on PCB

Three antenna elements are needed (Tx, Rx and Dx) in the proposed FE architecture. High isolation (≥ 25 dB) is required from Tx to Rx and Dx antennas simultaneously. In addition, decent isolation (10 dB or better) is needed between the two Rx antennas for high decorrelation. As

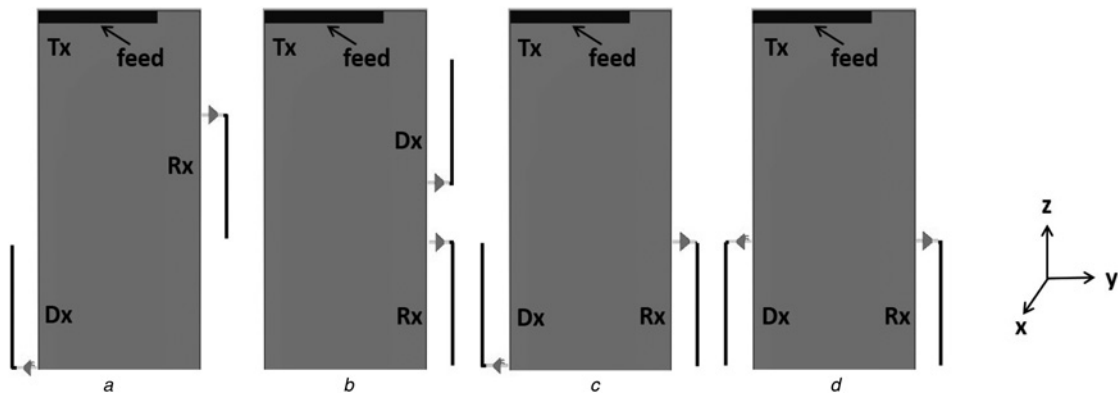

Fig. 1 Different position scenarios of three monopoles on the PCB

illustrated in Fig. 1, four antenna position configurations have been analysed in search of optimal isolation. All configurations have Tx at the top and Rx, Dx at different positions on the side of PCB with opposite and same feeding. The classical top and bottom case is not considered, as it leads to poor isolation due to the excitation of same PCB mode.

The antenna elements, used for the analysis, are simple monopole-type antennas. The Tx monopole has the dimensions $40 \times 2 \times 1 \text{ mm}^3$ and the two Rx monopoles have similar size ($40 \times 3 \times 2 \text{ mm}^3$). The antennas are designed to service LTE band 12, where Tx element covers just the Tx part and Rx antennas cover the Rx part, with 30 MHz duplex-spacing in between. The size of PCB is considered to be of smartphone size, more precisely $120 \times 55 \text{ mm}^2$. The simulations have been carried out using a commercial finite-difference time-domain electromagnetic solver. The

conductor is modelled as perfect electrical conductor and there is no substrate included in the simulations. Commercial inductors are used as matching components, configured as series and shunt inductors.

Worst-case isolation results are listed in Table 1, showing that in all four cases around -20 dB isolation can be obtained between Tx and Rx antennas. However, the isolation between Tx and Dx antennas is as good only in case (d) at the expense of very poor isolation (-3 dB) between Rx and Dx antennas. Configuration (a) seems to be the most optimal and is therefore chosen for further investigations.

The S-parameters of configuration (a), covering LTE band 12, are shown in Fig. 2. In the figure, it can be seen that the required isolation (25 dB) between the Tx and the two Rx

Table 1 Worst-case isolation results in LTE band 12

Configuration	Coupling (Tx, Rx), dB	Coupling (Tx, Dx), dB	Coupling (Rx, Dx), dB
a	-21	-14	-6
b	-19	-13	-4
c	-20	-13	-5
d	-23	-21	-3

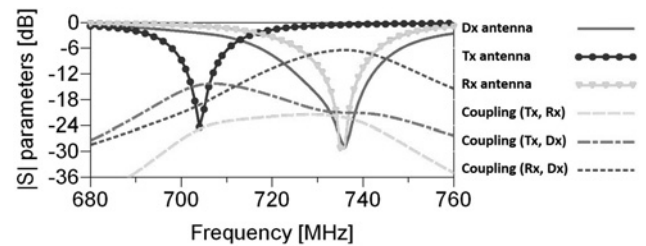

Fig. 2 Simulated S-parameters of the three monopoles

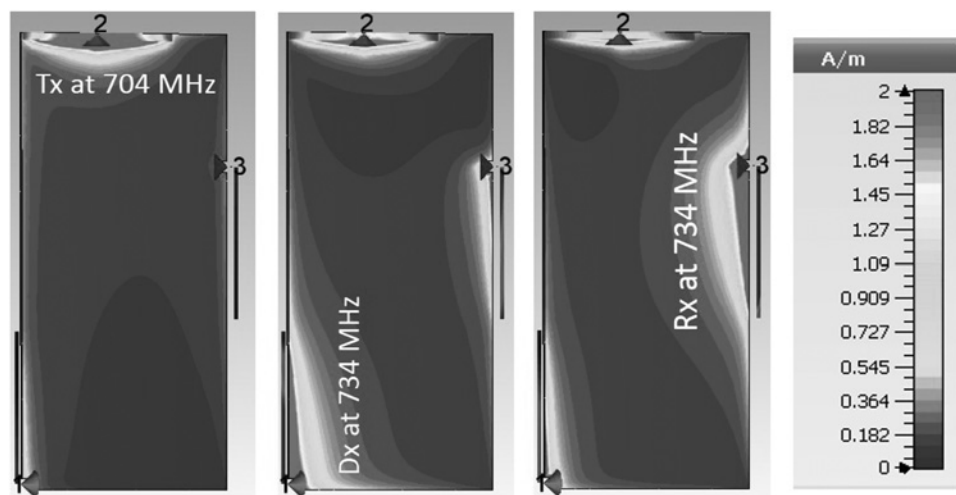

Fig. 3 Current distribution: Tx antenna at 704 MHz, Dx and Rx antenna at 734 MHz

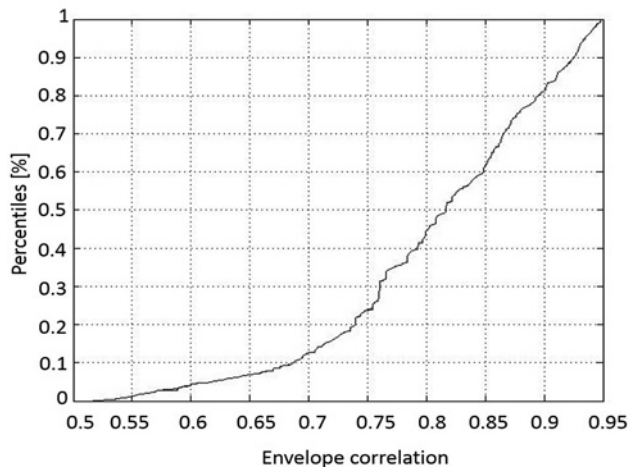

Fig. 4 Correlation between Rx and Dx antennas at 734 MHz

antennas is not achieved. The coupling between the two Rx antennas is also high (6 dB), leading to poor correlation. In spite of both Rx antennas having the same size and matched in the same way, it is seen that the Dx antenna exhibits a wider BW, which is due to strong coupling. There are basically two modes at these frequencies: one along the length of PCB, and one along the width. Therefore, good isolation to the Rx can be achieved. However, placing the Dx antenna anywhere on PCB would either couple to the Tx or the Rx or both. Therefore, it is very challenging (even impossible) to obtain 25 dB or better isolation towards Rx and Dx antennas and at the same time have decent isolation between the Rx and Dx antennas.

The current distribution plots, shown in Fig. 3, illustrate how coupled the three antennas are. With the Tx antenna operating at 704 MHz, small amount of currents can be observed at the Dx antenna and almost no current at the Rx antenna location. This agrees with the results in Fig. 2, where the Tx antenna couples a little more to the Dx antenna compared to the Rx antenna. Looking at Dx antenna operating at 734 MHz, it is seen that it couples to Tx and Rx antennas. The same is the case for the Rx antenna also operating at 734 MHz.

In MIMO mode, multiple antennas that work simultaneously must be decoupled and decorrelated in order to benefit from a maximum power transfer and from multipath. This can be ensured when the antennas are separated with a distance equal or greater than $\lambda/2$, where λ is the wavelength. At 700 MHz, λ is 43 cm and hence this separation is not feasible in handheld terminals. A commonly used number of antenna envelope correlation, for achieving some diversity gain, is $\rho_e \leq 0.5$ [8, 9]. All correlation results, presented in this paper, are of the envelope correlation [10], since it is the most commonly used. Correlation between the Rx antennas is calculated using an isotropic channel model (power is the same from all incoming directions) and a directive channel model [11] (power is mainly coming from one direction). The correlation, using an isotropic channel model, is typically lower. In the case of directive channel model, the PCB + antennas are rotated in all three dimensions (x, y, z), with a rotation angle step size of 30° , in order to obtain correlation not only at single point in space, but at all possible angles.

The correlation using an isotropic channel model is 0.83, which is way higher than 0.5. The correlation using directive channel model is shown in Fig. 4, where it is seen that 95% of the time, the correlation is 0.93 or lower. The

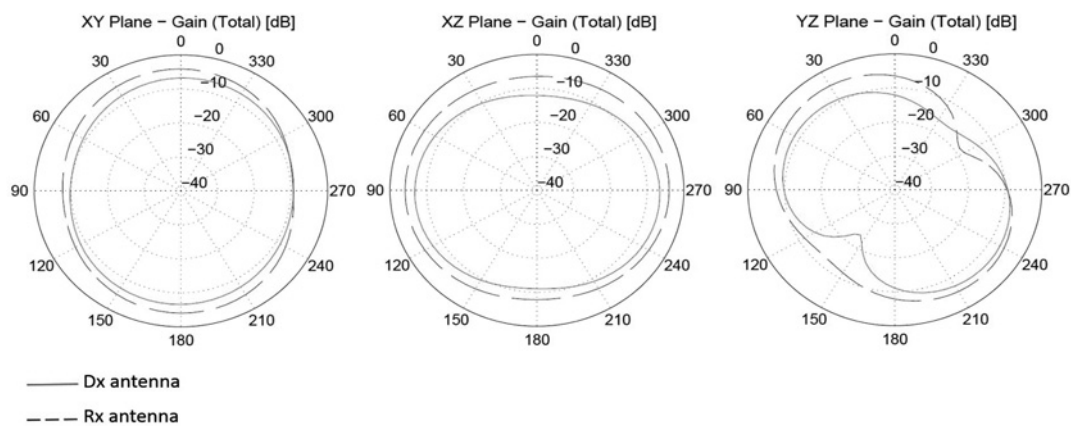

Fig. 5 Radiation pattern of Rx antenna (long dash line) and Dx antenna (solid line) at 734 MHz

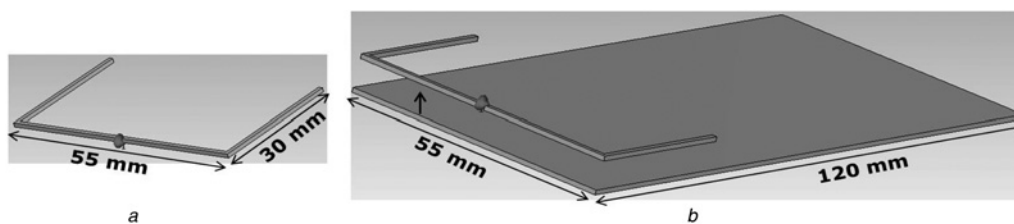

Fig. 6 Dipole in FS and at different distances from the PCB

a Dipole in FS

b Dipole on PCB with varying distances

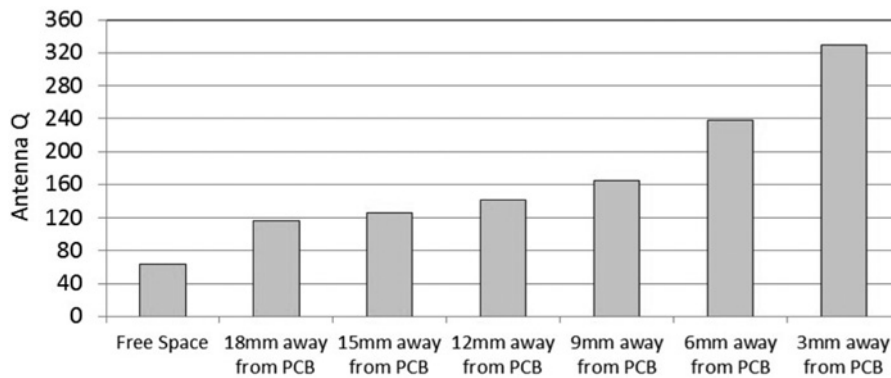

Fig. 7 Unloaded dipole Q , in FS and at different distances from the PCB, at 700 MHz

Rx and Dx antennas are highly correlated and therefore do not benefit much in the throughput. The two antennas are basically acting as one antenna, which is also seen looking at the radiation patterns of the two antennas in Fig. 5.

3 Balanced antenna on PCB

Before utilising the balanced antenna as Dx antenna, it is important to study its performance next to the PCB. Hence, the dipole Q , next to the PCB, is evaluated at 700 MHz. Moreover, the optimal distance from the PCB, giving 10 MHz BW and acceptable antenna efficiency, is investigated.

Fig. 6 shows the dipole in free space (FS) and next to the PCB. For all cases, the dipole is matched at 700 MHz using an ideal series and shunt inductors. The simulations are lossless in order to see the unloaded antenna Q .

As seen in Fig. 7, the lowest Q is obtained for the FS case with $Q=60$, which is still very high if compared to the required Q of 3.25 at low band. As dipole distance to the PCB decreases, its Q increases almost exponentially. Considering the smartphones nowadays, an antenna distance of more than 6 mm from the PCB is not realistic, and antenna Q is 238 at such a distance. The Q values shown in the figure are worst-case values and they will be lower when loss is introduced.

A 10 MHz BW at 700 MHz equals an antenna Q of 80, which is three times lower than the Q of the dipole at 6 mm distance from the PCB. Hence, a series resistor is added to emulate loss and its value is increased until a matched BW

Table 2 Q and loss of the dipole, 3 mm and 6 mm away from the PCB, at 700 MHz

	Unloaded Q	Resistance, Ω	Loaded Q	Loss, dB
6 mm	238	3	80	4.5
3 mm	330	3	80	6.1

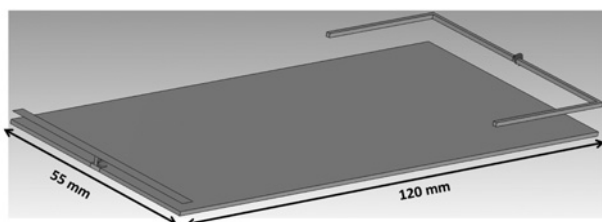

Fig. 8 Dipole and monopole antenna on PCB

of 10 MHz at a standing wave ratio of 3 is obtained. As illustrated in Table 2, for dipole 6 mm away, a loss of 4.5 dB is needed to obtain BW of 10 MHz. The loss increases to 6.1 dB when decreasing the distance to 3 mm. However, this loss is implemented as a series resistor at the excitation port, which has a more positive influence on the BW than the typical dielectric and conductive losses common for antennas. The loss is therefore expected to be higher in reality. The 6 mm distance from the PCB seems to be practicable and also causes acceptable antenna loss. Hence, this distance is used in the following sections.

4 Balanced and monopole antenna on PCB

The balanced antenna (dipole) is located 6 mm away from the top part of the PCB and the monopole is placed at the bottom with the dimensions $55 \times 3 \times 2 \text{ mm}^3$, see Fig. 8. Both antennas are matched using a series and a shunt inductor.

As depicted in Fig. 9, both antennas are of 10 MHz BW, while they exhibit isolation of 65 dB towards each other.

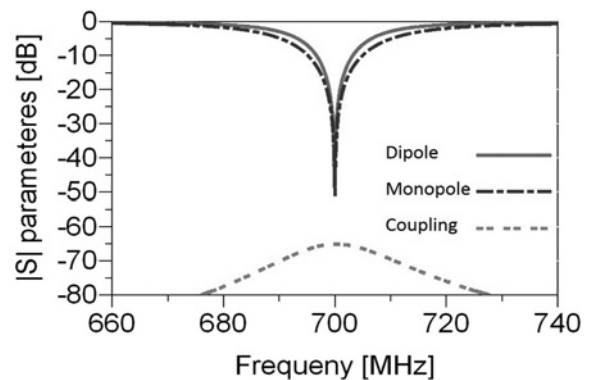

Fig. 9 S -parameters of the dipole and monopole

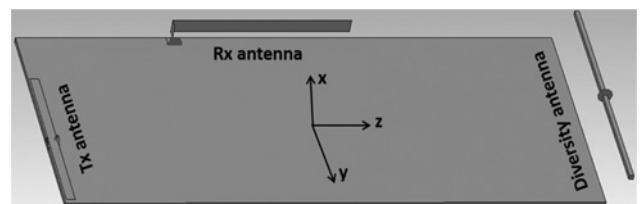

Fig. 10 Tx monopole, Rx monopole and Dx dipole placed on PCB for optimal isolation

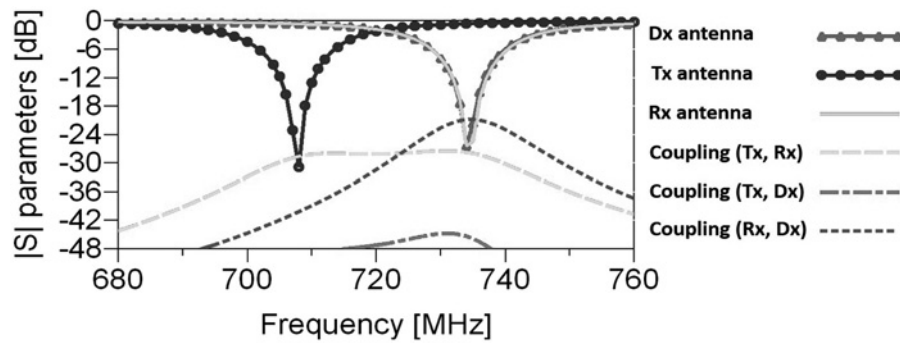

Fig. 11 Simulated S -parameters of Tx monopole, Rx monopole and Dx dipole



Fig. 12 Current distribution: Tx antenna at 704 MHz, Dx and Rx antennas at 734 MHz

The reason for the excellent isolation is that the balanced antenna is self-radiating and do not use PCB for radiation, where the monopole antenna is just a coupler that excites the PCB which is the main radiator. Hence, they can be much more decoupled compared to two monopoles exciting the same PCB.

5 Balanced antenna and two monopoles on PCB

The above case is now extended to three antennas: Tx monopole, Rx monopole and a Dx antenna as a balanced-type antenna. As depicted in Fig. 10, by positioning these antennas optimally on the PCB, good isolation can be obtained in between them. The Tx monopole ($40 \times 2 \times 1 \text{ mm}^3$) and Rx monopole ($40 \times 3 \times 2 \text{ mm}^3$) have the same sizes as in Section 2, and the Dx dipole has the dimensions $55 \times 1 \times 6 \text{ mm}^3$. A series and a shunt inductor is used to match each of these three antennas.

In Fig. 11, it is seen that each antenna has a BW of 10 MHz. The Tx monopole is matched at Tx half of LTE band 12, while the Rx monopole and Dx dipole are matched at Rx half of the band. From the figure it is seen that an isolation of -45 dB or better is obtained between the Tx monopole and the Dx dipole, and an isolation of -28 dB or better is obtained between Tx and Rx monopole. The isolation between the two Rx antennas is also excellent (-21 dB), allowing decent correlation.

Looking at the current distribution plots, shown in Fig. 12, it is evident that each antenna couples very little to the ports of the other two antennas.

The correlation using an isotropic channel model is 0.23, which is well within the limit of 0.5. The correlation using directive channel model is shown in Fig. 13, where it is seen that 95% of the time the correlation is 0.49 or lower. The two Rx antennas are now sufficiently decorrelated, which is also seen from the radiation patterns (see Fig. 14).

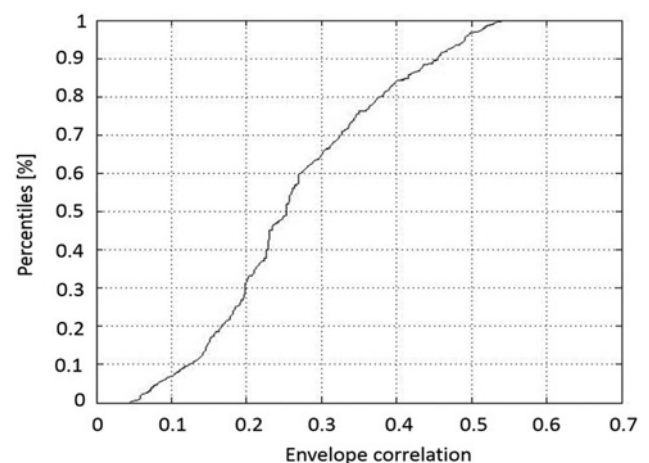

Fig. 13 Correlation between the two Rx antennas at 734 MHz

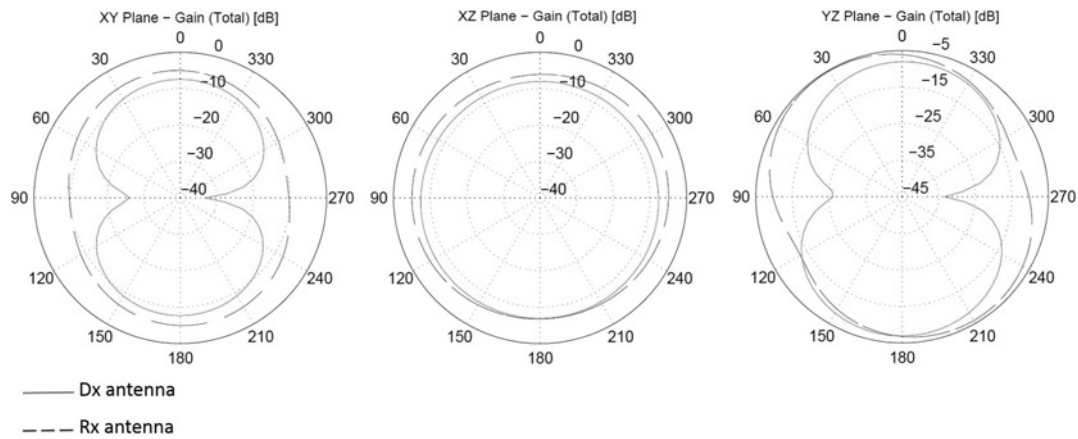

Fig. 14 Radiation pattern of Rx antenna (long dash line) and Dx antenna (solid line) at 734 MHz

6 Conclusion

This paper presents a method for obtaining high isolation between Tx, Rx and Dx antennas at low frequencies. It is shown that, by substituting one of the conventional monopole-type antennas with a balanced antenna structure, high isolation can be obtained between all three antennas. In this way, low correlation can also be achieved in the branches of the MIMO receiver. However, this good isolation does not come for free. The dipole antenna requires a balanced feeding and causes high loss due to its high-Q nature.

7 Acknowledgments

This work is supported by the Smart Antenna Front End (SAFE) project within the Danish National Advanced Technology Foundation – High Technology Platform.

8 References

- 1 Evolved Universal Terrestrial Radio Access (E-UTRA); User Equipment (UE) radio transmission and reception, 3GPP Std. TS 36.101, <http://www.3gpp.org/ftp/Specs/html-info/36101.htm>
- 2 Chu, L.J.: 'Physical limitations of omni-directional antennas', *J. Appl. Phys.*, 1948, **19**, (12), pp. 1163–1175
- 3 Pelosi, M., Knudsen, M.B., Pedersen, G.F.: 'Multiple antenna systems with inherently decoupled radiators', *IEEE Trans. Antennas Propag.*, 2012, **60**, (2)
- 4 Barrio, S.C.D., Tatomiurescu, A., Pedersen, G.F., Morris, A.: 'Novel architecture for LTE world-phones', *IEEE Antennas Wirel. Propag. Lett.*, 2013, **12**
- 5 Bahramzy, P., Pedersen, G.F.: 'Isolation of high-Q antennas for mobile handsets'. Antennas and Propagation Society Int. Symp. (APSURSI), 2013
- 6 Li, H., Lau, B.K., Ying, Z., He, S.: 'Decoupling of multiple antennas in terminals with chassis excitation using polarization diversity, angle diversity and current control', *IEEE Trans. Antennas Propag.*, 2012, **60**, (12)
- 7 Ilvonen, J., Kiveks, O., Azremi, A.A.H., Valkonen, R., Holopainen, J., Vainikainen, P.: 'Isolation improvement method for mobile terminal antennas at lower UHF band'. Proc. Fifth European Conf. Antennas and Propagation (EUCAP)
- 8 Vaughan, R., Andersen, J.B.: 'Channels, propagation and antennas for mobile communications', *IEE Electromagn. Waves Ser.*, 2003, **50**
- 9 Lau, B.K., Andersen, J., Kristensson, G., Molisch, A.: 'Impact of matching network on bandwidth of compact antenna arrays', *IEEE Trans. Antennas Propag.*, 2006, **54**, (11), pp. 3225–3238
- 10 Pierce, J., Stein, S.: 'Multiple diversity with nonindependent fading', *Proc. IRE*, 1960, **48**, (1), pp. 89–104
- 11 Knudsen, M., Pedersen, G.F.: 'Spherical outdoor to indoor power spectrum model at the mobile terminal', *IEEE J. Sel. Areas Commun.*, 2002, **20**, (6), pp. 1156–1169