



Aalborg Universitet

AALBORG UNIVERSITY
DENMARK

Reactive Power Support of Electrical Vehicle Charging Station Upgraded with Flywheel Energy Storage System

Sun, Bo; Dragicevic, Tomislav; Savaghebi, Mehdi; Quintero, Juan Carlos Vasquez; Guerrero, Josep M.

Published in:
PowerTech, 2015 IEEE Eindhoven

DOI (link to publication from Publisher):
[10.1109/PTC.2015.7232719](https://doi.org/10.1109/PTC.2015.7232719)

Publication date:
2015

Document Version
Early version, also known as pre-print

[Link to publication from Aalborg University](#)

Citation for published version (APA):

SUN, B. O., Dragicevic, T., Savaghebi, M., Vasquez, J. C., & Guerrero, J. M. (2015). Reactive Power Support of Electrical Vehicle Charging Station Upgraded with Flywheel Energy Storage System. In PowerTech, 2015 IEEE Eindhoven (pp. 1-6). IEEE Press. DOI: 10.1109/PTC.2015.7232719

General rights

Copyright and moral rights for the publications made accessible in the public portal are retained by the authors and/or other copyright owners and it is a condition of accessing publications that users recognise and abide by the legal requirements associated with these rights.

- ? Users may download and print one copy of any publication from the public portal for the purpose of private study or research.
- ? You may not further distribute the material or use it for any profit-making activity or commercial gain
- ? You may freely distribute the URL identifying the publication in the public portal ?

Take down policy

If you believe that this document breaches copyright please contact us at vbn@aub.aau.dk providing details, and we will remove access to the work immediately and investigate your claim.

Reactive Power Support of Electrical Vehicle Charging Station Upgraded with Flywheel Energy Storage System

Bo Sun, Tomislav Dragicevic, Mehdi Savaghebi, Juan C. Vasquez, and Josep M. Guerrero

Department of Energy Technology – Microgrids Research Programme www.microgrids.et.aau.dk
Aalborg University, Denmark
{sbo, tdr, mes, juq, joz}@et.aau.dk

Abstract—Electrical vehicles (EVs) are presenting increasingly potential to replace the conventional fossil fuel based vehicles due to environmental friendly characteristic. Accordingly, Charging Stations (CS), as an intermediate between grid and large numbers of EVs, are supposed to have more critical influence on future smart transportation network. This paper explores an off-board charging station upgraded with flywheel energy storage system that could provide a reactive power support to the grid utility. A supervisory control scheme based on distributed bus signaling is proposed to coordinate the operation of each component in the system. As a result, the charging station could supply the reactive power support to the utility grid without compromising the charging algorithm and preserve the battery's lifetime. Finally, the real-time simulation results based on dSPACE1006 verifies the proposed strategy.

Index Terms—EV charging station, Flywheel energy storage system, distributed bus signaling

I. INTRODUCTION

Due to awareness of growing serious environmental issues and energy crisis, it has become a consensus to reduce fossil fuel usage and air-pollution emission. During last decades, the transportation is responsible for around 25% of total carbon dioxide emissions, and conventional fossil fuel based vehicles accounts for 74% of total transportation pollutions [1]. In turn, the concept of more electrical vehicle (MEV) is involved in smart grid frameworks of many developed countries for cleaner high-quality energy and sustainable development [2].

MEV can be connected to the grid including both plug-in hybrid vehicle (PHEV) and Plug-in electric vehicle (PEV). The propulsion of PEV is totally resolved by an electric engine, while PHEV is driven by a combination of the electric and internal combustion engine (ICE) [3]. At present, PHEV is a more cost-effective choice for most consumers due to the current price of fossil fuel and Li-Ion battery, while PEV is more efficient and environmental friendly [4]. Since EVs are expected to play a significant role in future smart grid, it is critical to provide safe and appropriate interfaces for integrating PEV fleets to the grid.

Up to now, industry has defined three power levels for EV charging. Level 1 charging commonly takes place at home during night with power around 2kW and requires more than 10 hours; level 2 charging can be carried out in both private or public sites with power less than 20kW; level 3 charging, which is defined as typical fast DC charging, is proposed for commercial and public applications, such as fast charging stations (FCSs) as gas stations today.

The chargers for electrical vehicles (EV) battery can be categorized into on-board and off-board charger with unidirectional and bidirectional power flow [5]. At present, most EVs are using a single-phase on-board charger, which is suitable for low power level 1 and 2 charging, but with limitation of size, weight and cost constraints. Off-board fast charging stations dedicated to EV fleets are one promising option for widespread market penetration of EVs in future. At these charging stations, AC grid voltage is converted into a DC bus for charging the EV through a DC/DC converter. Unidirectional or bidirectional converters can be used in off-board charging stations as grid power electronics interface, including diode-bridge, three-phase active buck/boost, Matrix rectifiers, and Vienna rectifiers [6]-[7]. Similar to unidirectional converters, the bidirectional ones can be used to supply ancillary services such as reactive power compensation, voltage and frequency regulation and so on to the main power grid, [4].

The concept V2G has been discussed for several years which means sending active power from vehicles to the grid [8]. The implementation method, effect and economic benefits of this operation have been a focus in recent decade [9], [10]. The batteries of EV can be regarded as bulk energy storage when connected to the grid in charging mode, however this operation have to interfere the recommended charging pattern by battery manufacturer, which may accelerate the degrading of battery, thus, reducing its lifetime. Compared with active power services, reactive power ancillary services may be more

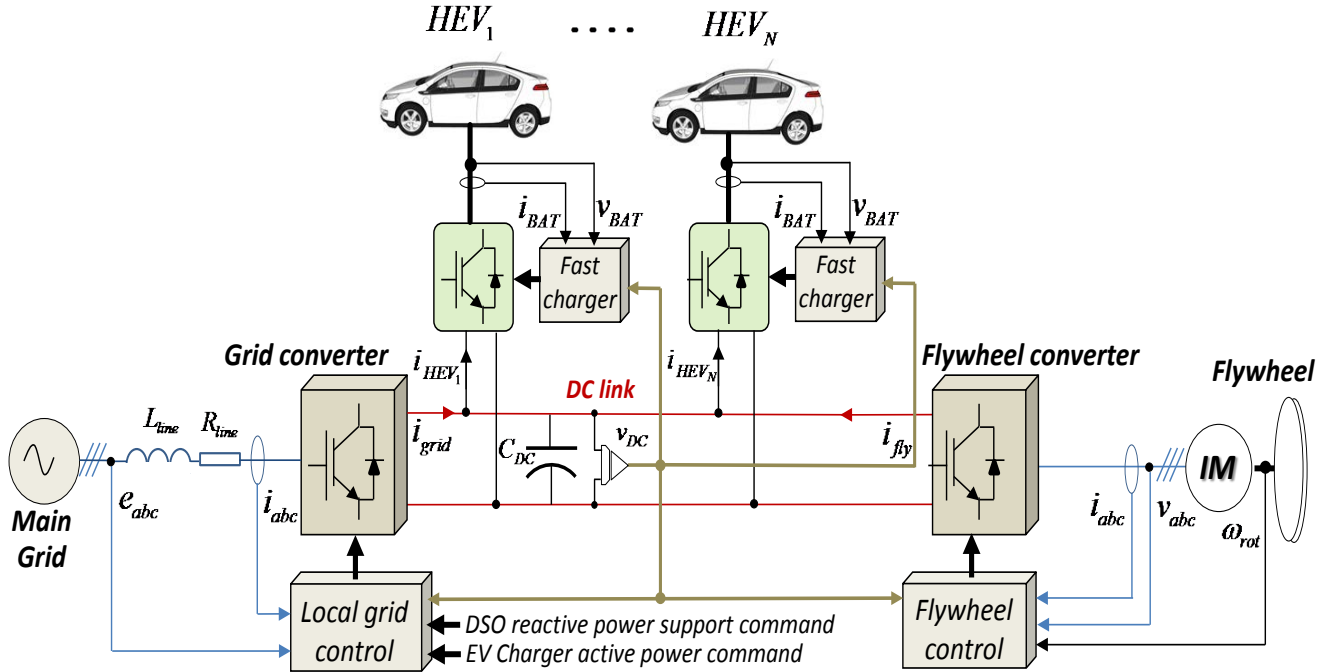

Figure 1. Configuration of the Charging station upgraded with a FESS

promising to be implemented in real applications. Recent studies have shown that the battery is not affected due to reactive power operation [11]. Reference [12] have discussed the design, control and assessment of onboard charger reactive power support, however the reactive power support by onboard charger is limited by the mobility and power rating. In [13], the authors managed to supply the reactive power compensation service in a fast charging station and proposed a control strategy for the off-board charger. In this approach, due to the apparent power limitation of grid converter, the active power supplied to EV has to be reduced as a trade-off when reactive power service is implemented, hence the regular charging process of EV is affected more or less, which may lead to a decreased battery life-time.

As another approach, [14] proposes to employ an independent energy storage system (ESS) to the common DC bus. This way, the ESS could create a power buffer to share some active power with the EV. Regarding the ESS, battery is most commonly used, but the degradation is a serious problem of BESS for long periods in aggressive environments (high current peaks, frequent cycling). Compared with BESS, flywheel is a mature and cheap technology with high power density which supports for large number of charge/discharge cycles.

In this paper, a low-speed flywheel is used in an off-board charging station for sharing part of active power when reactive power support is supplied to the grid utility. A supervisory control scheme is proposed for coordination of each part of the system. In particular, a distributed bus signaling (DBS) strategy [15] has been applied so that the communication between grid and flywheel converters is not needed. Based on

the proposed scheme, the charging station could supply the reactive power to the utility grid without compromising the charging algorithm and battery life time.

II. DISCUPTION OF THE OFF-BOARD EV CHARGING STATION

A basic structure of a charging station upgraded with flywheel ESS (FESS) is depicted in Fig. 1. It comprises a DC/DC converter as charger and two three phase bidirectional full bridge converters (one is connected to the grid utility through inductor filter and the other is used as flywheel converter).

As is presented, grid converter is in charge of generating a common dc link by connecting the EV battery and flywheel through DC/DC and DC/AC converters, respectively. In order to avoid over modulation of inverters and provide enough high input voltage for buck type DC/DC converter, a 650V common DC bus is used in this study. Additionally a flywheel energy storage system driven by an induction machine is applied. The system electrical parameters can be found in Table I.

When the EV users enter the charging station, they can choose the charging power level (slow, fast, or mixed) and charging patterns (“park & charge” or “charge & go”) [16]. If they choose “park & charge”, it is possible for FCS owner to utilize the facilities to provide some reactive power services for the grid to obtain lower electric prices according to the agreement with utility.

Obviously in this operation of FCS, it is crucial to coordinate the power flowing from different converters. Each component in the system is linked based on a DC bus, the

TABLE I. ELECTRICAL PARAMETERS

Electrical parameters	
DC bus capacitor C_{DC}	2.2mF
Line inductor L_{line}	3.8mH
Line resistor R_{line}	0.2Ω
DC bus voltage V_{dc}	650V
Grid voltage $V_{grid}(p-p)$	325V
Flywheel parameters	
Stator inductor L_s	10.46 mH
Rotor inductor L_r	10.76 mH
Total leakage coefficient σ	0.0556
Inertia J	10 kgm ²
Stator resistance R_s	1.945 Ω
Rotor resistance R_r	2.3736 Ω

controller of the system should satisfy the principles as follows:

- Meeting the required active power level requested by the EV customer
- Providing a timely response to the reactive power request from the distribution system operator (DSO);
- Compensating the probable active power shortage for EV by FESS and recharging it automatically to nominal speed after EV charging;

- Not exceeding the power rating limitation of the converters;
- Ensuring plug and play features for seamless installation of additional HEV chargers and ESS.

Furthermore, it should be noted that the guarantee of charging service of EV user is always the priority.

III. OVERALL CONTROL ALGORITHM

In order to fulfill all the principles discussed above, a supervisory control algorithm for providing reactive power compensation services by charging station equipped with FESS is designed in this section. The complete control diagram of the system is shown in Fig. 2.

A. DC/DC converter

A buck DC/DC converter is applied as EV charger following the control scheme provided by battery manufacturer which includes constant current and constant voltage charging stages. A typical control algorithm of buck-type DC/DC converter for battery comprises two nested control loops; inner current loop and outer voltage loop [17]. This part is not the focus of this paper.

B. Grid converter controller

A bidirectional PWM rectifier is used to connect to the grid, and the controller includes two control levels. The inner current loop is deployed in stationary frame. The reference of the inner loop is provided by the outer loop. The controller

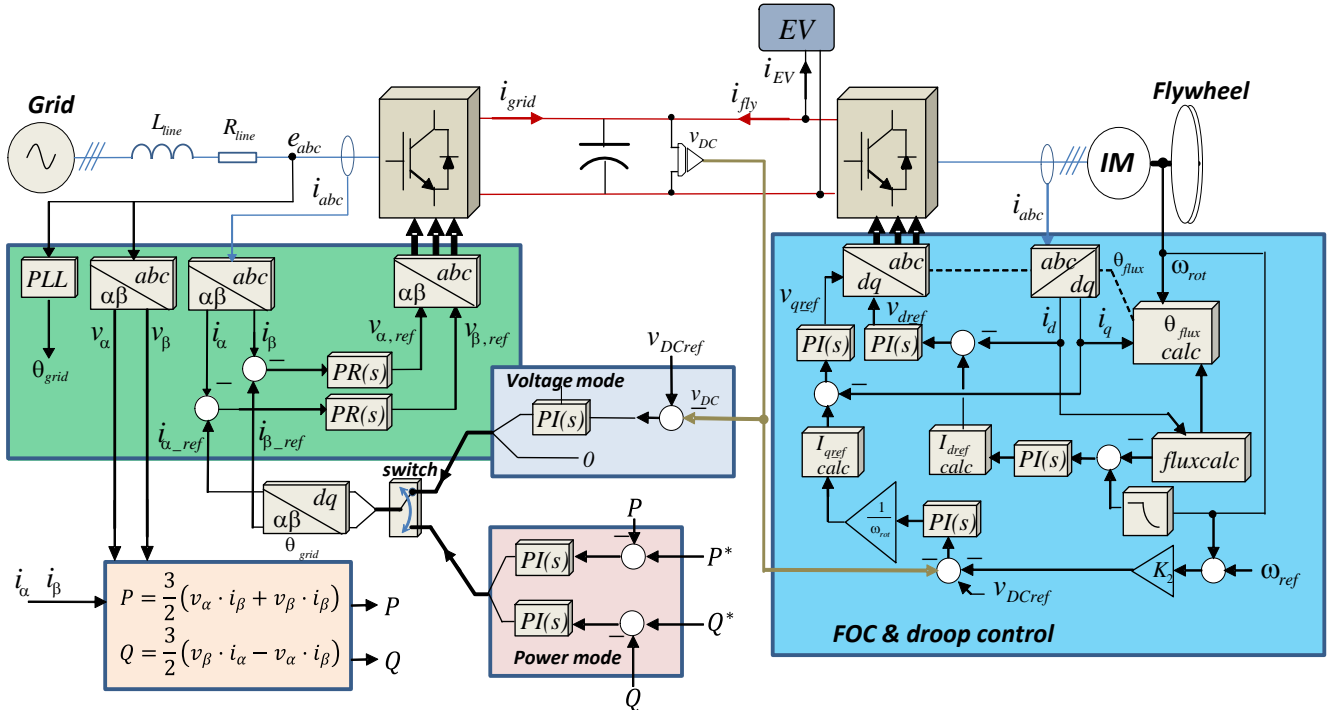

Figure 2. Full diagram of the FCS control system.

could operate in two modes:

1) Voltage mode: when there is no power command, the grid converter regulates the DC voltage and charges the flywheel.

$$\begin{cases} i_d^* = K_p (V_{dc}^* - V_{dc}) + \frac{K_i}{s} (V_{dc}^* - V_{dc}) \\ i_q^* = 0 \end{cases} \quad (1)$$

2) Power mode: If there is a power request from the EV user or DSO, the controller will follow the active and reactive power commands, and the flywheel regulates the DC voltage.

$$\begin{cases} i_d^* = K_p (P^* - P) + \frac{K_i}{s} (P^* - P) \\ i_q^* = K_p (Q^* - Q) + \frac{K_i}{s} (Q^* - Q) \end{cases} \quad (2)$$

In power mode, the control should follow the apparent power operation limit shown in Fig. 3. The active power reference is depending on the PEV battery pack size, the State of Charge (SoC), and the user choice for the charging type while the reactive power reference is directly received from the DSO.

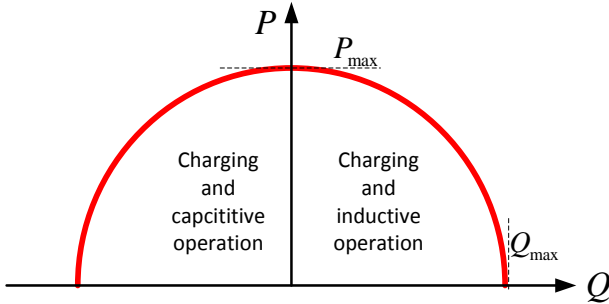

Figure 3. Available power operation region

C. Flywheel converter

The flywheel is driven by an induction machine (IM). The inner control scheme for IM adopts the indirect field oriented control (FOC), where d-axis and q-axis components correspond to flux and torque, respectively. The control model can be expressed as follows [18]:

$$\begin{bmatrix} \dot{i}_d \\ \dot{i}_q \end{bmatrix} = \frac{v_{DC}}{\sigma L_s} \begin{bmatrix} d_d \\ d_q \end{bmatrix} + \begin{bmatrix} -\frac{R_s}{\sigma L_s} & \omega_{mR} \\ \omega_{mR} & -\frac{R_s}{\sigma L_s} \end{bmatrix} \begin{bmatrix} i_d \\ i_q \end{bmatrix} - \frac{1}{\sigma L_s} \begin{bmatrix} 0 \\ \omega_{mR} \psi_r \frac{L_0}{L_r} \end{bmatrix} \quad (3)$$

where L_s , L_r , R_s , R_r are stator and rotor inductances and resistances, respectively and L_0 is the mutual inductance; ω_{mR} is the rotor speed, while ψ_r is the rotor flux; σ is the total leakage coefficient.

The d-axis stator-current reference is obtained using a flux controller and the rotor-flux position θ_r results from the rotor speed ω_m and slip speed. The q-axis stator current reference is computed from the torque reference, which is generated by the upper controller, where the DC voltage vs speed droop control is used to achieve a distributed bus signaling control. The flywheel can automatically regulate the DC bus by speeding up and down around the nominal speed.

$$T_{ref} = \left(K_p + \frac{K_i}{s} \right) \left((V_{dc}^* - V_{dc}) - K(\omega_m^* - \omega_m) \right) \quad (4)$$

Based on the control approach described above, the EV charging system can coordinate its operation according to different EV users' requests and grid power commands. When there is a reactive power command from DSO, the active power for EV extracted from grid is reduced, which lead to a drop to dc bus, while the flywheel compensate the active power to EV by reducing its rotation speed. When the power mode operation finished, the grid converter restart to regulate DC bus and charge the flywheel back to nominal speed. During this process, there is no necessary communication link between grid and flywheel controller and the flywheel coordinates its operation according to the DC bus variation.

IV. REAL-TIME SIMULATION RESULTS

A downscaled Real-time simulation is performed based on dSPACE1006 platform. A simulation scenario shown in Table II is developed to show the operation of the flywheel combined charging station and its response performance to grid commands. The supervisory control parameters of grid and flywheel controller are listed in Table III.

The simulation starts with only the charging operation, the EV is in constant current charging and the grid converter is in

TABLE II. REAL-TIME SIMULATION SCENARIO

Time/s	Grid controller mode	Active power /kW	Reactive power /kVAR	Apparent power /kVA	Flywheel operation
20-23	Power mode	33	0	33	Standby
23-28	Power mode	10	20	33	Discharging
28-32	Power mode	10	-20	33	Discharging
32-34	Power mode	33	0	33	Standby
34-46	Voltage mode	N/A	N/A	N/A	Charging
46-50	Voltage mode	N/A	N/A	N/A	Standby

TABLE III. ELECTRICAL PARAMETERS

Grid controller	
Voltage mode Proportional term	0.5
Voltage mode Integrator term	2
Power mode Proportional term	1.2
Power mode Integrator term	3
Time constant	1e-4s
Flywheel controller	
Droop parameter	0.05
Time constant	1e-4s

power mode. At 23s, DSO requests a 2.2kVAR inductive reactive power support from the CS, the active power from the grid is decreased to 10kW, hence causing a drop to DC link, then the flywheel speeds down and supplies the active power to the EV according to the droop law and consequently at 28s, the grid converter follows the DSO request of a 2.2kVAR capacitive reactive power. From 32s, the reactive power support stopped and the active power increase to 3.3kW. At 34s, the EV finishes the charging and thus, the grid converter switches to voltage mode and charges the flywheel back to nominal speed. Around 45s, flywheel is recharged back to full SoC.

Figs. 4 and 5 show the active power and reactive power of grid converter. The flywheel rotational speed is shown in Fig. 6. The DC current of battery, grid and flywheel converter are presented in Fig. 7. From the waveforms, it can be seen that the charging station is able to provide the reactive power support to the grid according to DSO command while the EV recharging process is not compromised in each operation mode with the compensation of the FESS.

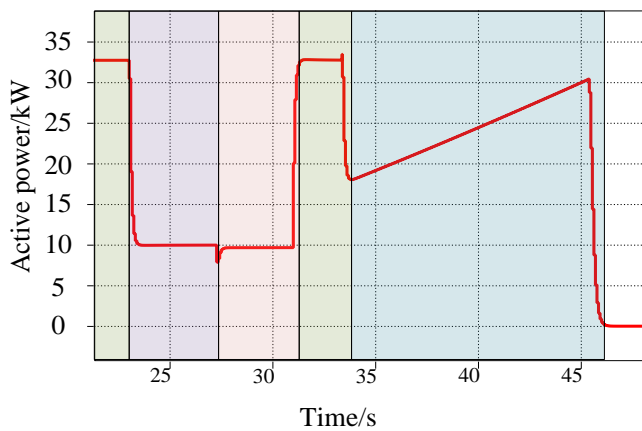

Figure 4. Grid converter active power

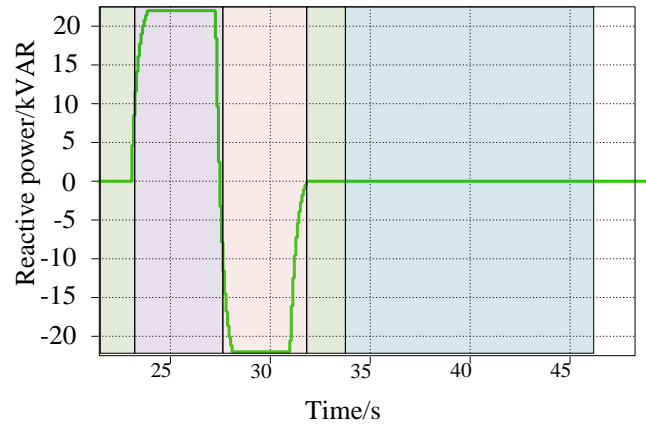

Figure 5. Grid converter reactive power

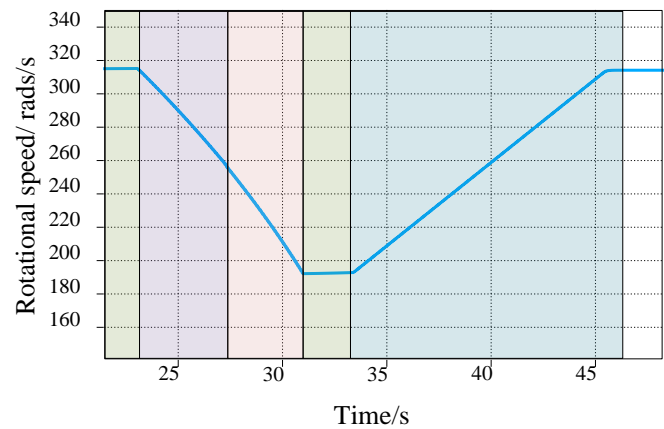

Figure 6. Flywheel speed

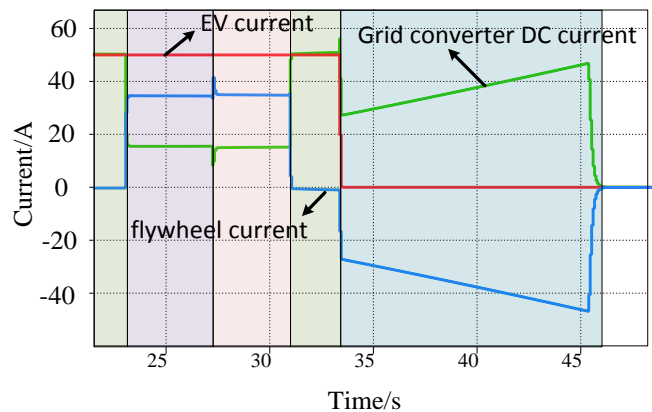

Figure 7. DC current of battery, grid and flywheel converter

V. CONCLUSION

A supervisory control algorithm for electrical vehicle fast charging station system is proposed in this paper to explore the ability of providing reactive power ancillary services to power grid. The specified contribution of this work is employing the flywheel energy storage system to compensate the active power for EVs during supplying reactive power services to the grid. The coordinated operation of grid and flywheel controllers is realized with a distributed bus

signaling method, hence there is no dependence on communication. Based on the proposed coordination control scheme, the CS can respond to inductive and capacitive reactive power commands without compromising the predefined charging profiles of EV battery. It preserves the lifetime of battery. Due to the FESS installation, the benefit of both EV user and grid operator can be respected. Real-time simulations were performed in order to demonstrate the effectiveness of proposed approach. Research that builds upon the results presented here is currently under way and includes implementation of the algorithm within the practical experimental setup with real converters and flywheel based on the setup in Intelligent Microgrid lab of Aalborg University.

REFERENCES

- [1] X. Chang, B. Chen, Q. Li, X. Cui, L. Tang, and C. Liu, "Estimating realtime traffic carbon dioxide emissions based on intelligent transportation system technologies," *IEEE Trans. Intelligent Transportation Syst.*, vol. 14, no. 1, pp. 469–479, 2013.
- [2] S. Kobayashi, S. Plotkin, and S. K. Ribeiro, "Energy efficiency technologies for road vehicles," *Energy Efficiency*, vol. 2, no. 2, pp. 125–137, 2009.
- [3] M. Ehsani, Y. Gao, and A. Emadi, *Modern Electric, Hybrid Electric, and Fuel Cell Vehicles: Fundamentals, Theory, and Design, Second Edition Power Electron. and Appl. Series*, Taylor & Francis, 2009.
- [4] M. Yilmaz and P. T. Krein, "Review of battery charger topologies, charging power levels and infrastructure for plug-in electric and hybrid vehicles," *IEEE Trans. Power Electron.*, vol. 28, no. 5, pp. 2151–2169, May 2013.
- [5] A. Khaligh and S. Dusmez, "Comprehensive topological analysis of conductive and inductive charging solutions for plug-in electric vehicles," *IEEE Trans. Veh. Technol.*, vol. 61, no. 8, pp. 3475–3489, Oct. 2012.
- [6] M. Hartmann, T. Friedli, and J.W. Kolar, "Three-phase unity power factor mains interfaces of high power EV battery charging systems," in *Proc. ECPE Workshop Power Electron. Charging Elect. Veh.*, Valencia, Spain, Mar. 21–22, 2011, pp. 1–66.
- [7] A. Kuperman, U. Levy, J. Goren, A. Zafransky, and A. Savernin, "Battery charger for electric vehicle traction battery switch station," *IEEE Trans. Ind. Electron.*, vol. 60, no. 12, pp. 5391–5399, Dec. 2013.
- [8] S. E. Letendre and W. Kempton, "*The V2G Concept: A New Model for Power?*", Reston, VA, USA: Public Utilities Fortnightly, Feb. 2002, pp. 16–26.
- [9] M. C. Kisacikoglu, "Vehicle-to-Grid (V2G) reactive power operation analysis of the EV/PHEV bidirectional battery charger," Univ. Tennessee, Knoxville, TN, USA, May 2013.
- [10] U. Madawala and D. Thrimawithana, "A bidirectional inductive power interface for electric vehicles in v2g syst.," *Ind. Electron., IEEE Trans. on*, vol. 58, no. 10, pp. 4789–4796, 2011.
- [11] E. Sortomme and M. El-Sharkawi, "Optimal scheduling of vehicle-to-grid energy and ancillary services," *Smart Grid, IEEE Trans. on*, vol. 3, no. 1, pp. 351–359, 2012.
- [12] M. C. Kisacikoglu, B. Ozpineci, and L. M. Tolbert, "EV/PHEV bidirectional charger assessment for V2G reactive power operation," *IEEE Trans. Power Electron.*, vol. 28, no. 12, pp. 5717–5727, Dec. 2013.
- [13] Kesler, M. ,Bilecik, Turkey, Kisacikoglu, M.C., Tolbert, L.M. "Vehicle-to-Grid Reactive Power Operation Using Plug-In Electric Vehicle Bidirectional Offboard Charger", *IEEE Trans. Industrial Electronics*, vol 61, no. 12, pp. 6778-6784, Dec, 2014.
- [14] T. Dragicevic, S. J. C. Vasquez, J. M. Guerrero, "Flywheel-based distributed bus signalling strategy for the public fast charging station," *IEEE Trans. Smart grid*, vol. vol.PP: no.99. 1-11, 2014.
- [15] J. Schonberger, R. Duke, and S. Round, "DC-Bus Signaling: A Distributed Control Strategy for a Hybrid Renewable Nanogrid," *Ind. Electron IEEE Trans. on*, vol. 53, pp. 1453–1460, Oct. 2006.
- [16] *Revolutionizing Fast Charging for Electric Vehicles*, Intel, Santa Clara, CA, USA, Jul. 2013.
- [17] T. Dragicevic, *Hierarchical Control of a Direct Current Microgrid with Energy Storage Systems in a Distributed Topology*. PhD Thesis, 2013.
- [18] R. Cardenas, R. Pena, G. Asher, J. Clare, and R. Blasco-Gimenez, "Control strategies for power smoothing using a flywheel driven by a sensorless vector-controlled induction machine operating in a wide speed range," *Industrial Electronics, IEEE Transactions on*, vol. 51, no. 3, pp. 603–614, 2004.