



AALBORG UNIVERSITY
DENMARK

Aalborg Universitet

Sustainability evaluation of societies - Work energy accounting and Carbon balance

Nielsen, Søren Nors; S.E., Jørgensen,

Publication date:
2014

Document Version
Early version, also known as pre-print

[Link to publication from Aalborg University](#)

Citation for published version (APA):
Nielsen, S. N., & S.E., J. (2014). Sustainability evaluation of societies - Work energy accounting and Carbon balance: A case study of the island of Samsø. Samsø Energiakademi/VELUXFONDEN.

General rights

Copyright and moral rights for the publications made accessible in the public portal are retained by the authors and/or other copyright owners and it is a condition of accessing publications that users recognise and abide by the legal requirements associated with these rights.

- ? Users may download and print one copy of any publication from the public portal for the purpose of private study or research.
- ? You may not further distribute the material or use it for any profit-making activity or commercial gain
- ? You may freely distribute the URL identifying the publication in the public portal ?

Take down policy

If you believe that this document breaches copyright please contact us at vbn@aub.aau.dk providing details, and we will remove access to the work immediately and investigate your claim.

Sustainability Evaluation of Societies – Work Energy Accounting and Carbon Balance

A case study of the island of Samsø, Denmark, year 2011

Sustainability Evaluation of Societies Work Energy Accounting and Carbon Balance
- a case study of the island of Samsø (Denmark) year 2011

© Samsø Energy Academy

Frontpage photo:

Malene Annikki Lundén

ISBN: 978-87-92274-03-8

Research team and text:

Søren Nors Nielsen, +45 32581316 or +45 24483316 (mobile)

soerennorsnielsen@gmail.com

Svend Erik Jørgensen, +45 44480600

msijapan@hotmail.com

Design and layout:

Gitte Larsen, Editions/House of Futures

Samsø Energiakademi

Strandengen 1

DK - 8305 Samsø

Tlf. +45 8792 1011

E-mail: info@energiakademiet.dk

Web: www.energiakademiet.dk

Developed with support from the VELUX FOUNDATION

June 2014

Content

Foreword	5
SUSTAINABILITY ANALYSIS AND CARBON BALANCE ON SAMSØ YEAR 2011	6
1. Introduktion	7
2. Sustainability of a society	7
2.1 How to define and assess sustainability	7
2.2 How to comprehend work energy	8
2.3 Sketching the method	9
3. Standardization of method	9
4. Work energy in the sectors	12
4.1 The Energy Sector	13
4.2 The public sector	14
4.3 The private (household) sector	15
4.4 Agriculture, Forestry and Fisheries	15
4.4.1 Production of crops	16
4.4.2 Livestock production	17
4.4.3 Forestry and fishery	17
4.5 Industry, commerce and trade	17
4.6 Nature	18
4.7 Wastes	18
4.8 Work energy - balance of 2011	19
4.9 Aiming at sustainability	21
5. Main conclusions and recommendations	24
CARBON CYCLING SAMSØ 2011 – CO ₂ EMISSION AND CARBON BALANCE	26
1. Introduction	26
2. Carbon model	26
3. Application of the model	27
4. Carbon balance for Samsø	30

Foreword

Samsø's carbon balance is positive!

There is an imbalance in the world, and temperatures are rising. The world community is worried. Too much CO₂ is emitted. People are calculating and trying to work out plans for how to turn around our energy consumption and reduce CO₂ emissions. The world needs solutions.

In 2013, Samsø in collaboration with Søren Nors Nielsen and Sven Erik Jørgensen and with support from the VELUX Foundations has produced a carbon account. The account shows that Samsø is capable of binding almost 40.000 tons of carbon per year. What is new in calculating a carbon model instead of a CO₂ balance?

Carbon is mineralized CO₂ and is a fundamental building block in biological growth and transformation. CO₂ is transformed into carbon when plants grow and thereby bind CO₂ in biological growth. We trade with the world we are a part of, and we export carbon in the form of our primary production of agricultural products, but also in the shape of manufactured goods in which carbon is bound. We of course also import goods and services which contain carbon, but when all is said and done and we calculate the terms of exchange, Samsø is capable of binding more carbon than we consume. We already knew that our CO₂ emissions on Samsø are negative due to the fact that we produce more CO₂ neutral energy than we consume. For most citizens this surplus is quite abstract, and for the ordinary citizen it is not possible to transform this CO₂ surplus into realizable market value. It is, however, good for Denmark and a positive assertion which supports the vision of a CO₂ neutral society.

Carbon, on the other hand, is highly valuable for an agricultural society like Samsø. The "health" of the farm land very much depends on how much biomass/carbon is bound in the soil, especially in the top soil. The soil's ability to bind water and nutrients increases as carbon levels increase. The agricultural sector can thereby save money on costly fertilization with positive results for the plants which become both healthier and more plenteous. By focusing on a "commodity" in this way, it becomes much more interesting for a society to bind CO₂ as carbon in the ground. This means a more convincing bottom line as well as a better climate for the earth.

The project has involved the Municipality of Samsø, the island's agricultural sector and the citizens of Samsø. It has furthermore been demonstrated to other island communities and regions. The energy account of the future has won an extra dimension and a far more transparent societal significance. Denmark's long-term Energy Strategy is to be independent of fossil energy sources by 2050. Samsø strives to become a fossil free society already by 2030. The carbon model will be a valuable tool in the realization of this visionary plan.

Søren Hermansen, director
Samsø Energy Academy

Sustainability analysis and Carbon balance on Samsø year 2011

This summary presents the main results of a project supported by the VELUX FOUNDATION and carried out at Samsø Energy Academy. The summary contains two parts. The first part focuses on a sustainability analysis and the second part on the carbon processes, carbon cycling and carbon balance of the island.

The sustainability analysis uses the concept of work energy as basis for the sustainability assessment. Both the energy and material flows can be expressed as renewable or non-renewable work energy and based on (work) energy units. By the developed method it is possible to assess whether the development in a given area – in this case the island of Samsø – is sustainable, and furthermore to identify what is needed to make the development more sustainable. The method can also be applied to express how much a project proposal – for instance to introduce electric cars on the island – will contribute in bringing the development of the island closer to complete sustainability.

The carbon cycling analysis summarizes all the main carbon processes in a carbon cycling model to permit an assessment of the total net emissions of carbon dioxide and methane from the island and to derive the input-output balance of carbon for the island. Samsø has introduced renewable energy but this does not ensure that the carbon dioxide emission is zero, because carbon participates in many processes, photosynthesis, decomposition of organic matter, consumption of food by humans and domestic animals and so on. Therefore, the construction of a model which includes all the main carbon processes is necessary in order to reveal the net emissions of carbon dioxide and methane together with the total carbon balance. The carbon cycling model can be applied to quantify the emissions and the carbon balance at a given point in time, and to evaluate how much they might be changed by a given project proposal, for instance by the introduction of electric cars on the island.

1. Introduction

This report describes the development of a method with the scope to account for, evaluate and monitor the level of sustainability of a society, such as a municipality, a region or a whole country.

The method has been developed taking a starting point in the situation on the Danish island of Samsø, widely known for its efforts in connection with a project named "Sustainable Energy Island", which started in 1997. During this project the inhabitants have succeeded in making the island self-sufficient in energy which is mainly produced by 21 on- and offshore windturbines at the island. At the same time part of the domestic heating previously supplied by oil furnaces has been replaced by district heating plants based on the burning of biomass and photothermal solar energy.

Meanwhile, the island still has a significant import of fossil fuels necessary to maintain essential functions such as the ferry services and other transports of goods to and from the island, transport on the island itself, and domestic heating in areas which are not covered by renewable energy supplies. As fossil fuels are finite, non-renewable resources it is assumed that the island someday will have to replace these by non-fossil resources if the same level of activity is to be sustained.

Thus – in spite of the intensive investments in renewable energies – the island still has some way to go before it can be considered fully sustainable.

2. Sustainability of a society

It will be advantageous to develop an accounting methodology on a clearly delimited system. In this respect an island seems to be ideal as it is relatively easy to overview the amounts of energy imported to the island, the energy necessary to maintain the function of the society, and the prevailing structures in which the energies eventually are used.

Meanwhile, the fact that one is working on a simplified and delimited society carries the risk of oversimplification, so that the method developed will be lacking in generality. In other words the simplification entails that the method may be too specific and that it will be necessary to refine and adapt it before it is possible to apply or extend it to societal systems on larger scales or different living conditions.

2.1 How to define and assess sustainability

It is clear that the statements found in the Brundtland – report about sustainability – to be the guarantee that future generations will have the same possibilities of unfolding their life as we have at present - does not bring us very far towards a

more exact definition of the word. Is it for example meaningful to say that we must pass on a world system based on exactly the same values and technologies which we have used ourselves? Would it not be better to take other measures now that we are already aware that many of our resources are close to being exhausted?

True sustainability can only be achieved in a society which in the base of its existence has been liberated from dependency on finite resources. This can be done by either not using them or by using them at the same rate as with which they are renewed, i.e. to recycle them completely using energy supplied by renewable sources.

There are two problems here which need to be clarified in order to identify a route towards sustainability. First of all it is necessary to determine whether a given resource under consideration is renewable or not - and next to find out the relationship between the resource and the energy needed for its recirculation. Here it becomes important to be able to compare the energy and matter fluxes of our society in order to weigh them against each other.

2.2 How to comprehend work energy

It is possible to define all resources, i.e. both energy and matter, in terms of the same unit by calculating them in terms of their respective work energy content. According to one of the most fundamental laws of physics and nature, energy can neither be created nor destroyed but is conserved. Energy may however be divided in two categories: one for energy which can perform work and another for energy forms which can deliver no or only little work. The first category includes for example oil or electricity used for heating - the second can be exemplified by the heat subsequently lost from our buildings during winter and heating the great outdoors.

At the same time another even more important law states that 1) all activities will need work energy, and 2) that activity inevitably occurs at the expense of work energy, so that part of the work energy is broken down and lost as heat which cannot be used any longer. This is also happening every time we transform one energy form to another, for instance when the chemical energy bound in coal is converted to electricity in power plants.

Thus, work energy is the fraction of a given amount of energy which is able to perform work, regardless whether it is bound in or derived from energy or matter. It is the work content we really should be interested in and use as well as possible in order to run our society in a more optimal manner. Meanwhile, we do not only exploit the work energy in wind through our exploitation of wind power, and in solar energy through photo-voltaics, but we also use the chemical energy which is bound in coal and oil to run machinery which make electricity and heat.

Society is interested in and dependent on work energy because it is necessary to our everyday life, our cars, refrigerators, washing machines, engines and industrial processes. Therefore, it would be much more interesting to set up an accounting system for society in terms of work energy than to use the normal energy accounting systems, which also include energies that may not be used for anything. Likewise, conventional energy accounting does not take into consideration the quantities of work energies which are lost - to a greater or lesser extent - through the energy transformation which occurs when we exploit energies for various activities. In other words, it is important that we get as much work energy as possible out of the energies we use - and that as little as possible is lost as waste heat to the surroundings.

2.3 Sketching the method

In this sustainability analysis we describe all the energy and matter flows which enter our society, circulate (cycle) in it and eventually leave it as wastes. By accounting for the flows in terms of work energy we get the advantage that they are now expressed in the same unit, namely the unit of energy, e.g. kJ or kWh. We can now compare their values and may divide the flows according to whether we consider them to be based on renewable or non-renewable resources, i.e. to be sustainable or not.

Having accounted for energy and matter flows in this manner we will be able to identify areas of activity where large amounts of work energy are consumed and where work energies are exploited with a very low efficiency. In such areas it would be logical to take measures in order to improve the exploitation of the work energy. This is yet another reason why work energy accounting is so important.

3. Standardization of the method

This accounting method for measuring societal sustainability has been developed with a view to making it as universal as possible, i.e. to make it applicable to most societies and/or levels of society. Thus, the issue of universality means that the method must relate to a partitioning of the society that is recognizable in most societies. At the same time the data needed for the analysis ought to be available or easy to deduce from existing data sources. In this respect we have considered the ways data are organized in the Danish society, since this should also make the implementation possible in most other European countries. A major assumption that has been made is that all societal activities of today are reflected to a large extent in the amount of space they take up and thus can be related to spatial and geographical data.

A) STANDARD PARTITIONING OF THE SOCIETY

A standardized way of partitioning the society takes its starting point in sectors which we normally recognize as parts of our societies.

- An energy sector which ensures the delivery of the types of energies needed to maintain our activities.
- A public sector, which sees to the practical implementation of laws and takes care of the citizens by offering a variety of services.
- This component is as opposed to the private household sector where the citizens take care of their own existence in the form of individual persons or families.
- In addition most societies have an agricultural sector which in this context has been widely interpreted as all production activities which in some way are dependent on natural resources. This therefore includes crop and livestock production, forestry and fisheries.

Figure 1.1

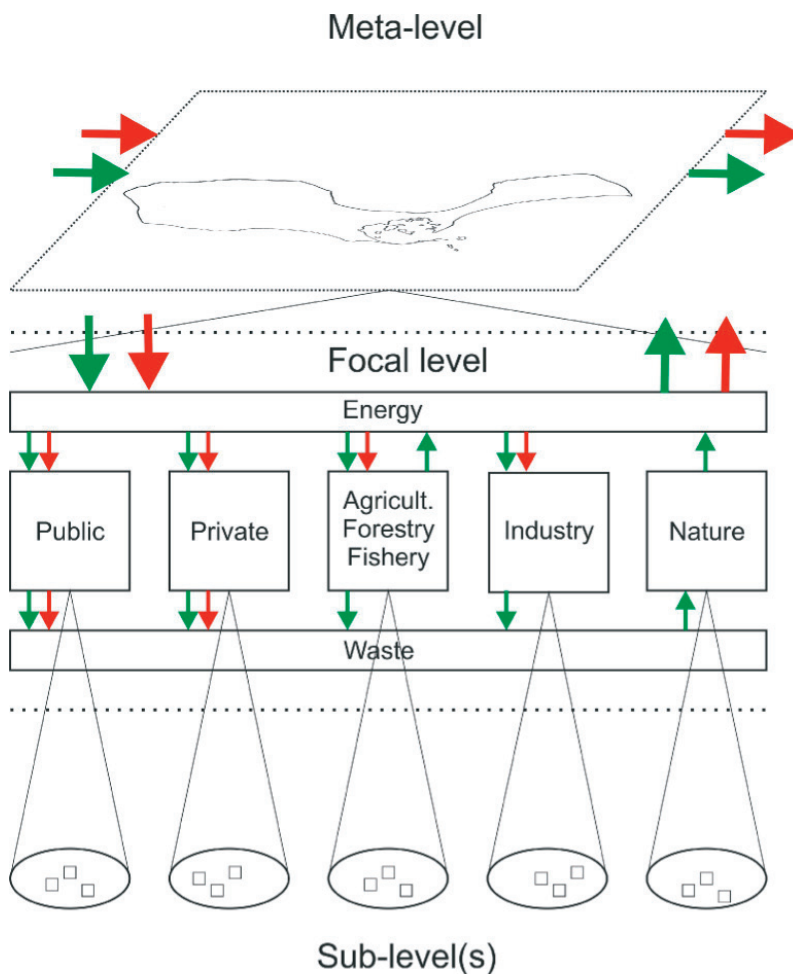

The figure shows how the island of Samsø has been divided into sectors which together are considered to comprise all societal activities. An overall energy accounting has been carried out since 1997 which has served as an entry point to this study. Meanwhile the sectors contain a number of material flows which need to be taken into account in a sustainability analysis.

- An industrial sector which comprises all other activities - from industry proper to commerce and trade - in principle all activities not included in the public or agricultural sectors
- Nature is viewed as being a sector on its own which thus covers the “natural capital” of the society. This sector contributes to a wide extent to the maintenance of society by a variety of activities known as “eco-system services”, - activities carried out by nature which provide basic prerequisites of human life and which are therefore important for keeping our societies running.

B) STANDARDIZING DATA COLLECTION

In the construction of this method - which aims at making a sustainability evaluation of societies based on work energy accounting - a starting point has been taken in various existing systems and databases. Furthermore, information has been procured from reports and special literature in the area.

Most European countries base their spatial information on the legislation given by EU laws and directives according to which the landscapes are described by a number of codes used to assign specific societal activities to certain individual parts of the landscape (cf. CLC, Corine Landscape Codes). Meanwhile, the spatial resolution of the landscape in the latest inventory carried out around 2006 is not good enough to permit reliable calculations for smaller municipalities. Luckily, the partitioning and resolution of the landscape as presented by most of the maps in the geographical information systems (MapInfo, ArcGis) used by Danish municipalities today to a large extent utilize the same or similar classifications as used in the CLC-system. Using these data and the resolution found here a sufficiently detailed accounting can be achieved.

In addition, a large amount of information on the sizes and areas occupied by buildings together with their uses has been gathered from the authorities (in Denmark the registry of Buildings and Residences, BBR), and the registry of properties (ESR) from which information on area and usage types has been obtained.

A large amount of data concerning agricultural and industrial activities is reported to the various responsible authorities, - the Ministry of Food, Agriculture and Fisheries and the Ministry of Environment from which land use, areas, use of resources and information about green accounting systems may be obtained.

Most information obtained from these sources, although important, is also insufficient, so more information has to be gathered from other sources to permit a full evaluation on a work energy basis. This concerns for instance the description of the many different practices in agriculture in relation to crops and livestock, the use of internal vs. external materials, their respective contents of work energy, etc.

Exact knowledge about the infrastructure of our society, such as information on the material composition of buildings as well as their respective contents of work energy is not always easily obtained and searching for this information may be a rather time consuming process.

The area of information gathering needs optimization. In the section of conclusions some measures are proposed in order to improve and facilitate future analysis of sustainability in societies.

4. Work energy of the sectors

In order to determine what activities are responsible for the largest uses and consumptions of work energy it is necessary to work out a more detailed accounting system for each of the above-mentioned sectors.

Their respective sizes are made up by the necessary infrastructure which must be maintained in order to carry out its function(s) in a successful manner for

the sector. This infrastructure can be considered a “cultural capital” of work energy which has been built up by our society.

Next, it is necessary to have a work energy input to drive each of the sectors together with its respective functions. A detailed accounting makes it possible to evaluate the different consumptions against each other. Most attention should of course be paid to the larger of the consumptions. In turn consideration should then be given to ways in which large amounts can be reduced and the same level of activity retained. This means maintaining the same structure and service for a lower price in terms of work energy consumption.

The same considerations should be made for all work energies leaving the sectors. Most often these work energies are considered to be lost, but an evaluation should be made of the possibilities for exploiting the remaining work energy content in other activities should be considered. For example the temperature level of waste heat will determine if it is beneficial to use it as input to other processes for instance through heat exchange. Similar considerations may identify measures for

Figure 1.2

A work energy inventory of the energy sector, imports, exports, consumptions on the island of Samsø in the year 2011. A slash separates values of energy/work energy.

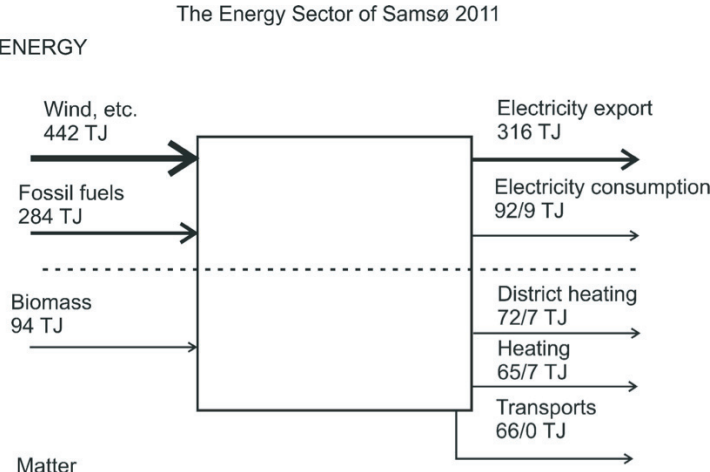

internal recycling and possibilities for exploitation of exports by the surroundings. The latter will help to increase the sustainability in other parts of the society under consideration or in adjacent societies.

4.1 The energy sector

Work energy analysis of the energy sector on Samsø immediately reveals this sector to be relatively sustainable since the major part of the energy used on the island is derived from electricity produced by the 21 wind turbines on and around the island. There is a net positive electricity production and the surplus is exported from the island to the national network. Meanwhile, the island still has a relatively

Figure 1.3

A work energy inventory similar to the one shown in Fig. 1.2 but demonstrating the situation in 1997 – at the beginning of the sustainable energy island project.

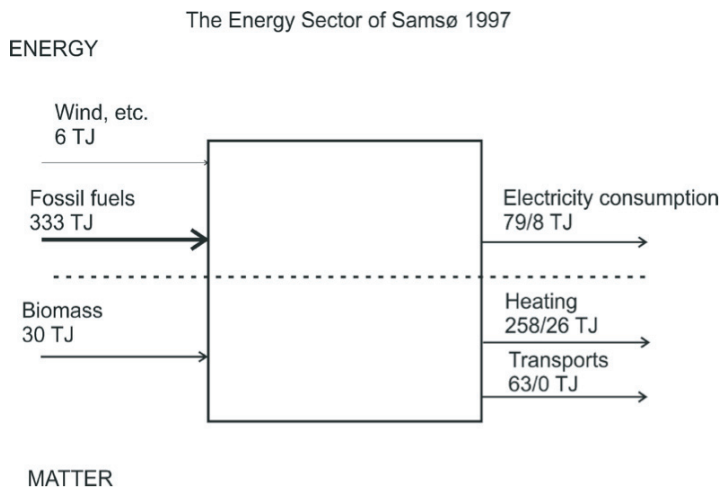

Figure 1.4

The work energies of the public sector of the island of Samsø in 2011 – the presentation is analogous to the previous figures.

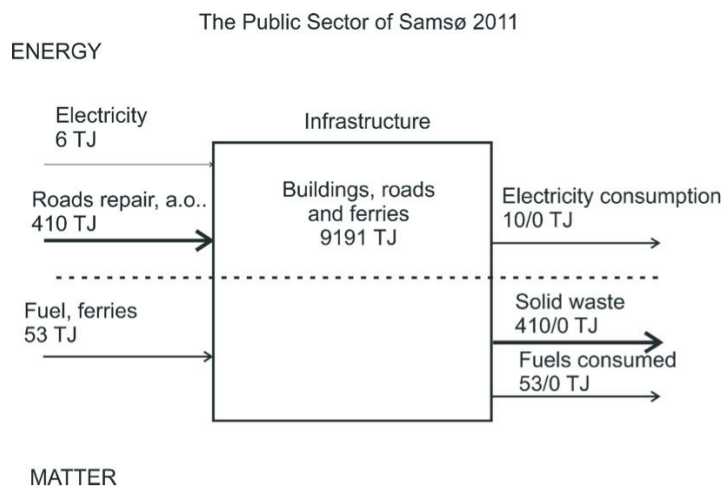
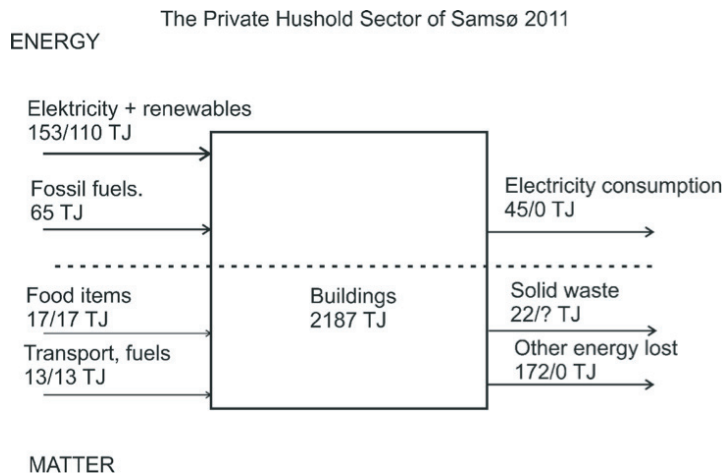

Figure 1.5

The work energies of the private household sector – same indication as previous figures.



large import of fossil fuels, such as oil, diesel and gasoline, which are mainly used for heating houses in the remaining oil-fired boilers, and for transports to and from the island and on the island itself.

The total work energy used to drive the energy supplies of the island in 2011 sums up to 820 TJ of which the 284 TJ are still derived from fossil fuels, i.e. 65% of the energy imports are supplied from renewable sources.

In the figures the upper half is dedicated to work energies bound in what we traditionally refer to as energy - whereas the lower half shows work energy forms which are bound in materials. In the numbers a slash is used to separate energy and work energy values.

Over the years from 1997 to 2011 the island of Samsø has improved its energy efficiency proper from 60% to 81% based on output/input considerations, while the efficiency expressed in terms of work energy has increased from 5% to 40%.

Here it becomes clear that such a work energy budget does not take into consideration the work energy contents of material fluxes. Therefore, in order to complete the sustainability evaluation, we need to expand the energy balance of the island with the following considerations.

4.2 The public sector

The work energy in the necessary (existing) infrastructure is relatively small (368 TJ). The estimation of this number is based entirely on permanent structures, that is buildings, as it has not been possible within this project to retrieve information on the less permanent parts such as for instance vehicles owned by the municipality.

When including transport-related facilities, such as ferries (710 TJ) and roads (8113 TJ), in the accounting one gets quite a different picture. The renewal of tarmac roads is based on non-renewable resources, so clearly this issue should receive some attention in the future if the island is to be freed of its dependency on fossil fuels.

Operating the structure requires a yearly input of 473 TJ corresponding to approximately 5% of the entire structure. This number does not include any con-

siderations about the necessary renewal of roads and ferries.

Under all circumstances the public sector will most often appear to be an inefficient part of the society as its "products" do not represent any tangible values which can be expressed easily in terms of work energy. The sector as such has a high consumption for maintenance and an output of work energy with a value close to zero (0).

4.3 The private (household) sector

This sector comprises a considerable amount of infrastructure in form of domestic dwellings and associated buildings. This part has been estimated to amount to 2187 TJ. On Samsø a number of buildings only used for a minor part of the year must be included. If a yearly rate of renewal of houses of 1% is assumed one gets a relatively high maintenance inputs required by this sector year after year to ensure its persistence in the future.

The private sector is on the one hand driven by a supply of energy as electricity (45 TJ) and heat (65 TJ) which in the case of Samsø mainly stems from heating plants driven by either the public or some joint ownership enterprise. In terms of materials there must be a series of necessary goods such as furniture and other consumables for which data have not been identified.

At the same time the private household sector consumes a relatively large amount of fossil fuels corresponding to approx. 78 TJ of which its transportation requirements amount to 13 TJ. The energy imported to this sector which may be considered to arise from renewable resources is estimated to 128 TJ out of a total of 202 TJ meaning that the inputs are based on 63% renewable resources.

As with the public sector, it does not make sense to calculate an output/input efficiency of this sector since the major part of the imported work energy must be regarded as lost: it is broken down to thermal energy at about the same temperature as the surroundings.

The only work energy outputs which potentially could have some value seems to be contained in the various pools of solid wastes which leave this sector. The amount of organic materials available for biogas production, for example, is estimated to be approx. 22 TJ per year.

4.4 Agriculture, Forestry and Fisheries

The activities undertaken by the agricultural sector on the island occupy a major part of the landscape. Around 75% of the area of the island is officially registered as farm land. Forestry as activity on the island is considered to be extensive in character, so the calculation of this contribution has been included in "nature".

For reasons of convenience the estimation of work energies in agriculture has been separated in two main activities (sub-sectors) namely - crop and livestock production. In terms of calculation the two do not share much in methodological background - neither when considering the retrieval of the necessary data nor in establishing the equations used for calculation of their respective contributions.

To some extent it has been necessary to rely on theoretical and not actual values. Thus the calculation of seeds, crop outcomes, consumption of fuels for soil handling, as well as the use of artificial fertilizers (N, P, and K) had to be calculated from standard data mainly given in the cultivating instructions by the farmer's organizations. Pesticide usage is estimated from the Danish statistics in the area

published by the Danish Environmental Protection Agency (da.: Bekæmpelsesmid-
delstatistikken) describing the overall usage by the farmers in 2011. The same
holds for livestock production where a diversity of handbooks from the publisher
Landbrugsforlaget turned out to be valuable sources.

The use of actual values was not possible due to time limitation as it was
found that the databases available are not designed with a view to assisting the
project's aim of carrying out estimates of sustainability. Extraction of data would
therefore have been very time consuming.

The data retrieved are at present only available as a number within rather
complex spreadsheets. It is considered that it would be beneficial to organize this
knowledge in a proper database from which data could be recovered with relative
ease. This would also be an advantage for potential future users in terms of a data-
guided overview.

4.4.1 Production of crops

On the island of Samsø the farmers produced in 2011 approx. of 80-90 crops out of
the 250 types listed in the codes given in the homepages of the Danish Veterinary
and Food Administration under the Ministry of Food, Agriculture and Fisheries.

The production of the various crops demands a series of inputs which have
been estimated for the island in 2011 to be: seeds (30 TJ), electricity (19 TJ) and fos-
sil fuels (31 TJ). Artificial fertilizers (only N, P, K are considered) and pesticides are
estimated to be used in amounts corresponding to 52 and 5 TJ respectively. Thus
the total work energy consumed in crop production is 137 TJ.

For this investment the theoretical outcome can be calculated to result in an
above ground biomass corresponding to 3388 TJ. Thus the overall outcome of crop
production is a result of solar radiation which as a minimum is approximately in
the same order of magnitude (3357 TJ) - calculated as harvested biomass less the
seeds invested to make the respective crops.

The biomass produced represents a value in terms of work energy which is

Figure 1.6

The work energies of the crop production sub-sector of agricultural production on the island
of Samsø 2011 – analogous to previous figures.

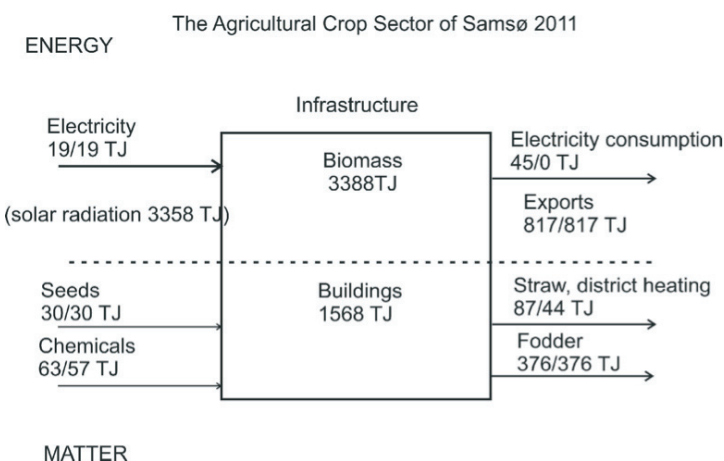

twice the value of work energy bound in production facilities, buildings, barns and stables which has been estimated to 1568 TJ.

Out of this an amount of 817 TJ is assumed to leave the island as more or less manufactured goods - not including non-processed goods the amount of which are likely to be larger. Likewise it is estimated that 375 TJ of the output is used as fodder for the livestock production on the island.

Since a relatively large amount of the total inputs to the sector - in total 3494 TJ - is derived from renewable resources; - non-renewable resources account for only 87.6 TJ out of the total - the sector appears very effective. Still, the amounts of non-renewable energies are not insignificant as they are of the same order of magnitude as many of the other consumptions of the island.

4.4.2 Livestock production

Livestock production on the island consists mainly of pig and cattle production which is responsible for almost 100% of the livestock number and mass on the island.

The work energy contained in the stocks is estimated to be around 40 TJ. Assuming that this amount is produced with an amount of work energy which may be derived from handbooks of livestock production one may estimate a required amount of work energy of fodder of 375 TJ fodder and 9 TJ of other energies. It is likely that around 10% of the yearly stock production is retained to ensure further breeding and production. The part of the production leaving the island corresponds to around 10% of the work energy supplied to this sub-sector. Milk production is calculated to be responsible for approx. 2.4 TJ.

4.4.3 Forestry and fishery

As mentioned the forestry activities on the island seem to be of a low intensity (extensive) type, and is thus considered under the estimation of work energy in nature. At the same time the part of the area of forest on the island actually reported as being commercial is so small that it is considered to be of no importance to the work energy budget of the sector. Fisheries are of no importance to the island any more as only leisure fishing activities take place today. A method needs to be developed for calculating the work energies of fishing activities for societies where the activities of this sub-sector are of importance.

4.5 Industry, commerce and trade

The infrastructure of the island considered belonging to the activities grouped under industry, commerce and trade has been estimated to 753.6 TJ which corresponds to approx. 15% of the work energy of the buildings. The amount is twice the work energy of the public sector but only one third and half the values of private households and agricultural crop sectors, - respectively.

Since a great proportion of the work energy consumption occurs in connection with the production of processed food at the factory Trolleborg the activities of this enterprise come to dominate the results of this analysis. The sector has a total consumption of material, chemicals and raw products from the crops of around 118 TJ, out of which 41 TJ (35%) must be considered to have their origins in non-renewable resources (mainly packaging materials).

Since much of the work energy supplied to the industry also leaves the system in the form of work energy which is still useful (possibly an increase in work

Figure 1.7

Work energies of the Industry, Commerce and Trade sectors of the island of Samsø in 2011 – analogous to previous figures.

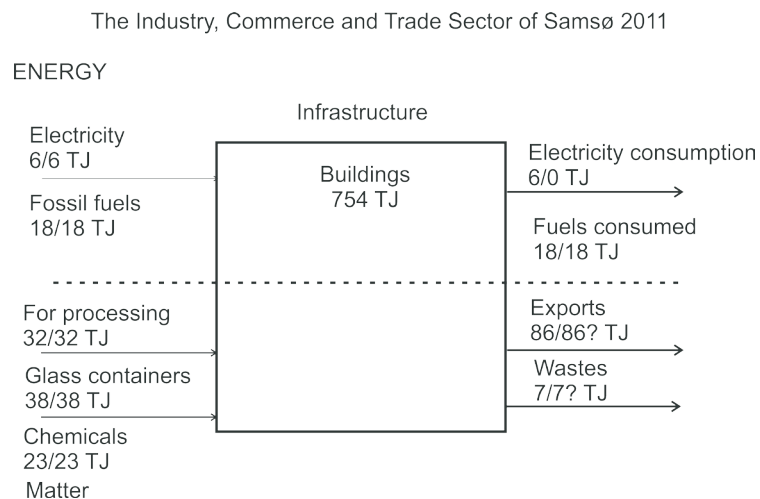

energy) the activity undertaken by this sector appears to be sustainable when output/input efficiency is calculated on a work energy basis.

The wastes from this sector which may possibly be used for biogas production are estimated to lie between 7 and 48 TJ, which is of the same order of magnitude as the organic part of the wastes from the private household sector. An amount of 7 TJ is today returned to the fields of the island.

4.6 Nature

Samsø has a considerable amount of natural areas which are of great value to the inhabitants but also must be assumed to be an important attraction to the tourism on the island. The natural areas comprise important ecosystems and a variety of smaller biotopes which are considered important to preserve because they act as buffer zones between agriculture and areas of habitation. Furthermore, the natural areas on Samsø offer a variety of contributions which are beneficial to our society and known as Ecosystem Services. Part of the coastal nature is protected as a Natura 2000 reserve comprising Besser Rev, Stavns Fjord and the adjacent part of Kattegat.

The total work energy incorporated in nature - "the natural capital" - is estimated to 6562 TJ. This work energy stems from and is maintained by a yearly contribution from photosynthesis of around 416 TJ - which corresponds to a Stock/Input efficiency ratio of 16. This means that nature represents a high amount of structure or biomass which is maintained by a relatively small import, i.e. primary production. This is in part due to the relatively large areas of forests on the island which have a high amount of standing crop.

4.7 Wastes

Although it was not originally part of the plan to make any evaluation of the situation relating to wastes on the island, the decision was taken - after identifying a reliable source of data - to make a preliminary accounting of the potential avail-

ability of this resource on Samsø. Waste was not at first considered interesting as in 2011 it was exported from the island to be incinerated on the mainland. Since then, with the initiation of various discussions about becoming an island free of fossil fuels, converting the ferries to run on more environmentally friendly, renewable resources, and constructing a biogas plant, it has become clear that wastes could play a central role in these plans.

Solid wastes are estimated to represent a total of around 187 TJ. A smaller part is considered to be of potential use in biogas production (approx. 32 TJ) together with an amount of garden waste of 8 TJ. These estimates together are around twice the contribution from the private households.

4.8 Work energy - balance of 2011

The work energies imported and necessary to run the society on Samsø in 2011 and the subsequent exports of work energy and goods can be aggregated to give a total budget of the island in a diagram (see Figure 1.8). Here all energy and material flows are shown - work energy bound in energies in the upper half and work energy bound in materials in the lower. Both types have been subdivided into renewable and non-renewable contributions. Inputs are shown to the left and outputs to the right.

It is seen that the societal infrastructure (stock) - in this case mainly buildings and roads - has been estimated as making a relatively large contribution of

Figure 1.8

A gross accounting of work energies (WE) of Samsø in 2011 where flows have been aggregated in REBEI: renewable energy bound WE in inputs, NEBEI: non-renewable energy bound WE in inputs, RMBEI: renewable matter bound WE in inputs, NMBEI: non-renewable matter bound WE in inputs, EBI: summed WE in energy inputs, MBI: summed WE in matter inputs. The acronyms on the right hand side have similar meaning - where I is replaced with an O - signifying the output. The figure likewise gives totals and divides resources into renewable and non-renewable inputs and outputs, respectively.

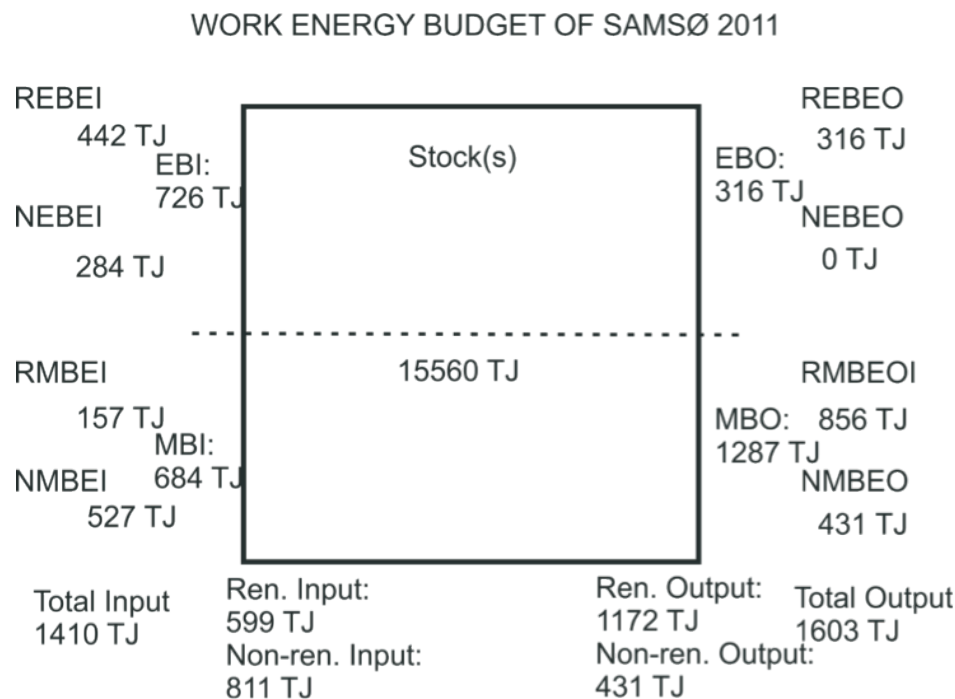

15560 TJ. This infrastructure requires maintenance, but the calculations only include considerations on the requirements for renewal of roads as this pool is assumed to be most significant.

The figure shows that energy is the predominant driving force of the society since this part of work energies has been estimated to 726 TJ compared to the 684 TJ supplied in materials. Of the combined energy and materials total, 599 TJ has originated in renewable resources while 811 TJ comes from non-renewables. On the output side, materials are dominant and are mainly composed of goods from agriculture and related production and solid wastes that are all exported from the island. Taken together with the relatively large export of electricity produced by the wind turbines this means that work energies which must be characterized as renewable are dominating the outputs.

For a society to be designated as sustainable, the simple work energy balance (input WE less output WE) should be greater than or equal to zero, i.e. more work energy needs to be imported or formed within the society than is exported. In this case, the balance is clearly negative mainly for two reasons. One reason is the large import of work energy from solar radiation (nature not included). The other reason is that the products created by this import to a large extent are exported. At the same time the export of power from the renewable energy production contributes to the sustainability elsewhere, e.g. in the nearby societies. The work energy balance calculated as input less output may be calculated to $1410 - 1603 \text{ TJ} = - 193 \text{ TJ}$ per year.

The net surplus of 193 TJ per year is exported, which must be seen as a benefit to the rest of Denmark which gains the same 193 TJ per year in its overall balance, and, even better, as a gain in renewable energy. The island of Samsø at the same time loses this amount that could potentially be used to improve its own situation.

Four indicators have been suggested as measures or indicators of sustainability:

- 1) a structure indicator which tells how much infrastructure needs to be maintained and what the running costs are in terms of work energy. The indicator is calculated as the size of infrastructure divided by the imported work energy. In this case it is estimated to be $15560/1410$ which gives a ratio of 11. This means that an infrastructure is maintained which is 11 times larger than the import or in other words that the necessary import is 9% of the value of the infrastructure.
- 2) the ratio between renewable and non-renewable work energy (in this case is estimated to 599 TJ and 811 TJ, respectively). This constellation has a value of $599/811 = 0.73$ which means that renewable work energies are 73% of the non-renewable work energies used to drive the society.
- 3) the share of renewable work energy out of the total work energy imported to the island - in this case calculated to be $599/1410 = 0.43$ - meaning that 43% of the work energies driving the society are composed of renewable energy and matter flows.
- 4) an output/input indicator which according to the comments made above should be below or develop towards the value of 1 (one). In the case presented here the indicator is $1603/1410$ or 1.14, which is a result of the negative net balance of work energy on the island.

Calculating the amount of work energy which enters the island society an extra amount of 94 TJ per year needs to be considered. This amount stems from combustion of biomass which in this way of calculating the budget has been included in the material part. Thus the total work energy input sums up to 820 TJ per year and the part originating in

sustainable energy forms of energy is estimated to be 536 TJ per year. This means that 65% of the work energy cycling in the society is derived from sustainable resources.

4.9 Aiming at sustainability

As mentioned in the above the island of Samsø in 2011 presented a net surplus of energy production (electricity) from the wind turbines. The plan of the island and its inhabitants is now to be independent from fossil fuels in 2030 and it is also clear that a great potential for this process of conversion to a more sustainable society lies in the possibility of using the surplus. At the same time a new ferry which is planned to be more environmentally friendly – more energy efficient and running on a mix of electricity and biofuels - is expected to take over the route from Koldby Kås on Samsø to Kalundborg. This ferry is planned to use a new harbor under construction on the east coast. This will serve to reduce travel distance and fuel consumption even further.

Based on this information it is possible to establish a hypothetical scenario predicting the situation on the island around 2020. The assumptions made are the following:

- 1) a 5% increase in the production of sustainable electric energy from new wind turbines and solar thermal and photo-voltaic plants,
- 2) a conversion of heat and transport facilities so that all fossil fuel consumption from cars, oil-fired boilers and industry is replaced by electricity - with a subsequent reduction in electricity exports,
- 3) that the energy which today is used by the ferry to Zealand is replaced by electricity and bio-fuels produced on the island from various waste and organic products, and
- 4) during the same period the amount of infrastructure remains constant.

This situation may now be represented by the following figure (see next page). In Figure 1.9 it is seen that in 2020 one can expect to maintain the same infrastructure by a reduced input. At the same time the share of renewable inputs increases from 43% to 51%. Additionally a relatively smaller proportion of the work energy leaves the island. Altogether this means that the above measures - if undertaken - will contribute to bringing the island closer to a state of sustainability.

The gross work energy balance is still negative - 153 TJ per year although the balance has improved as compared to the situation in 2011. This is partly due to the contribution of increased internal use of electricity together with the use of organic based fuels for the restructuring of the fuel supply for the ferry transports.

The four indicators change as consequence of the development simulated by the scenario to:

- 1) the structure indicator develops to a factor of 12, meaning that the same amount of infrastructure is now maintained by an even lower import indicating an increase in sustainability. The necessary import to run the society is now only around 8% of the structure. It has become “cheaper” to retain the sustainability as it has a lower demand of supplied resources.
- 2) the ratio between renewable and non-renewable work energy is forecasted to develop to a level of $651/630 = 1.03$ which must be considered as a large improvement compared to the situation in 2011, because renewable resources now exceed the non-renewables.

Figure 1.9

A hypothetical accounting of the potential situation in 2020 provided that the measures described in the text are implemented - which basically includes an increased consumption of the energy from wind turbines to substitute the work energies in transports and heating (for details see text). The acronyms are as described in Fig. 1.8.

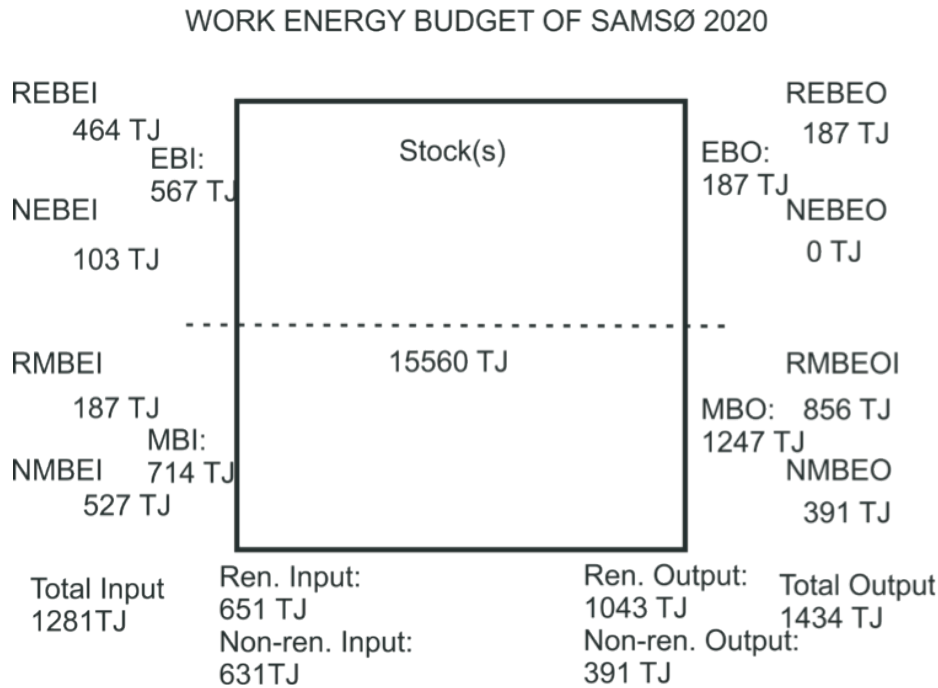

- 3) the share of renewable energy out of the total import can now be calculated to $651/1281 = 0.51$ which means that 51% of the work energies supplied to the island are from renewable energy and matter sources. Likewise, this is an improvement.
- 4) the output/import indicator has changed slightly to a value of 1.12. This trend also represents a development towards sustainability although the export of work energy is still larger than the imports.

A comparison of the indicators at present and after the possible implementation of measures are shown in the following table which clearly exhibit a change in the indicator values in accordance to what should be expected.

The net balance as well as the O/I-indicator is lowered as a consequence of the increase in internal use of the overhead in electricity from the wind turbines. The stock is increasing as it is assumed that the same stock is maintained for a lower input. The ratio between renewable, R to non-renewable resources, NR increases to a level above one as the use of renewable resources becomes dominant and corresponding to 51% of the overall consumption. The first of the two ratios is expected to be more sensitive at the beginning of a transition, whereas the latter will become more important at a later state where it should approach 1 (one).

An increase in imports of renewable work energy could for example be achieved by an increase in cultivation of catch crops in an amount corresponding

Table 1.1

Indicator	2011	2020
Energy balance	193	153
Stock Indicator	11	12
R/NR - ratio	0,73	1,03
Renewability fraction	0,43	0,51
O/I-indicator	1,14	1,12

The calculation of sustainability indicators for year the basis year 2011 compared to the year 2020 where some hypothetical change of the society has occurred upon the implementation of certain measures thought to improve sustainability of the island society (units TJ).

to 5000 tons carbon per year. This would lead to an extra import contribution to the work energy accounting of 180-190 TJ. This amount would be sufficient to make Samsø sustainable with respect to this indicator.

The work energy from renewable energy and matter flows in the scenario is estimated to be 598 TJ per year out of a total of 701 TJ per year which means that slightly more than 85% of the work energy entering the energy cycle of the island would come from renewable sources. It is considered achievable to replace the remaining 103 TJ per year in this work energy accounting by a supply of renewable-based work energy in order to achieve the final goal of being independent of fossil fuels in 2030.

Meanwhile it is also clear that there will continue to be a need for an inflow of materially bound work energies. Considering that these materials are predominantly composed of fossil fuel derivatives or find their origin in other non-renewable resources, this might well pose the greatest challenge to the island in the future.

5. Main conclusions and recommendations

A methodology has successfully been developed for establishing a masterplan for the elaboration of work energy accounting of societies. From this method of estimating the importance of societal activities it has been possible to establish a set of indicators which can serve to monitor our societies and subsequently can be used in decision making systems in order to select the most efficient measures which will make it possible to bring our societies closer and closer to a sustainable state. The approach is to a wide extent applicable to most European societies – spanning from municipalities, counties, regions and states - at least for smaller societies and where agriculture forms a major part of societal activities. Using this approach it is possible to identify the pools and track the flows of energy and matter in terms of work energy. As stated before, such an accounting system is considered to be useful in guiding societies towards a sustainable state. It serves to point out activities where large amounts of work energies are consumed. Such activities are obvious target areas for increased attention towards evaluation of possible measures which if implemented can serve to improve the work energy account and work energy efficiencies.

Some key figures for Samsø in 2011 can be found in the Table 1.2. It shows 1) the amounts of work energy imported to each sector, 2) work energies supplied from non-renewable resources, 3) the size of the sector in terms of work energy and 4) the resultant work energy which potentially can be exploited.

It is assumed that the methodology - due to the generalised perspective considered during the implementation - may also be up-scaled to larger societal systems, such as larger municipalities, regions or nations with relative ease. Only a certain amount of effort would be required in terms of searching for data sources and a wider adaptation of the approach.

At the same time during the development of the method special consideration was paid to the available data material and the regulations and directives issued by the European Union. This should at least permit the implementation of a sustainability analysis following the above principles within the European Union member states, since these have implemented the same regulations and directives.

Meanwhile, the societies of today – and their organizational arrangements in particular - are so complex and at the same time under continuous change, that it may well be that this permanent striving for variation could create barriers to an immediate use of data. In many cases the organization of data has been implemented with of other purposes in mind than the evaluation of sustainability.

Nevertheless, we consider that future work aiming at this type of sustainability analysis and evaluation will be facilitated by the framework laid out here and the amount of data acquired so far in connection with the project. The amount of data needed, in particular in the case of agriculture, has turned out to be so large that it is not possible to establish a simple tool for calculating sustainability on the present platform, i.e. by the spreadsheets behind the calculations presented, which have now reached a size which requires a potential user to possess a certain level of skills in spreadsheet techniques.

Table 1.2

Sector	Work Energy import	Import – non renewable	Work energy in infrastructure	Work Energy Produced/ - exported	Remarks
Energy	820	284	ne	316	infrastructure not estimated
Public	472	450*	9191	0	*estimated
Private HH	205	78	2187	22	only buildings in infrastructure
Crop prod.	137	88	1568	817	w/o solar contribution
Livestock prod.	376	ne	40	200	162 as natural fertilizer
Industry etc.	65	41	754	94	7 TJ as sludge
Nature	-	0	6562	0	terrestrial ecosystems

The table gives an overview of imports and exports of work energies for each sector together with the respective sizes of each of the six standard sectors used in this analysis (all values in TJ year-1, infrastructure TJ) – ne: – not estimated

A more simple solution for the future will be to organize the available data in one or more databases from which specific data can be extracted. A front end designed in web-page scripting languages would then guide potential users to select a sub-set of data necessary to calculate the state of sustainability of their society, to show indicators on a monitor or print out a report of essential data and results.

Carbon Cycling Samsø 2011 – CO₂ Emission and Carbon Balance

Introduction

Renewable energy now provides the major part of the energy used on the island of Samsø during the first decade of the 21st century and this leads to the key question: how much less carbon dioxide and methane are emitted on Samsø as a result of the introduction of renewable energy? Furthermore, we would like to know what we can do to reduce the carbon dioxide emission further.

When renewable energy is introduced to replace fossil fuel, a significant reduction of the carbon dioxide emission is expected, but this is not necessarily the case. To assess the carbon dioxide emission it is necessary to obtain knowledge about all the processes that involve carbon. Emission of a significant amount of carbon dioxide is the result of a number of natural processes for instance decomposition processes of organic matter in nature. Through photosynthesis nature also takes up a significant amount of carbon dioxide from the atmosphere.

Carbon model

Therefore, to find the resulting net emission of carbon dioxide and answer the above mentioned questions, we need to develop a carbon model for the focal area or region. Several carbon pools have transfers to other carbon pools and to keep track of all the processes that lead to the emission of carbon dioxide or other greenhouse gases, it is necessary to develop a carbon cycling model (CCM). The model should consider all the essential carbon pools and processes that imply transfers from one carbon pool to another, including of course all transfer processes which lead to the emission of carbon dioxide or other greenhouse gases. In total, 26 different carbon pools are considered in the CCM for Samsø, including the various agricultural products, three fractions of carbon in the soils, in forests, wetlands and grasslands, straw used for heating and for industrial production in the industry (Trolleborg).

Figure 2.1 shows a simplified conceptual diagram for the model, showing only the included compartments, pools or state variables (no controls indicated). It has only 16 state variables as “agro-production” here includes several products that are separate pools or state variables in the model.

The transfer processes among the various pools are quite well known from literature and the agricultural and industrial production on the island is known from available data. It is furthermore known how much forest, wetland and grassland, there is on Samsø, and how many inhabitants live on the island, how much solid waste they produce and how much carbon dioxide they respire.

Figure 2.1

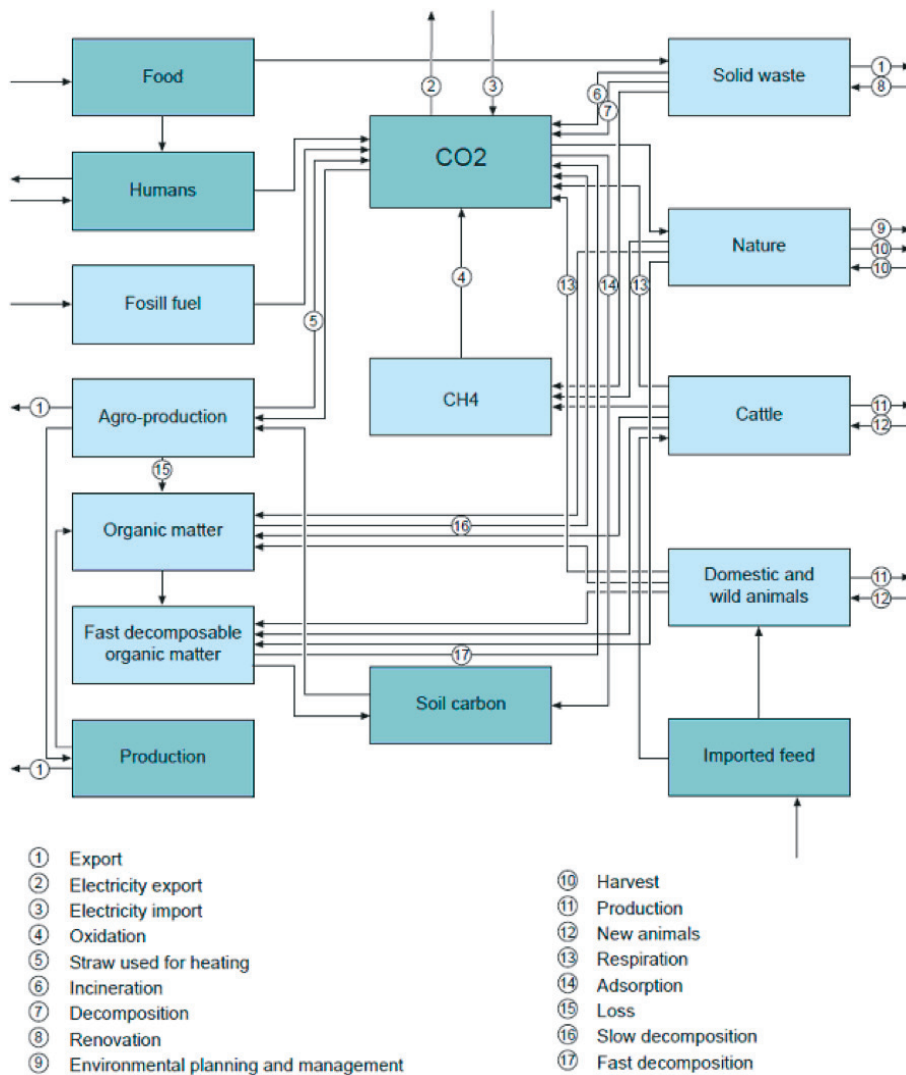

A simplified conceptual diagram of the model containing only 15 pools, while the model that was used has 26 pools, for instance a pool for each agro product, wheat, barley, etc.

Application of the model

The CCM has been developed on the basis of this knowledge and has furthermore been equipped to follow the annual variations. The model has been used to answer the first key question and a comparison of Figure 2.2 (the result of the model using the data from the year 2011) with Figure 2.3 (the result of the model applied by the use of the data from 1997, before the renewable energy project was launched) yields the answer.

Figure 2.3 presumes that the electricity produced today on the island by wind energy would in 1997 have been produced by a coal fired power plant with a reasonably high efficiency of 42%, but without recovery of waste heat. Waste heat recovery is common in Denmark today, but it was less common in 1997. Due to the use of renewable energy, it can be seen that Samsø today remove 26460 t carbon per year in form of carbon dioxide (97020 t per year of carbon dioxide is removed), while no carbon dioxide was removed in 1997. Figure 2.4 presents a complete carbon balance for the

continued on p. 30

Figure 2.2

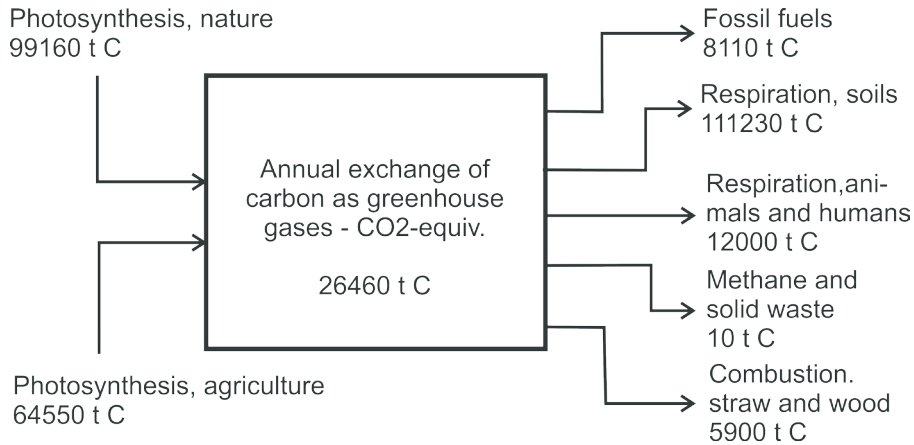

The result of the CCM. Samsø up takes up 26460 t C / year from the atmosphere: The processes leading to this result are summarized in the figure. The processes that produce carbon dioxide are: combustion of fossil fuel, combustion of straw and wood, respiration of humans and animals, methane, decomposition of solid waste and respiration of organic matter in soil, mainly by micro-organisms. The processes that take up carbon dioxide from the atmosphere are: photosynthesis on agricultural land and in the nature.

Figure 2.3

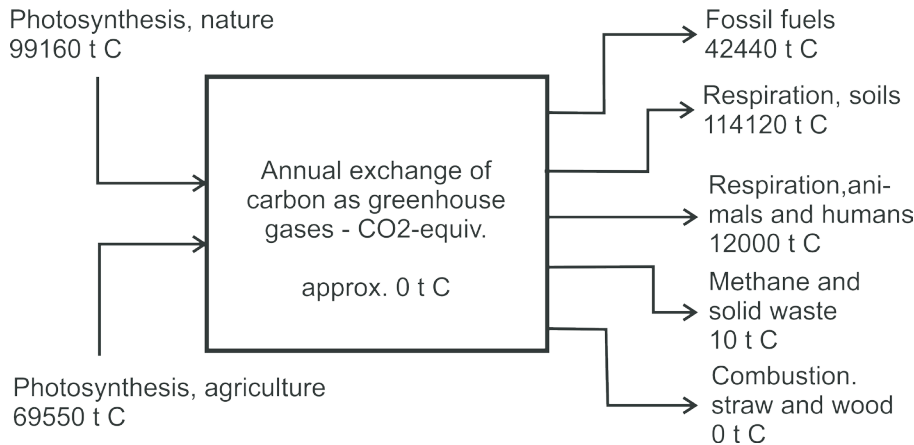

The results of the CCM before the Samsø Renewable Island Plan was launched. Today the island is removing more than 26 000 t carbon as carbon dioxide from the atmosphere. Before the plan was realized, the carbon dioxide produced from the electricity generated on the island changed the result to about 0 t C /year. Notice - that in 1997 straw and wood was not used, but returned to the soil, where it produced carbon dioxide.

Figure 2.4

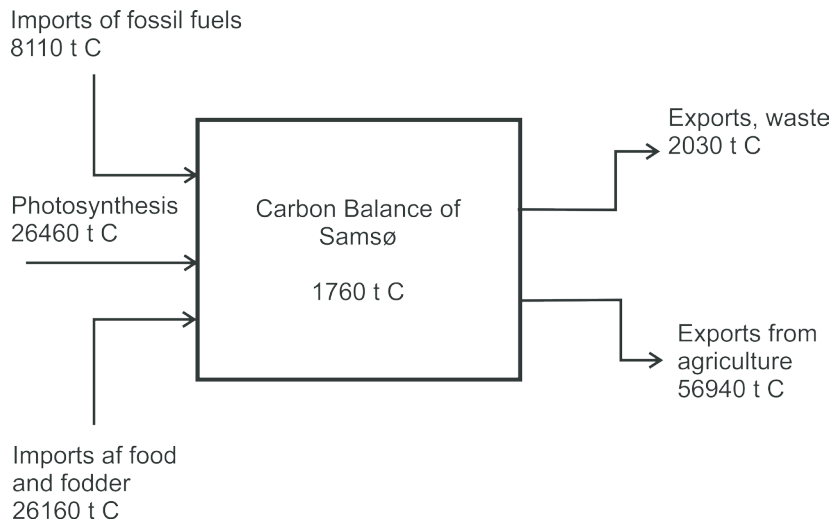

The export and import of carbon on the island of Samsø. The carbon pool on the island is almost in balance, as the difference between import and export is only about 3%. As the figure shows, there is an accumulation of carbon on Samsø of approx. 1760 tC / year.

Figure 2.5

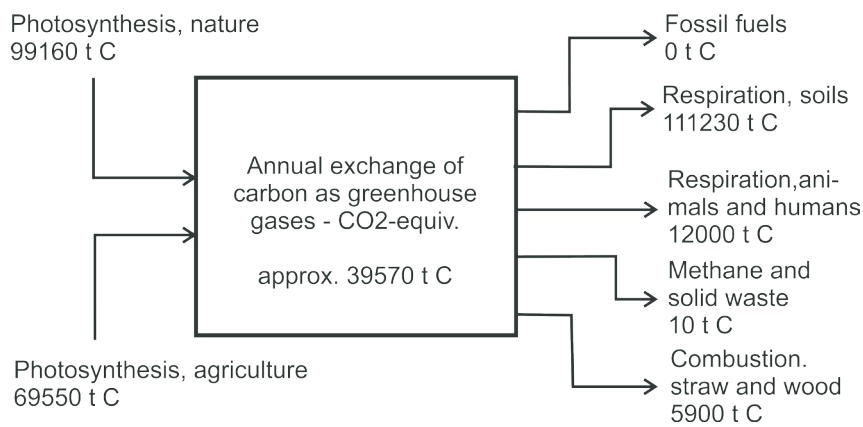

The results of the CCM after increasing the use of supplementary crops by 5000 t C /y and achieving a fossil fuel free island. The uptake is now almost 40000 t C /y which is about 13000 t C more than the results shown in Figure 2.2.

island today, showing a net accumulation of carbon on the island of 1764 t (this is only a small fraction of the carbon removed by photosynthesis in nature and in agriculture), while 56 940 t of carbon is exported in the form of agricultural products. This carbon will mostly be transferred to towns in Denmark, where it will be used as food and, subsequently emitted as carbon dioxide.

Carbon balance for Samsø

Figure 2.5 exemplifies the use of the model after further steps have been taken towards a higher uptake of carbon dioxide. The model is applied under the assumption that Samsø is fossil fuel free (which is planned to occur before year 2030) and that 5000 t of carbon are removed by the use of supplementary crops (catch crops) during the winter (for instance the use of grass on bare soil from about November to about March). If these two measures are taken, as much as almost 40000 t of carbon as carbon dioxide will be removed from the atmosphere. This amount corresponds also to the difference between carbon exported and imported, which means that Samsø in this scenario is in fact removing carbon from the atmosphere corresponding to the carbon dioxide emitted from towns when the agricultural production from Samsø is utilized elsewhere as food. A clear improvement of the carbon dioxide balance is therefore possible by the use of these two measures: make Samsø a fossil fuel free island and use supplementary (catch) crops.

The CCM can thus be used as a powerful management tool. If for instance production of biogas is introduced on the island, the CCM is able to answer the question: how much would the introduction of biogas change the carbon dioxide emission? The biogas can be produced on the basis of several different types of organic matter: pig or cow manure, industrial waste, garbage, straws and so on. The CCM can be used to determine the type of organic matter or rather the combination of organic matter, which would yield the lowest carbon dioxide emission.

It is the intention to use the CCM in the coming years to find the solutions for the development of the energy use on Samsø that yield the biggest reduction in emissions of carbon dioxide and other greenhouse gases.

Sensitivity analyses of the model show that the uncertainty of the input data causes an uncertainty in the output data of 10-15%. It means that Figure 2.5 tells us that the carbon removed from the atmosphere by Samsø is 34,000-46,000 t C per year and that the 2020 plans will imply an extra removal of 8,000-19,000 t C per year.

Samsø Energy Academy

Strandengen 1

DK - 8305 Samsø

Tel.: 8792 1011

E-mail: info@energiakademiet.dk

Web: www.energiakademiet.dk

