



**Aalborg Universitet**

**AALBORG UNIVERSITY**  
DENMARK

## **Optimal Power Flow in three-phase islanded microgrids with inverter interfaced units**

Sanseverino, Eleonora Riva; Quang, Ninh Nguyen; Di Silvestre, Maria Luisa; Guerrero, Josep M.; Li, Chendan

*Published in:*  
Electric Power Systems Research

*DOI (link to publication from Publisher):*  
[10.1016/j.epsr.2015.01.020](https://doi.org/10.1016/j.epsr.2015.01.020)

*Publication date:*  
2015

*Document Version*  
Early version, also known as pre-print

[Link to publication from Aalborg University](#)

*Citation for published version (APA):*  
Sanseverino, E. R., Quang, N. N., Di Silvestre, M. L., Guerrero, J. M., & Li, C. (2015). Optimal Power Flow in three-phase islanded microgrids with inverter interfaced units. *Electric Power Systems Research*, 123, 48-56.  
DOI: 10.1016/j.epsr.2015.01.020

### **General rights**

Copyright and moral rights for the publications made accessible in the public portal are retained by the authors and/or other copyright owners and it is a condition of accessing publications that users recognise and abide by the legal requirements associated with these rights.

- ? Users may download and print one copy of any publication from the public portal for the purpose of private study or research.
- ? You may not further distribute the material or use it for any profit-making activity or commercial gain
- ? You may freely distribute the URL identifying the publication in the public portal ?

### **Take down policy**

If you believe that this document breaches copyright please contact us at [vbn@aub.aau.dk](mailto:vbn@aub.aau.dk) providing details, and we will remove access to the work immediately and investigate your claim.

# Optimal Power Flow in three-phase islanded microgrids with inverter interfaced units

Eleonora Riva Sanseverino<sup>(1)\*</sup>, Ninh Nguyen Quang\*, Maria Luisa Di Silvestre\*, Josep M. Guerrero\*\*, Chendan Li\*\*

\*DEIM, Università di Palermo, Building 9, Viale delle Scienze 90128, Italy

\*\*Department of Energy Technology, Aalborg university Pontoppidanstraede 101, 9220 Aalborg East Denmark

(1) corresponding author: email [eleonora.rivasanseverino@unipa.it](mailto:eleonora.rivasanseverino@unipa.it); tel. 003909123860262; fax 0039091488452

**Abstract**— In this paper, the solution of the Optimal Power Flow (OPF) problem for three phase islanded microgrids is studied, the OPF being one of the core functions of the tertiary regulation level for an AC islanded microgrid with a hierarchical control architecture. The study also aims at evaluating the contextual adjustment of the droop parameters used for primary voltage and frequency regulation of inverter interfaced units. The work proposes a mathematical method for the OPF solution also considering the droop parameters as variables. The output of the OPF provides an iso-frequential operating point for all the generation units and a set of droop parameters for primary regulation. In this way, secondary regulation can be neglected in the considered hierarchical control structure. Finally, the application section provides the solution of the OPF problem over networks of different sizes and a stability analysis of the microgrid system using the optimized droop parameters, thus giving rise to the optimized management of the system with a new hierarchical control architecture.

**Keywords**— Optimal power flow, three phase systems, islanded operation, microgrids

## 1. Introduction

Optimal Power Flow, OPF, in electrical power systems is the problem of identifying the optimal dispatch of generation sources to get technical and economical issues. The problem is typically solved in Distribution Management Systems (DMS), which implement the highest level of the hierarchy of controllers within microgrids [1]. They take care of control functions such as optimized real and reactive

power dispatch, voltage regulation, contingency analysis, capability maximization, or reconfiguration. Microgrids, that are small low or medium voltage networks supplying interconnected loads by distributed energy resources, often show unbalanced loads and can work autonomously from the main grid. For this reason, a three phase OPF in islanded distribution systems is needed. The formulation of the problem should also account for the presence of inverter-interfaced units with control laws specifically designed to contrast voltage and frequency deviations when a sudden load variation occurs. Therefore the first issue to be analyzed is the efficient solution of the three phase Power Flow [2] in islanded three phase unbalanced systems; the formulation of the problem may also put into evidence the droop regulators parameters, so as to account for voltage and frequency deviations within admissible ranges.

In [3], a parametric study on these systems shows the dependency of power losses on the droop parameters, thus it makes sense to consider as part of the solution of the OPF also the set of droop parameters affecting the power injection from grid forming units. In the problem, the other variables are the power injections from PQ generation buses. Besides, according to traditional power flow solution method, a slack bus is needed; the latter is considered as an infinite bus capable of supplying or absorbing whatever real or reactive power flow thus keeping the system frequency and local bus voltage constant. This method for load flow solution is not suitable in islanded microgrids systems having small and comparable capacity generators. In these systems indeed, there is no generator that can be physically regarded as a slack bus. In order to face the problem above, in this paper it is proposed to model inverter interfaced generation units using the control law used for primary voltage and frequency regulation and a suitable power flow calculation method without a slack bus has been proposed in 2009 [2]. Differently from what is commonly done for loads, represented with a constant power model (P, Q), in this formulation, loads power depends on voltage and frequency. Constant power model may indeed lead to inconsistent and misleading results about loss reduction and other subsequent calculations on stability [5].

Authors in [2] devise a power flow calculation method for islanded power networks. However, the loads in the study only depend on voltage, not on frequency and the application is devoted to balanced transmission systems. Therefore the proposed model is not suitable for power flow calculations in microgrids, which typically show unbalanced loads. The power flow formulation in three phase unbalanced micro-grid with voltage and frequency dependent load modeling may bring misleading results with traditional methods, such as the Newton Raphson method, due to the presence of sparse matrices. A complete formulation of the problem here discussed can be found in [6], where a new method that can solve this problem called Newton Trust Region Method is proposed. The method is designed by a combination of Newton Raphson Method and Trust Region Method. The paper shows that this new method is a helpful tool to perform accurate steady state studies of islanded microgrids and the solution of a 25 bus test system is achieved

after a few iterations. However, the authors do not investigate the dependency between the droop parameters values and the power losses value for each loading condition and do not solve the OPF problem. The OPF in three phase unbalanced systems working in islanded conditions has been dealt with only recently, although some authors have investigated the influence of the network parameters over stability issues affecting the local controllers [4], showing that the selection of droop characteristics requires a thorough investigation of system steady-state and dynamic behavior.

More recently, in [7], the authors use Particle Swarm Optimization to choose the droop parameters and then perform the load flow analysis using the formulation seen in [2]. In the paper however the OPF is not dealt with the three phase load flow formulation. In [8], a methodology for unbalanced three-phase OPF for distribution management system in a smart grid is presented. However, the loads in the study do not depend on voltage and frequency and a traditional power flow solution method for grid connected systems is used.

In [9], it is shown that with P/V droop control, the DG units that are located electrically far from the load centers automatically deliver a lower share of the power. This automatic power-sharing modification can lead to decreased line losses; therefore, there the system shows an overall improved efficiency as compared to the methods focusing on perfect power sharing. Such concept of unequal power sharing is developed in this paper, where droops are optimized based on global objectives such as power losses, the latter being an optimization objective that seems concurrent with dynamic stability of the system.

In this paper, an original formulation and solution approach for the OPF problem in islanded distribution systems is proposed. The methodology is well suited for AC microgrids and can be envisioned as a new hierarchical control structure comprising only two levels: primary and tertiary regulation, the latter also providing iso-frequency operating points for all units and optimized droop parameters for primary regulation. The OPF provides a minimum losses operating point for which voltage drops are limited and power sharing is carried out according to the most adequate physical properties of the infrastructure thus giving rise to increased lifetime of lines and components. Due to the fact that the solution method is based on a numerical approach, the OPF is quite fast and efficient and the operating point can be calculated in times that are comparable to the current secondary regulation level times.

The paper is organized as follows. In section II, the modeling of the three-phase system for power flow solution is described. Then the power flow solution for unbalanced three phase microgrids systems using the Trust Region Method is described. Then, section III presents the OPF formulation for losses minimization in closed form. The formulation of the OPF in this first application is devoted to balanced load three phase system in which the only the P-f droop parameters can be optimized, while the Q-V droop parameters cannot. Section IV shows the attained results and a discussion on the attained results.

In the application sections, two test systems different scenarios have been investigated to show:

- the results of the OPFs solution and the results for a small 6 bus system along with the droop parameters attained;
- the results of stability studies carried out over the 6 bus system above.

## 2. Optimal Power flow in islanded AC microgrids

In order to provide a suitable formulation of the OPF problem in islanded AC microgrids also accounting for primary regulation issues, it is required a precise modeling of the system's lines and components.

### 2.1. Lines and loads modeling

Line modeling [6] in this study is based on the dependency on frequency of lines reactance. Carson's equations are used for a three phase grounded four wire system. With a grid that is well grounded, reactance between the neutral potentials and the ground is assumed to be zero. Applying the Kron's reduction [10] to the impedance matrix modeling the electromagnetic couplings between conductors and the ground, the following compact matrix formulation can be attained, please see figure 1 where superscript  $-n$  has been omitted:

$$[Z_{ij}^{abc}] = \begin{bmatrix} Z_{ij}^{aa} & Z_{ij}^{ab} & Z_{ij}^{ac} \\ Z_{ij}^{ba} & Z_{ij}^{bb} & Z_{ij}^{bc} \\ Z_{ij}^{ca} & Z_{ij}^{cb} & Z_{ij}^{cc} \end{bmatrix} \quad (1)$$

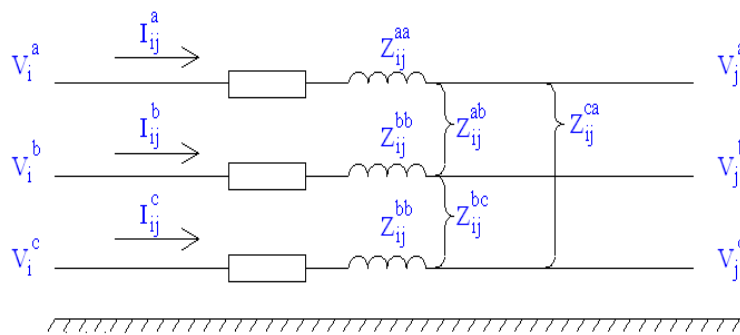

Figure 1 - Model of three phase line

### 2.2. Load modeling

The frequency and voltage dependency of the power supplied to the loads can be represented as follows:

$$P_{Li} = P_{0i}|V_i|^\alpha(1 + K_{pf}\Delta f) \quad (2)$$

$$Q_{Li} = Q_{0i}|V_i|^\beta(1 + K_{qf}\Delta f) \quad (3)$$

where  $P_{0i}$  and  $Q_{0i}$  are the rated real and reactive power at the operating points respectively;  $\alpha$  and  $\beta$  are the coefficients of real and reactive power. The values of  $\alpha$  and  $\beta$  are given in [11].  $\Delta f$  is the frequency deviation ( $f-f_0$ );  $K_{pf}$  takes the value from 0 to 3.0, and  $K_{qf}$  takes the value from -2.0 to 0 [12].

### 2.3. Distributed Generators modeling

The three phase real and reactive power generated from a DG unit with droop inverter interfaced generation can be expressed by the follow equations:

$$P_{Gri} = -K_{Gi}(f - f_{0i}) \quad (4)$$

$$Q_{Gri} = -K_{di}(|V_i| - V_{0i}) \quad (5)$$

In these equations, the coefficients  $K_{Gi}$  and  $K_{di}$  as well as  $V_{0i}$  and  $f_{0i}$  characterize the droop regulators of distributed generators. The three phase real and reactive power generated from a PQ\_generator can be expressed by the follow equations:

$$P_{PQi} = P_{PQispec} \quad (6)$$

$$Q_{PQi} = Q_{PQispec} \quad (7)$$

Where  $P_{PQispec}$  and  $Q_{PQispec}$  are the pre-specified active and reactive generated of the i-th PQ\_generator.

### 2.4. General formulation of three phase power flow problem

For each type of bus (such as PQ bus, PV bus or Droop-bus), we will have the different mismatch equations describing [6]. In this work, we assume that all buses are either droop-buses or PQ bus. For each PQ-Bus, we have mismatch quations as follow:

$$\begin{cases} P_{PQi,spec}^{a,b,c} = P_{Li}^{a,b,c}(f, |V_i^{a,b,c}|) \\ \quad + P_i^{a,b,c}(f, |V_i^{a,b,c}|, |V_j^{a,b,c}|, \delta_i^{a,b,c}, \delta_j^{a,b,c}) \end{cases} \quad (8)$$

$$\begin{cases} Q_{PQi,spec}^{a,b,c} = Q_{Li}^{a,b,c}(f, |V_i^{a,b,c}|) \\ \quad + Q_i^{a,b,c}(f, |V_i^{a,b,c}|, |V_j^{a,b,c}|, \delta_i^{a,b,c}, \delta_j^{a,b,c}) \end{cases} \quad (9)$$

where

$P_{PQi,spec}^{a,b,c}$  and  $Q_{PQi,spec}^{a,b,c}$  are the pre-specified active and reactive power at each phases of PQ-Bus i.

$V_i^{a,b,c}$  is the voltage of each phase at bus i

$\delta_i^{a,b,c}$  is the angle voltage of each phase at bus i

$P_{Li}^{a,b,c}$  and  $Q_{Li}^{a,b,c}$  are the active and reactive load power at each phases of bus i

$P_i^{a,b,c}$  and  $Q_i^{a,b,c}$  are the active and reactive power injected to the grid at each phases of bus i, can be attained, as follows:

$$P_i^a = \sum_{j=1}^{n_{br}} \sum_{ph=a,b,c} \begin{bmatrix} |V_i^a| |Y_{ij}^{a(ph)-n}| |V_i^{(ph)}| \cos(\theta_{ij}^{a(ph)} + \delta_i^{(ph)} - \delta_i^a) \\ -|V_i^a| |Y_{ij}^{a(ph)-n}| |V_j^{(ph)}| \cos(\theta_{ij}^{a(ph)} + \delta_j^{(ph)} - \delta_i^a) \end{bmatrix} \quad (10)$$

$$Q_i^a = \sum_{j=1}^{n_{br}} \sum_{ph=a,b,c} \begin{bmatrix} |V_i^a| |Y_{ij}^{a(ph)-n}| |V_j^{(ph)}| \sin(\theta_{ij}^{a(ph)} + \delta_i^{(ph)} - \delta_i^a) \\ -|V_i^a| |Y_{ij}^{a(ph)-n}| |V_i^{(ph)}| \sin(\theta_{ij}^{a(ph)} + \delta_i^{(ph)} - \delta_i^a) \end{bmatrix} \quad (11)$$

where  $Y_{ij}^{a(ph)-n}$  is the branch admittance between two nodes i and j

Similar equations can be extracted for phase b and phase c.

For each PQ-Bus i, we have the unknown variables:

$$x_{PQi} = [\delta_i^{a,b,c} |V_i^{a,b,c}|]^T \quad (12)$$

For all PQ-Bus, we have the unknown variables:

$$x_{PQ} = [x_{PQ1} \dots x_{PQn_{pq}}]^T \quad (13)$$

where  $n_{pq}$  is the number of PQ-Bus.

For each of the droop-buses, i, we have mismatch equations as follow:

$$\left\{ \begin{array}{l} 0 = P_{Li}^{a,b,c}(f, |V_i^{a,b,c}|) - P_{Gi}^{a,b,c} \\ \quad + P_i^{a,b,c}(f, |V_i^{a,b,c}|, |V_j^{a,b,c}|, \delta_i^{a,b,c}, \delta_j^{a,b,c}) \end{array} \right. \quad (14)$$

$$\left\{ \begin{array}{l} 0 = Q_{Li}^{a,b,c}(f, |V_i^{a,b,c}|) - Q_{Gi}^{a,b,c} \\ \quad + Q_i^{a,b,c}(f, |V_i^{a,b,c}|, |V_j^{a,b,c}|, \delta_i^{a,b,c}, \delta_j^{a,b,c}) \end{array} \right. \quad (15)$$

$$\left\{ \begin{array}{l} 0 = |V_i^a| - |V_i^b| \end{array} \right. \quad (16)$$

$$\left\{ \begin{array}{l} 0 = |V_i^a| - |V_i^c| \end{array} \right. \quad (17)$$

$$\left\{ \begin{array}{l} 0 = \delta_i^a - \delta_i^b - \left(\frac{2\pi}{3}\right) \end{array} \right. \quad (18)$$

$$\left\{ \begin{array}{l} 0 = \delta_i^a - \delta_i^b + \left(\frac{2\pi}{3}\right) \end{array} \right. \quad (19)$$

$$\left\{ \begin{array}{l} 0 = P_{Gi}^a + P_{Gi}^b + P_{Gi}^c - P_{Gi}(f) \end{array} \right. \quad (20)$$

$$\left\{ \begin{array}{l} 0 = Q_{Gi}^a + Q_{Gi}^b + Q_{Gi}^c - Q_{Gi}(|V_i^{a,b,c}|) \end{array} \right. \quad (21)$$

For each Droop-bus  $i$ , we have the unknown variables:

$$x_{Di} = [\delta_i^{a,b,c} |V_i^{a,b,c}| P_{Gi}^{a,b,c} Q_{Gi}^{a,b,c}]^T \quad (22)$$

For all Droop-bus, we have the unknown variables:

$$x_D = [x_{D1} \dots x_{Dn_d}]^T \quad (23)$$

where  $n_d$  is the number of Droop-bus.

So we have the total number of mismatch equations,  $n$ , and their corresponding unknown variables  $X$ :

$$n = 12 \times n_d + 6 \times n_{pq} \quad (24)$$

$$X = [x_D x_{pq} f] \quad (25)$$

The mismatch equations are nonlinear algebraic equations. The Trust region method is a robust method to solve such problems. Using the function “fsolve” of Matlab which uses the Trust region method, we can obtain the unbalanced three phase power flow solution.

Using the load flow problem formulation, parametric studies [3] on an islanded 25 bus test system, whose parameters are taken from [13], have been carried out. The load flow problem has been solved using the methodology proposed above. As expected, the results show that there are many different sets of parameters satisfying the condition  $f = 50\text{Hz}$ , while power losses change. Changing the droop parameters



produces a change of the power loss in the system. With  $f$  within the admissible range, the set of parameters satisfying the condition of minimum losses power sharing can thus be chosen.

### 3. Optimal Power Flow calculation

The Optimal Power Flow in this paper is carried out to minimize power losses. The solution algorithm is iterative and uses Lagrange method. The solution strategy has proved to be efficient for the definition of new operating points and new droop parameters for primary regulation; moreover, the proposed architecture integrating the proposed OPF may replace the secondary regulation level by finding an iso-frequency working condition for all units. It has indeed been shown, through parametric studies [3] that the power losses term is of course connected to the droop parameters values and thus such choice influences the steady state operation of microgrids.

Moreover sharing power among units so as to get a minimum loss operation will lead also to increased stability margins and probably a stable operation as proved in [14], [15].

The role of the OPF in the proposed controller architecture is depicted in figure 2 below and expressed by the following formula.

$$f = (f_{0i} + \Delta f) - (K_{Gi} + \Delta K_{Gi}) * (P_{Gri} - P_{0Gri}) \quad (26)$$

Where:  $f_{0i}$  and  $P_{0Gri}$  are the rated frequency and power of generator  $i$

$f$  and  $P_{Gri}$  are frequency and generated power of generator  $i$  at the new operating point

$\Delta f$  and  $\Delta K_{Gi}$  are frequency deviation and droop parameter to get the new operating point, respectively carried out by secondary and tertiary control. In this way, the OPF outputs a new operating point at a new frequency and also resets the different primary regulation parameters.

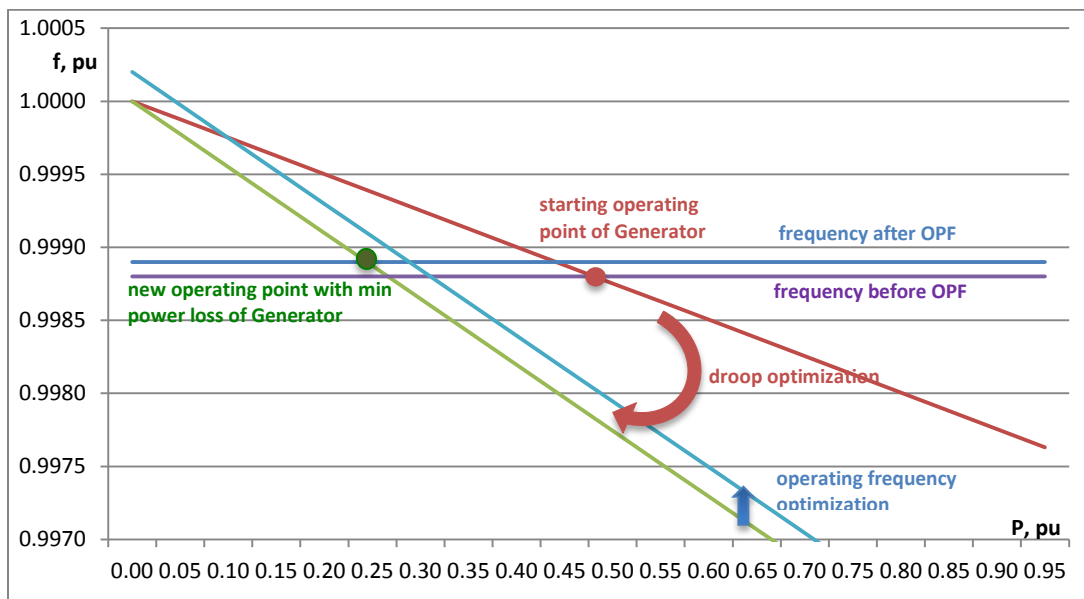

Figure 2 – Action of the OPF in the proposed controller architecture

A general formulation for the power losses equation, referred to as *Kron's loss formula*, is the following [16]:

$$P_{Loss} = \sum_{i=1}^{n_g} \sum_{j=1}^{n_g} P_{Gi} B_{ij} P_{Gj} + \sum_{i=1}^{n_g} B_{0i} P_{Gi} + B_{00} \quad (27)$$

where  $n_g$  is the number of generators (including of droop generators ( $n_{gr}$ ) and PQ generators ( $n_{PQ}$ )),  $P_{Gi}$  and  $P_{Gj}$  are matrix of generated real powers

$$P_{Gj} = \begin{bmatrix} P_{G1} \\ P_{G2} \\ \vdots \\ P_{Gng} \end{bmatrix}; \quad P_{Gi} = [P_{G1} \quad P_{G2} \quad \dots \quad P_{Gng}] \quad (28)$$

$B_{ij}$ ,  $B_{0i}$  and  $B_{00}$  are loss coefficients or B-coefficients.

Such formulation linearly relates the power losses with the generated powers, considering constant the system's frequency and bus voltages modules and displacements. Although the expression was originally written for transmission systems, it can also be used for microgrids, since it does not imply any assumption that is strictly valid for transmission. Besides, in the solution algorithm, the B-coefficients formulation for power losses is re-calculated at each iteration and this will be cleared out in later. The algorithm repeatedly calculates the system's electrical parameters (voltages modules, voltages displacements and frequency) through the solution of the power flow for new values of the generated power. Nonetheless, since the B-coefficient formulation is adequate for systems that have balanced loads, this hypothesis is a basic assumption to use the proposed method.

The three phase injected real and reactive power from a DG unit which is Droop\_bus are calculated in (3) and (4) and in this application, the reactive power depends on voltage but the relevant parameter ( $K_{di}$ ) can not be optimized.

The optimal dispatch problem is thus that to find the set of droop parameters ( $K_{Gi}$ ) and generating powers ( $P_{Gi}$ ) minimizing the power losses function expressed in (27), subject to the constraint that generation should equal total demands plus losses

$$\sum_{i=1}^{n_{gr}} P_{Gri} + \sum_{i=1}^{n_{PQ}} P_{PQi} = \sum_{i=1}^{n_d} P_{Li} + P_{Loss} \quad (29)$$

where  $P_{Gri}$  is the real power of droop\_generator  $i$ ;  $P_{PQi}$  is the real power of PQ\_generator  $i$ ;  $P_{Li}$  is the real power of load bus  $i$  and  $n_d$  is the number of load bus.

The problem should also meet the following inequality constraints, expressed as follows:

$$K_{Gimin} \leq K_{Gi} \leq K_{Gimax}, i = 1 \text{ to } n_{gr} \quad (30)$$

$$P_{PQimin} \leq P_{PQi} \leq P_{PQimax}, i = 1 \text{ to } n_{PQ} \quad (31)$$

$$|I_{mni}| \leq I_{mnimax} \quad (32)$$

where the  $K_{Gi}$  is a coefficient characterizing the droop regulator of droop\_bus generator  $i$ ,  $I_{mni}$  is the current on branch  $mn$  connecting buses  $m$  and  $n$ .

Equation (32) is the constraint about branches ampacity limit. However, due to the objective function formulation, it has been considered by verifying it at every cycle of the optimization algorithm thus producing a sub-optimal feasible solution. Figure 3 shows how the constraint is integrated into the optimization problem solution.

Following the Lagrange method, we obtain

$$\begin{aligned} L = & P_{Loss} + \lambda(\sum_{i=1}^{n_d} P_{Li} + P_{Loss} - \sum_{i=1}^{n_{gr}} P_{Gri} - \sum_{i=1}^{n_{PQ}} P_{PQi}) + \\ & \sum_{i=1}^{n_{gr}} \mu_{i(max)}(K_{Gi} - K_{Gi(max)}) + \sum_{i=1}^{n_{gr}} \mu_{i(min)}(K_{Gi} - K_{Gi(min)}) + \sum_{i=1}^{n_{PQ}} \gamma_{i(max)}(P_{PQi} - P_{PQimax}) + \\ & \sum_{i=1}^{n_{PQ}} \gamma_{i(min)}(P_{PQi} - P_{PQimin}) \quad (33) \end{aligned}$$

Where  $\lambda$ ,  $\mu_{i(max)}$ ,  $\mu_{i(min)}$ ,  $\gamma_{i(max)}$ ,  $\gamma_{i(min)}$  are the Lagrange multiplier and the  $\mu_{i(max)} = 0$ ,  $\gamma_{i(max)} = 0$  when  $K_{Gi} < K_{Gimax}$ ,  $P_{PQi} < P_{PQimax}$ ;  $\mu_{i(min)} = 0$ ,  $\gamma_{i(min)} = 0$  when  $K_{Gi} > K_{Gimin}$ ,  $P_{PQi} > P_{PQimin}$ . It means that if the constraint is violated, it will become active. To get the solution of the problem, we have to solve the set of equations include of the partials of the function below:

$$\frac{\partial L}{\partial K_{Gi}} = 0 \quad (34)$$

$$\frac{\partial L}{\partial P_{PQi}} = 0 \quad (35)$$

$$\frac{\partial L}{\partial \lambda} = 0 \quad (36)$$

$$\frac{\partial L}{\partial \mu_{max}} = K_{Gi} - K_{Gi(max)} = 0 \quad (37)$$

$$\frac{\partial L}{\partial \mu_{min}} = K_{Gi} - K_{Gi(min)} = 0 \quad (38)$$

$$\frac{\partial L}{\partial \gamma_{max}} = P_{PQi} - P_{PQi(max)} = 0 \quad (39)$$

$$\frac{\partial L}{\partial \gamma_{min}} = P_{PQi} - P_{PQi(min)} = 0 \quad (40)$$

Equations (37), (38), (39) and (40) mean that when  $K_{Gi}$  and  $P_{PQi}$  are within their limits, we will have:

$$\mu_{i(min)} = \mu_{i(max)} = 0 \quad (41)$$

and

$$\gamma_{i(min)} = \gamma_{i(max)} = 0 \quad (42)$$

First condition, given by (34) results in

$$\frac{\partial L}{\partial K_{Gi}} = \frac{\partial P_{Loss}}{\partial K_{Gi}} + \lambda \left( \frac{\partial \sum_{i=1}^{n_d} P_{Li}}{\partial K_{Gi}} + \frac{\partial P_{Loss}}{\partial K_{Gi}} - \frac{\partial \sum_{i=1}^{n_{gr}} P_{Gri}}{\partial K_{Gi}} - \frac{\partial \sum_{i=1}^{n_{PQ}} P_{PQi}}{\partial K_{Gi}} \right) = 0 \quad (43)$$

Since

$$\frac{\partial \sum_{i=1}^{n_{gr}} P_{Gri}}{\partial K_{Gi}} = \frac{dP_{Gri}}{dK_{Gi}} = -(f - f_{0i}) \quad (44)$$

$$\frac{\partial \sum_{i=1}^{n_{PQ}} P_{PQi}}{\partial K_{Gi}} = 0 \quad (45)$$

$$\frac{\partial \sum_{i=1}^{n_d} P_{Li}}{\partial K_{Gi}} = \frac{dP_{Li}}{dK_{Gi}} = 0 \quad (46)$$

And therefore the condition for optimum dispatch becomes

$$\frac{\partial P_{Loss}}{\partial K_{Gi}} (\lambda + 1) + \lambda (f - f_{0i}) = 0 \quad (47)$$

Since

$$\frac{\partial P_{Loss}}{\partial K_{Gi}} = (f - f_{0i}) \left( -2 \sum_{j=1}^{n_g} B_{ij} P_{Gj} - B_{0i} \right) \quad (48)$$

substituting in (47) we have

$$\left\{2 \sum_{j=1}^{n_g} B_{ij} P_{Gj} + B_{0i}\right\} (\lambda + 1) - \lambda = 0 \quad (49)$$

or

$$B_{ii}(f - f_{oi})K_{Gi} - \sum_{\substack{j=1 \\ j \neq i}}^{n_g} B_{ij} P_{Gj} = \frac{B_{0i}}{2} - \frac{\lambda}{2(\lambda+1)} \quad (50)$$

Second condition, given by (35) results in

$$\frac{\partial L}{\partial P_{PQi}} = \frac{\partial P_{Loss}}{\partial P_{PQi}} + \lambda \left( \frac{\partial \sum_{i=1}^{n_d} P_{Li}}{\partial P_{PQi}} + \frac{\partial P_{Loss}}{\partial P_{PQi}} - \frac{\partial \sum_{i=1}^{n_{gr}} P_{Gri}}{\partial P_{PQi}} - \frac{\partial \sum_{i=1}^{n_{PQ}} P_{PQi}}{\partial P_{PQi}} \right) = 0 \quad (51)$$

Since

$$\frac{\partial \sum_{i=1}^{n_{gr}} P_{Gri}}{\partial P_{PQi}} = 0 \quad (52)$$

$$\frac{\partial \sum_{i=1}^{n_{PQ}} P_{PQi}}{\partial P_{PQi}} = 1 \quad (53)$$

$$\frac{\partial \sum_{i=1}^{n_d} P_{Li}}{\partial P_{PQi}} = \frac{dP_{Li}}{dP_{PQi}} = 0 \quad (54)$$

And therefore the condition for optimum dispatch becomes

$$\frac{\partial P_{Loss}}{\partial P_{PQi}} (\lambda + 1) - \lambda = 0 \quad (55)$$

Since

$$\frac{\partial P_{Loss}}{\partial P_{PQi}} = 2 \sum_{j=1}^{n_g} B_{ij} P_{Gj} + B_{0i} \quad (56)$$

substituting in (49) we have

$$\left\{2 \sum_{j=1}^{n_g} B_{ij} P_{Gj} + B_{0i}\right\} (\lambda + 1) - \lambda = 0 \quad (57)$$

or

$$B_{ii}P_{PQi} + \sum_{\substack{j=1 \\ j \neq i}}^{ng} B_{ij}P_{Gj} = \frac{\lambda}{2(\lambda+1)} - \frac{B_{oi}}{2} \quad (58)$$

Third condition, given by (36) results in

$$\sum_{i=1}^{nd} P_{Li} + P_{Loss} - \sum_{i=1}^{ngr} P_{Gri} - \sum_{i=1}^{nPQ} P_{PQi} = 0 \quad (59)$$

Expressing (50) and (58) in form of matrix, we have

$$\begin{bmatrix} B_{11} & B_{12} & \dots & B_{1ng} \\ B_{21} & B_{22} & \dots & B_{2ng} \\ \vdots & \vdots & \ddots & \vdots \\ B_{ng1} & B_{ng2} & \dots & B_{ngng} \end{bmatrix} \begin{bmatrix} K_{G1}(f - f_{01}) \\ K_{G2}(f - f_{02}) \\ \vdots \\ -P_{PQ1} \\ \vdots \\ K_{Gng}(f - f_{0ng}) \end{bmatrix} = \frac{1}{2} \begin{bmatrix} B_{01} - \frac{\lambda}{\lambda+1} \\ B_{02} - \frac{\lambda}{\lambda+1} \\ \vdots \\ B_{0ng} - \frac{\lambda}{\lambda+1} \end{bmatrix} \quad (60)$$

We use the gradient method to solve this set of equation in (60). First, we estimated an initial value of  $\lambda^{(k)}$ , then we can solve the set of linear equations. From (60), formulation to calculate  $K_{Gi}$  at the  $k_{th}$  iteration can be extracted as

$$K_{Gi}^{(k)} = \frac{B_{oi}(\lambda^{(k)+1}) - \lambda^{(k)} - 2(\lambda^{(k)+1}) \sum_{\substack{j=1 \\ j \neq i}}^{ng} B_{ij}K_{Gj}^{(k)}(f - f_{0j})}{2(\lambda^{(k)+1})B_{ii}(f - f_{0i})} \quad (61)$$

From (60), formulation to calculate  $P_{PQi}$  at the  $k_{th}$  iteration can be extracted as

$$P_{PQi}^{(k)} = \frac{-B_{oi}(\lambda^{(k)+1}) + \lambda^{(k)} - 2(\lambda^{(k)+1}) \sum_{\substack{j=1 \\ j \neq i}}^{ng} B_{ij}P_{Gj}^{(k)}}{2(\lambda^{(k)+1})B_{ii}} \quad (62)$$

Substituting for  $K_{Gi}$  from (61) in (5) to get  $P_{Gri}$  and then substituting  $P_{PQi}$  from (62) and  $P_{Gri}$  in (59) we have

$$-\sum_{i=1}^{ngr} \frac{B_{oi}(\lambda^{(k)+1}) - \lambda^{(k)} - 2(\lambda^{(k)+1}) \sum_{\substack{j=1 \\ j \neq i}}^{ng} B_{ij}K_{Gj}^{(k)}(f - f_{0j})}{2(\lambda^{(k)+1})B_{ii}} + \sum_{i=1}^{nPQ} \frac{-B_{oi}(\lambda^{(k)+1}) + \lambda^{(k)} - 2(\lambda^{(k)+1}) \sum_{\substack{j=1 \\ j \neq i}}^{ng} B_{ij}P_{Gj}^{(k)}}{2(\lambda^{(k)+1})B_{ii}} = \sum_{i=1}^{nd} P_{Li} + P_{Loss}^{(k)} \quad (63)$$

or

$$\sum_{i=1}^{ng} \frac{-B_{oi}(\lambda^{(k)+1}) + \lambda^{(k)} - 2(\lambda^{(k)+1}) \sum_{j=1}^{ng} B_{ij} P_{Gj}^{(k)}}{2(\lambda^{(k)+1}) B_{ii}} = \sum_{i=1}^{nd} P_{Li} + P_{Loss}^{(k)} \quad (64)$$

or

$$g(\lambda^{(k)}) = \sum_{i=1}^{nd} P_{Li} + P_{Loss}^{(k)} \quad (65)$$

Expanding  $g(\lambda^{(k)})$  in Taylor's series about an operating point  $\lambda^{(k)}$ , and neglecting the higher-order terms we get

$$g(\lambda^{(k)}) + \left(\frac{dg(\lambda)}{d\lambda}\right)^{(k)} \Delta\lambda^{(k)} = \sum_{i=1}^{nd} P_{Li} + P_{Loss}^{(k)} \quad (66)$$

or

$$\Delta\lambda^{(k)} = \frac{\sum_{i=1}^{nd} P_{Li} + P_{Loss}^{(k)} - g(\lambda^{(k)})}{\left(\frac{dg(\lambda)}{d\lambda}\right)^{(k)}} = \frac{\Delta P^{(k)}}{\Sigma\left(\frac{dP_i}{d\lambda}\right)^{(k)}} \quad (67)$$

where

$$\sum_{i=1}^{ng} \left(\frac{dP_i}{d\lambda}\right)^{(k)} = \sum_{i=1}^{ng} \frac{1}{2(\lambda^{(k)+1})^2 B_{ii}} \quad (68)$$

and therefore

$$\lambda^{(k+1)} = \lambda^{(k)} + \Delta\lambda^{(k)} \quad (69)$$

The flowchart of the algorithm is shown in figure 3.

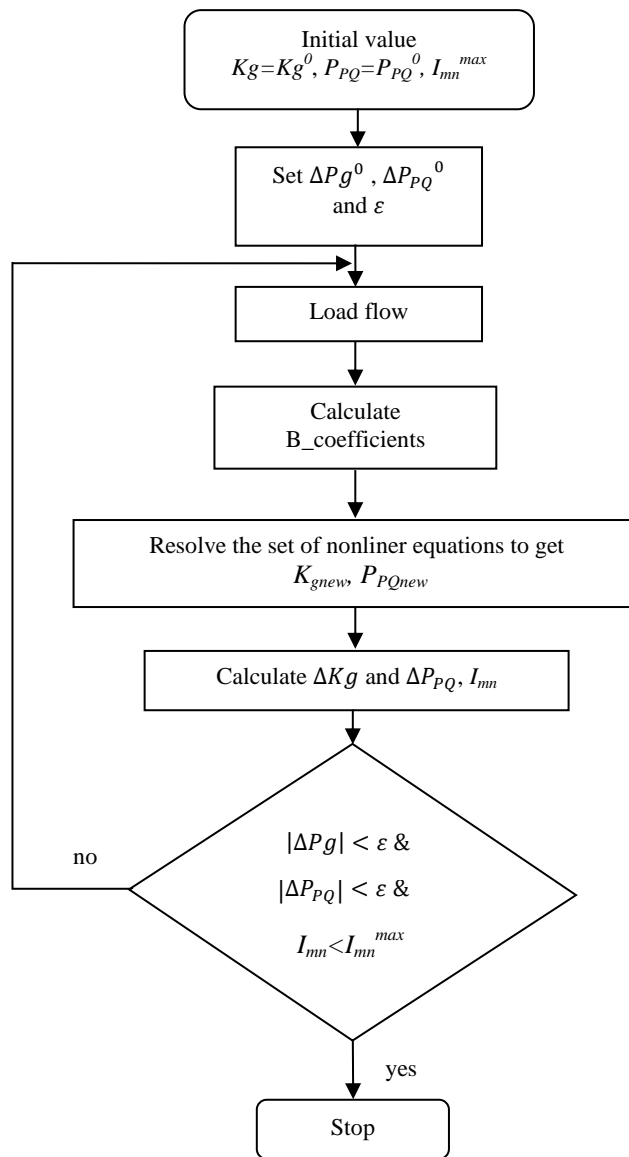

Figure 3 - Flowchart of the algorithm

#### 4. Test Results

In this section, the OPF algorithm has been applied to a 6 bus test system represented in figure 4, for the loading condition reported in Table I of Appendix B. Then the dynamic behavior of the system has been tested to check the stability of the attained operating point and relevant droop operation parameters. The electrical data of the test system are similar to [6], they are shown in Tables I-III of Appendix B;  $S_B = 10000\text{kVA}$ ,  $V_B = 230\text{V}$ ,  $f = 60\text{Hz}$ ,  $K_{pf} = K_{qf} = 0$  (in eqns. (3) and (4). Table I shows the results attained after some iterations of the OPF algorithm applied for the considered 6 bus system.

In the same Table, in bold the optimal power flow solution and the relevant droop parameters are reported.



As it can be observed, for the considered loading condition, a reduction of 14.04% of power losses is attained. Results of the same OPF procedure carried out for other loading conditions on the same test system that can be experienced realistically (changing the load factor between 0.5 p.u. and 1 p.u.) still show a power losses reduction that does not go below 8% in all cases.

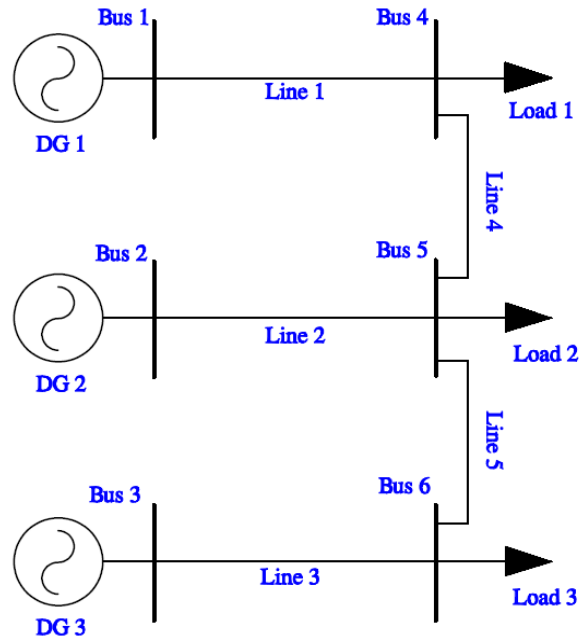

Figure 4 - The 6 bus test system

#### 4.1. Stability issues and architecture of the control system

The dynamic behavior of the system with optimized parameters has been tested for a step load change. At  $t = 10s$ , a three phase resistor branch ( $12\Omega$  in each phase) and three phase inductor branch ( $0.01H$  in each phase) is added to bus 4 and bus 6 by paralleling respectively.

The simulations, Figures 5 and 6 show that the droop parameters found after the OPF application produce stable results. As it was expected, the power sharing condition proposed by the OPF solution increases the output power from the units (DG1 and DG3) that are electrically closer to the loads that have increased their absorption and decreases the contribution from the electrically farthest unit (DG2). Moreover the contextual variation of droop gains in the same direction (increase for those that are closer and decrease for the farthest) implies and even more reactive response if loads will keep varying in the same direction).

Stable behavior was expected since in [15] the stability margins are improved when: loading is shared according to lines capacity and frequency is higher (consequence of lower power losses in islanded systems). What cannot be ensured is of course that power is shared according to DG units capacity.

To see what happens with the system stability between one OPF execution and the other, the following experiment has been carried out. First the load at bus 4 was increased by 50%, the OPF was run and the optimized parameters for the current loading condition were calculated. Then the load was strongly changed in the opposite direction (decrease the load by 50% at both bus 4 and bus 6) to check the stability of the system. The results shown in Figures 7 and 8 show that the system is still stable.

The application carried out even if for a simplified case (balanced loads) where only the P-f droop parameters can be optimized shows the possibility to carry out a centralized and optimized control of the system even when the grid is islanded. The load flow method, proposed in the first part of the paper, for unbalanced systems can indeed be easily integrated into a heuristic-based OPF giving rise to solution parameters both for P-f droop generation units and for Q-V droop generation units.

The proposed OPF algorithm to be integrated into a centralized controller of a microgrid would produce reduced losses and voltage drops all over the system. Moreover, if carried out frequently, i.e. every few minutes, it eliminates the need for a distributed secondary regulation, since it produces isofrequential, and within admissible rated bounds, operating points for all droop interfaced generators.

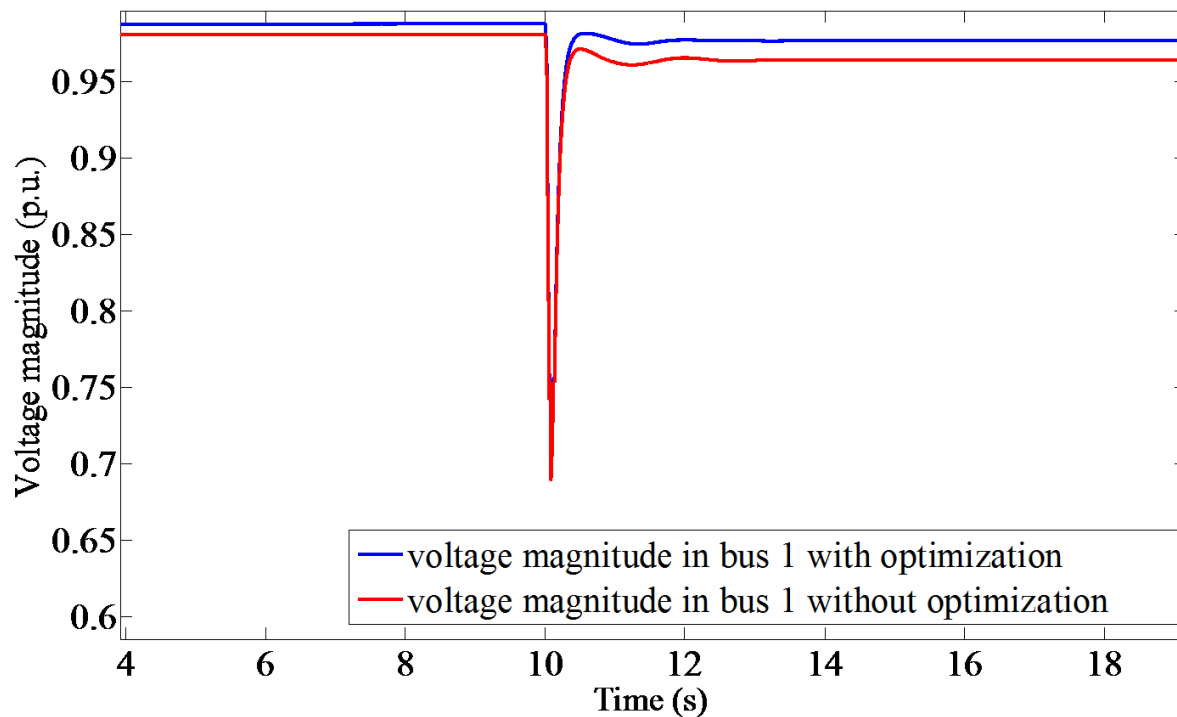

Figure 5 - Comparison of voltage magnitude response in bus1 before and after the optimization

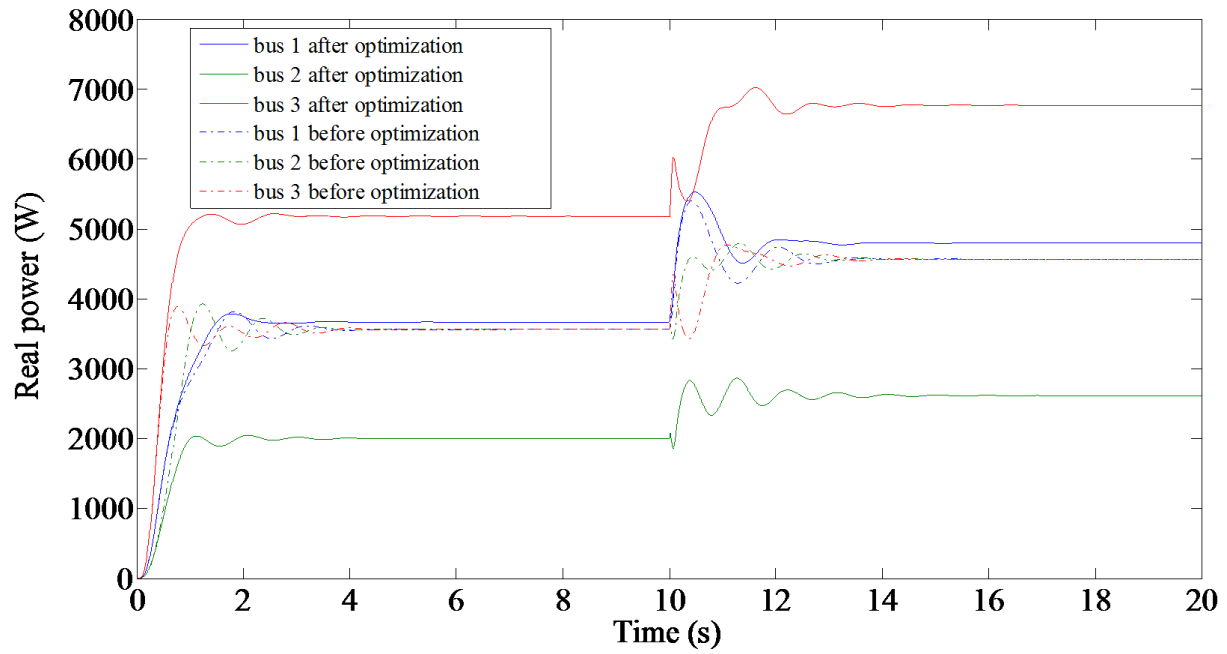

Figure 6 - Comparison of power magnitude response in bus 1, 2, 3 before and after the optimization

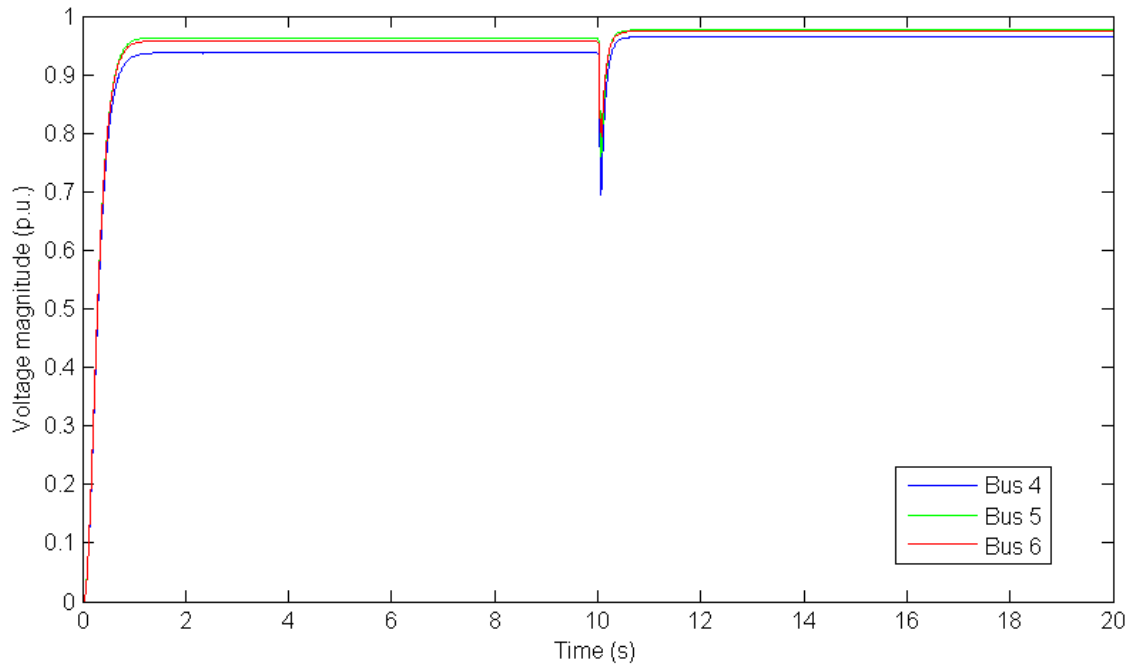

Figure 7 - Comparison of voltage magnitude response in bus1 before and after decreasing the load

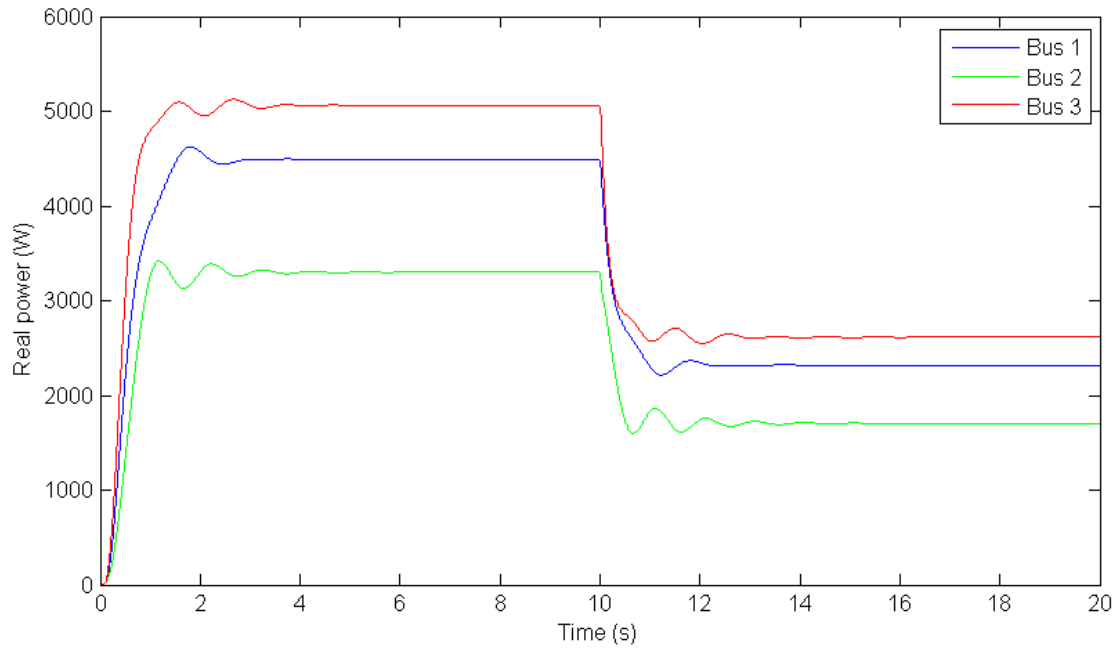

Figure 8 - Comparison of power magnitude response in bus 1, 2, 3 before and after decreasing the load

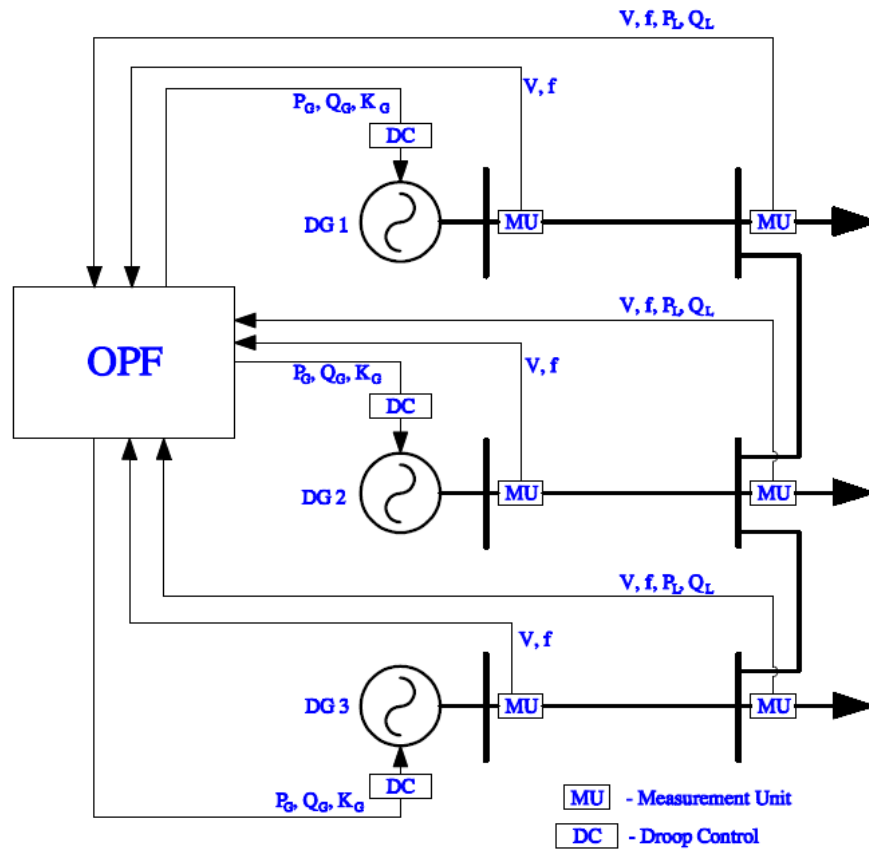

Figure 9 – General architecture of the control system

The general architecture of the control system is therefore depicted in figure 9.

After a load variation and after the primary regulation, in order to compensate for the frequency and amplitude deviations, the OPF is started. The frequency and voltage amplitude levels in the microgrids  $f$  and  $V$  at all buses are sensed and compared with the references  $f^*_{MG}$  and  $V^*_{MG}$ , if the errors are greater than a given threshold (which takes into account the admissible frequency and voltage deviations), then the OPF is started again in order to restore the operating voltage and frequency.

Table I - Result of optimal load flow on 6 bus system

N0. Iteration	Load flow, pu				Optimization, pu		
	Number	$P_{Gi}$	$K_G$	Ploss	$P_{G_{new}}$	$K_{G_{new}}$	Lambda
1	1(Droop)	0.3916	401.0638	0.0265391	0.3978	407.375	0.046917
	2(Droop)	0.3916	401.0638		0.3016	308.8672	
	3(Droop)	0.3916	401.0638		0.4747	486.2074	
2	1(Droop)	0.3978	407.3750	0.0241074	0.3968	406.3396	0.043823
	2(Droop)	0.3016	308.8672		0.2165	221.7403	
	3(Droop)	0.4748	486.2074		0.5599	573.4366	
3	1(Droop)	0.3972	<b>406.3396</b>	<b>0.0228142</b>			
	2(Droop)	0.2167	<b>221.7403</b>				
	3(Droop)	0.5605	<b>573.4366</b>				

## 5. Conclusions

In this paper, a new OPF algorithm for islanded microgrids is proposed. The algorithm produces a minimum losses and stable operating point with relevant droop parameters and solves the OPF problem in closed form. It is interesting to point out that the underlying idea of a centralized controller providing operating points at the same frequency and within admissible bounds may lead to a simplified hierarchical structure only including two control levels (primary and tertiary control levels). Nevertheless, at the moment the proposed algorithm cannot deal with unbalanced loads and only outputs results for the P-f droops parameters, letting the Q-V droops parameters non optimized.

The algorithm as it is proposed in the papers is feasible for small systems where centralized operation is possible and loads are typically balanced.

Further research will be oriented towards the implementation of the similar approaches for unbalanced distribution systems, since the conclusions that have been drawn can be generalized. Moreover, further investigations will concern the implementation of the simplified hierarchical control architecture with only primary and tertiary regulation. Another interesting conclusion concerns the fact that minimum losses

operation gives rise to stable operating points at same frequency with the relevant droop parameters for inverter interfaced units.

## Appendix B

Table B.1 - Bus Data of 6 bus test system

Bus number	Type generator	Load, per-phase		Generator				Exponent of Loads	
		R, Ohm	L, mH	K <sub>di</sub>	V <sub>G0i</sub> , V	K <sub>Gi</sub>	2* $\pi$ *f <sub>0i</sub> , rad/s	Alpha	Beta
1	Droop	0.0000	0.0000	17.69231	230.00	401.0638	377.00	0	0
2	Droop	0.0000	0.0000	17.69231	230.00	401.0638	377.00	0	0
3	Droop	0.0000	0.0000	17.69231	230.00	401.0638	377.00	0	0
4	0	6.9500	12.2000	0.00	0.00	0.00	377.00	2.00	2.00
5	0	0.0000	0.0000	0.00	0.00	0.00	377.00	2.00	2.00
6	0	5.0140	9.4000	0.00	0.00	0.00	377.00	2.00	2.00

Table B.2 - Line Data of 6 bus test system

Bus nl	Bus nr	R, Ohm	L, H
1	4	0.3	0.00035
2	5	0.2	0.00025
3	6	0.05	0.00005
4	5	0.43	0.000318
5	6	0.15	0.001843

Table B.3 - Limit of K<sub>G</sub> on 6 bus system

N0. Generator	Type Generator	Min K <sub>G</sub> , pu	Max K <sub>G</sub> , pu
1	Droop	100.00	750.00
2	Droop	100.00	750.00
3	Droop	100.00	750.00

## References

- [1] J. M. Guerrero, J. C. Vásquez, J. Matas, L. G. de Vicuña, M. Castilla, “Hierarchical Control of Droop-Controlled AC and DC Microgrids—A General Approach Towards Standardization”, 2011, IEEE Trans on Industrial electronics, vol.58, issue 1 pp.158-172.
- [2] S. Yan, S. Nai, and Y. Zhi, “Power Flow Calculation Method for Islanded Power Network”, Proceedings of Asia Pacific Power and Energy Engineering Conference, APPEEC 2009, 27-31 March 2009, pp.1-5.
- [3] E. Riva Sanseverino, N. N. Quang, G. Zizzo, M. L. Di Silvestre, J. M. Guerrero “A parametric study on unbalanced three phase islanded microgrids with inverter interfaced units”, AEIT Annual Conference, Mondello, Italia. IEEE conference publications, 2013
- [4] S. Tabatabaee, H. R. Karshenas, A. Bakhshai, P. Jain, “Investigation of Droop Characteristics and X/R ratio on Small-Signal Stability of Autonomous Microgrid”, 2011 2nd Power electronics, drive systems and technologies conference.
- [5] S. Devender, R. K. Misra, and S. Deependra, “Effect of Load Models in Distributed Generation Planning”, IEEE Transactions on Power system, Vol. 22, no. 4, November, 2007.
- [6] M. Mora, E. Hany, F.Ehab, and A. Yasser, “A Novel and Generalized Three-Phase Power Flow Algorithm for Islanded Microgrids Using a Newton Trust Region Method”, IEEE Transactions on Power system, Vol. 28, no. 1, February, 2013.
- [7] A. Elrayyah, Y. Sozer, M. Elbuluk, “A Novel Load Flow Analysis for Particle-Swarm Optimized Microgrid Power Sharing” Proc. of the IEEE APEC Lon Beach CA, 2013.
- [8] S. Bruno S., L. Silvia, R. Giuseppe, S. Ugo and M. La Scala “Unbalanced Three-Phase Optimal Power Flow for Smart Grids”, IEEE Transactions on Industrial Electronics, VOL. 58, NO. 10, OCTOBER 2011.
- [9] T.L. Vandoorn, J.D.M. De Kooning, B. Meersman, J.M. Guerrero, and L. Vandeveldde, “Automatic Power-Sharing Modification of P/V Droop Controllers in Low-Voltage Resistive Microgrids” IEEE Transactions on Power Delivery, Vol. 27, n. 4, Oct. 2012
- [10] W. H. Kersting, “Series impedance of overhead and underground lines”, in Distribution System Modeling and Analysis. Boca Raton, FL: CRC, 2002, ch. \$, pp. 77-108.
- [11] IEEE Task Force on Load Representation for Dynamic Performance “Bibliography on load models for power flow and dynamic performance simulation”, IEEE Transactions on Power systems, vol. 10, no. 1, pp 523-538, Feb. 1995

- [12] P. Kundur, "Power system loads", in *Power System Stability and Control*. New York: McGraw-Hill, 1994, ch. 7, pp. 271-314.
- [13] G. K. V. Raju and P. R. Bijwe, "Efficient reconfiguration of balanced and unbalanced distribution systems for loss minimisation", *IET Gen., Transm., Distrib.*, vol.2, no. 1, pp 7-12, Jan. 2008.
- [14] Y. Li and Y. Li, "Decoupled power control for an inverter based low voltage microgrid in autonomous operation", in *Conf. Rec. IEEE International Power Electronics and Motion Control Conference (IPEMC'09)*, Wuhan China, pp. 2490-2496, 2009.
- [15] E. Barklund, Nagaraju Pogaku, Milan Prodanovic', C. Hernandez-Aramburo, Member, IEEE, and Tim C. Green, "Energy Management in Autonomous Microgrid Using Stability-Constrained Droop Control of Inverters", in *IEEE TRANSACTIONS ON POWER ELECTRONICS, VOL. 23, NO. 5, SEPTEMBER 2008*.
- [16] H. Saadat, "Derivation of Loss Formula", in *Power systems analysis*. Singapore: McGraw-Hill, 1999, ch. 7, pp. 289-295.