



Aalborg Universitet

AALBORG UNIVERSITY  
DENMARK

## Multi-Objective Control of Balancing Systems for Li-Ion Battery Packs

Barreras, Jorge Varela; Pinto, Claudio; de Castro, Ricardo; Schaltz, Erik; Andreasen, Søren Juhl; Araujo, Rui Esteves

*Published in:*

Proceedings of the 2014 IEEE Vehicle Power and Propulsion Conference (VPPC)

*DOI (link to publication from Publisher):*

[10.1109/VPPC.2014.7007107](https://doi.org/10.1109/VPPC.2014.7007107)

*Publication date:*

2014

*Document Version*

Peer reviewed version

[Link to publication from Aalborg University](#)

*Citation for published version (APA):*

Barreras, J. V., Pinto, C., de Castro, R., Schaltz, E., Andreasen, S. J., & Araujo, R. E. (2014). Multi-Objective Control of Balancing Systems for Li-Ion Battery Packs: A paradigm shift? In Proceedings of the 2014 IEEE Vehicle Power and Propulsion Conference (VPPC) Coimbra: IEEE Press. DOI: 10.1109/VPPC.2014.7007107

### General rights

Copyright and moral rights for the publications made accessible in the public portal are retained by the authors and/or other copyright owners and it is a condition of accessing publications that users recognise and abide by the legal requirements associated with these rights.

- ? Users may download and print one copy of any publication from the public portal for the purpose of private study or research.
- ? You may not further distribute the material or use it for any profit-making activity or commercial gain
- ? You may freely distribute the URL identifying the publication in the public portal ?

### Take down policy

If you believe that this document breaches copyright please contact us at [vbn@aub.aau.dk](mailto:vbn@aub.aau.dk) providing details, and we will remove access to the work immediately and investigate your claim.

# Multi-Objective Control of Balancing Systems for Li-Ion Battery Packs: A paradigm shift?

Jorge V. Barreras\*, Cláudio Pinto<sup>‡</sup>, Ricardo de Castro<sup>†</sup>, Erik Schaltz\*, Søren J. Andreassen\*, Rui Esteves Araújo<sup>‡</sup>

\*Department of Energy Technology, Aalborg University, Aalborg, 9220, Denmark

<sup>‡</sup>INESC TEC (formerly INESC Porto) and Faculty of Engineering, University of Porto, Porto, 4200-465, Portugal

<sup>†</sup>Institute of System Dynamics and Control, Robotics and Mechatronics Center

German Aerospace Center (DLR), Wessling, D-82234, Germany

Email: jvb@et.aau.dk, dee12015@fe.up.pt, Ricardo.DeCastro@dlr.de, esc@et.aau.dk, sja@et.aau.dk, raraujo@fe.up.pt

**Abstract**—While a great number of battery balancing circuit topologies have been proposed, the unique control objective typically pursued is equalization of single cell charge. However, a balancing circuit could offer potentially more control features, especially with topologies able to provide bidirectional power flow control. This has not been explored yet in literature or at least not with enough thoroughness. Thus, in addition to charge balancing, up to three more objectives could be pursued simultaneously. Firstly, virtual resistance control, in order to provide dynamic compensation for variations in terminal cell voltage. Secondly, thermal management, to achieve a more uniform temperature distribution within a battery pack. Third, on-board diagnosis or fault detection tools, e.g. to perform characterization tests or to identify and even isolate problematic cells. In this paper, this issue is discussed and evaluated for a battery pack made up of 48 large format Li-Ion cells in series in a e-mobility application. Simulation results demonstrate the technical feasibility of this newly defined concept.

## I. INTRODUCTION

Li-ion cells are interconnected in parallel or in series to increase their current capability or voltage level, respectively, depending on the requirements of the application.

It should be noted that Li-ion cells are electrochemical systems. Hence, they are not ideal voltage sources and uncertainties at the material level are related to the cell-to-cell and lot-to-lot variations [2]–[4]. Each cell has unique self-discharge rate, nominal capacity, impedance and OCV-SoC profile, which are time-varying according to calendar and life cycle conditions [2]–[6].

However, cell-to-cell differences are not a concern in parallel connected cell packs during operation, as soon as the common requirements of industrial standards are satisfied. Intrinsically, if a conducting path exists between parallel connected cells, their voltage level will be self-balanced. Nevertheless, it should be noted that the open circuit voltage difference between the cells should be quite low before the interconnection to avoid high surge currents.

On the other hand, cell mismatch in series or series-parallel connected packs would lead to unwanted or even hazardous situations. If this issue is not tackled properly, the pack performance would always be deteriorated over time, being experienced high degradation rates or permanent damage at cell level. In some cell chemistries could even result into thermal runaway. It should be noted that, even if there is not

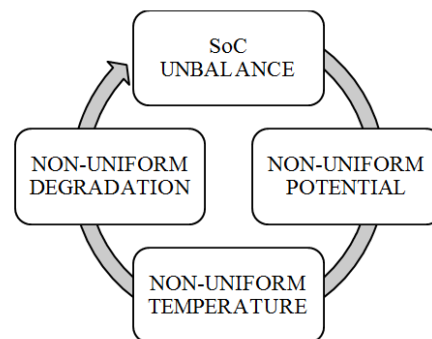

Fig. 1: Cell-to-cell variations/SoC unbalance positive feedback.

initial SoC unbalance, cell-to-cell differences always lead to severe SoC unbalance over time. This process is aggravated due to a positive feedback mechanism: effects of cell-to-cell variations over time induce unbalanced SoC, on the opposite unbalance SoC would increase cell-to-cell variations (Fig. 1). This results from a complex correlation and cross-dependency of ageing mechanisms, which is not easy to quantify. For instance, single cell capacity fade, power fade and other ageing mechanisms are enlarged by extreme SoC/OCV levels or high temperatures [5]–[7].

Therefore, in general, any BMS for a parallel connected battery pack should at least monitor the pack voltage and the pack current, and control the charging/discharging process in order to keep the voltage and the current inside a certain Safety Operating Area (SOA). On the other hand, for the aforementioned reasons, any BMS for a series or series-parallel connected battery pack should monitor as well the single cell voltages. Moreover, if it is a requirement to maintain a proper performance over time, a balancing system shall be included, in order to compensate for cell-to-cell variations. Last, but not least, due to the impact of thermal management on safety and performance of the Lithium Ion Battery (LIB), temperature sensing is a fundamental in any advanced BMS, being a critical issue in applications that demand high management

TABLE I: Conventional versus multi-objective approach

Balancing System	Conventional Approach	Multi-objective Approach
Objective(s)	SoC or Voltage (OCV or terminal) balancing	SoC or Voltage (OCV or terminal) balancing; Virtual equalization of internal resistances; Thermal balancing; On-board diagnosis and fault detection tools.
Balancing method	Dissipative shunt resistor	DC/DC converter <sup>1</sup>
Energy transfer	Passive, unidirectional, cell-to-heat	Active, bidirectional, cell-to-cell shared
Action period	Charging	Charging, discharging and rest (stand-by and storage)
Main components needed for a string of x cells	x Resistors, x Switches	x DC/DC converters <sup>2</sup>
Balancing time	Slow (current level limited by heat dissipation)	Fast
Efficiency	0%	High
Capacity	Limited by the cell <sup>3</sup> with the lowest capacity	Average cell capacity
Power capability	Limited by the cell <sup>3</sup> with the lowest capability	Average cell capability
Temperature distribution	Uniformness of cell temperatures dependent on specific thermal characteristics of the pack	Uniformness improved by thermal balancing
Lifetime	Under normal operation limited by the weakest cell performance in terms of capacity and power fade	Under normal operation limited by the average cell <sup>3</sup> performance in terms of capacity and power fade; Longer life span expected due to more uniform ageing mechanisms;
Control	Simple	Complex
Initial cost	Low	High
Residual pack cost at EOL	Low	Expected High (second life market)
Step response test	No	Yes

requirements, as Smart Grids and Electric Vehicles [7]–[13].

Regarding balancing systems, many different circuits have already been proposed in the literature, which can be roughly divided into active and passive. However, while a great number of circuit topologies have been proposed, typically only two different kinds of control algorithms are proposed, SoC history based and voltage based (terminal or OCV), with the unique objective of equalization of single cell charge [7-13]. Nevertheless, a balancing system could offer more control features that have not been explored yet in literature or at least not with enough thoroughness, especially if bidirectional power flow control is provided. In fact, this new features could improve considerably lifetime and operational performance.

Nowadays, the industry adopts passive balancing systems as a dominant design, due to the additional cost and complexity of more advanced active balancing designs. Improvements on energy efficiency or balancing time are not sufficient to bring a turnaround. Nonetheless, in our view, a proper comparison between conventional and alternative approaches, i.e. multi-objective control, has not been carried out as yet (Table I).

A multi-objective control approach is discussed and evaluated in the present work in order to pursue the question whether or not this may lead to a paradigm shift in the field of balancing systems. The paper is organized as follows. In Section II, this new concept is introduced considering up to four objectives: charge balancing, virtual equalization of internal resistances, thermal balancing and on-board diagnosis and fault detection. Next, the capabilities of a multi-objective approach will be analysed applying convex optimization. Hence, in Section III, simulation models are presented, based

on experimental data from large format Li-ion cells, and an optimal convex problem is formulated. In Section IV, simulation results are presented and discussed. Finally, Section V gives the conclusions.

## II. MULTI-OBJECTIVE CONTROL OF BALANCING SYSTEMS

An introduction to the newly defined concept of multi-objective control of balancing systems is given below, taking into account up to four different objectives. However, on-board diagnosis and fault detection is only addressed conceptually in this work, neither methodologically nor practically.

### A. Equalization of Single Cell Charge

As stated in the introduction, balancing systems are basically divided into active and passive. So called passive balancing circuits are dissipative equalization methods, where energy can only be drawn from single cells through Joule losses, resulting in heat generation. Typically, passive balancing is implemented through a simple resistor in series with a controlled switch. Depending on the level of the bleed current required for the application, passive balancing circuits are implemented either using external switch transistors or just an IC, which already includes the power transistors [7]–[13].

On the other hand, active balancing circuits are non-dissipative equalization methods, where energy can be transferred from cell-to-cell, battery pack to cell and/or cell to battery pack, depending on the circuit topology. As shown in Fig. 2 the active cell balancing methods can be divided into two groups: unidirectional and bidirectional [7]–[13].

Layout approaches of passive and active balancing are shown in Fig. 3. Passive balancing is implemented through an external switch transistor, while active balancing is implemented through one DC-DC converter per cell, allowing bidirectional flow of energy between any single cell and the

<sup>1</sup>Other methods could be proposed, however solutions that offer bidirectional power flow would be preferred.

<sup>2</sup>Special considerations if the number of cells in series is very high.

<sup>3</sup>Or the group of cells in parallel in case of a series-parallel connected pack.

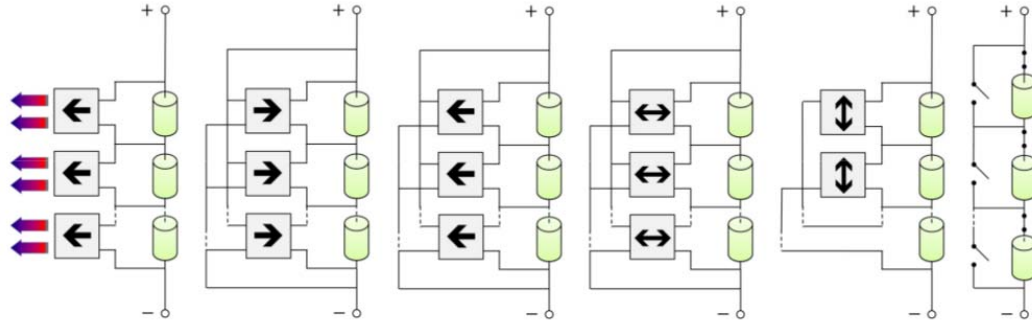

Fig. 2: Energy transfer in passive and active balancing, from left to right: Cell-to-heat (i.e. passive), Pack-to-cell, Cell-to-pack, Cell-to-cell Shared, Cell-to-cell Distributed and Bypass.

battery pack [7]–[13]. Passive balancing is typically used only during charging process; otherwise a loose of total capacity would be noted. Whereas, active balancing is proposed during charging, discharging or rest periods. Rest periods may include stand-by or quiescence periods and storage periods.

### B. Terminal Voltage Equalization Towards Virtual Equalization of Internal Resistance

A balancing circuit could be controlled as virtual resistance in order to provide dynamic compensation for variations in terminal voltage due to cell-to-cell impedance differences. In that case the balancing circuits would inject or draw a limited current in order to emulate negative or positive virtual resistances in series with every single cell.

As a result, this new approach can provide, up to some extent, virtual equalization of single cell internal resistances, i.e. power capabilities or State-of-Function (SoF). This is an interesting feature investigated in this paper, allowing an extended battery operating range, the key bottle-neck in many battery applications.

### C. Thermal Balancing

A balancing circuit could be also used for thermal balancing purposes, in order to achieve a more uniform temperature distribution within a battery pack. Under extreme current demands, the battery balancing circuit could increase or decrease single cell charging or discharging current, injecting

or drawing current, or even bypassing a cell. Since heat generation in an electrochemical cell depends on the square value of the current (Joule heating), this could be used to control, up to certain level, heat generation at single cell level. Recently, thermal balancing has been proposed using a multi-level converter as an integrated cell balancer and motor driver for application in e-mobility [14], but this could be achieved as well through non-integrated approaches.

### D. On-board Diagnosis and Fault Detection

Last but not least, balancing circuits could be also controlled as on-board diagnosis and fault detection tools, to perform e.g. pulse characterization tests, suitable for further parameterization of LIB models or to identify problematic cells. Moreover a balancing system could even isolate problematic cells trough real or virtual bypass isolation. The latter was already proposed in [13] to ensure operability of a vehicle in worst case scenario (limp home or turtle mode of operation).

## III. CELL BALANCING PROBLEM FORMULATION

In order to validate the proposed concepts, an exemplary multi-objective control approach is implemented in simulation according to the active system from Fig. 3 and using a predefined battery pack current profile from a standard drive cycle covered by a Battery Electric Vehicle (BEV). Then, an optimal convex problem is formulated in order to determine the optimal current values of each DC/DC converter for that pack current profile. Simpler battery cell models, linear static (*LS*), are proposed to solve the optimal problem. Later on, a simulation is run using more complex battery models, non-linear dynamic (*NLD*), considering the values of the currents obtained previously for each of the DC/DC converters.

### A. Battery Models

Two electrical models  $\mathcal{M} \in \{LS, NLD\}$  with different levels of complexity will be considered, with both of them represented through Equivalent Circuit Models (ECMs) [15], see Fig. 4. The ECMs are mathematically characterized as:

$$v_j(t) = OCV_j(q_j(t)) - \Delta v_j(t), \quad j \in \mathcal{M} \quad (1a)$$

$$\dot{q}_j(t) = -\frac{1}{Q_j} i_j(t) \quad (1b)$$

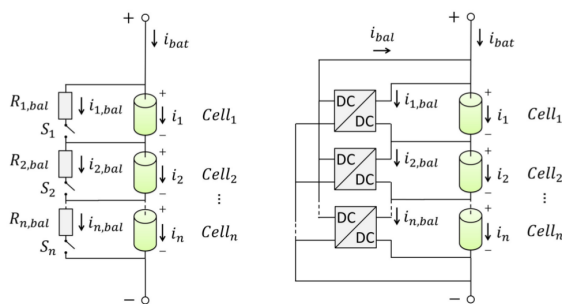

Fig. 3: Exemplary passive (left) and active (right) balancing circuit topologies.

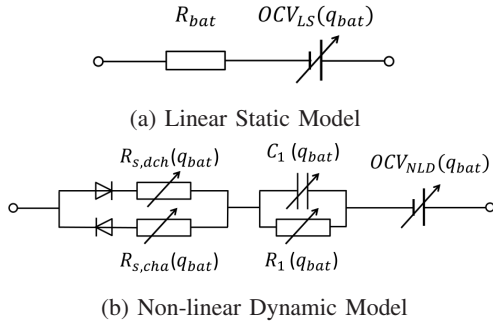

Fig. 4: Battery cell's Equivalent Circuit Models

where  $v_j$  is the output voltage of the cell,  $OCV_j$  the cell's open-circuit voltage, and  $\Delta v_j$  the voltage drop in the cell's internal impedance. The state of charge (SoC) is given by  $q_j$ , the maximum charge of the cell by  $\bar{Q}_j$ , and the cell's current by  $i_j (\in \mathbb{R})$ . Normally, the current, the SoC and the terminal voltage of the cell are constrained by physical limits:

$$i_j^{min} \leq i_j(t) \leq i_j^{max} \quad (2a)$$

$$q_j^{min} \leq q_j(t) \leq q_j^{max} \quad (2b)$$

$$v_j^{min} \leq v_j(t) \leq v_j^{max} \quad (2c)$$

The parameterization of the Li-ion battery ECMs was based on experimental data, for further details see [15].

**Linear Static Model ( $j = LS$ ):** The first cell model assumes linear OCV and a constant internal resistance of the cell. It is defined as:

$$OCV(t) = a + b \cdot q(t) \quad (3)$$

$$\Delta v(t) = R_{bat} i(t) \quad (4)$$

where  $(a, b, R_{bat})$  are parameters of the  $LS$  model. Notice that, in order to simplify the notation, the sub-indexes of the variables ( $OCV, q, \Delta v, i$ ) were omitted.

**Non-linear Dynamic Model ( $j = NLD$ ):** The second model, also takes into account SoC-related nonlinearities and first-order dynamics in the ESS's cells. These nonlinearities are approximated using piecewise linear (PWL) functions. In order to formulate them, let us divide the  $q$  range in  $N_p$  sub-intervals,  $[q_k, \bar{q}_k]$ ,  $k \in [1, N_p]$  where  $q_k$  and  $\bar{q}_k$  are the interval limits.

$$OCV(t) = \sum_{k=1}^{N_p} (u_{0k} + u_{1k} q(t)) B(k, q(t)) \quad (5)$$

$$\Delta v(t) = R_s(q(t)) i(t) + \Delta v_c(t) \quad (6)$$

$$\frac{d\Delta v_c(t)}{dt} = \frac{1}{C_1(q(t))} \left( i(t) - \frac{\Delta v_c(t)}{R_1(q(t))} \right) \quad (7)$$

where  $u_{0k}$  and  $u_{1k}$  are parameters and  $B(k, q)$  is an indicator function that returns 1 if  $q \in [q_k, \bar{q}_k]$  and 0 otherwise. The same way, variables  $R_s(q(t))$ ,  $C_1(q(t))$  and  $R_1(q(t))$  are approximated by PWL functions, further details in [15].

**Thermal Model:** Assuming that the battery cell thermal behaviour can be described through a lumped capacitance

model, the differential equation that governs the temperature of the cell  $T$  can be written as follows [16]:

$$\frac{d\Delta T_j(t)}{dt} + \frac{hA}{m_{PC,bat} C_p} (T_j(t) - T_{env}) = \frac{P_{loss_j}(t)}{m_{PC,bat} C_p} \quad (8)$$

where  $m_{PC,bat}$  is the mass of the cell,  $C_p$  is the specific heat of the cell,  $h$  is the heat transfer coefficient of the cell external surface to the environment,  $A$  is the area of the external surface of the cell,  $T_{env}$  is the environment temperature and  $P_{loss_j}$  is the internal power losses of the battery cell.

## B. Pack Current Balance

In what follows, we will formulate a convex cell-balancing optimization problem. Our interest in adopting a convex formulation is motivated by the well-known fact that global optimal solutions for the (cell-balancing) problem can be obtained (see [17]). In order to facilitate the formulation of the convex cell-balancing optimization, three main approximations will be adopted. First,  $LS$  battery models will be used in the optimization problem (notice that (1), (3) and (4) are affine, and (2) is linear, thus convex). Second, we will ignore the power losses from the converters of the balancing circuits. The third approximation is the enforcement of a current-balance constrain (instead of a power-balance) in the problem; in other words, the net sum of the currents injected by the BMS's balancing circuit in the cells  $i_{c,bal}(t)$  should be zero, i.e.,

$$\sum_{c=1}^{N_c} i_{c,bal}(t) = 0, \quad i_{bat}(t) = i_c(t) + i_{c,bal}(t) \quad (9)$$

where  $c \in \{1, \dots, N_c\}$  represents each of the battery cells of a string made up of  $N_c$  cells and  $i_{bat}(t)$  is the predefined pack current profile. Although, in practice, the BMS's balancing circuit should impose a power balance (i.e, the net power injected by the BMS is zero) the validation results shown in Section IV demonstrate that the power errors introduced by this approximation are reduced. Nevertheless, the major advantage of this formulation is that the resulting currents can be applied directly to a more realistic battery model maintaining at least the expected SoC balance. Additionally, another constraints that should be ensured are the maximum and minimum currents ( $i_{dc}^{min}, i_{dc}^{max}$ ) allowed by the DC/DC converters of the BMS. Hence, the difference between current pack and cell pack should respect:

$$i_{dc}^{min} \leq i_{c,bal}(t) \leq i_{dc}^{max} \quad (10)$$

## C. Optimal Problem Formulation

In this proposal the formulated optimal problem pursues three objectives simultaneously: single cell charge equalization, terminal voltage equalization (virtual equalization of internal resistances) and thermal balancing. Three types of (convex) costs will be considered. The first one, for charge equalization, is given by:

$$J_{SoC}(t) = \sum_{c=1}^{N_c} (q_c(t) - \bar{q}(t))^2 \quad (11)$$

where  $\bar{q}(t) = \sum_{c=1}^{N_c} \frac{q_c(t)}{N_c}$  is the mean SoC of the pack. The second cost penalizes the power losses  $P_{loss,c}(t) = \alpha_c R_{bat} i_c^2(t)$ , which according to our thermal model (8) are responsible for the heat generation. The term  $\alpha$  is a gain that accounts for cell-to-cell variation in internal resistance, where  $\alpha = 1$  represents a mean cell. The cost is given as follows:

$$J_{Temp}(t) = \sum_{c=1}^{N_c} P_{loss,c}(t) \quad (12)$$

The third cost is emphasized when the terminal voltages are approaching a certain threshold  $v^{lim}$ :

$$J_{Vt}(t) = \sum_{c=1}^{N_c} e^{v^{lim} - v_j(t)} \quad (13)$$

Finally, the total considered cost for the complete drive cycle with duration  $T_{DC}$  is given by:

$$\mathcal{J} = \int_0^{T_{DC}} (w_1 J_{SoC}(t) + w_2 J_{Temp}(t) + w_3 J_{Vt}(t)) dt \quad (14)$$

Accomplishing each of the objectives separately leads to different current behaviors. In that sense, in a multi-objective formulation a trade-off is required between these objectives. Hence, the weights  $w_n$  (with  $n \in \{1, \dots, 3\}$ ) were introduced. Therefore, the defined convex problem for a discrete finite time horizon (with sample time  $T_s = 1s$ ) is defined as follows:

*minimize*

$$\mathcal{J} = \sum_{k=0}^{T_{DC}} (w_1 J_{SoC}(k) + w_2 J_{Temp}(k) + w_3 J_{Vt}(k))$$

*subject to:*

$$v_c(k) = OCVC(q_c(k)) - \Delta v_c(k), \Delta v_c(k) = \alpha_c R_{bat} i_c(k)$$

$$q_c(k+1) = q_c(k) - \frac{T_s i_c(k)}{Q_c}, q_c(0) = SoC_{ini}$$

$$q_c^{min} \leq q_c(k) \leq q_c^{max}$$

$$\sum_{c=1}^{N_c} i_{c,bal}(k) = 0, \quad i_{bat}(k) = i_c(k) + i_{c,bal}(k)$$

$$i_{dc}^{min} \leq i_{c,bal}(k) \leq i_{dc}^{max}, \quad i_c^{min} \leq i_c(k) \leq i_c^{max}$$

$$w_1, w_2, w_3 \in \mathbb{R}^+, \quad c \in \{1, \dots, N_c\}, \quad k \in \{0, \dots, T_{DC}\}$$

#### IV. CASE STUDY

The proposed multi-objective approach was applied to an exemplary case, considering an active balancing circuit topology able to provide bidirectional power flow control (Fig. 3), connected to a battery pack made up by 3 large format Li-ion cells in series. The described methodology was implemented in Matlab. The proposed convex problem was parsed with YALMIP [18] and solved with Ipopt [19].

TABLE II: LIB [per cell] and BMS Parameters

Variable	Symbol	Value	Unit
Pouch Cell Mass	$m_{PC,bat}$	1.2	kg
Nominal voltage	$v_{bat}$	3.7	V
Nominal capacity	$\bar{Q}_{bat}$	53	A.h
Actual capacities	$\bar{Q}_{bat}$	54.3/51.4/53	A.h
Initial SoC	$SoC_{ini}$	0.67/0.65/0.64	-
Parameter's gain	$\alpha$	0.5/3/1	-
SoC limits	$[q_{bat}^{min}, q_{bat}^{max}]$	[0.05,0.95]	-
Current limits	$[i_{bat}^{min}, i_{bat}^{max}]$	[-106,265]	A
DC/DC current limits	$[i_{dc}^{min}, i_{dc}^{max}]$	[-26.5,26.5]	A
Voltage limits	$[v_{bat}^{min}, v_{bat}^{max}]$	[2.7,4.2]	V
Specific heat	$C_p$	0.9m <sub>PC,bat</sub>	J/(cell.K)
Heat transfer coefficient	$h$	10	W/(K.m <sup>2</sup> )
External surface area	$A$	0.082	m <sup>2</sup>
Environment temperature	$T_{env}$	25	°C

#### A. Selection of Li-ion Cells

Validation is presented for Kokam SLPB 120216216 53Ah Li-Ion pouch technology. This kind of cells are becoming more popular for applications where a multi-objective control may be a capital gain, such BEVs (e.g. Ford Focus electric, Nissan Leaf) and PHEVs (e.g. Chevrolet Volt, Cadillac ELR), target markets for second use battery programs [13], [20].

Traction or high power applications take intrinsically more advantage due to higher current levels and increased management requirements. Moreover series-parallel connected packs made up of small cells can be replaced by series connected battery packs made up of larger cells, where cell-to-cell variations are more pronounced since there is no self-equalization effect. Furthermore, pouch cells are lighter and less bulky due to the lack of enclosure. Regarding cost, using large capacity cells, the number of interconnections between cells is minimized [21]. On the other hand, safety issues are related to large cells, owing to the intrinsically larger amount of energy contained in a single cell [21]. Long-term performance under different operating/environmental conditions is still an active field of study [6], [22], [23].

#### B. Battery Pack Current Profile

With respect to the pack current profile  $i_{bat}(t)$ , it was determined by simulation of a BEV over a standard Artemis Rural Road Driving Cycle. It is assumed that the powertrain is composed by the following components: a mechanical transmission, an electric motor, DC/DC converters and a battery pack made up of 48 cells in series (approximated 9.4kWh).

This drive cycle was repeated 3 times starting at 65% SoC, considering an aggregated battery model. For the sake of brevity, additional details are omitted here (the interested reader is referred to [15]).

#### C. Simulation Results

The optimal DC/DC converters current set points obtained for LS battery cell models were applied to NLD models, obtaining a sub-optimal solution. Simulation results with and without control are shown in Fig. 5, taking into account LIB and BMS parameters listed in Table II. It is clear that beyond a fast and efficient SoC-based equalization of single cell charge,

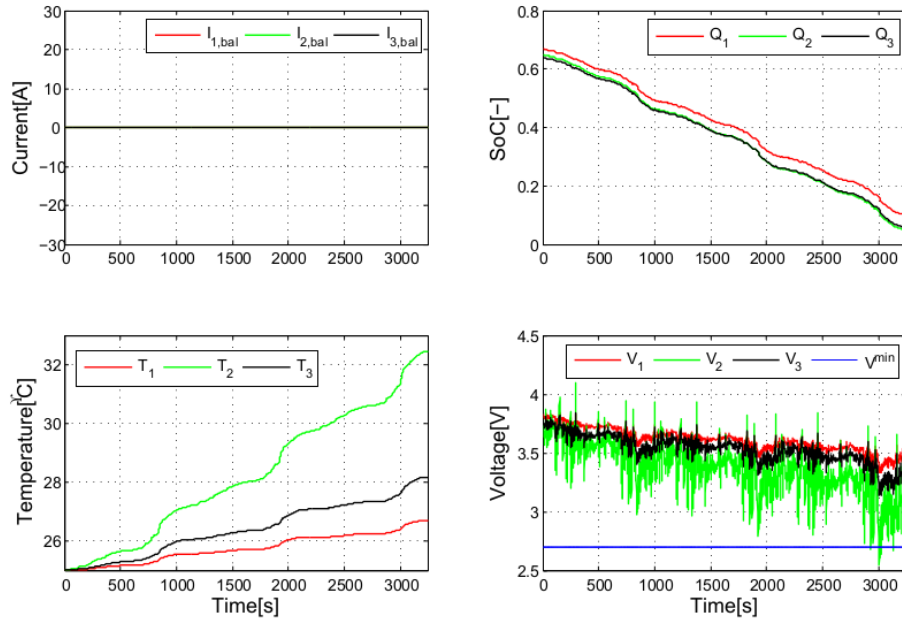

(a) Results without control.

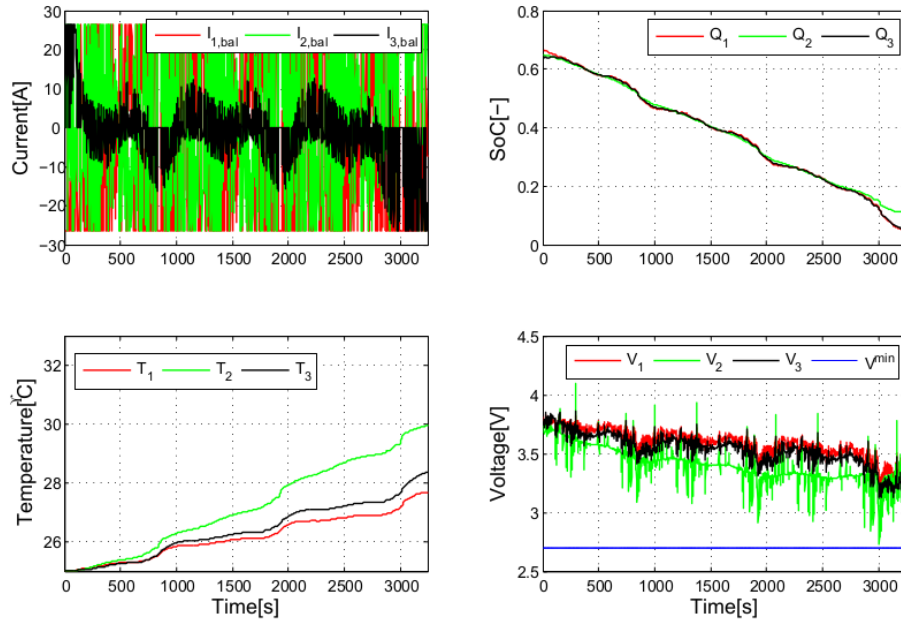

(b) Results with control.

Fig. 5: Simulation results from the multi-objective control approach applied to NLD models.

a more uniform temperature within the pack was achieved, reducing the temperature differential from 6°C to less than 3°C and decreasing the maximum cell's temperature in about 2.5°C. Regarding the currents of the DC/DC converters, results show that the larger energy flux is between cells with the highest cell-to-cell variation of internal parameters (cell 1 and cell 2). Moreover set current limits are reached often for those cells, which identify them as key design variables. It was also observed a deliberate SoC unbalance at very low SoC, required to extend the battery range with full-power

capability by more than 6.5 km or 5 min. Such SoC unbalance it is positive for the pack since it promotes a more uniform evolution of cell internal parameters, protecting more aged cells, i.e. cells with lower power capability. Therefore the performance of the pack with multi-objective control it is not strictly conditioned by the weakest cell in terms of capacity, power capability or surface temperature.

## V. CONCLUSIONS

The proposed multi-objective approach was applied to an exemplary case, where the optimal set points of each of the DC/DC converters of the balancing circuit were determined by solving a convex problem with three-objectives. Results were presented for a specific group of three cells of the battery pack with significant cell-to-cell variation of internal parameters.

The discussions and results introduced in this study indicated that a multi-objective control approach is a valid strategy to achieve at least the following objectives:

- Improved performance: higher capacity, power capability, efficiency or fast charging capability and shorter charging time.
- Prolonged lifetime: more uniform ageing mechanisms, i.e. power and capacity fade and other mechanisms, due to better SoC/voltage equalization and more uniform temperature distribution.
- Improved or additional features: bypass isolation (limp home or turtle mode of operation), self-discharge equalization during long term storage, fault detection and improved BMS analysis functions: more accurate estimation of single cell states due to implementation of on-board diagnosis tools.

Thus from a strictly technical point of view the advantages are clear. However, in order to determine the question whether or not this may lead to a paradigm shift in control of balancing systems a techno-economic analysis it is needed and will be included in future publication.

To its advantage, the promising market of second life batteries will be benefited from the application of a multi-objective approach, due to reduced uncertainty of degradation rates and lower costs of battery integration. In purely economic terms: higher initial costs may be compensated by longer life span and possibility to obtain an economic return for the battery residual value at End-of-Life. To its disadvantage, the binomial performance-cost is strongly dependent on the balancing system features (ability to provide bi-directional power, level of power or current flow, number of cells controlled simultaneously,...), battery pack characteristics (series-parallel arrangement, type of cells, cell-to-cell variations, heating/cooling system,...) and external conditions (environmental temperature, driving profiles,...).

## ACKNOWLEDGMENT

The authors acknowledge the support from the Danish Strategic Research Council of the project Advanced Lifetime Predictions of Battery Energy Storage and Portuguese National Funds through FCT by the scholarship SFRH/BD/90490/2012.

## REFERENCES

- [1] Electronic Design. Design A Linear Li-ion Battery Charger For Portable Systems. Internet: [www.electronicdesign.com/energy/design-linear-li-ion-battery-charger-portable-systems](http://www.electronicdesign.com/energy/design-linear-li-ion-battery-charger-portable-systems), May 7, 2009 [April 8, 2014].
- [2] A. Jossen, "Fundamentals of battery dynamics," *Journal of Power Sources*, 154 (2006) 530-538.
- [3] Santhanagopalan S.; White R. E., Quantifying Cell-to-Cell Variations in Lithium Ion Batteries, *International Journal of Electrochemistry*, vol. 2012, Article ID 395838, 10 pages, 2012. doi:10.1155/2012/395838
- [4] Donghwa S.; Poncino, M.; Macii, E.; Naehyuck C., "A statistical model of cell-to-cell variation in Li-ion batteries for system-level design," *Low Power Electronics and Design (ISLPED)*, 2013 IEEE International Symposium on , vol., no., pp.94,99, 4-6 Sept. 2013. doi: 10.1109/ISLPED.2013.6629273
- [5] J. Vetter, P. Novk, M.R. Wagner, C. Veit, K.-C. Miller, J.O. Besenhard, M. Winter, M. Wohlfahrt-Mehrens, C. Vogler, A. Hammouche, Ageing mechanisms in lithium-ion batteries, *Journal of Power Sources*, Volume 147, Issues 12, 9 September 2005, Pages 269-281, ISSN 0378-7753, <http://dx.doi.org/10.1016/j.jpowsour.2005.01.006>.
- [6] A. Barré, B. Deguilhem, S. Grolleau, M. Grard, F. Suard, D. Riu, A review on lithium-ion battery ageing mechanisms and estimations for automotive applications, *Journal of Power Sources*, Volume 241, 1 November 2013, Pages 680-689, ISSN 0378-7753, <http://dx.doi.org/10.1016/j.jpowsour.2013.05.040>.
- [7] Cao, J.; Schofield, N.; Emadi, A., "Battery balancing methods: A comprehensive review," *Vehicle Power and Propulsion Conference (VPPC)*, 2008 IEEE , vol., no., pp.1,6, 3-5 Sept. 2008. doi: 10.1109/VPPC.2008.4677669
- [8] Moore S.; Schneider P., A Review of Cell Equalization Methods for Lithium Ion and Lithium Polymer Battery Systems," in *Proceedings of the SAE 2001 World Congress*, 2001.
- [9] Zhi-Guo K.; Chun-Bo Z.; Ren-Gui L.; Shu-Kang C., Comparison and Evaluation of Charge Equalization Technique for Series Connected Batteries, *37th IEEE Power Electronics Specialists Conference*, pp. 1-6, 2006.
- [10] Daowd, M.; Omar, N.; Van den Bossche, P.; Van Mierlo, Joeri, "Passive and active battery balancing comparison based on MATLAB simulation," *Vehicle Power and Propulsion Conference (VPPC)*, 2011 IEEE , vol., no., pp.1,7, 6-9 Sept. 2011. doi: 10.1109/VPPC.2011.6043010
- [11] Einhorn, M.; Roessler, W.; Fleig, J. "Improved Performance of Serially Connected Li-Ion Batteries With Active Cell Balancing in Electric Vehicles", *Vehicular Technology, IEEE Transactions on*, On page(s): 2448 - 2457 Volume: 60, Issue: 6, July 2011.
- [12] Rahimi-Eichi, H.; Ojha, U.; Baronti, F.; Chow, M., "Battery Management System: An Overview of Its Application in the Smart Grid and Electric Vehicles," *Industrial Electronics Magazine, IEEE*, vol.7, no.2, pp.4,16, June 2013. doi: 10.1109/MIE.2013.2250351
- [13] Einhorn, M.; Guertlschmid, W.; Blochberger, T.; Kumpusch, R.; Permann, R.; Conte, F.V.; Kral, C.; Fleig, J., "A Current Equalization Method for Serially Connected Battery Cells Using a Single Power Converter for Each Cell," *Vehicular Technology, IEEE Transactions on*, vol.60, no.9, pp.4227,4237, Nov. 2011. doi: 10.1109/TVT.2011.2168988
- [14] F. Altaf, L. Johannesson, B. Egardt, "On Thermal and State of-Charge Balancing using Cascaded Multi-level Converters," *Journal of Power Electronics*, vol. 13, Issue 4, pp. 569-583, 2013.
- [15] C. Pinto, J. V. Barreras, R. de Castro, E. Schaltz, S. J. Andreasen, R. E. Araujo, "Influence of Li-ion Battery Models in the Sizing of Hybrid Storage Systems with Supercapacitors," presented at the *Vehicle Power and Propulsion Conference (VPPC)*, Coimbra, 2014.
- [16] L. Gao, S. Liu, R. A. Dougal, Dynamic Lithium-Ion Battery Model for System Simulation, *IEEE Transactions on Components and Packaging Technologies*, vol. 25, no. 3, September 2002.
- [17] S. Boyd and L. Vandenberghe, *Convex Optimization*: Cambridge University Press, 2004.
- [18] J. Lfberg, "YALMIP : A Toolbox for Modeling and Optimization in MATLAB. J.Lfberg. In *Proceedings of the CACSD Conference*, Taipei, Taiwan, 2004.
- [19] Wchter and L. T. Biegler, On the Implementation of a Primal-Dual Interior Point Filter Line Search Algorithm for Large-Scale Nonlinear Programming, *Mathematical Programming* 106(1), pp. 25-57, 2006
- [20] Cicconi, P.; Landi, D.; Morbidoni, A.; Germani, M., "Feasibility analysis of second life applications for Li-Ion cells used in electric powertrain using environmental indicators," *Energy Conference and Exhibition (ENERGYCON)*, 2012 IEEE International , vol., no., pp.985,990, 9-12 Sept. 2012. doi: 10.1109/EnergyCon.2012.6348293
- [21] G. Pistoia, *Lithium-Ion Batteries: Advances and Applications*, ISBN-13: 978-0444595133.
- [22] J. Cannarella; C.B. Arnold, Stress evolution and capacity fade in constrained lithium-ion pouch cells, *Journal of Power Sources* 245 (2014) 745-751.
- [23] J. A. Jeevarajan, Safety and Long-term Performance of Lithium-ion Cells in a Pouch Format, *The Electrochemical Society*, Abstract 999, Honolulu PRiME 2012.