



Aalborg Universitet

AALBORG UNIVERSITY
DENMARK

Flexible Local Load Controller for Fast Electric Vehicle Charging Station Supplemented with Flywheel Energy Storage System

Dragicevic, Tomislav; Sun, Bo; Schaltz, Erik; Guerrero, Josep M.

Published in:

Proceedings of the IEEE International Electric Vehicle Conference 2014 (IEVC)

DOI (link to publication from Publisher):

[10.1109/IEVC.2014.7056133](https://doi.org/10.1109/IEVC.2014.7056133)

Publication date:

2014

Document Version

Early version, also known as pre-print

[Link to publication from Aalborg University](#)

Citation for published version (APA):

Dragicevic, T., SUN, B. O., Schaltz, E., & Guerrero, J. M. (2014). Flexible Local Load Controller for Fast Electric Vehicle Charging Station Supplemented with Flywheel Energy Storage System. In Proceedings of the IEEE International Electric Vehicle Conference 2014 (IEVC) (pp. 1-6). IEEE Press. DOI: 10.1109/IEVC.2014.7056133

General rights

Copyright and moral rights for the publications made accessible in the public portal are retained by the authors and/or other copyright owners and it is a condition of accessing publications that users recognise and abide by the legal requirements associated with these rights.

- ? Users may download and print one copy of any publication from the public portal for the purpose of private study or research.
- ? You may not further distribute the material or use it for any profit-making activity or commercial gain
- ? You may freely distribute the URL identifying the publication in the public portal ?

Take down policy

If you believe that this document breaches copyright please contact us at vbn@aub.aau.dk providing details, and we will remove access to the work immediately and investigate your claim.

Flexible Local Load Controller for Fast Electric Vehicle Charging Station Supplemented with Flywheel Energy Storage System

Tomislav Dragičević, Sun Bo, Erik Schaltz, and Josep M. Guerrero

Department of Energy Technology

Aalborg University

9220 Aalborg East, Denmark

e-mails: tdr@et.aau.dk, sbo@et.aau.dk, esc@et.aau.dk, and joz@et.aau.dk

www.microgrids.et.aau.dk

Abstract—Electric vehicle charging infrastructure is hitting the stage where its impact on performance and operation of power systems becomes more and more pronounced. Aiming to utilize the existing power distribution infrastructure and delay its expansion, an approach that includes installation of dedicated flywheel energy storage system (FESS) within the charging station and compensating some of the adverse effects of high power charging is explored in this paper. Although sharing some similarities with vehicle to grid (V2G) technology, the principal advantage of this strategy is the fact that many types of ancillary services can be provided to the grid without affecting the charging patterns of EV batteries, thus prolonging their lifetime and increasing the drivers' comfort level at the same time. Additionally, since the strategy is designed with a distributed bus signaling (DBS) method, it enables the operation without dedicated communication technologies, while allowing easy expandability and inherent plug and play functionality. This paper focuses on a near-future scenario with a high number of fast charging stations spread across the power system that impact the systems real time regulation capability. As a demonstrative example, a particular system-level control algorithm has been tailored towards to specific configuration of the fast charging station used in this paper, which includes FESS. Algorithm has been developed in Matlab/Simulink and compiled to real-time simulation platform dSPACE 1103. Corresponding simulation results have been reported in order to verify the validity of proposed approach.

Index Terms—Fast charge station (FCS), plug-in hybrid electric vehicle (PHEV), DC-bus signaling (DBS), flywheel.

I. INTRODUCTION

THE last decade has been marked by global concerns related with air-pollution and reduction of fossil fuel reserves. In turn, it has been recognized that the increase in the share of renewable energy resources (RES) in total electrical energy production is a vital strategic goal for sustainable development. In relation with this, major efforts at both technical and political level have been undertaken to prepare the electric utilities for large-scale integration of RES [1], [2].

On the other hand, greater electrification of the transport sector by introducing the concept of a more electric vehicle

(MEV) opens up many possibilities for supporting an on-going utility shift towards cleaner electricity since this sector currently accounts for more than a quarter of the world's carbon dioxide emissions [3]. MEV architecture strongly underpins the current trends in automotive industry where more and more attention is devoted to the increase of the customer comfort level in terms of installing various additional electrical appliances [4]. By replacing whole or part of the propulsion system in conventional vehicles with electrical engines and using the grid power for recharging the MEV's battery pack, an on-going utility shift towards cleaner electricity may be conveyed to the transportation sector as well.

Furthermore, in many Smart Grid strategies of developed countries around the world, flexible consumption has been recognized as a key for large-scale integration of RES. In this regard, as electric vehicles (EVs) are expected to constitute a considerable portion of the total system load in near future, smart coordination of their recharging patterns will hide a great flexibility potential. Governments are therefore stimulating new owners of EVs with alluring incentives, vigorously promoting their wide adoption. However, as number of these kinds of vehicles on the roads steadily increases, quite the contrary effect will arise if this potential is not wisely used. As the matter a fact, today's distribution networks were not initially designed envisioning these kinds of heavy loads [5]–[7].

By now, industry has defined three types of charging which relate to maximum power transferred from the grid to plug-in EV. Out of them, fast DC charging with power of more than 50 kW (commonly referred to as level three) appears to be the most favorable option for public sites since it offers the shortest off-road time to hurrying vehicle owners, relating directly to their comfort level. Bearing in mind that the future EV charging infrastructure will comprise all three types of chargers, this paper is primarily focused on fast chargers since their impact will be the most significant. In that sense, network upgrade will be an inevitable eventual step that will enable a wider acceptance of EVs. However, the goal of this paper is

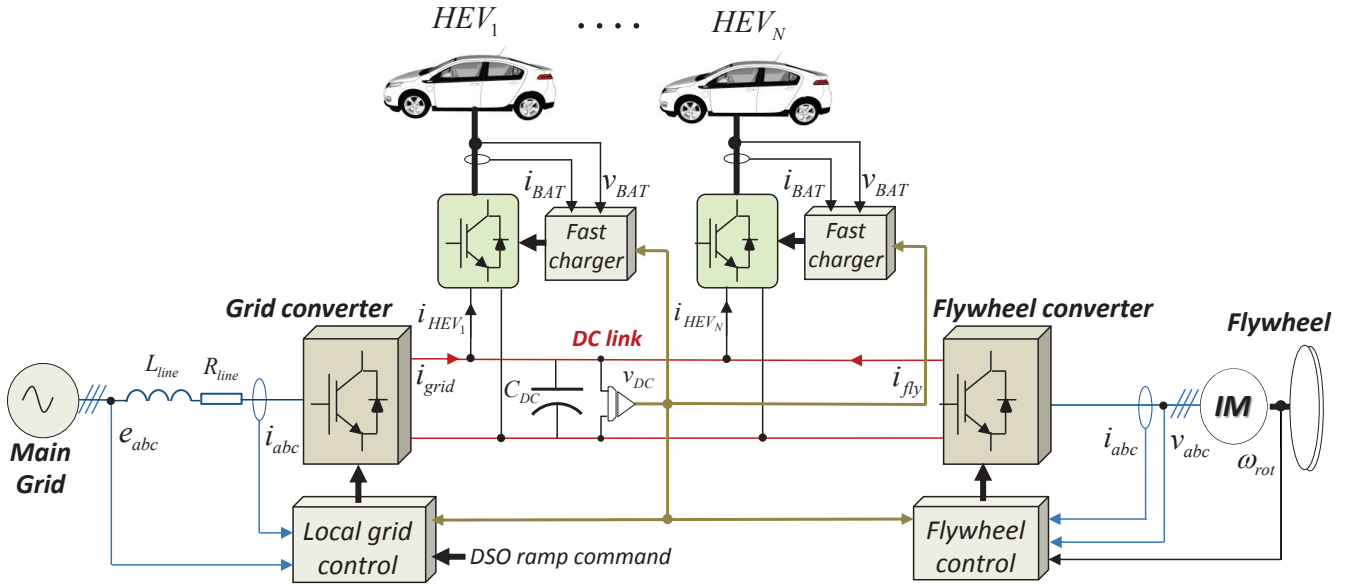

Fig. 1. Configuration of the charging station with dedicated flywheel ESS device.

to demonstrate how this extension can be deferred by utilizing dedicated energy storage systems (ESS) installed within the level-three charging stations.

Unlike previously proposed approaches for mitigating adverse effects, here a dedicated ESS device is installed within the charging station, and is able to provide services similar as vehicle to grid (V2G) technology. Owing to the fact that recharging pattern of the vehicle is not compromised, result is a prolonged HEV battery life-time, but at a cost of additional investment. It should be noted that the cost-effectiveness of this investment depends on a number of factors such as the characteristics of ESS technology, frequency of EVs connection, associated recharging rates, strength of the distribution grid, price of electricity, grid codes, relation of vehicle drivers comfort level to price that they are will to pay, and others. Therefore, the potential complexity of this analysis would require an in-depth and separate study that is out of the scope of this paper but which presents a fertile future research direction. The final objective in that sense would be to determine in which scenarios is it viable to deploy ESS within the charging station and which ESS technology in particular should be used. Simultaneously with the above, it should be determined how much energy and power capacity should it utilize.

On the other hand, in line with previous work done by the authors, flywheel ESS driven by an induction machine (IM) is considered as the most appropriate technology for providing specific, typically quick power compensation services, since it is a rugged and cheap system that has high power density and doesn't have problems with degradation [8], as batteries have. Its usage in grid-connected applications has been well documented [9]–[12]. However, as elaborated in [8], the principal difference between the control approach here and aforementioned ones is that a high bandwidth communication between the flywheel converter (FC) and grid converter (GC)

is not needed as supervisory control is fully decentralized. In particular, a distributed bus signaling (DBS) strategy, previously used for control of DC microgrids [13], [14], [15] has been applied for internal coordination between units.

However, basic version of DBS has been modified here to accommodate FESS technology. More details about this modification can be found in [8], [16] and are also shortly revised in Section II for the sake of completeness of the paper. The particular contribution of this paper is integration of the algorithm originally developed for large-scale control and coordination of clusters of controllable loads [17] together with recently developed FESS tailored DBS strategy.

The paper is organized as follows. Section II demonstrates the configuration of FCS. In Section III the principle of the large-scale HEV aggregation charging algorithm is revealed. It is also indicated how the same structure can be directly expanded to use paralleled number of flywheel ESS in achieving the same functionality. In Section IV, a real-time simulation results that validate the proposed strategy are presented. Paper is finalized with a conclusion and indication of future research directions given in Section V.

II. CONFIGURATION OF THE EV CHARGING STATION

A single line block diagram of a typical charging station is shown in Fig. 1. It comprises a grid tied inverter that establishes a common dc link to which dc/dc converters with implemented charging algorithms are connected. In addition, ESS systems can be installed at the dc link due to two principal reasons, i.e. to avoid overmodulation of inverters, and to be able to recharge vehicles with buck-type dc/dc converters. For that matter, a nominal value of 650Vdc was used in this study.

It is essential to achieve a coordinated operation of different converters in the system. To that end, it is necessary to establish a line of communication between them. Conventionally,

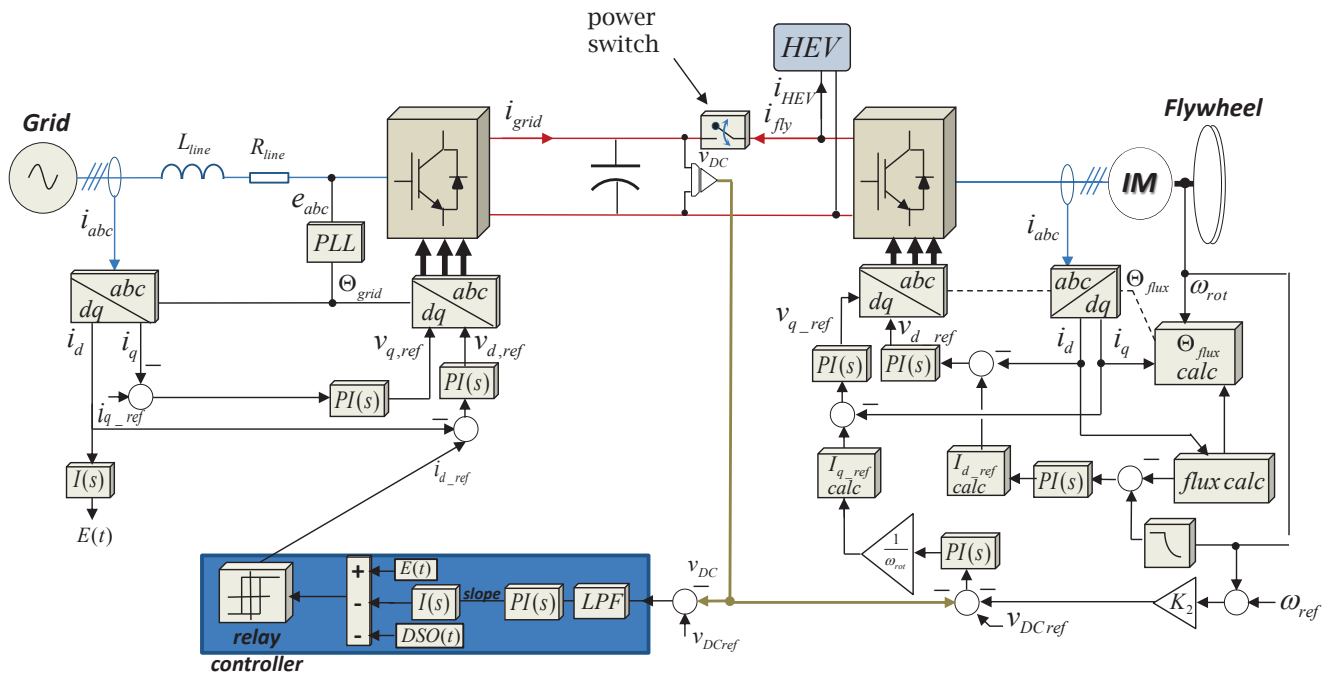

Fig. 3. Overall control diagram that incorporates hysteresis controller.

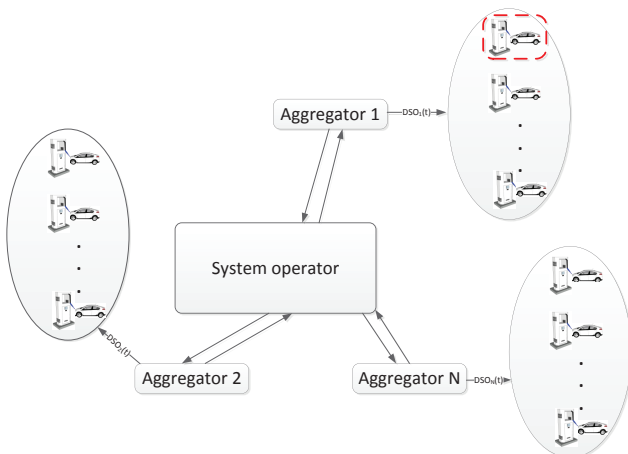

Fig. 2. Schematic representation of the system level control scheme.

this is realized by means of a centralized supervisory controller which gathers data from different converters via digital communication links. In this case, control algorithm of flywheel converter utilizes dc link voltage loop supplemented by the additional power reference obtained from supervisory control [12]. Some other works do not use supervisory controller, but their ideas are presented only at conceptual level, focusing on internal control loops, not on a full solution with practical applicability [18], [10].

Here, the proposed approach does not rely on a centralized supervisory controller, but on a decentralized strategy. However, unlike other decentralized approaches, it is fully operable.

It relies on the principle of sharing information about the status of different converters through voltage variations of the dc link. In that sense, there are several key aspects that need to be taken into account and closely monitored. They can be listed as follows:

- 1) Control over the state of charge (SOC) of ESS system to avoid overcharge and overdischarge conditions
- 2) Power exchange between grid converter and distribution network should respect the imposed rules, either following real-time commands by the distribution system operator (DSO) or following automatic control strategy installed within the station.
- 3) Plug and play feature for seamless installation of additional HEV chargers and ESS should be inherently incorporated in control and hardware design

Remaining energy in ESS is often referred to as SOC, particularly in cases when electrochemical batteries are used as ESS. An adaptive droop method is popular approach for balancing SOC among number of batteries [15], [19]. It is basically a DBS method that uses SOC for calculation of the associated droop coefficient which determines deviation of the common bus voltage from the nominal value ¹. A slight variation of this scheme is deployed here in order to tailor it to the special features of the FESS and rather than inductor current, flywheel speed is used as feedback droop variable. In that way, remaining energy in the flywheel is directly related with the voltage in the common bus. The principal advantage

¹In DBS schemes in DC distributed power systems, droop coefficient is typically a proportional gain that multiplies output inductor current of the converter. The resulting expression is then subtracted from the nominal voltage value to generate a voltage reference.

is the fact that dynamics of the system do not depend on changing SOC variable and the response can be explicitly designed. Description of the algorithm designed for control of clusters of flexible loads and its integration with this version of DBS method are elaborated in the next section.

III. DESCRIPTION OF THE LARGE-SCALE HEV AGGREGATION CHARGING ALGORITHM

The algorithm that was used in this paper was originally developed for large scale control of thermostatically regulated loads. Its adaptation to HEV chargers has first been proposed in [17]. The principal idea behind the concept is to allow slight real-time modifications of predefined charging algorithms in order to achieve certain effects when observing an aggregated behavior of the whole vehicle fleet.

To that end, it has been demonstrated in [17] that if HEVs have a real-time controllable dead-band around requested SOC propagation, they can effectively smooth out the total requested power from utility mains.

An especially favorable characteristic of this kind of algorithm is that it does not need information from the loads to perform its functionality. Instead, it only distributed one common signal to all the controllable loads. In that sense, an aggregated characteristic of all the chargers within the jurisdiction of one aggregator² behaves as a virtual power plant. The schematic representation of the kind of control achieved by means of aggregators which distribute common signals is shown in Fig. 2. The algorithm for one EV charging station (highlighted with red dashed line in Fig. 2) can be formulated as follows:

$$\Delta_+ = E(t) + (band + DSO(t)) \quad (1)$$

$$\Delta_- = E(t) - (band - DSO(t)) \quad (2)$$

with *band* being the allowable dead-band around the mean SOC, *DSO(t)* the real-time control signal from i.e. distribution system operator, and *E(t)* the total energy requested by the particular charger. Some ideas on how to generate the signal are presented in [17]. Here, we will assume this signal pre-calculated and focus our attention exclusively on internal control mechanism. The main problem of this particular algorithm in its basic form is very aggressive treatment of HEVs battery pack since the charging takes place in a bang-bang fashion. With respect recent research results made in predicting the ageing mechanisms of lithium-ion batteries, the most widely used storage technology used for HEVs, this kind of intermittent charging will in general cause their very fast degradation and compromise the economic viability of the algorithm. On the other hand, it should be noted that this adverse trait may be easily mitigated with dedicated energy storage system that is able to compensate for this fast changes power demand. For that purpose, this paper proposes a fully distributed balancing strategy which uses a FESS that not only allows representing a charging station as a bang-bang system

²Aggregator can be defined as a player who serves as intermediaries between the loads and a system operator. It could include third-party firms or load serving entities

TABLE I
REAL-TIME SIMULATION SETUP PARAMETERS

Parameter	Symbol	Value
Electrical parameter		
DC link capacitance	C_{DC}	2.2mF
HEV charger		
Charger current time constant	T_{HEV}	0.02s
Induction machine		
Flywheel inertia	J	0.8 kgm ²
Leakage factor	σ	0.556
Stator inductance	L_S	0.01160494 mH
Rotor inductance	L_R	0.01160494 mH
Stator resistance	R_S	1.945 Ω
Rotor resistance	R_R	2.3736 Ω
Nominal rotational speed	ω_{ref}	155 rad/s
Flywheel control		
Time constant of current loop	T_{fly}	0.00025s
Outer proportional term	kp_q	3
Outer integral term	ki_q	100
Nominal rotational speed	ω_{ref}	1500rpm
Droop gain	K_2	0.1

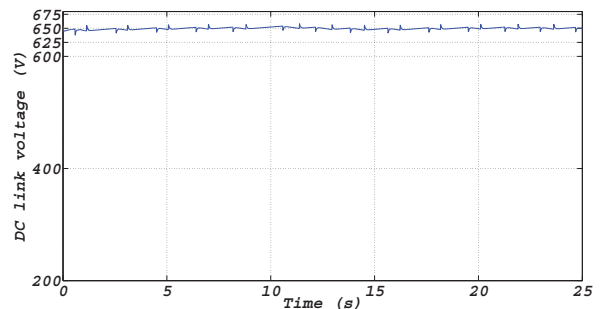

Fig. 4. DC link voltage.

from overhead power system perspective, but also avoids any impact of recommended HEV charging algorithm. The full control structure is shown in Fig. 3. System basically switches between the two states; nominal current extraction from the grid, and zero current extraction. With respect to signal, which represents real-time command from i.e. distribution system operator, the switching bounds can be shifted up and down. Noting that the speed, and hence the energy stored in flywheel, is linked to a common DC bus voltage, a slow PI voltage controller in outer loop of grid tied inverter will force the flywheel to always operate around its nominal speed. Therefore, quick power imbalances will be automatically be compensated by the flywheel and HEV charger will be able to execute its algorithm.

IV. REAL-TIME SIMULATION RESULTS

A model shown in Fig. 3 has been assembled in Matlab/Simulink and compiled to dSPACE 1103 for real time simulation run on sampling time of 10 kHz. Averaged model of flywheel converter has been used, whereas grid side converter has been simplified and represented as a controllable current source. Moreover, HEV charger was programmed to extract

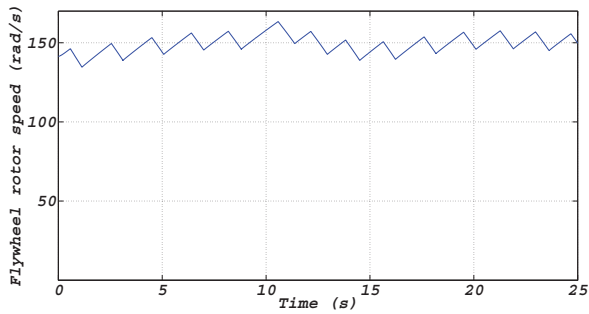

Fig. 5. Flywheel speed.

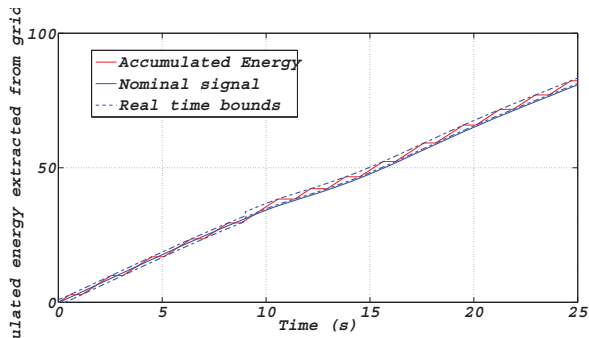

Fig. 6. Accumulated energy from the grid-side converter.

constant current from the DC link which is consistent with the first and the most significant stage in the typical two-stage charging algorithms proposed by battery manufacturers [20]. Induction machine was modeled in detail with corresponding parameters presented in Table I. These parameters represent the real machine from experimental setup configuration. The same table shows also the capacitance connected to a DC link and selected hysteresis band.

Standard vector control was used with inner current loops tuned for torque rise time around 2 ms. The parameters of inner and outer controllers are also represented in Table I. DC droop controller analyzed in detail in [8] was used as external control loop that helps coordinate the performance of grid side and flywheel converters. At the time of 9 sec, signal from distribution system operator changes from 0 to 1.5 and hence the boundary region is shifted upwards (see Fig. 6). This also causes low frequency oscillation of flywheel speed, as can be seen in Fig. 5 but due to slow outer PI voltage regulator, it again stabilizes around nominal speed.

Full propagation of the DC link voltage is depicted in Fig. 4. Maximum deviations from the common value of around 10 V can be observed which is acceptable value. However, it should be noted that one may expect bigger deviations in practical experimental setup mostly due to delays introduced by the digital control system. As already mentioned, grid side converter was modeled as a DC current source and its current injection is shown in Fig. 7. On the other hand, Fig. 8 shows two zoomed figures representing transients of the flywheel currents in falling and rising edge of hysteresis controller, respectively.

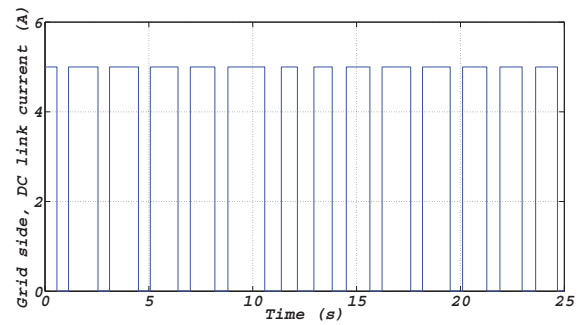
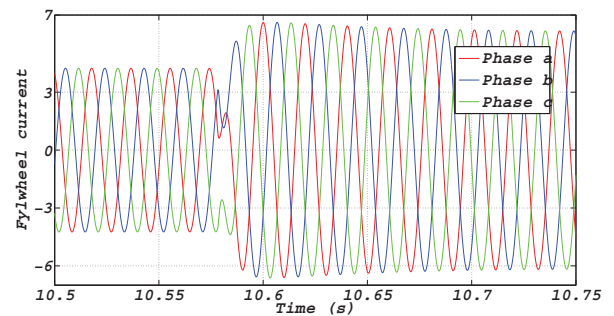
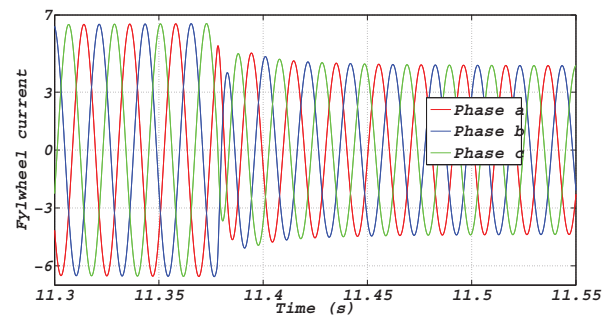

Fig. 7. Grid-side DC current.



(a) Transient of the flywheel current at the falling edge of hysteresis controller.



(b) Transient of the flywheel current at the rising edge of hysteresis controller.

Fig. 8. Flywheel current during hysteresis transients.

V. CONCLUSION

A local control strategy suitable for handling big number of HEV charging stations in future Smart Grid was presented in this paper. The work was inspired by the algorithms that were previously used for large scale coordination of thermostatically controlled loads. The specific characteristic of strategy designed in this paper is that it utilizes a dedicated ESS which enables provision of frequency regulation service to the grid, but does not compromise the predefined charging algorithm of HEV battery. In this particular case, flywheel based ESS was used and distributed bus signaling mechanism was used for internal coordination. The approach presented here is not limited to public fast charging stations but can be directly applied to all three charging levels. Real-time simulations were performed in order to demonstrate the effectiveness of proposed approach. Research that builds upon the results presented here is currently under way and includes implemen-

tation of the algorithm within the practical experimental setup with real converters and flywheel. In addition, authors are carrying out theoretical analysis of the stability of the overall control system which is essentially hybrid since the algorithm inherently switches between two linear time-invariant systems.

ACKNOWLEDGEMENT

The work of the authors is a part of the Flex-ChEV - Flexible Electric Vehicle Charging Infrastructure funded by SmartGrids ERA-Net under Energinet in the contract ForskEL-project nr. 2014-1-12156.

REFERENCES

- [1] R. Teodorescu, M. Liserre, and P. Rodriguez, *Grid Converters for Photovoltaic and Wind Power Syst.* Wiley, 2011.
- [2] G. Boyle, *Renewable Energy: Power for a Sustainable Future.* OUP Oxford, 2012.
- [3] A. Saber and G. Venayagamoorthy, "Plug-in vehicles and renewable energy sources for cost and emission reductions," *Ind. Electron., IEEE Trans. on*, vol. 58, no. 4, pp. 1229–1238, 2011.
- [4] A. Emadi, M. Ehsani, and J. M. Miller, *Vehicular Electric Power Syst.: Land, Sea, Air, and Space Vehicles.* The Power engineering, Taylor & Francis, 2010.
- [5] Z. Fan, "A Distributed Demand Response Algorithm and Its Application to PHEV Charging in Smart Grids," *Smart Grid, IEEE Trans. on*, vol. 3, no. 3, pp. 1280–1290, 2012.
- [6] A. Rautiainen, S. Repo, P. Jarventausta, A. Mutanen, K. Vuorilehto, and K. Jalkanen, "Statistical Charging Load Modeling of PHEVs in Electricity Distribution Networks Using National Travel Survey Data," *Smart Grid, IEEE Trans. on*, vol. 3, no. 4, pp. 1650–1659, 2012.
- [7] D. Steen, L. A. Tuan, O. Carlson, and L. Bertling, "Assessment of Electric Vehicle Charging Scenarios Based on Demographical Data," *Smart Grid, IEEE Trans. on*, vol. 3, no. 3, pp. 1457–1468, 2012.
- [8] T. Dragicevic, S. Sucic, J. C. Vasquez, and J. M. Guerrero, "Flywheel-Based Distributed Bus Signalling Strategy for the Public Fast Charging Station," vol. PP, no. Early Access, pp. 1–11, 2014.
- [9] H. Akagi and H. Sato, "Control and performance of a doubly-fed induction machine intended for a flywheel energy storage system," *Power Electron., IEEE Trans. on*, vol. 17, no. 1, pp. 109–116, 2002.
- [10] R. Cardenas, R. Pena, G. M. Asher, J. Clare, and R. Blasco-Gimenez, "Control strategies for power smoothing using a flywheel driven by a sensorless vector-controlled induction machine operating in a wide speed range," *Ind. Electron., IEEE Trans. on*, vol. 51, no. 3, pp. 603–614, 2004.
- [11] S. Samineni, B. K. Johnson, H. L. Hess, and J. D. Law, "Modeling and analysis of a flywheel energy storage system for Voltage sag correction," *Ind. Applications, IEEE Trans. on*, vol. 42, no. 1, pp. 42–52, 2006.
- [12] G. O. Cimuca, C. Saudemont, B. Robyns, and M. M. Radulescu, "Control and Performance Evaluation of a Flywheel Energy-Storage System Associated to a Variable-Speed Wind Generator," *Ind. Electron., IEEE Trans. on*, vol. 53, no. 4, pp. 1074–1085, 2006.
- [13] J. Schonberger, R. Duke, and S. D. Round, "DC-Bus Signaling: A Distributed Control Strategy for a Hybrid Renewable Nanogrid," *IEEE Trans. on Ind. Electron.*, vol. 53, no. 5, pp. 1453–1460, 2006.
- [14] K. Sun, L. Zhang, Y. Xing, and J. M. Guerrero, "A Distributed Control Strategy Based on DC Bus Signaling for Modular Photovoltaic Generation Systems With Battery Energy Storage," *IEEE Trans. on Power Electron.*, vol. 26, no. 10, pp. 3032–3045, 2011.
- [15] T. Dragicevic, J. M. Guerrero, J. C. Vasquez, and D. Skrlec, "Supervisory Control of an Adaptive-Droop Regulated DC Microgrid With Battery Management Capability," *Power Electron., IEEE Trans. on*, vol. 29, no. 2, pp. 695–706, 2014.
- [16] T. Dragicevic, Q. Shafiee, D. Wu, L. Meng, J. Vasquez, and J. Guerrero, "Modeling and control of flexible hev charging station upgraded with flywheel energy storage," in *Multi-Conference on Systems, Signals Devices (SSD), 2014 11th International*, pp. 1–7, Feb 2014.
- [17] D. S. Callaway and I. A. Hiskens, "Achieving Controllability of Electric Loads," *Proceedings of the IEEE*, vol. 99, no. 1, pp. 184–199, 2011.
- [18] R. Cardenas, R. Pena, G. Asher, and J. Clare, "Control strategies for enhanced power smoothing in wind energy systems using a flywheel driven by a vector-controlled induction machine," *Industrial Electronics, IEEE Transactions on*, vol. 48, pp. 625–635, Jun 2001.
- [19] X. Lu, J. M. Guerrero, K. Sun, and J. C. Vasquez, "An Improved Droop Control Method for DC Microgrids Based on Low Bandwidth Communication With DC Bus Voltage Restoration and Enhanced Current Sharing Accuracy," *IEEE Trans. on Power Electron.*, vol. 29, no. 4, pp. 1800–1812, 2014.
- [20] D. Linden and T. B. Reddy, *Handbook of Batteries.* McGraw-Hill, 2002.