



**AALBORG UNIVERSITY**  
DENMARK

**Aalborg Universitet**

## **Power electronics - The key technology for Renewable Energy Systems**

Blaabjerg, Frede; Ma, Ke; Yang, Yongheng

*Published in:*

Proceedings of the 9th International Conference on Ecological Vehicles and Renewable Energies, EVER 2014

*DOI (link to publication from Publisher):*

[10.1109/EVER.2014.6844159](https://doi.org/10.1109/EVER.2014.6844159)

*Publication date:*

2014

*Document Version*

Early version, also known as pre-print

[Link to publication from Aalborg University](#)

*Citation for published version (APA):*

Blaabjerg, F., Ma, K., & Yang, Y. (2014). Power electronics - The key technology for Renewable Energy Systems. In Proceedings of the 9th International Conference on Ecological Vehicles and Renewable Energies, EVER 2014 IEEE Press. DOI: 10.1109/EVER.2014.6844159

### **General rights**

Copyright and moral rights for the publications made accessible in the public portal are retained by the authors and/or other copyright owners and it is a condition of accessing publications that users recognise and abide by the legal requirements associated with these rights.

- ? Users may download and print one copy of any publication from the public portal for the purpose of private study or research.
- ? You may not further distribute the material or use it for any profit-making activity or commercial gain
- ? You may freely distribute the URL identifying the publication in the public portal ?

### **Take down policy**

If you believe that this document breaches copyright please contact us at [vbn@aub.aau.dk](mailto:vbn@aub.aau.dk) providing details, and we will remove access to the work immediately and investigate your claim.

# Power Electronics – The Key Technology for Renewable Energy Systems

Frede Blaabjerg, Ke Ma, Yongheng Yang  
 Department of Energy Technology, Aalborg University  
 Pontoppidanstraede 101  
 DK-9220 Aalborg, Denmark  
 Email: [fbl@et.aau.dk](mailto:fbl@et.aau.dk), [kema@et.aau.dk](mailto:kema@et.aau.dk), [yoy@et.aau.dk](mailto:yoy@et.aau.dk)

**Abstract**— The energy paradigms in many countries (e.g. Germany and Denmark) have experienced a significant change from fossil-based resources to clean renewables (e.g. wind turbines and photovoltaics) in the past few decades. The scenario of highly penetrated renewables is going to be further enhanced – Denmark expects to be 100 % fossil-free by 2050. Consequently, it is required that the production, distribution and use of the energy should be as technologically efficient as possible and incentives to save energy at the end-user should also be strengthened. In order to realize the transition smoothly and effectively, energy conversion systems, currently based on power electronics technology, will again play an essential role in this energy paradigm shift. Using highly efficient power electronics in power generation, power transmission/distribution and end-user application, together with advanced control solutions, can pave the way for renewable energies. In light of this, some of the most emerging renewable energies, e.g. wind energy and photovoltaic, which by means of power electronics are changing character as a major part in the electricity generation, are explored in this paper. Issues like technology development, implementation, power converter technologies, control of the systems, and synchronization are addressed. Special focuses are paid on the future trends in power electronics for those systems like how to lower the cost of energy and to develop emerging power devices and better reliability tool.

**Keywords**— *power electronics; renewable energy systems; photovoltaic systems; wind turbine systems; reliability; advanced control; ancillary services.*

## I. INTRODUCTION

An increasing demand of efficient and environmentally friendly electricity generation from Renewable Energy Systems (RESs) has been one of the main drivers of the continuously booming RES installation, which is going to be tripled within the next few decades [1]-[4]. As a consequence, much more great efforts have been made by many countries (e.g. Germany, Spain, and Denmark) to further introduce renewable energies, such as wind power, PhotoVoltaic (PV) power, hydropower and biomass power

Main part of this paper has been presented at the 8<sup>th</sup> *International Conference on Integrated Power Electronics Systems, CIPS 2014*, Feb. 25-27, 2014, Nuremburg, Germany.

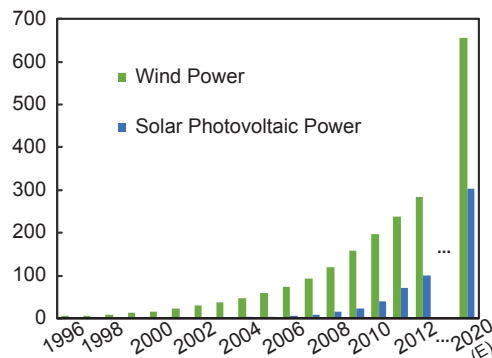

Fig. 1: Global cumulated wind power and solar PV capacity (Giga-watts) from 1996 to 2012, and an Estimation (E) by 2020 [1], [2].

into the public grid. As it is shown in Fig. 1, among various renewable energies, Wind Turbine System (WTS) and PV system technologies have become the most promising technologies, accounting for a large share of renewable energy generation [4]-[14]. However, an even wide-scale adoption of RESs poses two major challenges, which are in urgent need to be coped with. One is the shift of power production from the conventional and fossil-based energy sources to renewable energy resources. The other one is the use of power electronics in the power generation, the power transmission/distribution and the end-user application involved in the RESs.

Power electronics technology should be of high efficiency and exceeding reliability, since it has been the key to the energy conversion from the most emerging renewable energy sources, e.g. WTS and PV systems. Thus, it should be able to transfer the renewable energies to the grid, and also capable to exhibit advanced ancillary functions (e.g. Low Voltage Ride-Through, LVRT and grid support with reactive power injection). A wide-scale adoption of power electronics technology makes those completely environmentally dependent energies more controllable, but increasingly intricate. Enabled by intelligent control strategies, the power electronics technology can fulfill the requirements imposed by the distribution/transmission system operators as well as specific demands from the end-customers, especially when much more advancements of power devices, system monitoring and data processing technologies are achieved.

In this paper, as the enabling technology of a clean and reliable power conversion from WTSs and PV systems, the status and the future trends in power electronics technology are explored. In § II, the demands of RESs are presented, followed by the WTS and PV technologies, including main power converter topologies and a review of power device development in RESs. Then, typical control strategies for PV systems and wind turbines are given in § IV when considering the grid demands. Focuses are paid on the future trends in power electronics, which are discussed in § V, associated by case studies.

## II. DEMANDS OF RENEWABLE ENERGY SYSTEMS

A demonstrative and simplified architecture of modern RES based power generation systems is shown in Fig. 2, where the power electronics unit is the key component. Objectives of those systems are to manage the power demanding from the local operators as well as the end-customers [4], [5]. A very common requirement of a RES is to transfer the renewable energy to the grid, according to its inherent characteristics. Other specific demands can be summarized as: a) reliable/secure power supply, b) high efficiency, low cost, small volume, and effective protection, c) control of active and reactive power injected into the grid, d) dynamic grid support (ride-through operation), and e) system monitoring and communication.

### A. Demands in Wind Turbine Systems

In WTSs, the current flowing in the generator rotor or stator should be regulated to control the electromagnetic torque, not only for maximizing the extracted power from the wind turbines, but also for the energy balancing in case of dynamics due to inertia mismatch between mechanical and electrical power. As for the grid side, the converter must emulate the behaviors of conventional power plants regardless of the wind speed. This means it should help to maintain the frequency as well as voltage amplitude of the grid (e.g. the voltage at the Point of Common Coupling, PCC), and also withstand the grid faults or even make a contribution to the grid faults recovery by means of reactive current injection as shown in Fig. 2 [2], [16], [17].

Owing to relative large power capacity, the failures of the power conversion systems will strongly violate the grid stability, and thus result in additional cost for repairing; thereby the reliability performance is specially emphasized in modern WTSs. Moreover, because of high power capacity, the voltage level of the generator may have to be boosted up to facilitate the power transmission, and thus a transformer is normally required. Furthermore, due to the limited space in the nacelle or tower of a wind turbine, power density and cooling ability are crucial for wind power conversion systems. In addition, energy storage systems to balance the mismatch power between the turbine and grid is an important issue, and may lead to extra cost of the system.

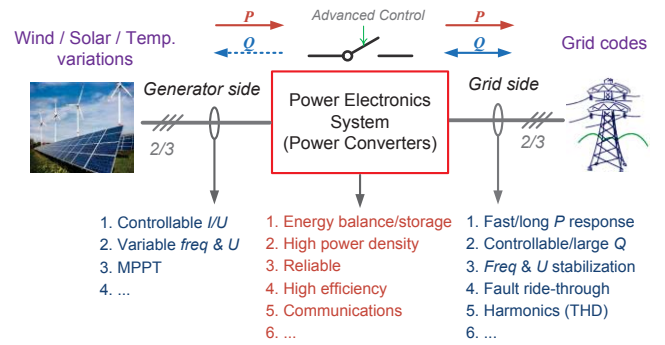

Fig. 2: Demands for renewable energy systems when integrated into the power grid.

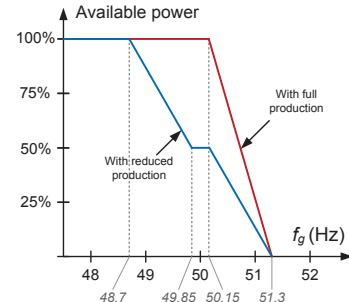

Fig. 3: Frequency control profiles through active power control for the wind turbines connected to the Danish grid [21].

### B. Demands from the Grid Side

Most countries have stringent requirements to guide the behavior of WTSs, known as “grid codes” which are updated regularly [18]-[22]. The grid codes are basically trying to make the WTS to act as a conventional power plant from the electrical utility point of view. It means that, instead of only a passive power source simply injecting available power from the wind, the WTS also has to behave like an active generation unit, which can flexibly control the power according to demands, and also provide grid supports if necessary. The following show examples of the state-of-the-art grid requirements, specified either for individual wind turbine or for the whole wind farm.

It is required in most grid codes (e.g. in Denmark, Ireland and Germany) that an individual wind turbine has to control the active power at the PCC, which is regulated based on the grid frequency to maintain a stable grid. The characteristic of frequency control through active power regulation in the Danish grid codes is exemplified as Fig. 3, which shows that the active power should be decreased when the frequency rises above 48.7 Hz or 50.15 Hz depending on the power reserving strategy [21]. Similarly, the reactive power delivered by the WTS has also to be regulated within a certain range, as shown in Fig. 4. Both the Danish and German grid codes give a range of the reactive power delivered by the WTS to the active power output [22]- this will lead to larger MVA capacity when designing the whole converter system. Meanwhile, the Transmission System Operator (TSO) will normally specify the reactive power range of the wind turbine system

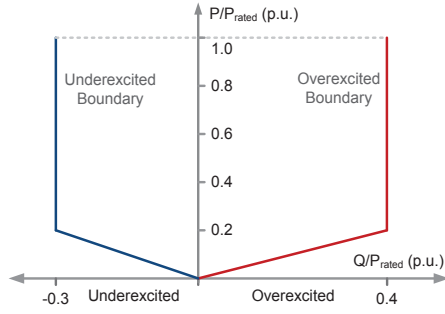

Fig. 4: Reactive power ranges under different generating powers for a wind farm specified by the German grid codes [22].

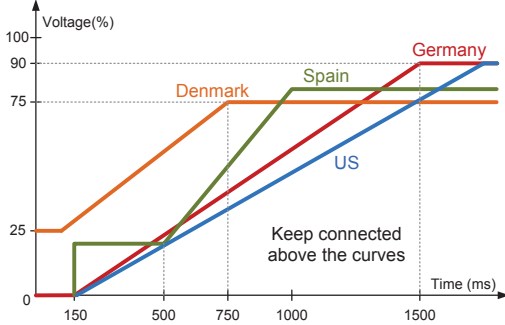

Fig. 5: Voltage profiles for wind turbines with low voltage ride-through capability in different countries.

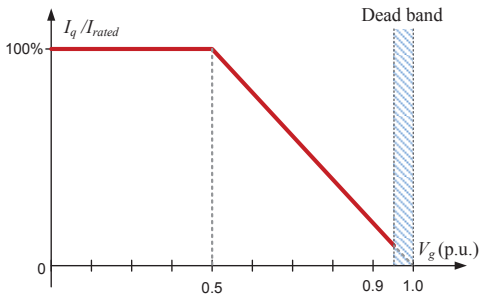

Fig. 6: Reactive current requirements for WTSs during LVRT by the German and Danish grid codes [21], [22].

according to the grid voltage levels. It is noted that this reactive power control should be realized slowly under the time constant of minutes in steady state operation [18].

Besides the grid requirements in the normal operation, the TSOs have also issued strict grid support requirements for WTSs under grid faults. As shown in Fig. 5, the stay-connected durations are defined for WTSs in response to grid voltage sags. Meanwhile, WTSs should also provide reactive power (up to 100% current capacity) for grid voltage recovery during LVRT. Fig. 6 shows an example of the required amount of reactive current under grid faults defined in the German [22] and Danish grid codes [21]. This demand is relatively difficult to achieve by some wind turbine concepts, and other power quality units like STATCOMs may probably be introduced to help the WTS to ride-through voltage sags.

More grid supports by WTSs have not only increased the cost per produced kWh, but also made the wind energy more suitable to be largely utilized and integrated into the

power grid. It can be predicted that the stricter grid codes in the future will keep challenging the WTSs, and thus pushing forward the power electronic technologies.

### C. Demands in PV Systems

Grid-connected PV systems are being developed very fast and will soon take a major part of electricity generation in some areas [23], [24]. Thus, the PV systems have to comply with much tougher requirements than ever before. These demands can be generally categorized into three parts- the PV side, the power conversion system, and the grid-side, as shown in Fig. 2. Yet, the power capacity of a PV system (e.g. residential application, several kW) is not as large as that of an individual WTS (e.g. several MW). Moreover, the power inertia of PV output is compatible with the grid behavior, and thus the demands are of less stringency when compared to WTSs.

For the PV side, the current or voltage of the PV panels should be controlled to extract the solar energy. Thus, a DC-DC converter is commonly used in PV systems to flexibly track the maximum power, strongly depending on the mission profiles (e.g. solar irradiance level and ambient temperature). In this case, the DC voltage should be maintained as a desirable value for the inverter. For the grid side, normally the Total Harmonic Distortion (THD) of the output current has to be restrained at a lower level (e.g. 5%) [4]. While for large PV systems with higher power ratings (e.g. hundreds of kW), the grid side also demands the PV inverter to stabilize the grid voltage by providing ancillary services. In response to the grid faults, the PV inverters have to ride-through voltage faults, when a higher PV penetration level comes into reality [25]-[32]. Thus, the PV systems have to comply with the grid requirements similar with those for WTSs, as shown in Figs. 5 and 6. Such grid requirements are undergoing an extension to cover a wide range of PV applications, even PV modules and small PV systems [28], [29].

As the power capacity per generating unit is relative low but the cost of energy is relative high, and thus there are strong demands for high efficiency in order to achieve acceptable price per produced kWh in PV systems. The transformerless PV inverters with further extended conversion efficiency have gained increasing popularity in the European market (e.g. Germany and Spain) [4], [7]. However, in this case the safety becomes more crucial because of the lack of galvanic isolation in transformerless PV systems. Reduction of the potential leakage current is generally required [7]. Furthermore, similar to the WTSs, reliability is important for power electronics based PV systems, and motivated by extending the total energy production (service time) and reducing the cost of energy. Finally, because of exposure or smaller housing chamber, the PV converter system must be more temperature insensitive, which is also beneficial for the reliability performance.

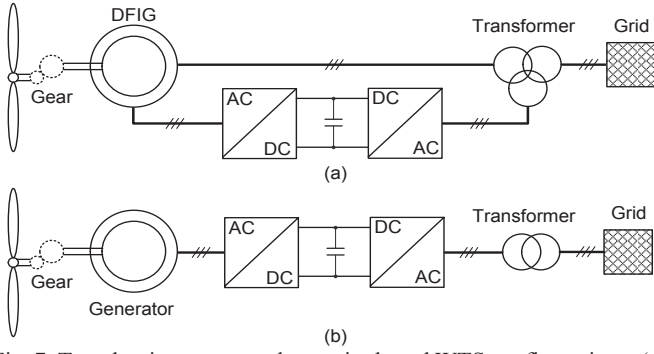

Fig. 7: Two dominant power electronics based WTS configurations: (a) partial-scale back-to-back power converter based wind turbine system and (b) full-scale back-to-back power converter based wind turbine system.

### III. POWER CONVERTER TOPOLOGIES AND DEVICES FOR RENEWABLE ENERGY APPLICATIONS

Design and operation of power electronics converters for both WTSs and PV systems are of strong reliance on the grid requirements and the energy demand. It can be seen from the evolution of wind turbine power converters, which has changed from non-power-electronics-based topologies to full-scale power converters with increasing power ratings of individual wind turbine (tens of kW to several MW) [4], [8]-[10], [12]. As the demand of higher power ratings and efficiency increases for PV systems, the PV power converters also evolved a significant change, being mostly transformerless nowadays [4], [6], [7].

#### A. Wind Turbine Concepts

For WTSs, the most commonly used design concepts can be categorized into four types: 1) fixed speed wind turbine systems, 2) partial variable speed wind turbine with variable rotor resistance, 3) variable speed wind turbine with partial-scale frequency converter, and 4) variable speed wind turbine with full-scale power converter. Among those WTS configurations, the latter two types as shown in Fig. 7 are currently dominant in the markets. Moreover, the two concepts are expected to be even more widely adopted in the future.

As it has been demonstrated in Fig. 7, the power electronics technology still plays an essential role in those two concepts. Regarding the power converter topologies for wind power applications, the most commonly adopted three-phase converter is the two-level Voltage Source Converter (2L-VSC) of simple structure and few components, as shown in Fig. 8. However, since the power capacity of an individual wind turbine keeps growing up to even 10 MW [13], [14], the 2L-VSC is not very feasible due to lower efficiency. In view of this, the multi-level converter technology, which can achieve more output voltage levels, higher voltage and larger output power, gains much more popularity in the wind turbine applications [9], [10], [13]-[16].

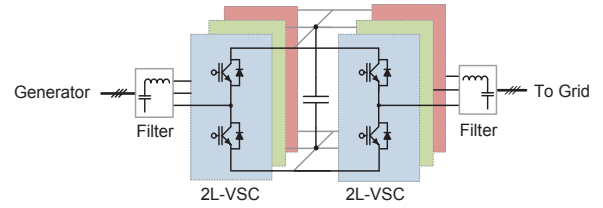

Fig. 8: 2L-VSC Back-to-Back (2L-VSC BTB) converter for WTSs.

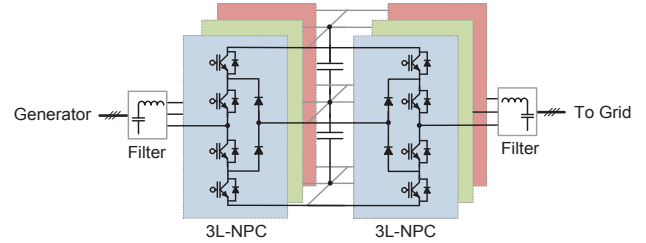

Fig. 9: 3L-NPC Back-to-Back (3L-NPC BTB) converter for WTSs.

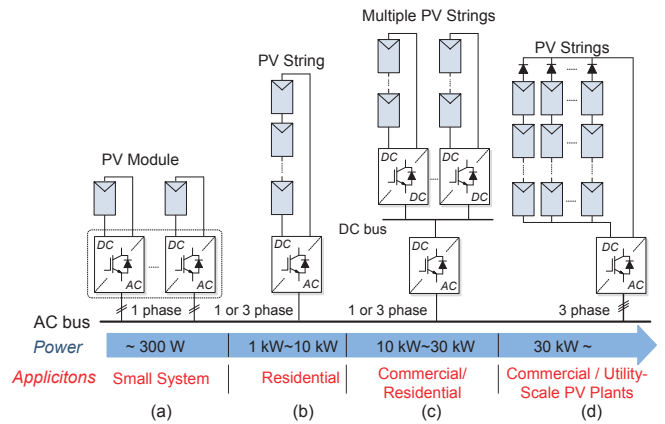

Fig. 10: Grid-connected PV systems with: (a) module inverter, (b) string inverter, (c) multi-string inverter, and (d) central inverter [6].

The most commercialized multi-level converter is the three-level Neutral Point diode Clamped (3L-NPC) topology shown in Fig. 9. Compared to the 2L-VSC, 3L-NPC can achieve one more output voltage level, thus leading to a smaller filter. The major drawback of this converter is the unequal loss distribution between the inner and outer switching devices, which may contribute to a de-rated converter power capacity [14], [15]. To solve this problem, multi-cell converter topologies (i.e. parallel/ series connection of converter cells) are developed and widely adopted by the industries (e.g. Gamesa and Siemens) [17], [34].

#### B. PV System Configurations

A general classification of grid-connected PV inverters is shown in Fig. 10. A common central inverter can be used in a PV plant larger than tens of kWp with higher efficiency and lower cost. Its major disadvantages are high voltage DC cables, common Maximum Power Point Tracking (MPPT) and module mismatch [6]. Compared to central inverters, the string inverter can achieve MPPT separately, leading to a better total energy yield. However, there are mismatches in the PV panels connected in series.

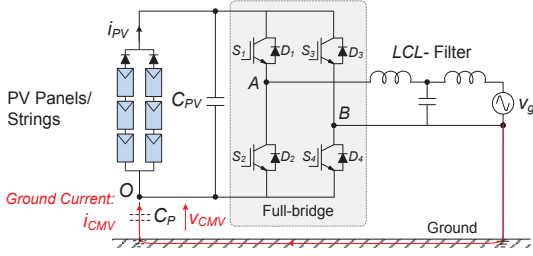

Fig. 11: Single-phase full-bridge PV inverter with an *LCL*-filter.

Thus, the module inverter is developed, which acts on a single PV panel with an individual MPPT. The main disadvantage of a module inverter is the low overall efficiency. Another PV technology is an intermediate solution between the string inverter and the module inverter, being a multi-string inverter. This configuration is flexible with a high overall efficiency because each PV string is controlled separately.

In contrast to WTSs, the PV systems of much lower power ratings, as shown in Fig. 10. Thus, at present, single-phase topologies are more common for the PV applications. In those cases, DC/DC converters are adopted to boost up the PV voltage within an acceptable range of the PV inverter. Boost converters also offer the flexibility of MPPT control. However, several PV power plants have come into service recently using central inverters (e.g. SMA Sunny Central CP XT inverter [35]) and more are under construction, due to an intense energy demand and carbon dioxide emission reduction. The power converter technology for this is similar to the grid side converter technology in WTSs.

When it comes to the design of PV inverters as well as their related control methods, the efficiency and leakage current are two main considerations. A widely adopted single-phase PV inverter is the Full-Bridge (FB) topology as shown in Fig. 11, where a bipolar modulation is more feasible in the light of safety issues. However, the conversion efficiency is not very satisfying. Due to higher efficiency, transformerless PV inverters [4], [6], [7], [36]-[42] by considering the leakage current issue have gained much more popularity especially in the European markets. For instance, the H6 inverter patented by Ingeteam [37] shown in Fig. 12(a) disconnects the PV panels/strings from the inverter using four extra devices to realize the “isolation”; while the Highly Efficient and Reliable Inverter Concept (HERIC inverter) by Sunways [39] provides an AC bypass, as shown in Fig. 12(b). There have been other topologies reported in the literature, [7], [40]-[42]. An example shown in Fig. 13 is based on the Neutral Point Clamped (NPC) technology.

Although single-phase configurations are more common for low power rating PV applications, some companies like SMA, Sunways, Kaco, and Danfoss are

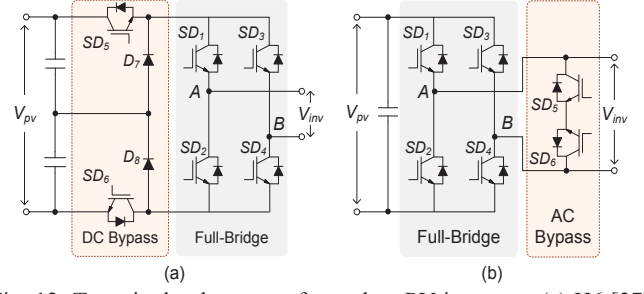

Fig. 12: Two single-phase transformerless PV inverters: (a) H6 [37] and (b) HERIC [39].

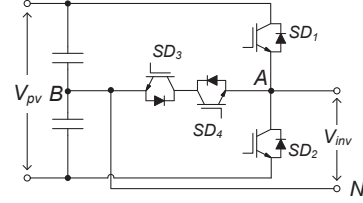

Fig. 13: NPC transformerless topology for PV applications.

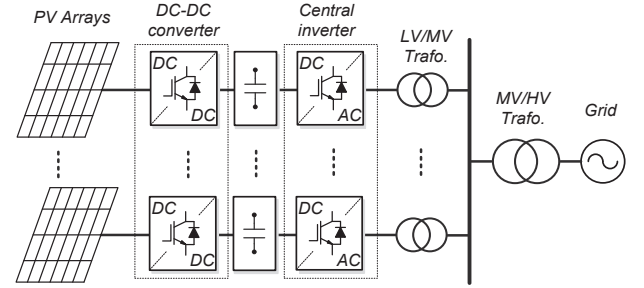

Fig. 14: Typical large-scale PV power plant based on central inverters for utility applications.

also promoting the three-phase PV systems with central inverters for utility-scale applications [35], [43], [44]. Those large PV power plants, rated over tens and even hundreds of MW, adopt many central inverters with the power rating of up to 900 kW. A typical large-scale PV power plant is shown in Fig. 14, in which DC-DC converters are also used before the central inverters. Notably, for high power rating PV applications, NPC technologies might be a promising solution to the realization of large-scale PV systems.

### C. Power Devices for WTS and PV Systems

Power semiconductors are the backbone in the power electronics technology, and they have significant impacts on the performances of the RESs, e.g. cost, efficiency, reliability, and modularity. The potential silicon based semiconductor technologies in the wind power application are among the module packaged *Insulated Gate Bipolar Transistor* (IGBT), press-pack packaged IGBT and the press-pack packaging *Integrated Gate Commutated Thyristor* (IGCT) [45]-[49]. In contrast, the module packaged IGBT and *Metal Oxide Semiconductor Field Effect Transistor* (MOSFET) are widely witnessed in the PV applications.

Moreover, the advancements of Silicon Carbide (SiC) based devices have also shown much potential to wind turbine applications, although currently the SiC devices are mainly in the form of MOSFET as well as diodes and targeted for low power applications, e.g. PV systems. In addition, the Gallium Nitride (GaN) based power device has been another emerging device, and drawn much attention recently. With the advantages of higher switching speed and further compacted power density, GaN devices are much suitable for PV applications.

Different types of power semiconductor devices have quite different characteristics and a benchmarking of four devices is given in Table I. It can be observed in Table I that the module packaging technology of IGBT has a longer track-record and fewer mounting regulations. However, due to the soldering and bond-wire connection of internal chips, module packaging devices may suffer from larger thermal resistances, lower power density and higher failure rates [48]. Improvements of the packaging technology of IGBT modules can be achieved by introducing pressure contact to eliminate the base-plate, and thus base-plate soldering, using sinter technology to avoid the chip soldering, and replacing bond wire material for reduced coefficient of thermal expansion. All those solutions can contribute to increased lifetime of module packaging IGBTs as reported in [49].

Press-pack packaging technology can improve the connection of chips by direct press-pack contacting, which leads to improved reliability, higher power density (easier stacking for series connection) and better cooling capability. Press-pack IGCTs were first introduced into the medium-voltage motor drives back to 1990's and has already become the state-of-the-art technology for applications of oil, gas, High Voltage DC Transmission Systems (HVDC), power quality, etc. However, IGCTs have not yet been widely adopted in WTSS. As the power capacity of a single wind turbine grows even up to 10 MW, it can be expected that the press-pack packaging devices will become more promising for future WTSS. Nevertheless, the total cost of the systems is one determining factor in this technology shift.

Besides the silicon power devices, the SiC based devices, which are claimed to have better switching characteristics and lower power losses, are also promising in the future wind power systems. Although the existing power capacity of SiC devices are still not enough for wind power applications, these new device technologies show great potential for some of the future wind converter structures, which consist of paralleled/cascaded converter cells, where the requirements for voltage and current ratings are much lower. However, the main challenges for SiC based devices are the bonding technology, limitation of stray inductance either in the

external circuit or inside the module, higher  $dv/dt$  stress, higher operational temperature, as well as thinner chips – all have to be carefully taken into account in the packaging and design of SiC based converter systems.

TABLE I: BENCHMARKING OF POWER SEMICONDUCTOR DEVICES FOR WIND POWER APPLICATIONS.

	<i>IGBT module</i>	<i>IGBT Press-pack</i>	<i>IGCT Press-pack</i>	<i>SiC MOSFET module</i>
<b>Power Density</b>	Low	High	High	Low
<b>Reliability</b>	Moderate	High	High	Unknown
<b>Cost</b>	Moderate	High	High	High
<b>Failure mode</b>	Open circuit	Short circuit	Short circuit	Open circuit
<b>Easy maintenance</b>	+	-	-	+
<b>Insulation of heat sink</b>	+	-	-	+
<b>Snubber requirement</b>	-	-	+	-
<b>Thermal resistance</b>	Large	Small	Small	Moderate
<b>Switching loss</b>	Low	Moderate	Moderate	Low
<b>Conduction loss</b>	Moderate	Moderate	Moderate	Large
<b>Gate driver</b>	Moderate	Moderate	Large	Small
<b>Major manufacturers</b>	Infineon, Semikron, Mitsubishi, ABB, Fuji	Westcode, ABB	ABB	Cree, Rohm, Mitsubishi
<b>Medium voltage ratings</b>	3.3 kV / 4.5 kV / 6.5 kV	2.5 kV / 4.5 kV	4.5 kV / 6.5 kV / 10 kV	1.2 kV / 10 kV
<b>Max. current ratings</b>	1.5 kV / 1.2 kA / 750 A	2.3 kA / 2.4 kA	3.6 kA / 3.8 kA / 2 kA	180 A / 120 A

#### IV. CONTROL OF RENEWABLE ENERGY SYSTEMS

The first priority of the RES control is to extract as much energy as possible for the renewable energies in normal operation, also known as MPPT control. Besides, many specific grid requirements have been imposed on the RESs, which demand those system to better provide ancillary services [4], [5], [10], [29], [50]-[53], e.g. LVRT, reactive power control and frequency control through active power control, in order to ensure a reliable and efficient power generation.

It can be observed that the Distribution/Transmission System Operators (DSO/TSO) have devoted much more efforts to guarantee a stable operation of RESs and thus accept more renewable energies in the grid. This concern makes the control systems of RESs multi-functional, as shown in Fig. 15. There are basic controls like current regulation, DC bus stabilization and synchronization, which have to be quickly performed by the power converter typically using Proportional-Integral (PI) controllers or Proportional-Resonant (PR) controllers [5].

Some advanced control functions of RESs, e.g. riding through operation of the grid faults and providing grid-support functions, are needed for both WTSS and PV systems as shown in Fig. 15. In the variable speed wind turbine concept, the current in the generator will typically be changed by controlling the generator side converter, and thereby the rotational speed of turbine can be adjusted to achieve maximum power production based on the available wind power. In respect to operation under grid fault, coordinated control of several subsystems in the wind turbine such as the generator/grid side converters, braking chopper/crowbar and pitch angle controller, is necessary in order to handle the situation properly.

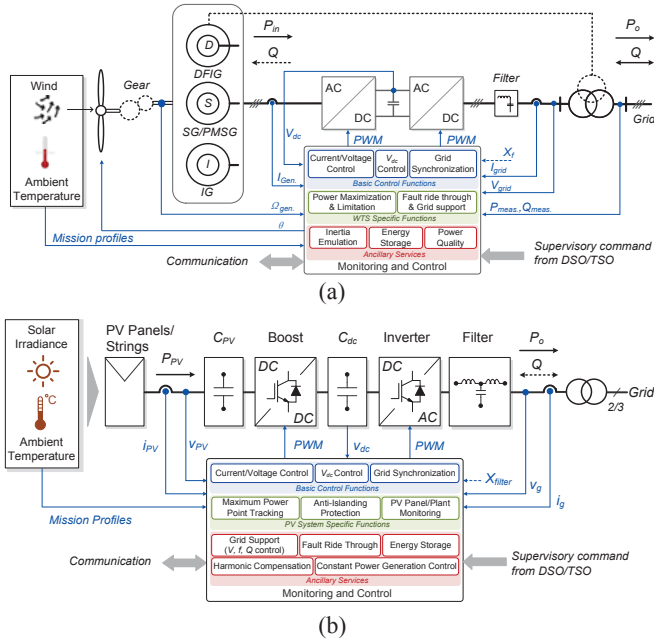

Fig. 15: General control function blocks for (a) wind turbine systems and (b) PV systems with a DC/DC boost stage.

In respect to the reactive power injection during LVRT operation in WTS applications, there are at least four major strategies [4], [5], [25]-[27], [52]: 1) unity power factor control, 2) positive and negative sequence control, 3) constant active power control and 4) constant reactive power control. Unbalanced grid faults are one of the most observed faults in three-phase systems. Due to an interaction between voltage sequences and current sequences under grid faults, either the controlled active power or reactive power will give oscillations.

As the PV systems are still at residential level in respect to single-phase systems, there are less control freedom (grid voltage and grid current) under grid faults. Typically, they are required to cease energizing local loads under grid faults, known as anti-islanding protection. However, the penetration level increases the necessity of LVRT with reactive power injection [28]-[31]. By considering the over-current protection of PV inverters and the reactive current injection requirements under grid faults, possibilities for reactive power injection of single-phase PV systems can be [32], [33]: 1) constant peak current strategy, 2) constant average active power strategy, 3) constant active current strategy, and 4) thermal optimized strategy. As for the three-phase PV systems, the control under grid faults is similar to that of the grid side converter in a wind power system, and thus the above strategies can be adopted and implemented in different reference frames [4], [5].

The injected current into the grid has to be synchronized well with the grid voltage, as standards require that in the field [4]-[6]. Therefore, the grid

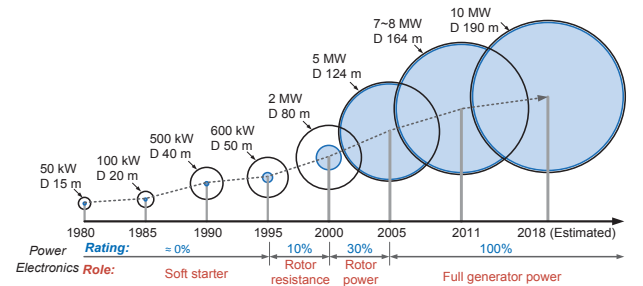

Fig. 16: Evolution of wind turbine size and the power electronics seen from 1980 to 2018 (Estimated), where the blue circle indicates the power coverage by power electronics.

synchronization issue plays an important role for both WTSs and PV systems. To address this problem, Phase Locked Loop (PLL) based synchronization methods stand out of various reported solutions [5]. Evaluating criterions for the synchronization methods are the dynamic response speed and the disturbance rejection capability. The Second Order Generalized Integrator based PLL (SOGI-PLL) presents a better performance compared to other methods, especially for single-phase systems [4], [5]. It can be a good candidate for the synchronization for RESs.

## V. FUTURE TRENDS IN POWER ELECTRONICS FOR RESs

As the heart of every renewable energy generation system, the power electronics converter is responsible for the efficient and reliable power generation. Thus, to realize a widespread adoption of such renewables, the power electronics technology will be more active into the grid in the future. With advanced control strategies, it can fulfill the upcoming stringent requirements regarding the efficiency, the controllability, the cost and the reliability.

### A. More Power Electronics

In the last few decades, the power electronics technology has become more and more advanced and brought significant improvements for the renewable energy generation [8]-[10], [54]-[56]. Together with intelligent control strategies, modern power electronics technology makes RESs more controllable and as active as the conventional power plants. There will more advanced power electronics systems in the future RESs to enable a better and flexible integration with the grid.

For instance, it can be seen from the evolution of the wind turbine technology in Fig. 16 that the power electronics converter has already achieved 100 % power coverage in the wind turbine system since 2005, while the PV systems have already been complete power-electronics-based systems. Fully power-electronics-based wind turbine technology will be further enhanced by advanced control strategies. Actually, in most of the newly established WTSs, power electronics converters have become essential components carrying all of the generated power up to multi-MW [5]-[9].



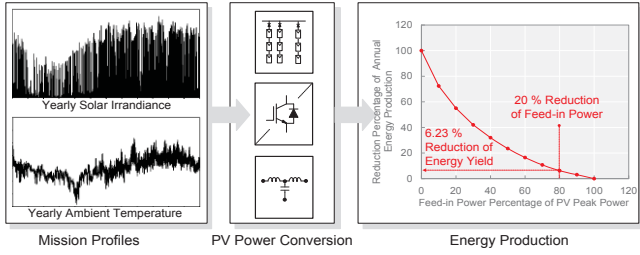

Fig. 17: Energy reduction due to the limitation of maximum feed-in power from PV systems.

### B. More Stringent Grid Requirements

In order to accept more renewables in the grid, the conventional power grid, which is normally based on centralized and large power plants, have to be modified to be more distributed and smaller generation units. Thus, new demands for grid integration standards, communication, power flow control, and protection are needed [10]-[12], [29]. Power electronic converters together with dedicated and intelligent control strategies again play an important role in this technology transformation.

Taking PV systems as an example, typically, MPPT is required during the operation. Recent studies [57] have showed that a limitation of the maximum feed-in power from PV systems only contributes to a limited energy reduction, as shown in Fig. 17. Thus, it is reasonable to avoid upgrading power infrastructure by limiting the maximum feed-in power from PV systems, which may also affect the entire system reliability. This requirement has been included in the German grid demands at a very high penetration level. The same philosophy may be imposed on other renewables (e.g. fuel-cell system). In that case, the control of power electronics should be ready.

### C. Lower Cost of Energy

Reducing the cost of energy is one of the most important considerations for a higher penetration of the installed capacity. Generally, a Levelized Cost of Energy (LCOE) index is adopted for qualification and comparison [58]-[60], and it can be expressed as:

$$LCOE = \frac{C_{Dev} + C_{Cap} + C_{O\&M}}{E_{Annual}} \quad (1)$$

in which  $C_{Dev}$  is the initial development cost,  $C_{cap}$  represents the capital cost,  $C_{O\&M}$  denotes the cost for operation and maintenance, and  $E_{Annual}$  is the average annual energy production in the whole lifetime. It is shown in (1) that the possibilities to lower the cost of energy are: a) to reduce the cost for development, capital, operation and maintenance and b) to extend the energy production or increase the lifetime of the generation system.

As it is shown in Fig. 18, the onshore wind power technology is currently competitive with the fossil-based power generation in terms of cost, while offshore wind power and solar PV technologies are still more expensive than the onshore wind power. The cost advantage is the

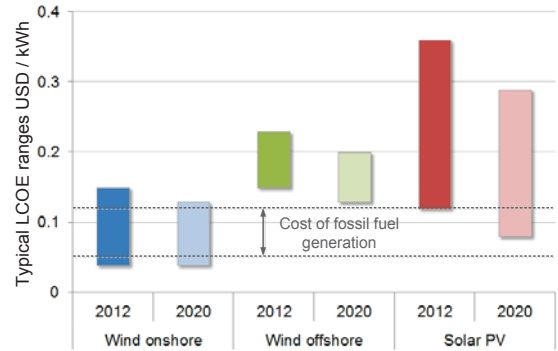

Fig. 18: Estimated LCOE for several renewable energy technologies for entering service in 2018 [59].

main contribution to the significant adoption of onshore wind power systems in the past few decades. As indicated in Fig. 18, there is great potential to further reduce the cost of offshore wind and solar PV technologies in the future. Since the power electronics technology is the key technology for RESs with higher power ratings, special cost considerations should also be taken into account for the design and control of power electronics converters.

### D. High Efficiency and High Reliability

Achieving high efficiency and high reliability are always of intense interest in order to further lower the cost of energy, and it will be strengthened in the future RESs. Improvements of efficiency can be achieved by integrating more power electronics systems with intelligent control strategies and developing more advanced power electronics devices (e.g. SiC-based modules). As the devices and components that comprise the power electronics system in a RES, the behavior of the power electronics devices will impose constraints on the system conversion performance [54]-[56]. Thus, for the future wind power systems with high power ratings, using advanced power electronics devices can improve the whole performance in terms of efficiency and reliability.

Notably, the dramatic growth of total installations and the individual capacity make the failures of wind power or PV system costly or even unacceptable. Hence, the reliability becomes more critical for future RESs [9], [10], [14], [54]. According to previous research and field experiences, the control and power electronics systems in a RES have higher failure rate than the other subsystems. Therefore, possible improvements of the reliability can be achieved by means of: a) proper component selection (e.g. considering rated power, the most stressed situations, and the severe users, using advanced device packaging technologies, and choosing new power electronics devices), b) effective thermal management, c) robustness design and validation with the knowledge of mission profiles [9], [10], [54], [59], [61]. These considerations should be taken into account during the design and operation of a RES. It also leads to possible activities for reliability analysis and improvement, as shown in Fig. 19.

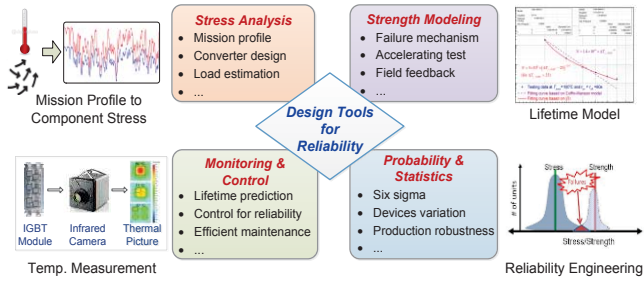

Fig. 19: Multi-disciplinary approaches for more reliable power electronics in renewable energy systems.

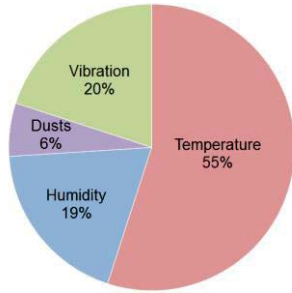

Fig. 20: Critical stresses contribute to the failures of power electronic components.

### E. More Focus on Thermal Loading Analysis

According to the statistics carried by [62], the proportion of various stresses that contribute to the failures of power electronic components is shown in Fig. 20. It can be seen that 55% of the component failures are caused by the temperature or thermal stresses. It is noted that the stress distribution in Fig. 20 could be varied depending on the application, however as reported in [63]-[66] it is generally accepted that the thermal loading is an important “trouble maker” for most of the failure mechanisms in the electronic devices, like capacitor, printed circuit board, power semiconductors, etc.

Moreover, it has been proved that thermal stresses of the power electronics components can be “translated” into corresponding lifetime of devices, as summarized in [67]-[69], where a series of lifetime models are introduced. Fig. 21 shows an example of the lifetime testing results provided by Semikron, in which several fitting curves are plotted to reveal the relationship between the thermal cycles to failure of a series of IGBTs and the applied thermal stresses – in this case the junction temperature excursion  $\Delta T_j$  and the mean junction temperature  $T_{jm}$ .

Based on the lifetime results tested by manufacturers, it is also possible to translate the complicated mission profiles of wind turbine and PV converter to the corresponding lifetime of power semiconductor devices, as detailed in [61], [70], [71]. Moreover, a new area of research can be initiated, targeting to smooth the thermal fluctuation of power devices and thereby improve the lifetime of power electronics converter.

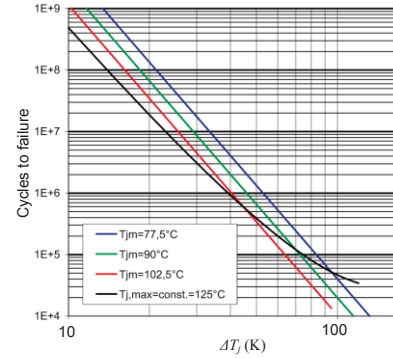

Fig. 21: Illustration of industrial standard cycles to failure vs.  $\Delta T_j$  of IGBT module by Semikron [68].

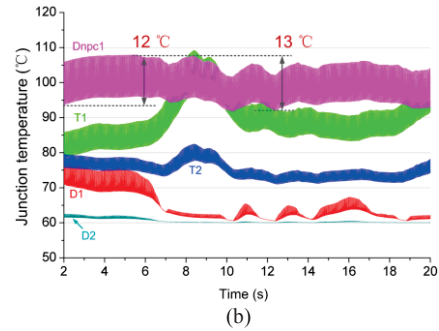
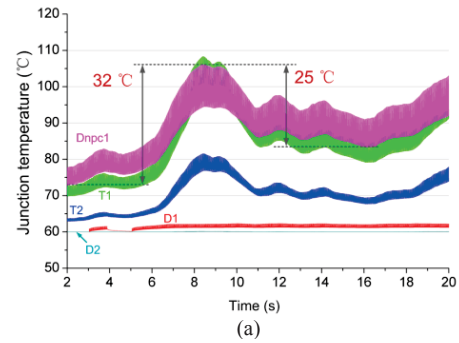

Fig. 22. Thermal loading of 3L-NPC inverter under wind gust operation: (a) without thermal control and (b) with thermal control [72].

An example is detailed in [72], in which it was found that the fluctuation/gust of wind speed could cause serious junction temperature fluctuation in the power devices – thereby compromising the reliability performance. A thermal controlling method is proposed in [72], in which the basic idea is to circulate the reactive power among paralleled converters to somehow stabilize the temperature fluctuation, as shown in Fig. 22. It can be seen that by enabling the reactive power control, the temperature fluctuation of power device caused by wind gust can be significantly smoothen – leading to improved reliability according to Fig. 21.

## VI. CONCLUSION

In this paper, issues of the key technology for renewable energy systems – power electronics have been discussed. An overview of the technology demands and

power converter topologies for kW residential PV panels as well as MW wind turbines, and the power device technologies have also been presented, together with the operation principles and control structures in different operation modes. Finally, some emerging trends for the power electronics development in the renewable energy applications are also discussed.

It can be concluded that the power electronics is an enabling technology for a reliable and efficient power generation from the renewable energy generation systems with lowered cost of energy. In the future, in order to realize even larger scale renewable energy generation and further reduce the energy cost, more advanced power electronics systems associated with more intelligent control strategies, higher efficiency and reliability will be of exceeding necessity.

#### REFERENCES

- [1] REN21, "Renewables 2013: Global Status Report (GSR)," [Online]. Available: <http://www.ren21.net/>, Jun. 2013.
- [2] REN21, "Global Futures Report (GFR) - Scenario Profiles Report (Draft)," [Online]. Available: <http://www.ren21.net/>, Jan. 2013.
- [3] E. J. Coster, J. M. A. Myrzik, B. Kruimer, and W. L. Kling, "Integration issues of distributed generation in distribution grids," *Proc. IEEE*, vol. 99, no. 1, pp. 28–39, Jan. 2011.
- [4] R. Teodorescu, M. Liserre, and P. Rodriguez, *Grid Converters for Photovoltaic and Wind Power Systems*. Hoboken, NJ, USA: Wiley, 2011.
- [5] F. Blaabjerg, R. Teodorescu, M. Liserre, and A.V. Timbus, "Overview of control and grid synchronization for distributed power generation systems," *IEEE Trans. Ind. Electron.*, vol. 53, no. 5, pp. 1398-1409, Oct. 2006.
- [6] S.B. Kjaer, J.K. Pedersen, and F. Blaabjerg, "A review of single-phase grid-connected inverters for photovoltaic modules," *IEEE Trans. Ind. Appl.*, vol. 41, no. 5, pp. 1292-1306, Sept.-Oct. 2005.
- [7] D. Meneses, F. Blaabjerg, O. Garcia, and J.A. Cobos, "Review and comparison of step-up transformerless topologies for photovoltaic AC-module application," *IEEE Trans. Power Electron.*, vol. 28, no. 6, pp. 2649-2663, Jun. 2013.
- [8] F. Blaabjerg, Z. Chen, and S.B. Kjaer, "Power electronics as efficient interface in dispersed power generation systems," *IEEE Trans. Power Electron.*, vol. 19, no. 5, pp. 1184-1194, Sept. 2004.
- [9] F. Blaabjerg, M. Liserre, and K. Ma, "Power electronics converters for wind turbine systems," *IEEE Trans. Ind. Appl.*, vol. 48, no. 2, pp. 708-719, Mar.-Apr. 2012.
- [10] F. Blaabjerg and K. Ma, "Future on power electronics for wind turbine systems," *IEEE Journal of Emerging and Selected Topics in Power Electronics*, in press, 2013.
- [11] J.M. Carrasco, L.G. Franquelo, J.T. Bialasiewicz, E. Galvan, R.C.P. Guisado, Ma.A.M. Prats, J.I. Leon, and N. Moreno-Alfonso, "Power-electronic systems for the grid integration of renewable energy sources: a survey," *IEEE Trans. Ind. Electron.*, vol. 53, no. 4, pp. 1002-1016, Jun. 2006.
- [12] M. Liserre, T. Sauter, and J.Y. Hung, "Future energy systems: Integrating renewable energy sources into the smart power grid through industrial electronics," *IEEE Ind. Electron. Mag.*, vol. 4, no. 1, pp. 18-37, Mar. 2010.
- [13] M. Liserre, R. Cardenas, M. Molinas, and J. Rodriguez, "Overview of multi-MW wind turbines and wind parks," *IEEE Trans. Ind. Electron.*, vol. 58, no. 4, pp. 1081-1095, Apr. 2011.
- [14] K. Ma and F. Blaabjerg, "Multilevel converters for 10 MW wind turbines," in *Proc. of EPE'11*, pp. 1-10, Aug. 30 2011-Sept. 1 2011.
- [15] J. Rodriguez, S. Bernet, P.K. Steimer, and I.E. Lizama, "A survey on neutral-point-clamped inverters," *IEEE Trans. Ind. Electron.*, vol. 57, no. 7, pp. 2219-2230, Jul. 2010.
- [16] F. Blaabjerg, K. Ma, and D. Zhou, "Power electronics and reliability in renewable energy systems," in *Proc. of ISIE*, pp. 19-30, 28-31 May 2012.
- [17] B. Andresen and J. Birk, "A high power density converter system for the Gamesa G10x 4.5 MW Wind turbine," in *Proc. of EPE*, pp. 1-7, 2007.
- [18] M. Altin, O. Goksu, R. Teodorescu, P. Rodriguez, B. Bak-Jensen, L. Helle, "Overview of recent grid codes for wind power integration," in *Proc. of OPTIM'2010*, pp.1152-1160, 2010.
- [19] M. Tsili, "A review of grid code technical requirements for wind farms," *IET Journal of Renewable Power Generation*, Vol.3, no.3, pp. 308-332, 2009.
- [20] Energinet – Wind turbines connected to grids with voltages below 100 kV, Jan. 2003.
- [21] Energinet – Technical regulation 3.2.5 for wind power plants with a power output greater than 11 kW, Sep. 2010.
- [22] E.ON-Netz – Grid Code. Requirements for offshore grid connections in the E.ON Netz network, April 2008.
- [23] C. Winneker, "World's solar photovoltaic capacity passes 100-gigawatt landmark after strong year," [Online], Feb. 2013. Available: <http://www.epia.org/news/>.
- [24] M. Braun, T. Stetz, R. Brundlinger, C. Mayr, K. Ogimoto, H. Hatta, H. Kobayashi, B. Kroposki, B. Mather, M. Coddington, K. Lynn, G. Graditi, A. Woyte, and I. MacGill, "Is the distribution grid ready to accept large-scale photovoltaic deployment? State of the art, progress, and future prospects," *Prog. Photovolt: Res. Appl.*, vol. 20, no. 6, pp. 681-697, 2012.
- [25] C.H. Benz, W.-T. Franke, and F.W. Fuchs, "Low voltage ride through capability of a 5 kW grid-tied solar inverter," in *Proc. of EPE/P EMC*, pp. T12-13-T12-20, 6-8 Sept. 2010.
- [26] X. Bao, P. Tan, F. Zhuo, and X. Yue, "Low voltage ride through control strategy for high-power grid-connected photovoltaic inverter," in *Proc. of APEC'13*, pp. 97-100, 17-21 Mar. 2013.
- [27] H.-C. Chen, C.-T. Lee, P.T. Cheng, R. Teodorescu, F. Blaabjerg, and S. Bhattacharya, "A flexible low-voltage ride-through operation for the distributed generation converters," in *Proc. of PEDS'13*, pp. 1354-1359, 22-25 Apr. 2013.
- [28] N.P. Papanikolaou, "Low-voltage ride-through concept in flyback inverterbased alternating current photovoltaic modules," *IET Power Electron.*, vol. 6, no. 7, pp. 1436-1448, Aug. 2013.
- [29] Y. Yang, P. Enjeti, F. Blaabjerg, and H. Wang, "Suggested grid code modifications to ensure wide-scale adoption of photovoltaic energy in distributed power generation systems," in *Proc. of IAS Annual Meeting*, pp. 1-8, 6-11 Oct. 2013.
- [30] Y. Bae, T.-K. Vu, and R.-Y. Kim, "Implemental control strategy for grid stabilization of grid-connected PV system based on german grid code in symmetrical low-to-medium voltage network," *IEEE Trans. Energy Conv.*, vol. 28, no. 3, pp. 619-631, Sept. 2013.
- [31] Y. Yang, F. Blaabjerg, and Z. Zou, "Benchmarking of grid fault modes in single-phase grid-connected photovoltaic systems," *IEEE Trans. Ind. Appl.*, vol. 49, no. 5, pp. 2167-2176, Sept./Oct. 2013.
- [32] Y. Yang, F. Blaabjerg, and H. Wang, "Low voltage ride-through of single-phase transformerless photovoltaic inverters," *IEEE Trans. Ind. Appl.*, in press, vol. 50, no. 3, May/June. 2014. DOI: 10.1109/TIA.2013.2282966.
- [33] Y. Yang, H. Wang, and F. Blaabjerg " Reactive power injection strategies for single-phase photovoltaic systems considering grid requirements," in *Proc. of APEC*, 16-20 Mar. 2014.
- [34] R. Jones and P. Waite, "Optimised power converter for multi-MW direct drive permanent magnet wind turbines," in *Proc. of EPE*, pp. 1-10, 2011.

- [35] SMA, SUNNY CENTRAL- High tech solution for solar power stations. (Available: <http://www.sma-america.com/>).
- [36] S.V. Araujo, P. Zacharias, and R. Mallwitz, "Highly efficient single-phase transformerless inverters for grid-connected PV systems," *IEEE Trans. Ind. Electron.*, vol. 57, no. 9, pp. 3118-3128, Sept. 2010.
- [37] R. Gonzalez, J. Lopez, P. Sanchis, and L. Marroyo, "Transformerless inverter for single-phase photovoltaic systems," *IEEE Trans. Power Electron.*, vol. 22, no. 2, pp. 693-697, Mar. 2007.
- [38] T. Kerekes, R. Teodorescu, P. Rodriguez, G. Vazquez, and E. Aldabas, "A new high-efficiency single-phase transformerless PV inverter topology," *IEEE Trans. Ind. Electron.*, vol. 58, no. 1, pp. 184-191, Jan. 2011.
- [39] H. Schmidt, S. Christoph, and J. Ketterer, "Current inverter for direct/alternating currents, has direct and alternating connections with an intermediate power store, a bridge circuit, rectifier diodes and a inductive choke," German Patent DE10 221 592 A1, 4 Dec. 2003.
- [40] I. Patrao, E. Figueres, F. Gonzalez-Espin, and G. Garcera, "Transformer-erless topologies for grid-connected single-phase photovoltaic inverters," *Renewable and Sustainable Energy Reviews*, vol. 15, no. 7, pp. 3423-3431, Sept. 2011.
- [41] L. Zhang, K. Sun, L. Feng, H. Wu, and Y. Xing, "A family of neutral point clamped full-bridge topologies for transformerless photovoltaic grid-tied inverters," *IEEE Trans. Power Electron.*, vol. 28, no. 2, pp. 730-739, Feb. 2013.
- [42] B. Gu, J. Dominic, J.-S. Lai, C.-L. Chen, T. LaBella, and B. Chen, "High reliability and efficiency single-phase transformerless inverter for grid-connected photovoltaic systems," *IEEE Trans. Power Electron.*, vol. 28, no. 5, pp. 2235-2245, May 2013.
- [43] Sunways, Yield-oriented solar inverters with up to 98 % peak efficiency. Product category. (Available: <http://www.sunways.eu/en/>)
- [44] Kaco, Powador XP500-HV TL central inverter. (Available: <http://www.kaco-newenergy.com/products/solar-inverters>).
- [45] K. Ma, F. Blaabjerg, "The Impact of Power Switching Devices on the Thermal Performance of a 10 MW Wind Power NPC Converter," *Energies* 5, no. 7: 2559-2577.
- [46] R. Jakob, C. Keller, B. Gollentz, "3-Level high power converter with press pack IGBT," in *Proc. of EPE' 2007*, pp. 2-5, Sept. 2007.
- [47] R. Alvarez, F. Filsecker, S. Bernet, "Comparison of press-pack IGBT at hard switching and clamp operation for medium voltage converters," in *Proc. of EPE' 2011*, pp. 1-10, 2011.
- [48] U. Scheuermann, "Reliability challenges of automotive power electronics," *Microelectronics Reliability*, vol. 49, no. 9-11, pp. 1319-1325, 2009.
- [49] U. Scheuermann, Ralf Schmidt, "A New Lifetime Model for Advanced Power Modules with Sintered Chips and Optimized Al Wire Bonds," *Proc. of PCIM' 2013*, pp. 810-813, 2013.
- [50] E. ON GmbH, "Grid Code - High and extra high voltage." [Online]. Available: <http://www.eon-netz.com/>.
- [51] Comitato Elettrotecnico Italiano, "CEI 0-21: Reference technical rules for connecting users to the active and passive LV distribution companies of electricity." [Online]. Available: <http://www.ceiweb.it/>.
- [52] P. Rodriguez, A.V. Timbus, R. Teodorescu, M. Liserre, and F. Blaabjerg, "Flexible active power control of distributed power generation systems during grid faults," *IEEE Trans. Ind. Electron.*, vol. 54, no. 5, pp. 2583-2592, Oct. 2007.
- [53] G.M.S. Azevedo, G. Vazquez, A. Luna, D. Aguilar, and A. Rolan, "Photovoltaic inverters with fault ride-through capability," in *Proc. of ISIE'09*, pp. 549-553, 5-8 Jul. 2009.
- [54] H. Wang, M. Liserre, and F. Blaabjerg, "Toward reliable power electronics: challenges, design tools, and opportunities," *IEEE Ind. Electron. Mag.*, vol. 7, no. 2, pp. 17-26, Jun. 2013.
- [55] J.D., van Wyk and F.C. Lee, "On a future for power electronics," *IEEE Journal of Emerging and Selected Topics in Power Electronics*, vol. 1, no. 2, pp. 59-72, Jun. 2013.
- [56] J.G. Kassakian and T.M. Jahns, "Evolving and emerging applications of power electronics in systems," *IEEE Journal of Emerging and Selected Topics in Power Electronics*, vol. 1, no. 2, pp. 47-58, Jun. 2013.
- [57] Y. Yang, F. Blaabjerg, and H. Wang, "Constant power generation of photovoltaic systems considering the distributed grid capacity," in *Proc. of APEC*, pp. 379-385, 16-20 Mar. 2014.
- [58] M. Campbell, J. Blunden, E. Smeloff, and P. Aschenbrenner, "Minimizing utility-scale PV power plant LCOE through the use of high capacity factor configurations," in *Proc. of IEEE PVSC*, pp. 421-426, 7-12 Jun. 2009.
- [59] E. Koutroulis and F. Blaabjerg, "Design optimization of transformerless grid-connected PV inverters including reliability," *IEEE Trans. Power Electron.*, vol. 28, no. 1, pp. 325-335, Jan. 2013.
- [60] U.S. Energy Information Administration, "Levelized cost of new generation resources in the annual energy outlook 2013," [Online] Tech. Rep., Jan. 2013. Available: <http://www.eia.gov/>.
- [61] Y. Yang, H. Wang, F. Blaabjerg, and K. Ma, "Mission profile based multi-disciplinary analysis of power modules in single-phase transformerless photovoltaic inverters," in *Proc. of EPE ECCE Europe*, pp. 1-10, 2-6 Sept. 2013.
- [62] ZVEL, Handbook for robustness validation of automotive electrical/electronic modules, Jun. 2008.
- [63] B. Tuchband, N. Vichare and M. Pecht, "A method for implementing prognostics to legacy systems," in *Proc. IMAPS Military, Aerospace, Space and Homeland Security: Packaging Issues and Applications*, 2006.
- [64] E. Wolfgang, "Examples for failures in power electronics systems," presented at *ECPE Tutorial on Reliability of Power Electronic Systems*, Nuremberg, Germany, Apr. 2007.
- [65] S. Yang, A. T. Bryant, P. A. Mawby, D. Xiang, L. Ran, and P. Tavner, "An industry-based survey of reliability in power electronic converters," *IEEE Trans. on Ind. Appl.*, vol. 47, no. 3, pp. 1441- 1451, May/June, 2011.
- [66] E. Wolfgang, L. Amigues, N. Seliger and G. Lugert, "Building-in reliability into power electronics systems". The World of Electronic Packaging and System Integration, 2005, pp. 246-252.
- [67] C. Busca, R. Teodorescu, F. Blaabjerg, S. Munk-Nielsen, L. Helle, T. Abeyasekera, P. Rodriguez, "An overview of the reliability prediction related aspects of high power IGBTs in wind power applications," *Microelectronics Reliability*, Vol. 51, no. 9-11, September-November 2011, pp. 1903-1907.
- [68] A. Wintrich, U. Nicolai, T. Reimann, "Semikron Application Manual," pp. 128, 2011.
- [69] I.F. Kovacevic, U. Drogenik, J.W. Kolar, "New physical model for lifetime estimation of power modules," in *Proc. IPEC'10*, pp. 2106-2114, 2010.
- [70] ABB Application Note, *Load-cycling capability of HiPak IGBT modules*, 2012.
- [71] K. Ma and F. Blaabjerg, "Lifetime estimation for the power semiconductors considering mission profiles in wind power converter," in *Proc. of ECCE' 2013*, Sept. 2013.
- [72] K. Ma, M. Liserre, and F. Blaabjerg, "Reactive power influence on the thermal cycling of multi-MW wind power inverter," *IEEE Trans. Ind. Appl.*, vol. 49, no. 2, pp. 922-930, 2013.