



Aalborg Universitet

AALBORG UNIVERSITY  
DENMARK

## Hybrid Active Filter with Variable Conductance for Harmonic Resonance Suppression in Industrial Power Systems

Lee, Tzung-Lin; Wang, Yen-Ching; Li, Jian-Cheng; Guerrero, Josep M.

*Published in:*

I E E E Transactions on Industrial Electronics

*DOI (link to publication from Publisher):*

[10.1109/TIE.2014.2347008](https://doi.org/10.1109/TIE.2014.2347008)

*Publication date:*

2015

*Document Version*

Early version, also known as pre-print

[Link to publication from Aalborg University](#)

*Citation for published version (APA):*

Lee, T-L., Wang, Y-C., Li, J-C., & Guerrero, J. M. (2015). Hybrid Active Filter with Variable Conductance for Harmonic Resonance Suppression in Industrial Power Systems. I E E E Transactions on Industrial Electronics, 62(2), 746 - 756 . DOI: 10.1109/TIE.2014.2347008

### General rights

Copyright and moral rights for the publications made accessible in the public portal are retained by the authors and/or other copyright owners and it is a condition of accessing publications that users recognise and abide by the legal requirements associated with these rights.

- ? Users may download and print one copy of any publication from the public portal for the purpose of private study or research.
- ? You may not further distribute the material or use it for any profit-making activity or commercial gain
- ? You may freely distribute the URL identifying the publication in the public portal ?

### Take down policy

If you believe that this document breaches copyright please contact us at [vbn@aub.aau.dk](mailto:vbn@aub.aau.dk) providing details, and we will remove access to the work immediately and investigate your claim.

# Hybrid Active Filter with Variable Conductance for Harmonic Resonance Suppression in Industrial Power Systems

**Abstract**—Unintentional series and/or parallel resonances, due to the tuned passive filter and the line inductance, may result in severe harmonic distortion in the industrial power system. This paper presents a hybrid active filter to suppress harmonic resonance and reduce harmonic distortion as well. The proposed hybrid filter is operated as variable harmonic conductance according to the voltage total harmonic distortion, so harmonic distortion can be reduced to an acceptable level in response to load change or parameter variation of power system. Since the hybrid filter is composed of a seventh-tuned passive filter and an active filter in series connection, both dc voltage and kVA rating of the active filter are dramatically decreased compared with the pure shunt active filter. In real application, this feature is very attractive since the active power filter with fully power electronics is very expensive. A reasonable trade-off between filtering performances and cost is to use the hybrid active filter. Design consideration are presented and experimental results are provided to validate effectiveness of the proposed method. Furthermore, this paper discusses filtering performances on line impedance, line resistance, voltage unbalance and capacitive filters.

## KEYWORDS

Hybrid active filter, harmonic resonance, industrial power system

## NOMENCLATURE

$v_s$	source voltage
$i_s$	source current
$i_L$	load current
$i$	filter current
$L_s$	source inductor
$R_s$	source resistor
$L_f$	filter inductor
$C_f$	filter capacitor
$R_f$	filter resistor
$C_{dc}$	dc capacitor of the hybrid filter
$v_{dc}$	dc voltage of the hybrid filter
$v_{dc}^*$	dc voltage command
$e$	terminal voltage
$e_{qd}^e$	terminal voltage in the SRF
$e_{qd,h}^e$	terminal harmonic voltage in the SRF
$e_h$	terminal harmonic voltage
$\omega_h$	harmonic frequency in radian
$i_h^*$	harmonic current command
$i_f^*$	fundamental current command
$i^*$	current command
$G^*$	conductance command
$k_p$	proportional gain of the tuning control
$k_i$	integral gain of the tuning control

$K_c$	proportional gain of the current controller
THD*	voltage THD command
$I_h$	filter harmonic current amplitude
$E(s)$	terminal voltage in s-domain
$I(s)$	filter harmonic in s-domain
$I^*(s)$	filter harmonic command in s-domain

## I. INTRODUCTION

Harmonic pollution is becoming increasingly serious due to extensive use of nonlinear loads, such as adjustable speed drives, uninterruptible power supply systems, battery charging system, etc. These equipment usually uses diode or thyristor rectifiers to realize power conversion because of lower component cost and less control complexity. However, the rectifiers will contribute a large amount of harmonic current flowing into the power system and the resulting harmonic distortion may give rise to malfunction of sensitive equipment or interfering with communication systems in the vicinity of the harmonic sources. Normally, tuned passive filters are deployed at the secondary side of the distribution transformer to provide low impedance for dominant harmonic current and correct power factor for inductive loads [1], [2]. However, due to parameter variations of passive filters, unintentional series and/or parallel resonances may occur between the passive filter and line inductance. The functionality of the passive filter may deteriorate and excessive harmonic amplification may result [3], [4]. Thus, extra calibrating work must be consumed to maintain the filtering capability.

Various active filtering approaches have been presented to address the harmonic issues in the power system [5], [6], [7]. The active filter intended for compensating harmonic current of nonlinear loads is the most popular one, but it may not be effective for suppressing harmonic resonances [8]. Bhattacharya et al. proposed a hybrid series active filter to isolate harmonics between the power system and the harmonic source [9]. A so-called "active-inductance" hybrid filter was presented to improve the performance of the passive filter [10]. Fujita et al. proposed a hybrid shunt active filter with filter-current detecting method to suppress the fifth harmonic resonance between the power system and a capacitor bank [11]. A hybrid filter in series with a capacitor bank by a coupling transformer was proposed to suppress the harmonic resonance as well as to compensate harmonic current [12], [13]. However, this method needs extra matching transformers or tuned passive filters to guarantee filtering functionality.

Recently, a transformerless hybrid active filter was presented to compensate harmonic current and/or fundamental reactive

current [14], [15], [16], [17], [18]. Design consideration of the hybrid filter for current compensation has been extensively studied. Hybrid active filter with damping conductance was proposed to suppress harmonic voltage propagation in distribution power system [19]. Nevertheless, this method did not consider the resonance between the passive filter and the line inductance. The fixed conductance may deteriorate the damping performances. An anti-resonance hybrid filter for delta-connected capacitor bank of power-factor-correction applications was presented [20]. This circuit was limited to three single-phase inverters and the filtering performance was not considered. In addition, the hybrid active filter was proposed for the unified power quality conditioner to address PQ issues in the power distribution system [21]. Several case studies of the hybrid active filter considering optimal voltage or current distortion were conducted in [22].

In previous work, the authors have presented a transformerless hybrid active filter to suppress harmonic resonances in the industrial power system in [23], [24]. The hybrid filter is constructed by a seventh-tuned passive filter and an active filter in series connection. It operates as a variable conductance at harmonic frequencies according to the voltage total harmonic distortion (THD), so that harmonic distortion can be reduced to an acceptable level in response to load change and power system variation. Since the series capacitor is responsible for sustaining the fundamental component of the grid voltage, the active filter is able to operate with a very low dc bus voltage, compared with the pure shunt active filter [14], [19]. Hence, both the rated kVA capacity and the switching ripples are reduced accordingly. Moreover, the proposed harmonic conductance is able to avoid overcurrent of the passive filter in case of mistuning parameters. These features will benefit practical applications.

In this work, we further present designing consideration of the hybrid filter. A prototype circuit of the hybrid filter based on 220V/10kVA system has been established to verify theoretic analysis, including steady-state behavior, transient response and stability analysis. The filtering performance of the hybrid filter is discussed considering X/R ratio and magnified variations of line impedance. We also focus on filtering deterioration due to line resistance, voltage unbalance and capacitive filters in the power system. In many cases, active power filter is designed to compensate harmonic current produced by a specific nonlinear load, in such a way that it needs to measure the load current to be compensated [14], [25]. In this paper, the active filter is designed as a harmonic conductance to suppress harmonic resonance and harmonic distortion as well by using local voltage measurement. Notice that it does not require current information of the nonlinear loads. Thus this approach can be suitable as well in power distribution networks in which the loads can be distributed along a feeder [19]. In addition, compensating fundamental reactive power due to unbalanced load is possible, but it is out of scope of this research [25], [26].

## II. OPERATION PRINCIPLE

Fig. 1(a) shows a simplified circuit diagram considered in this paper, where  $L_s$  represented the line inductance plus the

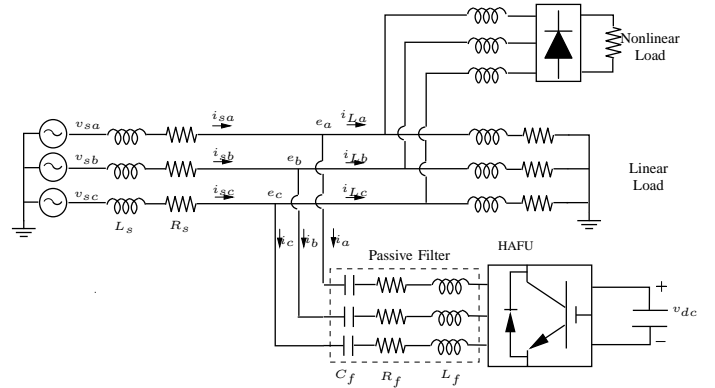

(a) Circuit diagram of the HAFU.

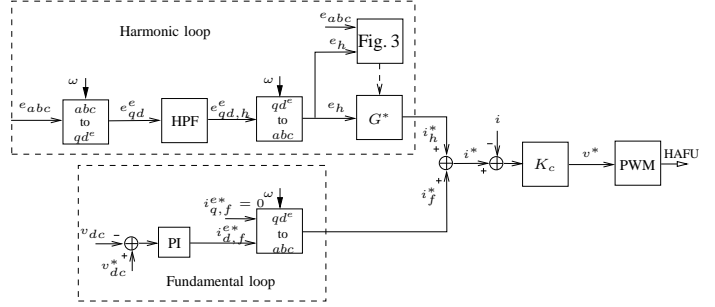

(b) Control block diagram of the HAFU.

Fig. 1. The proposed hybrid active filter unit (HAFU) in the industrial power system and its associated control.

leakage inductance of the transformer. The hybrid active filter unit (HAFU) is constructed by a seventh-tuned passive filter and a three-phase voltage source inverter in series connection. The passive filter  $L_f - C_f$  is intended for compensating harmonic current and reactive power. The inverter is designed to suppress harmonic resonances and improve the filtering performances of the passive filter. Fig. 1(b) shows the overall control block diagram of the HAFU, including harmonic loop, fundamental loop, current regulator, and conductance control. Detailed principle will be presented as follows.

### A. Harmonic loop

In order to suppress harmonic resonances, the HAFU is proposed to operate as variable conductance at harmonic frequencies as given,

$$i_h^* = G^* \cdot e_h \quad (1)$$

where  $i_h^*$  represents the harmonic current command. The conductance command  $G^*$  is a variable gain to provide damping for all harmonic frequencies. Harmonic voltage component  $e_h$  is obtained by using the so-called synchronous reference frame (SRF) transformation [9], where a phase-locked loop (PLL) is realized to determine the fundamental frequency of the power system [27]. In the SRF, the fundamental component becomes a dc value and other harmonic components are still ac values. Therefore, harmonic voltage component  $e_{qd,h}^e$  can be extracted from  $e_{qd}^e$  by using high-pass filters (HPFs). After transferring back to three-phase system, the harmonic current command  $i_h^*$  is obtained by multiplying  $e_h$  and the conductance command  $G^*$  as shown in (1).

## B. Fundamental loop

In this paper, the q axis is aligned to a-phase voltage. Since the passive filter shows capacitive at the fundamental frequency, the passive filter draws fundamental leading current from the grid, which is located on the d axis. The proposed inverter produces slight fundamental voltage on the d axis, which is in phase with the fundamental leading current. Therefore, the control of dc bus voltage is able to be accomplished by exchanging real power with the grid. Thus the current command  $i_{d,f}^{e*}$  is obtained by a proportional-integral (PI) controller. The fundamental current command  $i_f^*$  in the three-phase system is generated after applying the inverse SRF transformation.

(2) shows harmonic voltage drop on the passive filter due to compensating current of the HAFU [19], where  $I_h$  represents the maximum harmonic current of the active filter and voltage drop on filter resistance  $R_f$  is neglected. As can be seen, large filter capacitor results in reduction of required dc voltage. On the other hand, the filter capacitor determines reactive power compensation of the passive filter at the fundamental frequency. Thus the dc voltage  $v_{dc}^*$  can be determined based on this compromise. Note that the compensating current should be limited to ensure that the hybrid filter operates without undergoing saturation.

$$v_{dc} > 2\sqrt{2} \sum_h \left| \frac{1}{j\omega_h C_f} + j\omega_h L_f \right| \cdot I_h. \quad (2)$$

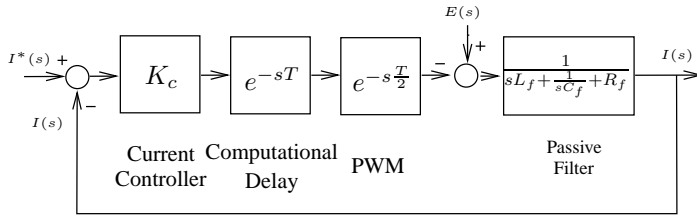

Fig. 2. Closed-loop model of the current control.

## C. Current regulator

The current command  $i^*$  is consisted of  $i_h^*$  and  $i_f^*$ . Based on the current command  $i^*$  and the measured current  $i$ , the voltage command  $v^*$  can be derived by using a proportional controller as follows,

$$v^* = K_c \cdot (i^* - i) \quad (3)$$

where  $K_c$  is a proportional gain. According to the voltage command  $v^*$ , the space vector PWM is employed to synthesize the required output voltage of the inverter. Fig. 2 shows the model of the current control. Computational delay of digital signal processing is equal to one sampling delay  $T$  and PWM delay approximates to half sampling delay  $\frac{T}{2}$ . Hence, the proportional gain  $K_c$  can be simply evaluated from both open-loop and closed-loop gains for suitable stability margin and current tracking capability. Frequency-domain analysis of current control will be given in the experimental section.

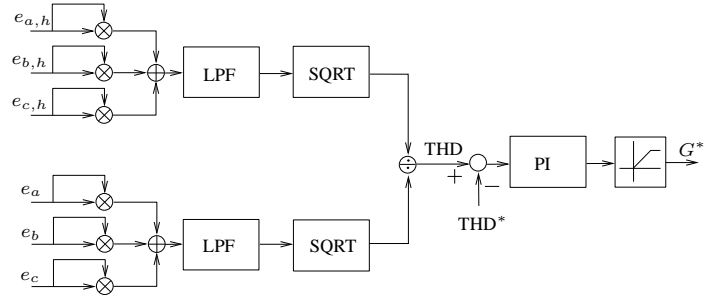

Fig. 3. Conductance control block diagram.

## D. Conductance control

Fig. 3 shows the proposed conductance control. The harmonic conductance command  $G^*$  is determined according to the voltage THD at the HAFU installation point. The voltage THD is approximately calculated by the control shown in Fig.3. Here, two low-pass filters (LPFs) with cut-off frequency  $f_{LP}=20\text{Hz}$  are realized to filter out ripple components [28], [29]. The error between the allowable THD\* and the measured THD is then fed into a PI controller to obtain the harmonic conductance command  $G^*$ . The allowable distortion could be referred to the harmonic limit in IEEE std. 519-1992 [30]. Note that PI parameters need to be tuned for required response and stability. For example, the proportional gain can be tuned for suppressing the steady-state error. The bandwidth should be lower than one-tenth of the cut-off frequency of the current loop to assure stable operation. This way the HAFU is able to dynamically adjust  $G^*$  to maintain harmonic distortion at an allowable level.

## III. ANALYSIS OF FILTERING PERFORMANCE

The filtering performance of the HAFU has been addressed in [24] by developing equivalent circuit models, in which both harmonic impedance and harmonic amplification are considered. The frequency characteristic of the passive filter is changed by the proposed harmonic conductance in order to avoid unintentional resonances. In this section, we will concentrate on the damping performance with variation of line impedance  $L_s$ , line resistance  $R_s$  and THD\*. Voltage unbalance and filter capacitors in the power system are also considered.

### A. $L_s$ on damping performances

Fig. 4 shows voltage THD for various values of  $L_s$ . Fifth harmonic voltage is severely amplified at  $L_s=0.3\text{mH}(2.3\%)$  as shown in Fig. 4(a). This resonance is alleviated if  $L_s$  is not equal to 2.3%. However, voltage distortion is still significant due to harmonic voltage drop on  $L_s$ . After the HAFU is started, Fig. 4(b) shows voltage distortion is maintained at 2% by increasing  $G^*$  as shown in Fig. 4(c). It is worth noting that the HAFU is operated at anti-resonance mode, i.e.  $G^*=0$ , if  $L_s$  is less than 2.3% for  $NL_1$ . This means that the voltage distortion is less than 2%. At that time, a lower THD\* command is needed to further reduce the current distortion of  $i_s$ .

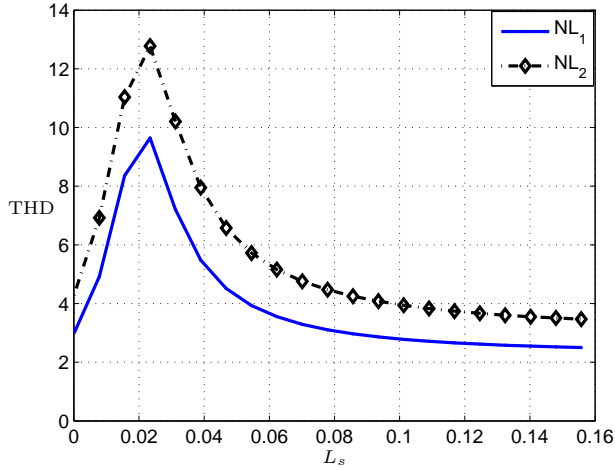

(a) Voltage THD at  $e$  when the HAFU is off.

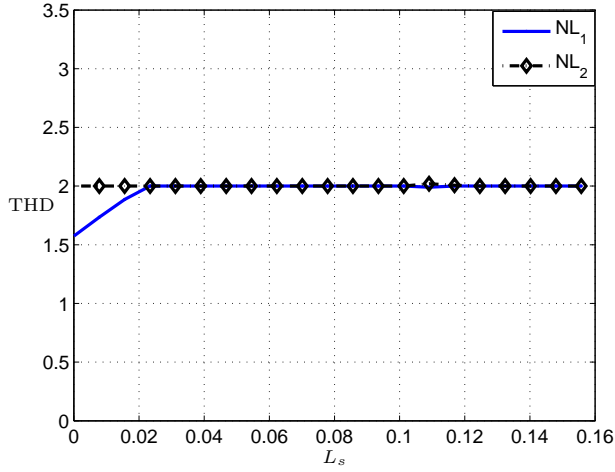

(b) Voltage THD at  $e$  when the HAFU is on.

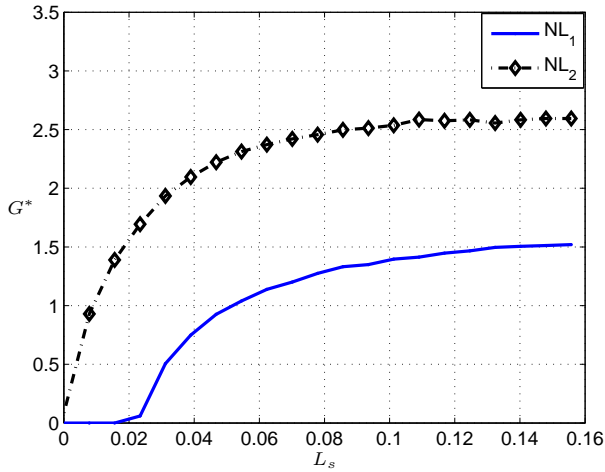

(c)  $G^*$  when the HAFU is on.

Fig. 4. Voltage THD(%) and the required  $G^*$ (pu) with varying line impedance  $L_s$ (pu).

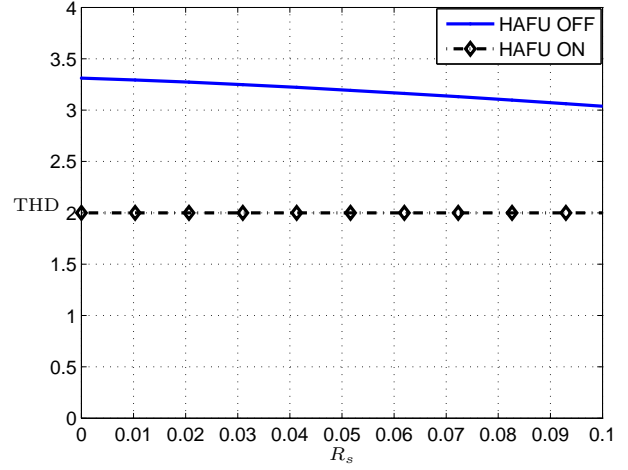

(a) Voltage THD at  $e$ .

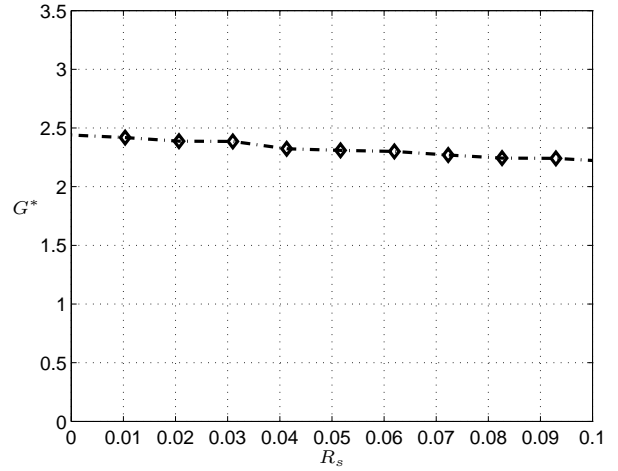

(b)  $G^*$  when the HAFU is on.

Fig. 5. Voltage THD(%) and the required  $G^*$ (pu) with varying line resistance  $R_s$ (pu).

### B. $R_s$ on damping performances

In the low-voltage system,  $X/R$  ratio becomes lower and line resistance on damping performances must be taken into consideration. Fig. 5(a) shows voltage distortion with varying  $R_s$  for  $NL_2$ . Since increasing  $R_s$  could help in reducing voltage distortion, the required conductance to maintain voltage distortion at 2% is accordingly reduced as shown in Fig. 5(b). From this observation, the HAFU could provide effective damping capability even though  $R_s$  is as large as 10%.

### C. Determination of THD\*

According to IEEE std. 519-1992 [30], voltage THD is limited to 5% and individual distortion should be below 4%. Thus THD\* is set in the range of 3% and 5%. If  $v_{s,h}$  and  $R_s$  are neglected, voltage THD at  $E$ , due to harmonic current  $I_h$ , can be expressed as follows,

$$\text{THD} = X_{pu} \sqrt{\sum_h (h \cdot I_{h,pu})^2}. \quad (4)$$

$X$  represents the series impedance of both  $L_s$  and leakage inductance of transformer. In this section, we will consider three cases in TABLE I to illustrate how to determine voltage THD\*, where only fifth and seventh harmonics are considered. In the first one, fifth harmonic is dominant, so THD\* lower than  $0.2X_{pu}$  is a sufficient condition to confirm with the harmonic limit. If fifth and seventh harmonics have the same distortion,  $\text{THD}^*=0.22X_{pu}$  is acceptable. When seventh harmonic becomes critical,  $\text{THD}^*=0.32X_{pu}$  works in the third case. Therefore, the first case is the critical one to determine the required THD\*. Note that THD\* should be reduced to enhance filtering capability in case of low system impedance.

TABLE I  
CALCULATION OF THD\*.

	$I_{5,pu}$	$I_{7,pu}$	THD
Case 1	0.04	0.03	$0.2X_{pu}$
Case 2	0.035	0.035	$0.22X_{pu}$
Case 3	0.03	0.04	$0.32X_{pu}$

#### D. Capacitive filters

In power electronic equipment, low-pass filters or EMI filters are usually installed at the grid side of the inverter to alleviate switching ripples into the power system. Since these filters present capacitive characteristics, harmonic resonances may unintentionally occur [31], [32], [33], [34], [35]. This scenario becomes much more significant in the so-called micro-grid system because a large number of output filters installed by the inverter-based distributed generators may participate in resonances [36]. Fig. 6 shows harmonic impedance and source current amplification for different capacitors  $C_e$  installed at PCC. As can be seen,  $C_e$  shifts the resonant frequency and induce another high-frequency resonance, which may result in serious harmonics. Simulation results in Fig. 7 show amplification of  $E_h$  and  $i_{s,h}$  can be effectively suppressed by the proposed hybrid filter. Note that filtering capability is dependent on the bandwidth of the HAFU.

#### E. Voltage unbalance

Voltage unbalance in low-voltage system is usually significant due to high line impedance and uneven distribution of single-phase loads [37]. Large unbalance may cause second-order harmonics in executing SRF control of the HAFU. In this sense we need to add a band-rejected filter tuned at the second order harmonic frequency in Fig. 1 to reduce this unwanted component. We also can use second-order generalized integrator (SOGI)-based methods to separate negative-sequence component [38] in the proposed control. It is worth nothing that unbalanced voltage or unbalanced current is possible to be compensated by the proposed HAFU. In this case, the HAFU has to generate fundamental negative-sequence voltage. This issue is open for further research.

### IV. EXPERIMENTAL VERIFICATION

A power stage setup was built and tested as shown in Fig. 8. TABLE II gives experimental parameters based on the per

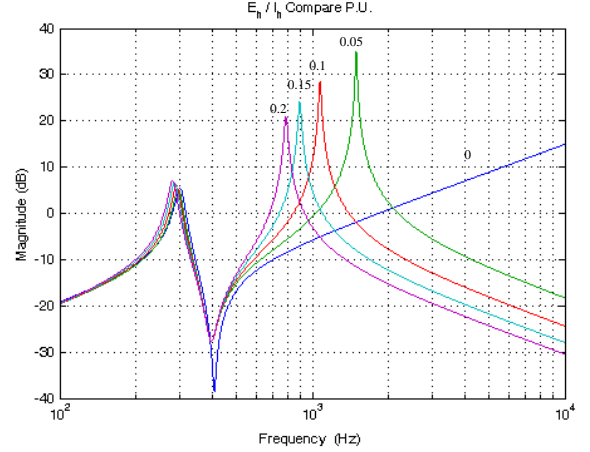

(a) Harmonic impedance.

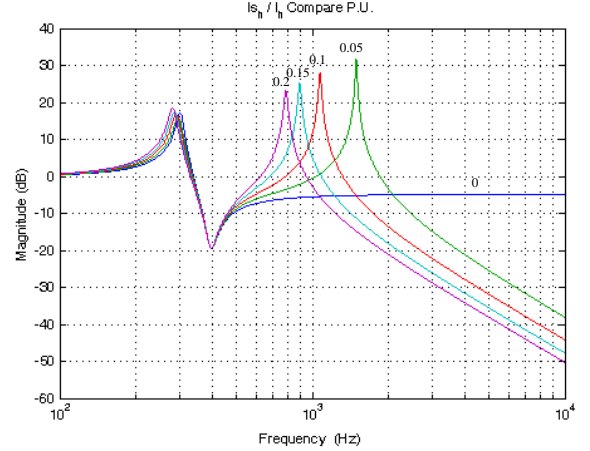

(b) Source current amplification.

Fig. 6. Harmonic amplification considering different passive filter capacitors  $C_e$ (0.05,0.1,0.15,0.2 pu).

unit system in TABLE III.  $VD_5$  and  $VD_7$  represent fifth and seventh voltage distortion in the laboratory. The filter capacitor  $C_F$  is designed to compensate inductive load and the filter inductor  $L_F$  is chosen so that the LC filter is resonant at seventh order harmonic frequency. The dc link capacitor is based on the allowed voltage ripple (5%). The control of the hybrid filter was implemented by the evaluation platform of TMS320F28335 chip [39] to perform the phase-locked loop, the synchronous reference frame transformation, low-pass filters, PI controllers, current regulator, A/D conversion and PWM units. Note that the OFF state of the HAFU corresponds to turning on three upper switches and turning off three lower switches, which means the three phases of the inverter are short-circuited. At this moment the HAFU works as a pure passive filter.

TABLE II  
EXPERIMENTAL PARAMETERS

Power system	220 V(L-L), 60Hz, $VD_5=0.7\%$ , $VD_7=0.5\%$
Transformer	220/127 V, 10 kVA, impedance 5%
Resistive load	2kW(20%)
Nonlinear load	$NL_1=1.8kW(18\%)$ , $NL_2=2.8kW(28\%)$
Passive filter	$L_f = 1.0\text{ mH}(7.8\%)$ , $C_f = 150\text{ }\mu\text{F}(27\%)$ $Q_f = 20$
Switching frequency	10 kHz
Sampling frequency	20 kHz
Current control	$k_c=5\text{ V/A}$
DC voltage control	$k_p=1\text{ A/V}$ , $k_i=100\text{ A/(V}\cdot\text{s)}$ , $v_{dc}^*=50\text{V}$
Tuning control	$k_p=1\text{ A/V}$ , $k_i=500\text{ A/(V}\cdot\text{s)}$ , $\text{THD}^*=2.0\%$ $f_{HP}=10\text{ Hz}$ , $f_{LP}=20\text{ Hz}$

TABLE III  
BASE VALUE

Voltage	220 V
kVA	10 kVA
Impedance	4.84 $\Omega$
Conductance	0.207 $\Omega^{-1}$

TABLE IV  
HARMONIC DISTORTION FOR  $NL_1=1.8\text{ kW}$ .

(a) Voltage distortion of  $e$ .

	THD	HD <sub>5</sub>	HD <sub>7</sub>	HD <sub>11</sub>	HD <sub>13</sub>
HAFU OFF	2.9%	2.7%	0.1%	0.5%	0.4%
HAFU ON	2.0%	1.6%	0.9%	0.5%	0.4%

(b) Current distortion of  $i_s$ .

	THD	HD <sub>5</sub>	HD <sub>7</sub>	HD <sub>11</sub>	HD <sub>13</sub>
HAFU OFF	8.5%	8.2%	1.7%	0.3%	0.2%
HAFU ON	4.8%	3.7%	2.8%	0.4%	0.4%

(c) Current distortion of  $i_L$ .

	THD	HD <sub>5</sub>	HD <sub>7</sub>	HD <sub>11</sub>	HD <sub>13</sub>
HAFU OFF	9.1%	7.3%	4.3%	2.8%	1.6%
HAFU ON	9.1%	7.7%	3.4%	2.5%	1.5%

(d) Current distortion of  $i$ .

	THD	HD <sub>5</sub>	HD <sub>7</sub>	HD <sub>11</sub>	HD <sub>13</sub>
HAFU OFF	27%	25%	9.2%	3.7%	2.3%
HAFU ON	12%	8.9%	6.7%	3.7%	2.0%

TABLE V  
HARMONIC DISTORTION FOR  $NL_2=2.8\text{ kW}$ .

(a) Voltage distortion of  $e$ .

	THD	HD <sub>5</sub>	HD <sub>7</sub>	HD <sub>11</sub>	HD <sub>13</sub>
HAFU OFF	4.6%	4.5%	0.1%	0.6%	0.4%
HAFU ON	2.0%	1.6%	0.8%	0.5%	0.3%

(b) Current distortion of  $i_s$ .

	THD	HD <sub>5</sub>	HD <sub>7</sub>	HD <sub>11</sub>	HD <sub>13</sub>
HAFU OFF	17%	16%	2.1%	0.6%	0.3%
HAFU ON	4.3%	3.3%	2.1%	0.4%	0.4%

(c) Current distortion of  $i_L$ .

	THD	HD <sub>5</sub>	HD <sub>7</sub>	HD <sub>11</sub>	HD <sub>13</sub>
HAFU OFF	13%	10%	6.5%	3.6%	2.2%
HAFU ON	14%	13%	5.5%	3.7%	2.1%

(d) Current distortion of  $i$ .

	THD	HD <sub>5</sub>	HD <sub>7</sub>	HD <sub>11</sub>	HD <sub>13</sub>
HAFU OFF	43%	41%	13%	4.5%	2.7%
HAFU ON	21%	17%	9.2%	5.6%	3.0%

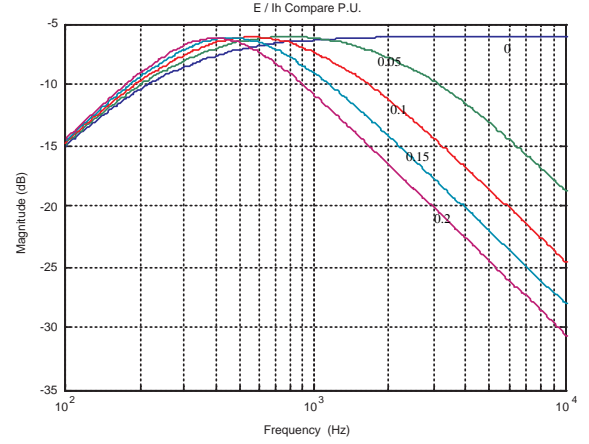

(a) Harmonic impedance.

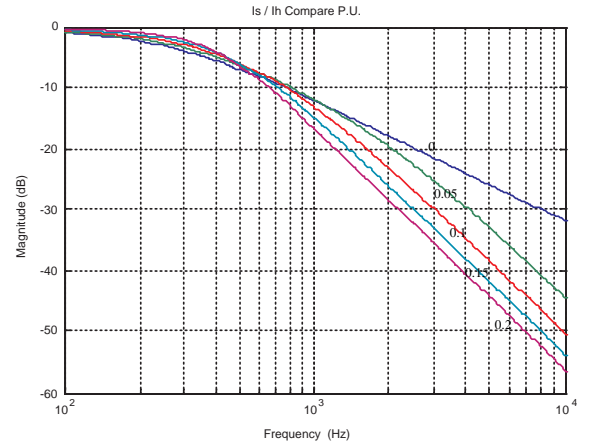

(b) Source current amplification.

Fig. 7. Damping performances for different passive filter capacitors  $C_e(0.05,0.1,0.15,0.2\text{ pu})$  with  $G^*=2.0\text{ pu}$ .

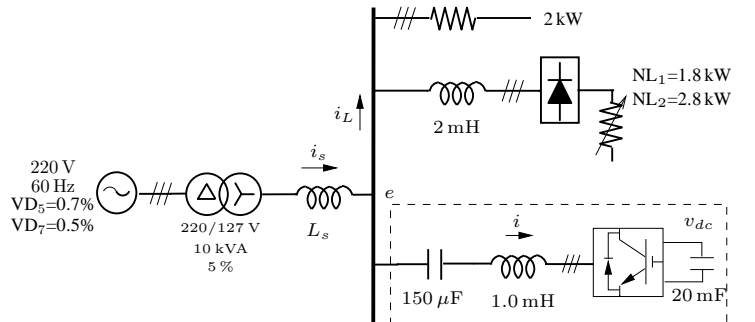
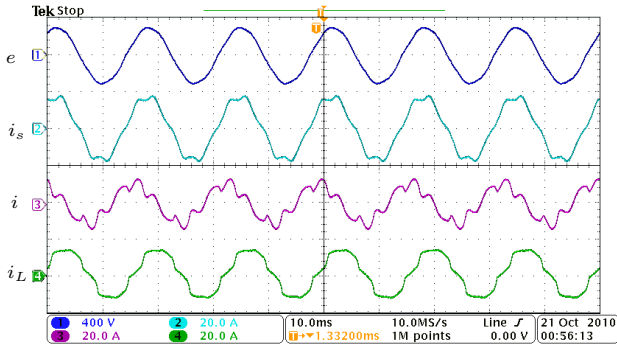

Fig. 8. Experimental setup.

### A. Three-phase load

Fig. 9 and Fig. 10 show the grid voltage  $e$ , the source current  $i_s$ , the filter current  $i$ , and the load current  $i_L$  for  $NL_1=1.8\text{ kW}$  and  $NL_2=2.8\text{ kW}$ , respectively. When the HAFU is in the OFF state, the HAFU becomes a passive filter. Since the resonant frequency between the passive filter  $L_f - C_f$  and line inductance  $L_s$  is close to fifth harmonic frequency, fifth



(a) The HAFU is off.

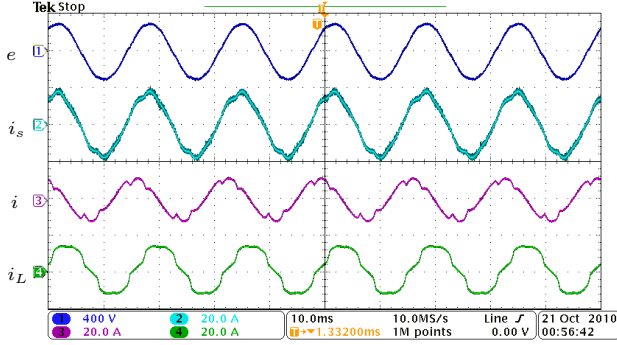

(b) The HAFU is on.

Fig. 9. Line voltage  $e$ , source current  $i_s$ , load current  $i_L$ , and filter current  $i$  in case of  $NL_1$  initiated. X axis:  $5\text{ms/div}$ .

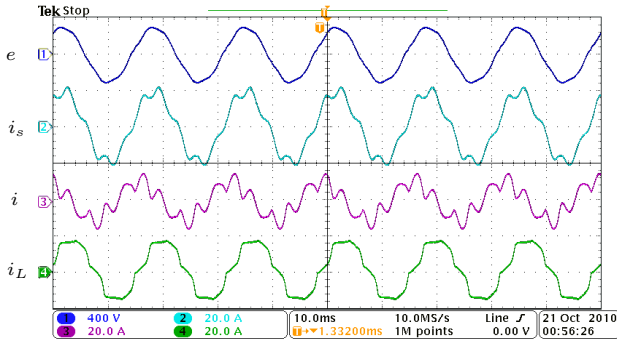

(a) The HAFU is off.

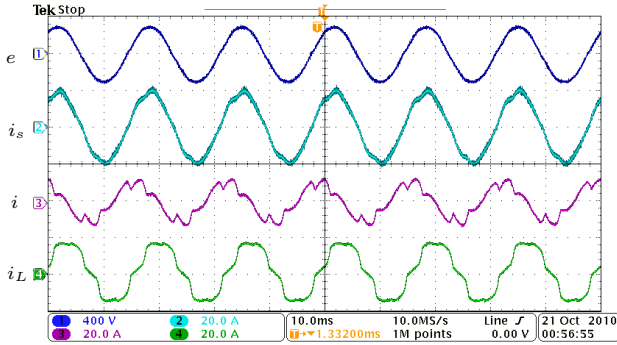

(b) The HAFU is on.

Fig. 10. Line voltage  $e$ , source current  $i_s$ , load current  $i_L$ , and filter current  $i$  in case of  $NL_2$  initiated. X axis:  $5\text{ms/div}$ .

harmonic distortion on  $e$ ,  $i_s$ ,  $i_f$  are significantly amplified as shown in Fig. 9(a) and Fig. 10(a). As can be seen, the passive filter loses its filtering functionality and even causes excessive harmonic current in  $i_s$  or harmonic voltage on  $e$ . It is worth noting that the resonant frequency could be shifted toward the lower frequency due to existing of the leakage inductance of the transformer.

After the start of the HAFU, the harmonic distortion is clearly improved as shown in Fig. 9(b) and Fig. 10(b). THD of  $e$  is reduced to 2.0% with  $G^*=0.97$  pu for  $NL_1$  and  $G^*=3.05$  pu for  $NL_2$ , respectively. THD of  $i_s$  is also improved below 5% in both cases. TABLE IV and TABLE V summarize THD data of  $e$ ,  $i_s$ ,  $i$ ,  $i_L$  measured by a power quality analyzer (HIOKI 3196). High-order harmonics ( $> 13$ ) are not included here due to insignificance. Seventh harmonic voltage distortion is increased after the HAFU is started. This is because the HAFU emulates conductance for all harmonic frequencies. This feature can be used to avoid the overloading of the passive filter at the tuned (seventh) frequency. We also observe that fifth harmonic component of load current  $i_L$  is slightly increased. This may result from improvement of fifth voltage distortion on  $e$ .

The detailed results indicate that the proposed HAFU is able to suppress harmonic resonances as well as reduce harmonic distortion. More importantly, the HAFU only consumes 470 VA, which is approximately 4.7% of the system rating or 16.7% of  $NL_2$ . Obviously, the required kVA rating of the filter is significantly reduced, in comparison with the use of a pure shunt active power filter.

Fig. 11 shows the transient waveforms of  $G^*$ , THD of  $e$ ,  $v_{dc}$  as the nonlinear load is changed by a stepped increase from  $NL_1$  to  $NL_2$  at  $T$ . Large nonlinear current will result in large voltage distortion on  $e$ . Thanks to the proposed tuning control, the conductance command  $G^*$  is increased to 3.05 pu to draw more harmonic current shown in Fig. 11(b) in order to maintain voltage THD at 2%. Fig. 11(a) also demonstrates  $v_{dc}$  is well controlled to 50V to ensure proper operation of the active filter.

## B. Comparison with current-compensating method

Additionally, time-domain simulations have been carried out to compare filtering performances between current-compensating and voltage-damping hybrid active filters. In the current-compensating case, the load current is measured and harmonic components are extracted by using synchronous reference frame transformations. In Fig. 12, source current THDs and individual harmonic distortions are given for both light and heavy nonlinear load conditions. As shown, both methods are able to reduce source current distortion and their filtering performances are similar. Further, by using the proposed approach, a small voltage THD\* value can provide even better filtering results, e.g.  $\text{THD}^* < 1.8\%$ . In [25], current-compensating hybrid active filter has been presented. Experimental results from [25] show that source current distortion can be reduced from 14.2% to 4.3%, which is similar to the results of the proposed voltage-damping hybrid filter as given in TABLE V.



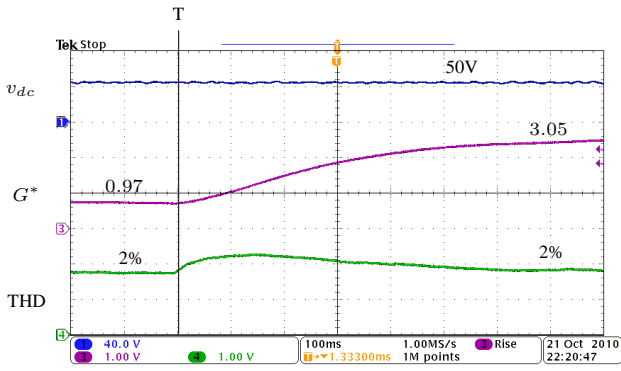

(a) Waveforms of  $v_{dc}$ , Voltage THD,  $G^*$ . X axis: 100ms/div; Y axis:  $v_{dc}$ (V),  $G^*$ (1.21 pu/div), THD(1.25 %/div)

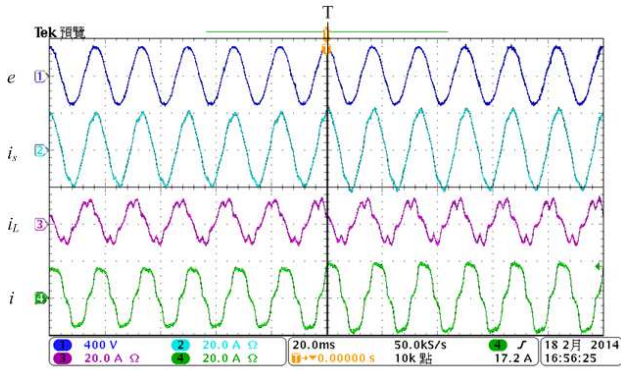

(b) Current waveforms.

Fig. 11. Transient response when the nonlinear load is increased at T.

### C. Single-phase load

In addition, filtering experiment considering single-phase nonlinear load is conducted. The setup of three-phase diode rectifier is changed to single-phase one by adding a smooth dc capacitor  $560 \mu\text{F}$ . Since the nonlinear load is connected between a- and b-phase, large third-order harmonic current is generated between them. As shown in Fig. 13, harmonic current is amplified between the source current  $i_s$  and the filter current  $i$ . After the HAFU is started, harmonic resonance is suppressed and current distortion is reduced as indicated in Fig. 14. Test results are summarized in TABLE VI. Voltage distortion of  $e$  is reduced from 4.6% to 3.0% with conductance command  $G^*=0.5$  pu. **Since the passive filter is tuned at the seventh-order harmonic frequency, the proposed hybrid filter is not able to suppress third-order harmonic distortion effectively for single-phase nonlinear load. In this case, the passive filter might be tuned at fifth-order harmonic frequency to improve filtering performance for third-order harmonic.**

### D. Stability analysis

The open-loop gain of the current control can be obtained according to Fig. 2. As shown in Fig. 15(a), the resonant peak is due to the passive filter. In this paper, the proportional gain  $K_c$  is chosen so that the bandwidth is approximately 970Hz with phase margin 83 degree. Closed-loop gain in Fig. 15(b) also demonstrates that current tracking performance is acceptable for low-order harmonic frequencies. However,

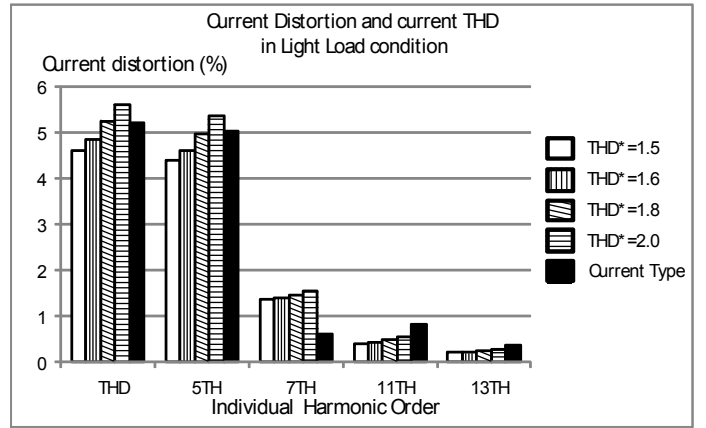

(a) Current distortion in light load condition.

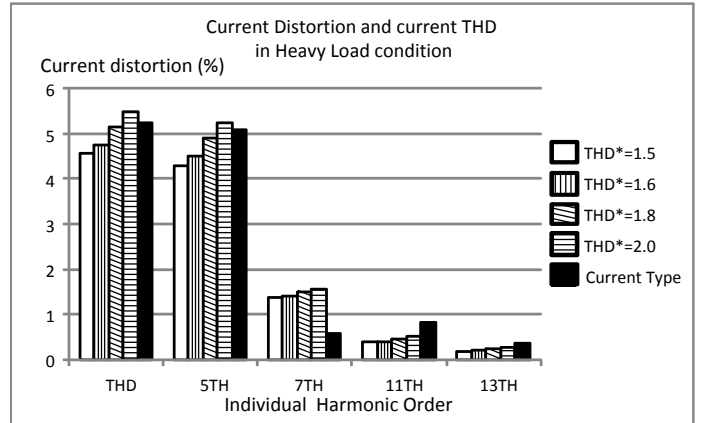

(b) Current distortion in heavy load condition.

Fig. 12. Filtering comparison between current-compensating and voltage-damping hybrid active filters.

TABLE VI  
HARMONIC DISTORTION FOR SINGLE-PHASE NONLINEAR LOAD.

(a) Voltage distortion of  $e$ .

	$e_{ab}$	$e_{bc}$	$e_{ca}$
HAFU OFF	6.3%	4.1%	2.4%
HAFU ON	4.1%	2.6%	1.8%

(b) Current distortion of  $i_s$ .

	$i_{sa}$	$i_{sb}$	$i_{sc}$
HAFU OFF	19%	28%	3.8%
HAFU ON	12%	16%	2.5%

(c) Current distortion of  $i_L$ .

	$i_{La}$	$i_{Lb}$	$i_{Lc}$
HAFU OFF	13%	13%	1.2%
HAFU ON	13%	13%	1.2%

(d) Current distortion of  $i$ .

	$i_a$	$i_b$	$i_c$
HAFU OFF	22%	25%	6.4%
HAFU ON	11%	12%	4.7%

the current control can be further improved by using the so-called resonant controller [40], [41].

## V. CONCLUSION

This paper presents a hybrid active filter to suppress harmonic resonances in industrial power systems. The proposed

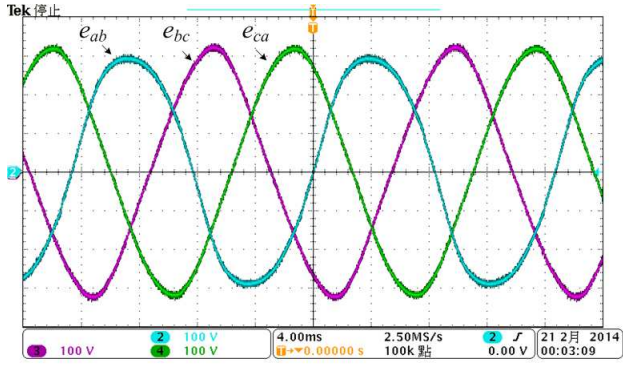

(a) Terminal voltage.

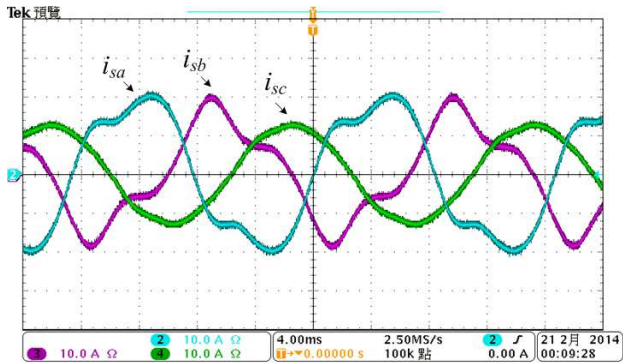

(b) Source current.

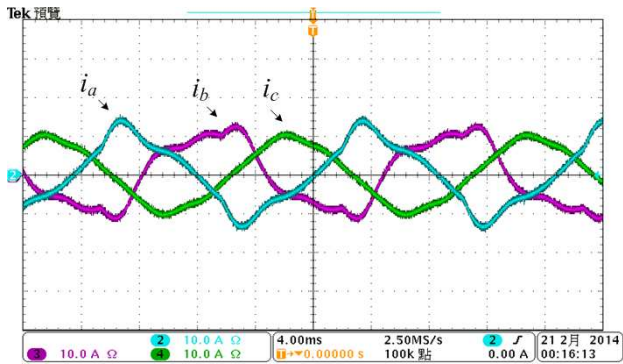

(c) Filter current.

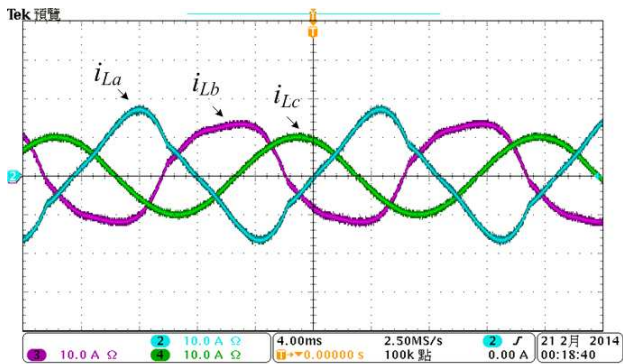

(d) Load current.

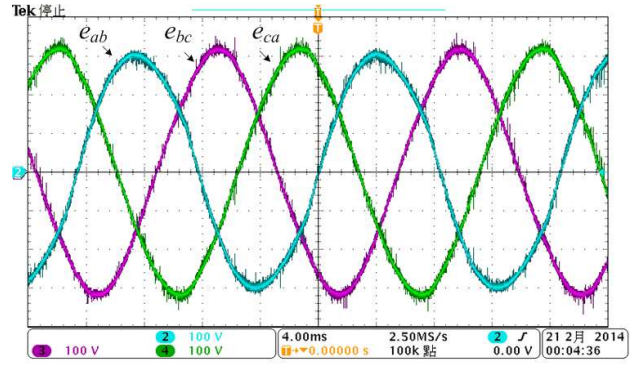

(a) Terminal voltage.

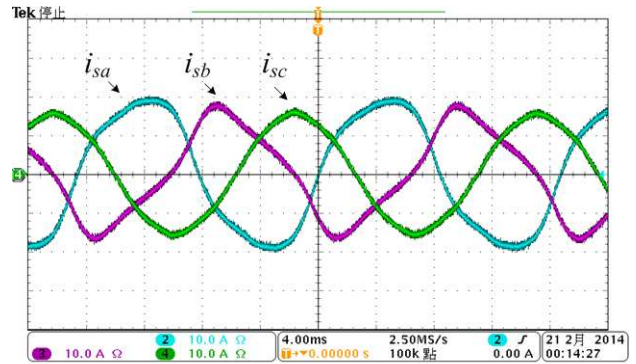

(b) Source current.

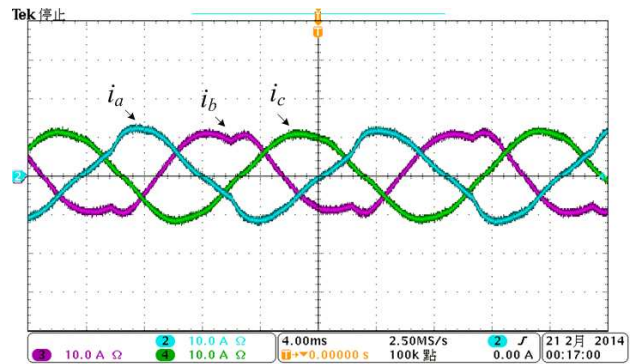

(c) Filter current.

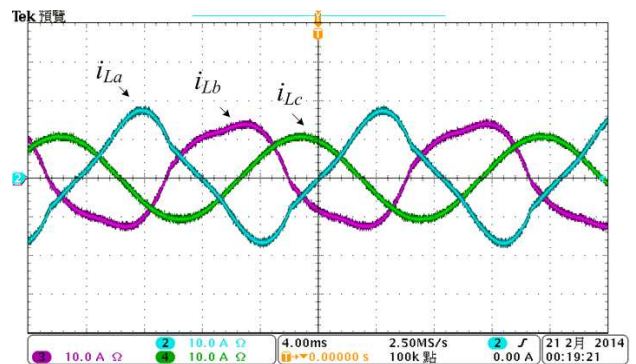

(d) Load current.

Fig. 13. The HAFU is off for single-phase nonlinear load.

Fig. 14. The HAFU is on for single-phase nonlinear load.

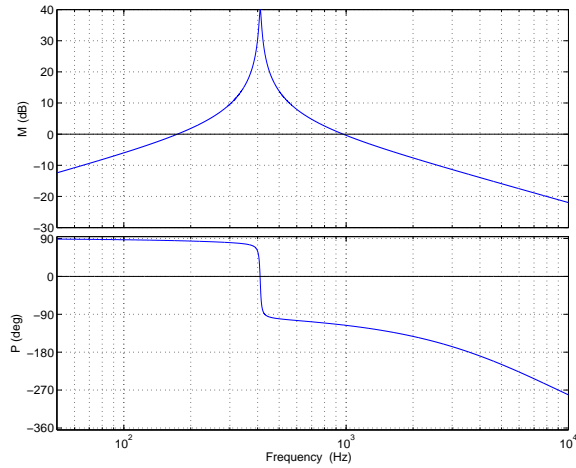

(a) Open-loop gain.

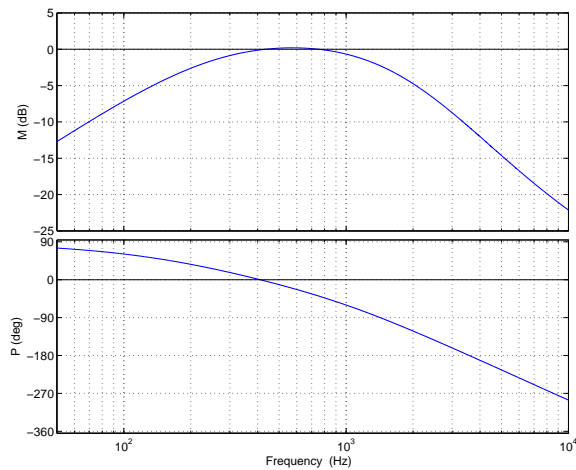

(b) Closed-loop gain.

Fig. 15. Frequency domain analysis of current control.

hybrid filter is composed of a seventh harmonic-tuned passive filter and an active filter in series connection at the secondary side of the distribution transformer. With the active filter part operating as variable harmonic conductance, the filtering performances of the passive filter can be significantly improved. Accordingly, the harmonic resonances can be avoided and the harmonic distortion can be maintained inside an acceptable level in case of load changes and variations of line impedance of the power system. Experimental results verify the effectiveness of the proposed method. Extended discussions are summarized as follows:

- Large line inductance and large nonlinear load may result in severe voltage distortion. The conductance is increased to maintain distortion to an acceptable level.
- Line resistance may help reduce voltage distortion. The conductance is decreased accordingly.
- For low line impedance, THD\* should be reduced to enhance filtering performances. In this situation, measuring

voltage distortion becomes a challenging issue.

- High-frequency resonances resulting from capacitive filters is possible to be suppressed by the proposed method.
- In case of unbalanced voltage, a band-rejected filter is needed to filter out second-order harmonics if the SRF is realized to extract voltage harmonics.

## REFERENCES

- [1] R. H. Simpson, "Misapplication of power capacitors in distribution systems with nonlinear loads—three case histories," *IEEE Trans. Ind. Appl.*, vol. 41, no. 1, pp. 134–143, Jan./Feb. 2005.
- [2] T. Dionise and V. Lorch, "Voltage distortion on an electrical distribution system," *IEEE Ind. Appl. Mag.*, pp. 48–55, Mar./Apr. 2010.
- [3] E. J. Currence, J. E. Plizga, and H. N. Nelson, "Harmonic resonance at a medium-sized industrial plant," *IEEE Trans. Ind. Appl.*, vol. 31, no. 3, pp. 682–690, May/Jun. 1995.
- [4] C.-J. Wu, J.-C. Chiang, S.-S. Yen, C.-J. Liao, J.-S. Yang, and T.-Y. Guo, "Investigation and mitigation of harmonic amplification problems caused by single-tuned filters," *IEEE Trans. Power Del.*, vol. 13, no. 3, pp. 800–806, July 1998.
- [5] B. Singh, K. Al-Haddad, and A. Chandra, "A review of active filters for power quality improvement," *IEEE Trans. Ind. Electron.*, vol. 46, no. 5, pp. 960–971, Oct. 1999.
- [6] H. Akagi, "Active harmonic filters," *Proc. IEEE*, vol. 93, no. 12, pp. 2128–2141, Dec. 2005.
- [7] A. Bhattacharya, C. Chakraborty, and S. Bhattacharya, "Shunt compensation," *IEEE Ind. Electron. Mag.*, pp. 38–49, Sept. 2009.
- [8] F. Z. Peng, "Application issues of active power filters," *IEEE Ind. Appl. Mag.*, pp. 21–30, Sep./Oct. 2001.
- [9] S. Bhattacharya and D. Divan, "Design and implementation of a hybrid series active filter system," in *IEEE 26th Annual Power Electronics Specialists Conference*, 1995, pp. 189–195.
- [10] S. Bhattacharya, P.-T. Cheng, and D. Divan, "Hybrid solutions for improving passive filter performance in high power applications," *IEEE Trans. Ind. Appl.*, vol. 33, no. 3, pp. 732–747, May/Jun. 1997.
- [11] H. Fujita, T. Yamasaki, and H. Akagi, "A hybrid active filter for damping of harmonic resonance in industrial power systems," *IEEE Trans. Power Electron.*, vol. 15, no. 2, pp. 215–222, Mar. 2000.
- [12] D. Detjen, J. Jacobs, R. W. De Doncker, and H.-G. Mall, "A new hybrid filter to dampen resonances and compensation harmonic currents in industrial power systems with power factor correction equipment," *IEEE Trans. Power Electron.*, vol. 16, no. 6, pp. 821–827, Nov. 2001.
- [13] V. Verma and B. Singh, "Design and implementation of a current-controlled parallel hybrid power filter," *IEEE Trans. Ind. Appl.*, vol. 45, no. 5, pp. 1910–1917, Sept./Oct. 2009.
- [14] H. Akagi, S. Sriathumrong, and Y. Tamai, "Comparison in circuit configuration and filtering performance between hybrid and pure shunt active filters," in *IEEE Industry Applications Conference 38th IAS Annual Meeting*, 2003, pp. 1195–1202.
- [15] C.-S. Lam, W.-H. Choi, M.-C. Wong, and Y.-D. Han, "Adaptive dc-link voltage-controlled hybrid active power filters for reactive power compensation," *IEEE Trans. Power Electron.*, vol. 27, no. 4, pp. 1758–1772, Apr. 2012.
- [16] A. Bhattacharya, C. Chakraborty, and S. Bhattacharya, "Parallel-connected shunt hybrid active power filters operating at different switching frequencies for improved performance," *IEEE Trans. Ind. Electron.*, vol. 59, no. 11, pp. 4007–4019, Nov. 2012.
- [17] S. Rahmani and K. Hamadi, A. and Al-Haddad, "A Lyapunov-function-based control for a three-phase shunt hybrid active filter," *IEEE Trans. Ind. Electron.*, vol. 59, no. 3, pp. 1418–1429, Mar. 2012.
- [18] S. Rahmani, A. Hamadi, K. Al-Haddad, and L. Dessaint, "A combination of shunt hybrid power filter and thyristor-controlled reactor for power quality," *IEEE Trans. Ind. Electron.*, vol. 61, no. 5, pp. 2152–2164, May 2014.
- [19] R. Inzunza and H. Akagi, "A 6.6-kV transformerless shunt hybrid active filter for installation on a power distribution system," *IEEE Trans. Power Electron.*, vol. 20, no. 4, pp. 893–900, July 2005.
- [20] P. Jintakosonwit, S. Sriathumrong, and P. Jintakosonwit, "Implementation and performance of an anti-resonance hybrid delta-connected capacitor bank for power factor correction," *IEEE Trans. Power Electron.*, vol. 22, no. 6, pp. 2543–2551, Nov. 2007.
- [21] K. Karanki, G. Geddada, M. Mishra, and B. Kumar, "A modified three-phase four-wire UPQC topology with reduced dc-link voltage rating," *IEEE Trans. Ind. Electron.*, vol. 60, no. 9, pp. 3555–3566, Sep. 2013.

- [22] A. Zobaa, "Optimal multiobjective design of hybrid active power filters considering a distorted environment," *IEEE Trans. Ind. Electron.*, vol. 61, no. 1, pp. 107–114, Jan. 2014.
- [23] T.-L. Lee, Y.-C. Wang, and J.-C. Li, "Design of a hybrid active filter for harmonics suppression in industrial facilities," in *IEEE Power Electronics and Drive Systems (PEDS)*, 2009, pp. 121–126.
- [24] T.-L. Lee, Y.-C. Wang, and J. Guerrero, "Resonant current regulation for transformerless hybrid active filter to suppress harmonic resonances in industrial power systems," in *IEEE Applied Power Electronics Conference and Exposition (APEC)*, 2010, pp. 380–386.
- [25] Y.-C. Wang and T.-L. Lee, "A control strategy of hybrid active filter to compensate unbalanced load in three-phase three-wire power system," in *IEEE Power Electronics for Distributed Generation Systems (PEDG)*, 2012, pp. 450–456.
- [26] T.-L. Lee, S.-H. Hu, and Y.-H. Chan, "D-STATCOM with positive-sequence admittance and negative-sequence conductance to mitigate voltage fluctuations in high-level penetration of distributed-generation systems," *IEEE Trans. Ind. Electron.*, vol. 60, no. 4, pp. 1417–1428, Apr. 2013.
- [27] V. Kaura and V. Blasko, "Operation of a phase locked loop system under distorted utility conditions," *IEEE Trans. Ind. Appl.*, vol. 33, no. 1, pp. 58–63, Jan./Feb. 1997.
- [28] P. Jintakosonwit, H. Akagi, H. Fujita, and S. Ogasawara, "Implementation and performance of automatic gain adjustment in a shunt active filter for harmonic damping throughout a power distribution system," *IEEE Trans. Power Electron.*, vol. 17, no. 3, pp. 438–447, Mar. 2002.
- [29] P. Jintakosonwit, H. Fujita, H. Akagi, and S. Ogasawara, "Implementation and performance of cooperative control of shunt active filters for harmonic damping throughout a power distribution system," *IEEE Trans. Ind. Appl.*, vol. 39, no. 2, pp. 556–564, Mar./Apr. 2003.
- [30] *IEEE Recommended practices and requirements for harmonic control in electrical power systems*, IEEE Std. 519-1992, 1993.
- [31] V. Blasko and V. Kaura, "A novel control to actively damp resonance in input LC filter of a three-phase voltage source converter," *IEEE Trans. Ind. Appl.*, vol. 33, no. 2, pp. 542–550, Mar./Apr. 1997.
- [32] P. C. Loh and D. G. Holmes, "Analysis of multiloop control strategies for LC/CL/LCL-filtered voltage-source and current-source inverters," *IEEE Trans. Ind. Appl.*, vol. 41, no. 2, pp. 644–654, Mar./Apr. 2005.
- [33] M. Liserre, F. Blaabjerg, and S. Hansen, "Design and control of an LCL-filter-based three-phase active rectifier," *IEEE Trans. Ind. Appl.*, vol. 41, no. 5, pp. 1281–1291, Sept./Oct. 2005.
- [34] E. Wu and P. W. Lehn, "Digital current control of a voltage source converter with active damping of LCL resonance," *IEEE Trans. Power Electron.*, vol. 21, no. 5, pp. 1364–1373, Sep. 2006.
- [35] Y. W. Li, "Control and resonance damping of voltage-source and current-source converters with LC filters," *IEEE Trans. Ind. Electron.*, vol. 56, no. 5, pp. 1511–1521, May 2009.
- [36] J. H. R. Enslin and P. J. M. Heskes, "Harmonic interaction between a large number of distributed power inverters and the distribution network," *IEEE Trans. Power Electron.*, vol. 19, no. 6, pp. 1586–1593, Nov. 2004.
- [37] A. V. Jouanne and B. Banerjee, "Assessment of voltage unbalance," *IEEE Trans. Power Del.*, vol. 16, no. 4, pp. 782–790, Oct. 2001.
- [38] P. Rodriguez, A. Luna, I. Candela, R. Mujal, R. Teodorescu, and F. Blaabjerg, "Multiresonant frequency-locked loop for grid synchronization of power converters under distorted grid conditions," *IEEE Trans. Ind. Electron.*, vol. 58, no. 1, pp. 127–138, Jan 2011.
- [39] (2010) Website of texas instruments. [Online]. Available: <http://www.ti.com/>
- [40] D. N. Zmood, D. G. Holmes, and G. H. Bode, "Frequency-domain analysis of three-phase linear current regulators," *IEEE Trans. Ind. Appl.*, vol. 37, no. 2, pp. 601–610, Mar./Apr. 2001.
- [41] M. Castilla, J. Miret, J. Matas, L. G. De Vicuna, and J. M. Guerrero, "Linear current control scheme with series resonant harmonic compensator for single-phase grid-connected photovoltaic inverters," *IEEE Trans. Ind. Electron.*, vol. 55, no. 7, pp. 2724–2733, July 2008.