



AALBORG UNIVERSITY
DENMARK

Aalborg Universitet

Experimental Study of Stable Surfaces for Anti-Slug Control in Multi-phase Flow

Pedersen, Simon; Løhndorf, Petar Durdevic; Yang, Zhenyu

Published in:

Proceedings of the 20th International Conference on Automation and Computing, ICAC 2014

DOI (link to publication from Publisher):

[10.1109/IConAC.2014.6935458](https://doi.org/10.1109/IConAC.2014.6935458)

Publication date:

2014

Document Version

Peer reviewed version

[Link to publication from Aalborg University](#)

Citation for published version (APA):

Pedersen, S., Løhndorf, P. D., & Yang, Z. (2014). Experimental Study of Stable Surfaces for Anti-Slug Control in Multi-phase Flow. In Proceedings of the 20th International Conference on Automation and Computing, ICAC 2014 (pp. 43-48). Cranfield : IEEE Press. DOI: 10.1109/IConAC.2014.6935458

General rights

Copyright and moral rights for the publications made accessible in the public portal are retained by the authors and/or other copyright owners and it is a condition of accessing publications that users recognise and abide by the legal requirements associated with these rights.

- ? Users may download and print one copy of any publication from the public portal for the purpose of private study or research.
- ? You may not further distribute the material or use it for any profit-making activity or commercial gain
- ? You may freely distribute the URL identifying the publication in the public portal ?

Take down policy

If you believe that this document breaches copyright please contact us at vbn@aub.aau.dk providing details, and we will remove access to the work immediately and investigate your claim.

Experimental Study of Stable Surfaces for Anti-Slug Control in Multi-phase Flow*

Simon Pedersen, Kasper Stampe, Sandra Lindberg Pedersen, Petar Durdevic and Zhenyu Yang

Department of Energy Technology,
Aalborg University

Esbjerg, Niels Bohrs Vej 8, 6700 Esbjerg, Denmark

E-mails: spe@et.aau.dk, kstamp10@student.aau.dk, slpe10@student.aau.dk, pdl@et.aau.dk, yang@et.aau.dk

Abstract – The severe slugging flow is always challenging in oil & gas production, especially for the current offshore based production. The slugging flow can cause a lot of potential problems, such as those relevant to production safety, fatigue as well as capability. As one typical phenomenon in multi-phase flow dynamics, the slug can be avoided or eliminated by proper facility design and control of operational conditions. Based on a testing facility which can emulate a pipeline-riser or a gas-lifted production well in a scaled-down manner, this paper experimentally studies the correlations of key operational parameters with severe slugging flows. These correlations are reflected through an obtained stable surface in the parameter space, which is a natural extension of the bifurcation plot. The maximal production opportunity without compromising the stability is also studied. Relevant studies have already showed that the capability, performance and efficiency of anti-slug control can be dramatically improved if these stable surfaces can be experimentally determined beforehand.

Keywords: Offshore, oil & gas, anti-slug, flow map, production-rate optimization

I. INTRODUCTION

To keep the production process safe and optimal is one of the main focus areas in the offshore oil & gas industry. Due to the harsh weather and ocean conditions, some unexpected operating conditions may happen, which can lead to undesired flow regimes in the production processes. One typical challenging issue is the slugging flow problem, and it could occur in any of the multi-phase flow segments; from the production well, through transport pipelines, to the riser segment before the fluids enter the first-stage separator. The slug directly causes varying flow rates and pressures in the system either periodically or semi-periodically, correspondingly the production rate will be significantly reduced with regards to the safety issues. Sometimes, these fluctuations can cause the system to emergently shut down. Furthermore, some typical consequences of having these oscillations consist of: liquid overflow and high pressure in the separators, overload on gas compressors, fatigue caused by repeating impact, high frictional pressure drop, low production, and production stop [1]. The elimination or reduction of severe slug in the offshore oil & gas production is therefore of big economic interest.

There are several different facility-based causes of slugging flow, where the riser-induced slug is a severe slug type. As shown in Fig. 1, the periodic slugging

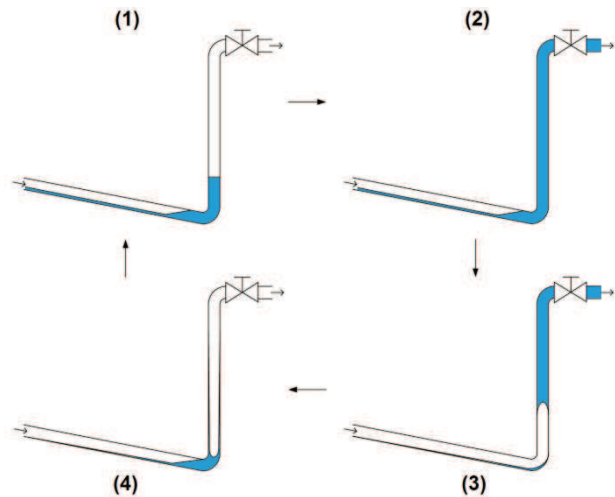

Figure 1. Illustration of the cyclic behavior in a riser pipeline when slug occurs [2].

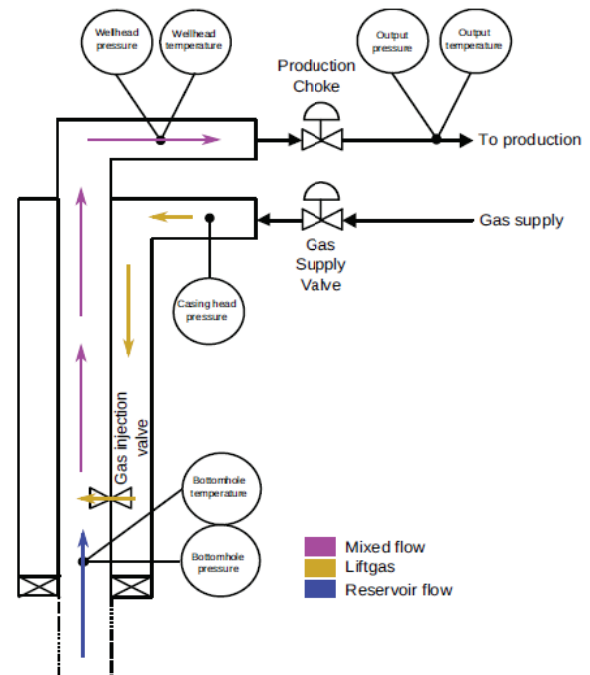

Figure 2. Illustration of a well with gas-lifting, pumping oil from a reservoir. Figure is from [3].

* Supported by the Danish National Advanced Technology Foundation through PDPWAC Project (J.nr. 95-2012-3).

behavior out of a vertical riser pipeline can be induced due to the following four stages: (1) Liquid firstly accumulates at the bottom of the riser due to different densities. (2) When more gas and liquid enter the system, the pressure increases and the bottom part of riser is blocked with liquid. (3) The following-up gas is blocked, and thereby the pressure is built up and at some point, the pressure is large enough to blow the liquid out of the riser. (4) After the blow-out, the liquid starts to build up at the bottom of the riser again, and the cycle repeats.

Similarly, the severe slug can happen in the production well, especially when the gas-lifting technique is used to promote the well's production rate. As shown in Fig. 2, in the gas-lifting well, two choke valves are often available for control purpose; one is at the (topside) outlet of the well head, and one is at the gas supply. The severe slug is formed when the casing head pressure is accumulating until it can overcome the hydrostatic pressure in the well riser and blow-out the liquid in the well riser.

From the control point of view, these induced slugs can potentially be eliminated by manipulating the choke valves, which will naturally change the operating condition and it is regarded as one of the most economic, easy and flexible anti-slug solutions. In a normal configuration, the pipeline-riser facility is equipped with one topside choke valve, while the well facility often equips with both a topside choke valve and a choke valve for the gas-lifting. It should be noticed that the gas-lifting technique can also be employed in a pipeline-riser construction.

The studies of anti-slug control by manipulating these choke valves can be found in many literatures in recent decades. Such as the control of a topside choke valve on the pipeline-riser construction with the knowledge of the bifurcation point of the choke valve opening is investigated in [4]; The stabilization casing-heading instability of gas-lift wells by using feedback control is discussed in [5]; The decreased production by the slug flow and developed control methods which both works for well- and pipeline-riser constructions using the pressure measurement at the bottom of the riser have been reported in [6]. An observer to estimate the bottom pressure from a topside pressure measurement is also developed in [6], due to the fact that the bottom pressure transmitter rarely is available in off-shore installations.

The work in this paper focuses on the exploration of quantitative correlation of key system's operational parameters with severe slugging flows in an experimental manner, such as to provide potential production optimization by the control of choke valves on a well-pipeline-riser construction. These correlations are reflected through a number of stable surfaces in the parameter space, which is a natural extension of the normal 2-D bifurcation plot. The maximal production opportunity without scarifying this stability is also studied. Relevant studies in [12] have already showed that the capability, performance and efficiency of anti-slug choke control can be dramatically improved if these stable surfaces can be determined beforehand.

The rest of the paper is organized in the following order: Section 2 introduces the lab-sized setup which generates the required analysis data; Section 3 describes the state-of-the-art flow and bifurcation mapping; Section 4 introduces a new mapping principle which combines the flow and bifurcation plots. Finally, a conclusion is carried out in section 5.

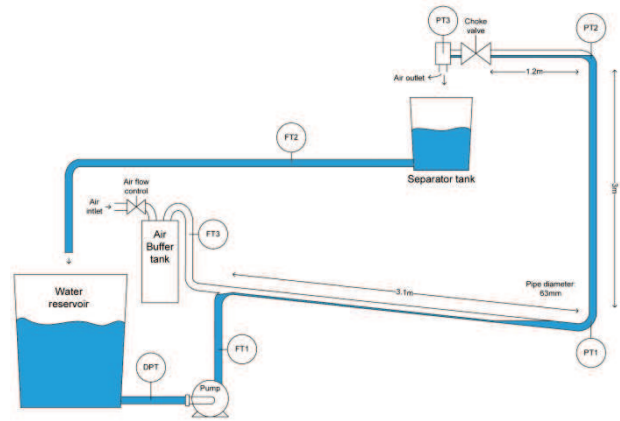

Figure 3. Diagram of the used lab-setup. Length of horizontal pipeline is 3.1 m, height of riser is 3 m, and length from riser to choke valve is 1.2 m. All pipe diameters are 6.3 cm [2].

II. LAB TESTING FACILITY

A lab-sized setup is built in order to study the slugging flow and its control [2-3]. The main objective of this facility is to emulate different flow patterns often happening at the offshore oil and gas production platforms. For instance, it can be properly configured to emulate a gas-lifting production well [3], or a pipeline-riser [2].

As shown in Fig. 3, this facility consists of horizontal and vertical pipes which simulate a real pipeline-riser system. Water is transported through the pipeline and riser to the choke valve and lead to the separator and back to the water reservoir to close the loop. Air is injected at the start of the pipeline, transported through the system and let out after the choke valve. The angle of the horizontal pipe can be adjusted from 0° to 20° , and the placement of the air injection can be moved from start of the pipeline to the bottom of the riser to emulate the gas-lifting well instead. The gas-injection is connected to a buffer tank to emulate a longer pipeline (for the pipeline-riser scenario) or the casing-heading volume (for the well scenario). More details for this setup can be found in [2-3].

III. FLOW AND BIFURCATION MAPS

Different flow patterns can be analyzed from empirical data operating at steady-state [7-8]. These flow maps indicate which flow pattern is represented in steady-state. The axes of the flow map are normally the superficial velocities of the gas and liquid, respectively. The superficial velocity is the volume flow rate over the area of the cross-section of the pipeline, which can be properly calculated based on the measured mass flow rate or directly measured by proper transmitters. The transmitters in this study are measuring mass flow rate, thus the

conversion equation from mass flow rate to superficial velocity is shown in equation 1.

$$\frac{\omega_{volume}}{A_{cross}} = \frac{\omega_{mass}}{\rho A_{cross}} = v$$

Where ρ is the density, ω_{mass} is the mass flow rate, ω_{volume} is the volume flow rate, and v is the superficial velocity.

As already mentioned the flow mapping requires experimental testing but these data are not always available, or sometimes transmitters are not available to provide the required measurement information. Thus a mathematical slug detection method is provided in [9] which has been a principle formulation in the current oil & gas industry, and it is referred to as ‘‘Boe Criterion’’. Similar work is found in [10], where another criterion, which was successfully verified against experimental data, is also provided. These mathematical equations can be used to estimate an approximate the flow map surface.

To evaluate the topside choke valve’s influence on the system a bifurcation map can be carried out. The Hopf bifurcation occurs in a dynamic system, when the system losses stability due to changes in an independent variable [11], in this system the choke valve opening. For the well or riser-pipeline system, Hopf bifurcation can occur if a change of the valve opening causes the system to become unstable (slug) at an operating point, called the bifurcation point. [3] carried out a bifurcation plot for the emulation of the well using the lab testing facility, see figure 4. It is observed that the plot contains 4 independent bifurcation maps, each with a different gas injection which is emulating the gas-lifting. At the bifurcation point of each mapping the graph divides into two separate lines, indicating a steady pressure changing to an oscillating pressure where the top graph is the maximum pressure and the low graph is the minimum pressure of one slug cycle. It was observed that the bifurcation mapping heavily depends on the gas-lifting, thus a plot of the bifurcation map without considering the gas-lifting will be inaccurate.

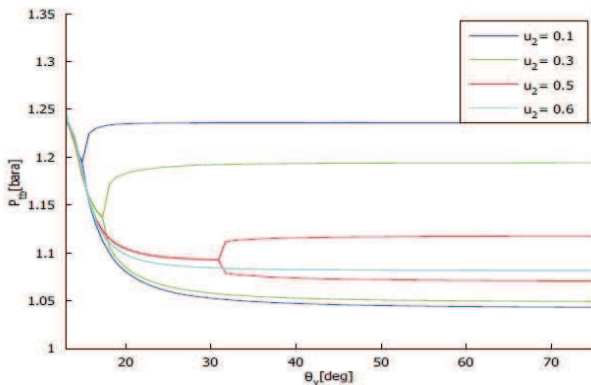

Figure 4. 4 bifurcation maps, under four different gas-lifting scenarios. Figure is from [3]

A similar experiment has been carried out for the flow map of the well, also emulated by the lab testing facility with different choke valve openings, z , see figure 5. The

figure shows that the region mapping of the slugging heavily depends on the choke valve opening. Hence the flow map can only be plotted with a fixed choke valve opening as this is considered being constant in the flow map. The effect of a change in choke valve however reveals to have big influence on the flow map regions.

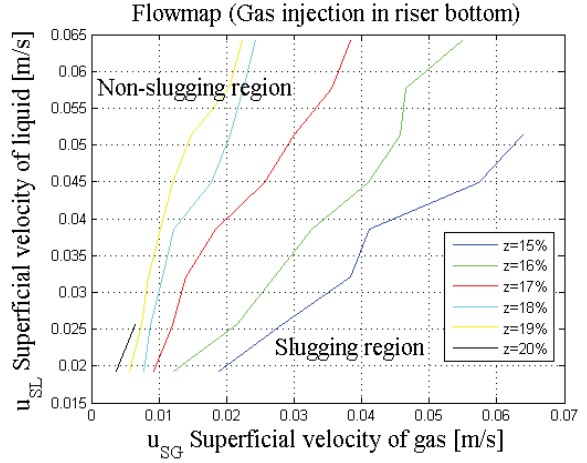

Figure 5. A flow map of the well emulated on the testing facility. It is observed that the mapping heavily depends on the choke valve opening percentage, z .

For a controller it is important to know which region has proven to eliminate the slug, as this will be the controller’s boundaries. Thus it is important to have a correlated map of both the flow and bifurcation map of the considered system. This will be useful for the overview of the system and can be used to optimize the performance of controllers. The settling time of the implemented controller developed in [12] has proven to be reduced dramatically with the knowledge of both the flow maps and the bifurcation maps, hence a better picture of the mapping can both improve the transient performance while also give more precision on the optimal input value to aim with.

In section IV a new 4D-picture will be studied as this will give the combined picture of both the bifurcation and flow maps.

IV. BOUNDARY SURFACES FOR STABLE FLOWS

The correlation between the flow mapping and the Hopf bifurcation mapping of the choke valve is being carried out by tests on the lab testing facility described in section II.

The first test made is considering the well emulation with a constant liquid injection, but with changing the gas-injection and the topside choke valve opening. The test is illustrated in figure 6. The test results are plotted as the big dots indicated either a stable or unstable (slug) flow. The test result is compared to the Boe Criterion, which is showing close to the same results, but as the gas injection gets bigger or with small opening degrees, Boe Criterion begins to be inaccurate to the real observations. This is the motivation to not solely rely on the state-of-the-art mathematical detection methods, but also use the experimental data to achieve the bifurcation points.

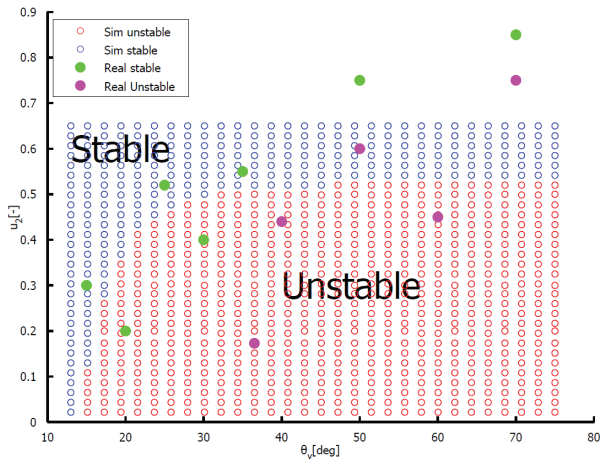

Figure 6. A gas-lift and opening degree mapping of the stable and unstable regions. Boe Criterion is used and compared to real data.

The mapping in figure 6 is limited by only having a single constant liquid injection, thus the mapping cannot easily be implemented in a control scheme in reality where the oil and water pumped from the reservoir often vary. Besides, the pressure or flow is not being considered as the flow maps only indicate what flow pattern is occurring under which running conditions as a Boolean. In reality the slugs will be of a more or less severe kind, as well as the stable flow can minimize the production if the back pressure is increased too much. Hence there exist several good reasons to also consider the pressure.

3D surface separating stable and unstable regions (Non-Slug)

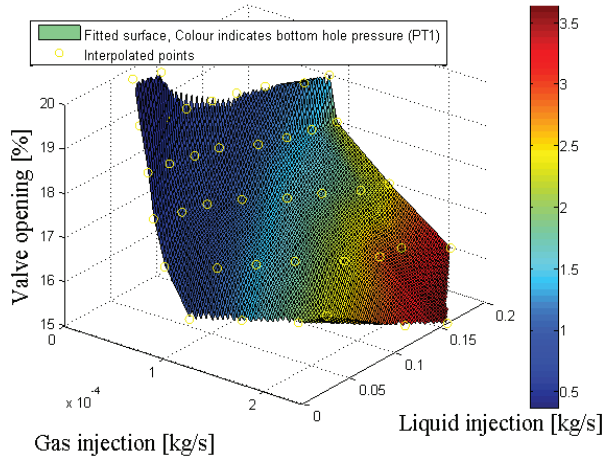

Figure 7. A 3D-plane of the combined flow and bifurcation map. The surface is indicating the plane where stable flow switches to slug flow and the color is indicating the pressure in the bottom of the riser.

Figure 7 is the new proposed 4D-picture of the emulated well, where the 3 axes are the gas mass flow rate, the liquid mass flow rate, and the choke valve opening percentage. As the visualization map is limited to 3D the color is indicating the last dimension, the average pressure in the bottom of the riser, PT1. The 3D surface is indicating bifurcation point of the region where the stable flow switches to the slug flow pattern. The pressure is measured from the last point where the stable flow pattern occurs, before the slugging occurs. By the use of this 4D-map, the systems flow pattern can be observed no matter

which running conditions are acting on the system, as well as the back pressure under a given working area. However, the bottom pressure itself cannot be used as an evaluation parameter for the optimal working area for a control scheme, as a pressure increase also can be caused by an increase in the production rate.

3D surface separating stable and unstable regions (Non-Slug)

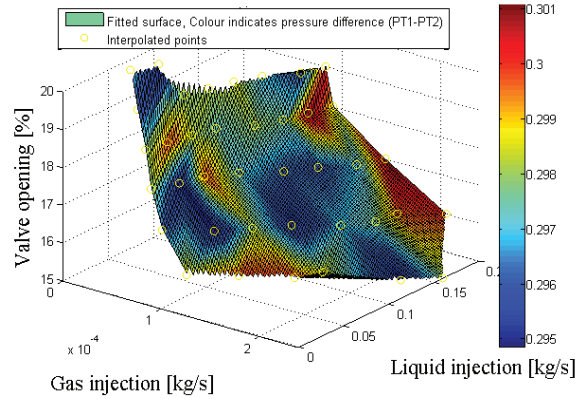

Figure 8. A 3D-plane of the combined flow and bifurcation map. The surface is indicating the plane where stable flow switches to slug flow and the color is indicating the pressure difference over the riser.

The 4D-picture in figure 8 is similar to the plane in figure 7, but now the color is indicating the average pressure difference over the riser; from the topside choke valve, PT2, to the bottom hole, PT1. The same data set is being used as the test in figure 7. The pressure difference over the riser is equivalent to the production rate in the riser. As the main objective of the controller is to eliminate the slug and meanwhile maximize the production, this 4D-map can be used to find the optimal operation point of both the gas-lifting and the control valve. Besides, with an approximate knowledge of the liquid injection from the well, it is now possible to design a robust boundary, where the surface will not be crossed, hence avoid the slugging flow.

3D surface separating stable and unstable regions (Slug)

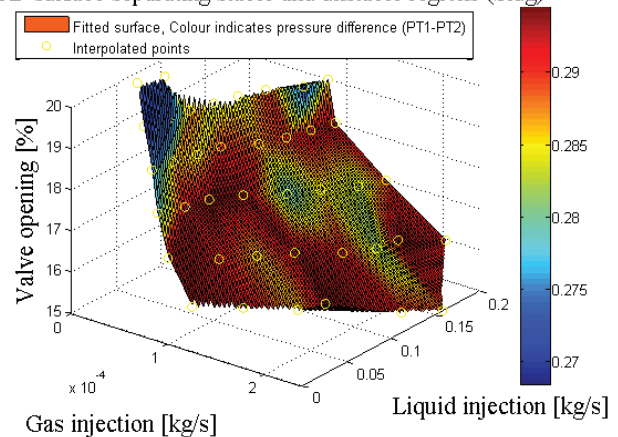

Figure 9. A 3D-plane of the combined flow and bifurcation map. The surface is indicating the plane where stable flow switches to slug flow and the color is indicating the pressure difference over the riser in the slugging region measurement closest to the surface.

The same plane is being used once again to prove that the slug will reduce the production. Figure 9 shows the

same surface from the same data set, but now the color is indicating the pressure difference over the riser for the slugging region measurement closest to the surface. It is clear that the pressure difference in the entire slugging region is smaller than the stable region. For this reason the slug region will be avoided, thus being used as boundaries for a possible control scheme.

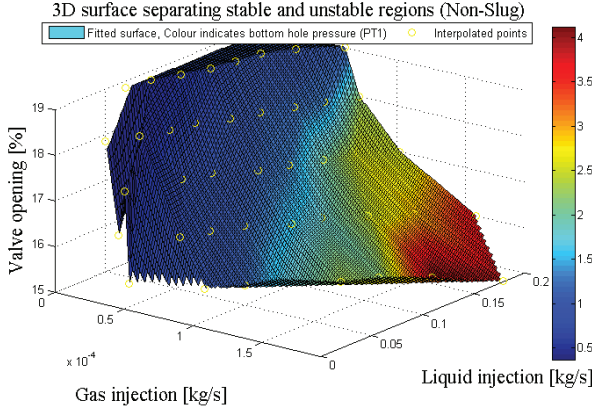

Figure 10. A 3D-plane of the combined flow and bifurcation map of the pipeline-riser system, where the color indicates the bottom pressure.

When the surface is used to control the well in an optimal way, the injection knowledge is also known for the pipeline-riser system, which typically is connected to the outlet of the well. As both the pressure difference and gas injection for the gas-lifting are known, this can be used to estimate the injection into pipeline-riser facility. As the horizontal pipeline length here can be many kilometers the volume can possibly be much bigger than the casing-heading, and the angled connection from the horizontal pipeline at the subsea to the riser can take many different shapes, thus the surface indicating the slug region of the pipeline-riser will be slightly different from the well's 4D-picture. Figure 10 shows the 4D-surface for the emulated pipeline-riser at the lab testing facility. The surface color is indicating the bottom pressure, PT1. Here both liquid and gas is being injected at the beginning of the pipeline, and not at the bottom of the riser as in the well emulation. The figure surface is showing similarities to the well emulation, but still varies in term of pressure amplitude and surface shape. This is caused by the pipeline angled to the riser connection, where the gas can accumulate over a bigger volume of the pipeline when the slug occurs. This also means that the bigger volume possibly can create more severe slugs as the riser height is the same for both emulations.

To evaluate the production of the pipeline-riser surface, the average pressure difference over the riser is once again being used, see figure 11. The figure shows that the pressure difference at the entire plane is not varying much, however reaching a proper working area on the surface can still improve the pressure difference by up to 5% according to the 4D-picture. As the pressure difference is equivalent to the production, this increase can result in a high production increase, just by using proper boundaries. It also proves that since the gas and liquid injections are partially controllable because of the well connection, the cooperation between the two subsystems can improve the overall performance.

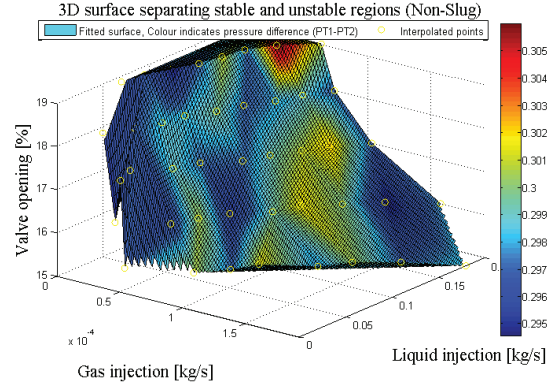

Figure 11. A 3D-plane of the combined flow and bifurcation map of the pipeline-riser system, where the color indicates the pressure difference over the riser.

As for the well the 4D-mapping of the pipeline-riser has been compared to the pressure of the slugging region next to the surface, see figure 12. Once again the figure proves that the slug pattern heavily reduces the production. Thus the slug region has to be avoided at first priority, as it can damage the process, but also reduce the production of the process.

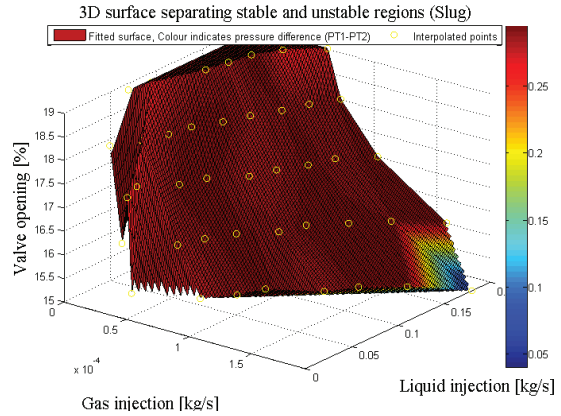

Figure 12. A 3D-plane of the combined flow and bifurcation map of the pipeline-riser system, where the color indicates the pressure difference over the riser under the slug flow next to the surface.

Both the well and pipeline-riser 4D-surfaces are showing a big production increase potential by using the right boundaries, as well as a clear picture of where the slug regions are placed. Thus the 4D-surfaces can be used for future control schemes, no matter which of the two subsystems you are considering. It is also shown from figure 9 and 12 that the slug reduces the production, hence it is important not to cross the 4D-surface into the slug region, and with the proposed 4D-mapping this surface is available.

V. CONCLUSION AND FUTURE WORK

In this paper the study of slug flow has been investigated. Traditionally flow maps and bifurcation maps are being used to understand the performance of the flow patterns in the systems. These maps, however, have the limitations of being correlated and for this reason a new 4D-picture is being examined to get a more clear overall picture of the system's performance. The 4D-picture is being visualized with a 3D-surface of the three

parameters: Gas flow, Liquid flow, and Valve opening. The surface indicates the bifurcation point at which the stable flow changes to unstable flow. Besides, the color of the surface can indicate either the pressure or flow under the given running conditions. The maps are being carried out by tests from a lab testing facility constructed by [2] and [3]. The experiments prove the importance of the clear system picture as this can both improve the performance of the system by knowing the control input boundaries for the highest production, and give robustness to a controller, as the surface indicating the slug region can be avoided by having the knowledge of the 4D-map.

For a real system, where data for the 4D-map is not available, simulation tools such as OLGA or LedaFlow can be used to simulate the system's behaviour and hence obtaining the stable surfaces from these simulations. The simulation tools are validated on other testing facilities. As there might be some deviation between these facilities and a real platform, the stable surfaces might also deviate from reality. However this is the best option without having the possibility to test on a real system.

In the 4D-graphs presented in this study the color of the stable surfaces is indicating different pressure measurements. Obviously this can be changed to any measurement available, however the pressure measurement for real pipeline systems is the most commonly used measurement method. Hence the color could also indicate other system behaviours such as the slugging frequency. This possible extension gives the presented visualization many different development opportunities in the future.

For future work the extension of test with the pipeline-riser with gas-lifting could be considered. This would add an additional degree of freedom to the control scheme. However, the gas-lifting is often not available at this point, hence not useful for all platforms. Using the knowledge of the 4D-map will in the future be tested with control schemes developed for the lab testing facility to evaluate the performance of a controller using the 4D-surface as the boundaries of the controller.

ACKNOWLEDGMENT

The authors would like to thank Rambøll Oil & Gas A/S, and Maersk Oil A/S, for technical and equipment supports.

REFERENCES

[1] Hill, T.J. and Wood, D.G. (1994). Slug flow: Occurrence, consequences, and prediction. University of Tulsa Centennial Petroleum Engineering Symposium.

[2] Bilotft, J., Hansen, L., Pedersen, S., and Yang, Z. (2013). Recreating riser slugging flow based on an economic lab-sized setup. IFAC International Workshop on Periodic Control, 5th, 47-52.

[3] Kasper Jepsen, Leif Hansen, Christian Mai and Zhenyu Yang (2013). Emulation and Control of Slugging Flows in a Gas-Lifted Offshore Oil Production Well Through a Lab-sized Facility. 2013 IEEE Multi-conference on Systems and Control. Hyderabad, India, August 28-30, 2013

[4] Ogazi A. Isaac, Yi Cao, Liyun Lao and Hoi Yeung (2011). Production Potential of Severe Slugging Control Systems. 18th IFAC World Congress (2011).

[5] Gisle Otto Eikrem (2006), Stabilization of Gas-Lift Wells by Feedback Control. PhD thesis (May 4th 2006), Norwegian University of Science and Technology.

[6] Meglio, Petit, Alstad, Kaasa (2012). Stabilization of slugging in oil production facilities with or without upstream pressure sensors. Journal of Process Control 22 (2012), 809– 822

[7] Hewitt, G.F. and Roberts, D.N. (1969). Studies of Two-Phase Flow Patterns by Simultaneous X-Ray and Flash Photography. Defense Technical Information Center.

[8] Li, N., Guo, L., and Li, W. (2013). Gas-liquid two-phase flow patterns in a pipeline riser system with an s-shaped riser. International Journal of Multiphase Flow, 55, 10.

[9] Boe, A. (1981). Severe slugging characteristics. Course in Two Phase Flow, NTH, Trondheim, Norway.

[10] F. E. Jansen, O. Shoham, Y.T. (1996). The elimination of severe slugging - experiments and modeling. Int. J. Multiphase Flow, 22, 1055-1072.

[11] Thompson, J.M.T. and Stewart, H.B. (1986). Nonlinear Dynamics and Chaos. John Wiley and Sons Ltd, Chichester Great Britain, 1st edition.

[12] Simon Pedersen, Petar Durdevic, and Zhenyu Yang (2014). Learning control for riser-slug elimination and production-rate optimization for an offshore oil and gas production process. IFAC 2014: The 19th IFAC World Congress.