



Aalborg Universitet

AALBORG UNIVERSITY  
DENMARK

## A Learning Based Precool Algorithm for Utilization of Foodstuff as Thermal Energy Storage

Vinther, Kasper; Rasmussen, Henrik; Izadi-Zamanabadi, Roozbeh; Stoustrup, Jakob; Alleyne, Andrew G.

*Published in:*

2013 IEEE International Conference on Control Applications (CCA)

*DOI (link to publication from Publisher):*

[10.1109/CCA.2013.6662777](https://doi.org/10.1109/CCA.2013.6662777)

*Publication date:*

2013

*Document Version*

Early version, also known as pre-print

[Link to publication from Aalborg University](#)

*Citation for published version (APA):*

Vinther, K., Rasmussen, H., Izadi-Zamanabadi, R., Stoustrup, J., & Alleyne, A. G. (2013). A Learning Based Precool Algorithm for Utilization of Foodstuff as Thermal Energy Storage. In 2013 IEEE International Conference on Control Applications (CCA) (pp. 314-321). IEEE. (IEEE International Conference on Control Applications). DOI: 10.1109/CCA.2013.6662777

### General rights

Copyright and moral rights for the publications made accessible in the public portal are retained by the authors and/or other copyright owners and it is a condition of accessing publications that users recognise and abide by the legal requirements associated with these rights.

- ? Users may download and print one copy of any publication from the public portal for the purpose of private study or research.
- ? You may not further distribute the material or use it for any profit-making activity or commercial gain
- ? You may freely distribute the URL identifying the publication in the public portal ?

### Take down policy

If you believe that this document breaches copyright please contact us at [vbn@aub.aau.dk](mailto:vbn@aub.aau.dk) providing details, and we will remove access to the work immediately and investigate your claim.

# A Learning Based Precool Algorithm for Utilization of Foodstuff as Thermal Energy Storage

Kasper Vinther<sup>1</sup>, Henrik Rasmussen<sup>1</sup>, Roozbeh Izadi-Zamanabadi<sup>1,2</sup>, Jakob Stoustrup<sup>1</sup>, and Andrew G. Alleyne<sup>3</sup>

**Abstract**—Maintaining foodstuff within predefined temperature thresholds is important due to legislative requirements and to sustain high foodstuff quality. This is achieved using a refrigeration system. However, these systems might not be dimensioned for hot summer days or possible component performance degradation. A learning based algorithm is proposed in this paper, which precools the foodstuff in an anticipatory manner based on the saturation level in the system on recent days. The method is evaluated using a simulation model of a supermarket refrigeration system and simulations show that thermal energy can be stored in foodstuff to cope with saturation in refrigeration equipment. Additional hardware or a system model is not required, making it easy to implement the method in existing systems.

## I. INTRODUCTION

Cooling equipment is installed in many places to preserve foodstuff/goods and to maintain room temperatures within desired bounds on hot days. Usually foodstuff must be maintained at temperatures determined by legislative requirements and divergence of room temperatures from a set point leads to discomfort for occupants. Saturation in the cooling equipment can result in violation of the predefined temperature bounds and can occur if e.g. the installed system is too small to deal with very hot outside temperatures, if a component fails (e.g. a compressor in a compressor rack), if the refrigerant charge in the system changes, or due to component wear leading to degradation of performance.

Sizing up equipment in order to have spare capacity to deal with any thinkable outside temperature and possible component malfunction is costly. Also, more extreme weather due to global warming could make a perfectly sized system inadequate in the future. Finally, higher peak power demand is costly and could require expansion of transmission lines and transformers for large systems such as supermarket refrigeration systems, warehouses, and office buildings. Thermal storage tanks could be installed to overcome this problem and to utilize changes in utility price, which provides the possibility of shifting loads to off peak hours where energy is cheaper and outside temperatures are lower.

In [1], [2], [3], [4], to reference a few, building thermal capacity and/or thermal storage tanks are used to store energy for later use. However, adding a thermal storage tank adds an additional capital investment.

Research has also been invested in precooling of foodstuff and the use of foodstuff as thermal storage. Load shifting strategies are investigated for four different low temperature warehouses in [5], where the authors show significant cost savings, possible due to the relatively large thermal capacity of these buildings and the large quantity of foodstuff. The use of Model Predictive Control (MPC) for precooling of foodstuff in supermarkets is investigated in [6] and [7]. They showed the potential of storing energy in the individual display cases in order to cope with high loads on hot summer days, but also to provide ancillary services to the Smart Grid. Furthermore, [6] and [8] have looked at food quality loss as a function of temperature and the thermal storage potential of different foodstuffs.

All references, known to the authors, either use a MPC approach, due to its ability to handle constraints, or just a predefined schedule. However, deriving a suitable model and parameters for prediction purposes can be cumbersome and costly, especially since each refrigeration system is often composed of different components and has different sizes. As with the heuristically chosen schedule, a model based MPC approach is often tailored to a specific system and lack modularity, flexibility, and robustness towards changes. These changes can be large changes in operating conditions, changes in load patterns, changes in system parameters due to e.g. component wear or reduction in refrigerant charge, and faulty components. Furthermore, the amount and type of foodstuff changes the storage capacity for each individual display case and could change during the year.

Instead, we have investigated the possibility of using a learning based control method to precool, with the objective of reducing the risk of having to discard refrigerated foodstuff on hot days due to system saturation, which can be very costly. A certain amount of precooling might even be favorable cost-wise when the system is not saturated, because energy consumption can be shifted to a time with lower outdoor temperature and energy price. However, there will also be a higher heat loss from the precooled foodstuff and the general practice today is not to precool. This paper therefore only considers avoiding system saturation.

Iterative Learning Control (ILC) and Repetitive Control (RC) are two examples of learning based control, see e.g.

<sup>1</sup>K. Vinther, H. Rasmussen, R. Izadi-Zamanabadi and J. Stoustrup are with the Section of Automation and Control, Department of Electronic Systems, Aalborg University, 9220, Denmark {kv,hr,riz,jakob}@es.aau.dk

<sup>2</sup>R. Izadi-Zamanabadi is also with the Department of Electronic Control and Services, Danfoss A/S, 6430, Denmark roozbeh@danfoss.com

<sup>3</sup>A. G. Alleyne is with the Department of Mechanical Science and Engineering, University of Illinois, Urbana, IL - 61801, USA alleyne@illinois.edu

[9], [10], [11] for more details. These methods are often used in batch processes where the same task is repeated, which makes it possible to learn a performance improving feedforward signal or a reference modifying signal for the next repetition of the same task referred to as a trial (see parallel and serial ILC in [10]). The relation to refrigeration systems is that there is a certain amount of repeatability on a daily basis, e.g. a good estimate of the weather tomorrow is the weather today and the load from customers in a supermarket or occupants in an office will also be similar. The repeatability can be checked by calculating the repeatable-to-nonrepeatable ratio for different frequencies as done in e.g. [12], [13]. However, this is not included in this paper.

Changing the reference signal to force the refrigeration system to precool when the system is already saturated does not help. An optimization based constrained ILC is proposed in [14] to handle constrained linear systems. However, this method does not try to reduce the saturation by precooling, it only ensured that the ILC converges. In this paper we propose a precool algorithm inspired by ILC, which learns how much precool is needed and when it is needed based on previous experience and does not require extra hardware or system model knowledge as MPC. The method is tested on a realistic simulation model of a supermarket refrigeration system, where it is possible to change the air temperature thresholds for the display cases controlled by on/off relay feedback on the refrigerant inlet valve. In other words, precooling is performed by lowering the temperature thresholds for a while. This also ensures that we will never precool the foodstuff to a temperature lower than what we allow.

The paper is organized in the following way. Section II describes the learning based precool algorithm and provides a simple simulation example. A simulation model of a supermarket refrigeration system is then presented in Section III. Automatic tuning procedures for refrigeration systems are then provided in Section IV followed by simulation results without precooling, with constant precooling and with the proposed precool algorithm in Section V. Finally, conclusions are drawn in Section VI.

## II. LEARNING BASED PRECOOL ALGORITHM

We have a system controlled with the relay feedback

$$u(k) = \begin{cases} \bar{u} & \text{if } y(k) > \bar{y}(k) \\ \underline{u} & \text{if } y(k) < \underline{y}(k) \\ u(k-1) & \text{otherwise,} \end{cases} \quad (1)$$

where  $u(k)$  is the control input at time  $k$  in the discrete time domain taking the value  $\bar{u}$  if the system output  $y(k)$  reaches an upper threshold  $\bar{y}(k)$  and  $\underline{u}$  if the output reaches a lower threshold  $\underline{y}(k)$ . This is a very simple controller and also a widely used method of maintaining the temperature of a medium within predefined bounds.

We will in the following assume that both thresholds can be modified by a learning controller, which at the end of each trial updates a vector of threshold modifying values to be used in the next trial allowing us to precool if necessary.

The threshold vectors are given as

$$\bar{\mathbf{y}}_j = \bar{\mathbf{y}}_o + \bar{\mathbf{y}}_{m,j} \quad (2)$$

$$\underline{\mathbf{y}}_j = \underline{\mathbf{y}}_o + \underline{\mathbf{y}}_{m,j}, \quad (3)$$

where  $\bar{\mathbf{y}}_o$  and  $\underline{\mathbf{y}}_o$  are the initial time invariant thresholds and  $\bar{\mathbf{y}}_{m,j}$  and  $\underline{\mathbf{y}}_{m,j}$  are the threshold modifying vectors for the trial denoted by  $j$ . The modifiers are generated based on the length of the current precool period  $\Delta_j$  and the specified end time for the precool period  $t_{end}$ . For simplicity it is assumed that each  $y_m(k)$  can only take the value 0 (do not precool) or  $\alpha$  (precool) and that the end time  $t_{end}$  is chosen manually. An automatic way of determining  $t_{end}$  for each trial is proposed later in Section IV. The controlled system in the trial domain is shown in Fig. 1.

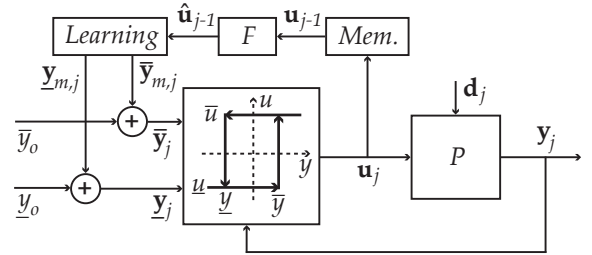

Fig. 1. Trial domain representation of a relay feedback controlled system  $P$  with learning based adaptation of the thresholds.

The length of the precool period at trial  $j$  is determined based on an ILC inspired learning algorithm given as

$$\Delta_j = \Delta_{j-1} + \delta_{j-1}, \quad (4)$$

where  $\Delta_{j-1}$  is the length of the previous precool period and  $\delta_{j-1}$  is the update. This update is determined by

$$\delta_{j-1} = \begin{cases} k_1 \bar{\Delta} & \text{if } \|\hat{\mathbf{u}}_{j-1}\|_\infty \geq \bar{u} \\ k_2 \bar{\Delta} & \text{otherwise,} \end{cases} \quad (5)$$

where  $\hat{\mathbf{u}}_{j-1}$  is the estimated capacity of the control input (or duty cycle) during the previous trial  $j-1$  and  $\bar{u}$  is a threshold that indicates if precooling is needed or not.  $k_1$  and  $k_2$  are the learning and de-learning gains, respectively. A gain  $k_1 < 1$  means that the full precool period  $\bar{\Delta}$  (maximum allowed precool time) is not reached in one trial and low values gives slower convergence.

The estimated capacity  $\hat{\mathbf{u}}_{j-1}$  can be calculated by filtering the control input;

$$\hat{\mathbf{u}}_{j-1} = F \mathbf{u}_{j-1}, \quad (6)$$

where  $F$  can be a zero phase low pass filter that provides a mean value or duty cycle of the on/off based input vector  $\mathbf{u}_{j-1}$  during the previous trial.

If the system output settles between the new modified thresholds within the precool period, then it does not make sense to extend the precool period anymore, as it will only increase the power consumption. The precool period is therefore limited by a predefined maximum length  $\bar{\Delta}$ ;

$$\Delta_j = \begin{cases} \bar{\Delta} & \text{if } \Delta_j > \bar{\Delta} \\ 0 & \text{if } \Delta_j < 0 \\ \Delta_j & \text{otherwise.} \end{cases} \quad (7)$$

The maximum length should depend on the storage potential of the system and is therefore further treated in Section IV.

In the serial ILC the error in the previous trial is used to update the reference. The proposed precool algorithm instead uses the saturation level of the input to determine how long to precool the system and consequently how much energy to store in the system before the saturation.

### A. Simple Thermal Storage Example

The learning based precool algorithm is demonstrated using a simple thermal storage example. Assume that the temperature  $T_{goods}$  of a lumped mass of foodstuff has to be controlled indirectly by controlling the heat transfer rate  $\dot{Q}_e$  out of an air volume surrounding the foodstuff.  $\dot{Q}_e$  is controlled with relay feedback between  $\bar{\dot{Q}}_e$  if the air temperature  $T_{air} < 2^\circ C$  and  $\bar{\dot{Q}}_e$  if  $T_{air} > 5^\circ C$ . The load on the system  $\dot{Q}_{amb-air}$  is a square signal which repeats itself on a daily basis and has a maximum value above  $\bar{\dot{Q}}_e$ . This means that the system goes into saturation and the temperature of the foodstuff will go above  $5^\circ C$  if energy in the form of coldness is not stored in the foodstuff before the saturation occurs.

The system is illustrated in Fig. 2. The governing differ-

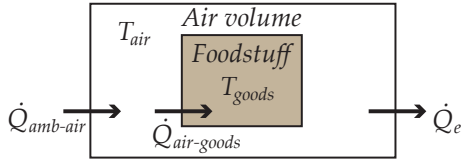

Fig. 2. Example system with goods surrounded by an air volume. The controllable input to the system is the heat transfer rate out of the system  $\dot{Q}_e$  and the disturbance load is the heat transfer rate into the system  $\dot{Q}_{amb-air}$ .

ential equations for the temperature of the goods  $T_{goods}$  and the air  $T_{air}$  are

$$\frac{dT_{goods}}{dt} = \frac{\dot{Q}_{air-goods}}{m_{goods}C_{p,goods}}, \quad (8)$$

$$\frac{dT_{air}}{dt} = \frac{\dot{Q}_{amb-air} - \dot{Q}_{air-goods} - \dot{Q}_e}{m_{air}C_{p,air}}, \quad (9)$$

$$\dot{Q}_{air-goods} = UA_{air-goods}(T_{air} - T_{goods}) \quad (10)$$

where  $UA_{air-goods}$  is the overall heat transfer coefficient between the air and the goods,  $m_{air}$  is the mass of the air,  $m_{goods}$  is the mass of goods,  $C_{p,air}$  is the specific heat of the air, and  $C_{p,goods}$  is the specific heat of the goods. These equations can be formulated in state space as

$$\begin{bmatrix} \dot{T}_{air} \\ \dot{T}_{goods} \end{bmatrix} = \begin{bmatrix} \frac{-UA_{air-goods}}{m_{air}C_{p,air}} & \frac{UA_{air-goods}}{m_{air}C_{p,air}} \\ \frac{UA_{air-goods}}{m_{goods}C_{p,goods}} & \frac{-UA_{air-goods}}{m_{goods}C_{p,goods}} \end{bmatrix} \begin{bmatrix} T_{air} \\ T_{goods} \end{bmatrix} + \begin{bmatrix} \frac{-1}{m_{air}C_{p,air}} \\ 0 \end{bmatrix} \dot{Q}_e + \begin{bmatrix} \frac{1}{m_{air}C_{p,air}} \\ 0 \end{bmatrix} \dot{Q}_{amb-air}. \quad (11)$$

For simplicity the load  $\dot{Q}_{amb-air}$  is assumed to be state independent. However, in a more elaborate model it should be a function of the temperature difference between the ambient and the air. Table I shows the system and control

TABLE I

PARAMETER VALUES USED IN THERMAL STORAGE EXAMPLE.

System par.	Value	Ctrl par.	Value
$UA_{air-goods}$	300 ( $\frac{W}{K}$ )	$\Delta$	4 (hours)
$m_{air}$	50 (kg)	$k_1$	$\frac{1}{4}$ (-)
$C_{p,air}$	1 ( $\frac{kJ}{kgK}$ )	$k_2$	$\frac{1}{12}$ (-)
$m_{goods}$	500 (kg)	$\omega_F$	$8.7e^{-4}$ ( $\frac{rad}{s}$ )
$C_{p,goods}$	4 ( $\frac{kJ}{kgK}$ )	$\bar{\dot{Q}}_e$	$0.99\bar{\dot{Q}}_e$ (W)
$\bar{\dot{Q}}_e$	2850 (W)	$t_{end}$	9 (hours)
$\underline{\dot{Q}}_e$	0 (W)	$\bar{y}_m$	-3 ( $^\circ C$ )
		$\underline{y}_m$	-2 ( $^\circ C$ )

parameters used in the simulation. The filter  $F$  is implemented as a zero phase Butterworth low pass filter with the Matlab commands `butter` and `filtfilt` and a cutoff frequency  $\omega_F = 8.7e^{-4} \text{ rads}^{-1}$ . This gives an estimate of the required cooling  $\hat{\dot{Q}}_e$  and the precool period is increased when  $\hat{\dot{Q}}_e > 0.99\bar{\dot{Q}}_e$  and decreased otherwise.

Fig. 3 shows the simulation results with a max load of 3000 W. Without precooling the temperature increases to

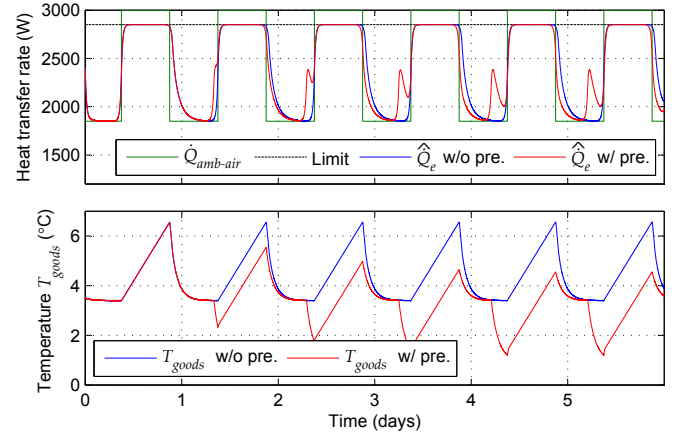

Fig. 3. Heat transfer rates and goods temperature with and without precool algorithm applied. Limit is the upper bound on the controllable input.

$6.6^\circ C$  because of the saturation kicking in at 9 in the morning every day. With precooling the maximum temperature is lowered to  $4.5^\circ C$  after four days, which is the time it takes to reach the maximum allowed precool period with the chosen learning gain  $k_1$ .

Fig. 4 shows the simulation results with a max load of 2800 W. The algorithm shifts between  $\Delta = \{0, 60, 120, 100, 80, 60, 120, 100, 80, 60, \dots\}$  minutes of precool time in this second simulation with smaller saturation. The precool time that eliminates saturation in the simulation is approximately 70 minutes.

### B. Convergence of $\Delta$ in the Trial Domain

Fig. 4 showed that the precool algorithm will cycle between levels of precool time. These levels are determined by  $k_1$  and  $k_2$ . If we decrease the learning and de-learning rates then the jump between levels will be smaller, but we will also converge slower. Let the repeatability between trials be

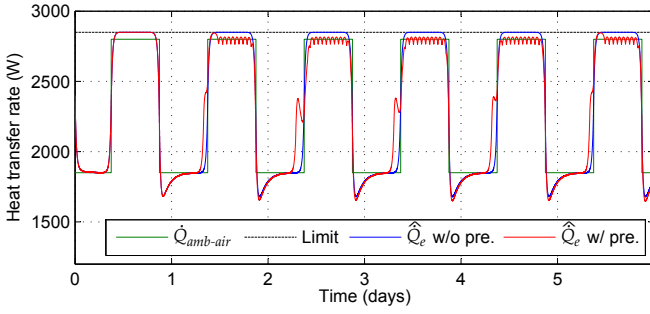

Fig. 4. Heat transfer rates with precool algorithm applied. Cool limit is the upper bound on the controllable input.

perfect and  $\Delta^*$  be the smallest possible precool time that avoids saturation, i.e.  $\Delta^* = \inf \{ \Delta : \|\hat{\mathbf{u}}\|_\infty < \bar{\mathbf{u}} \}$ , then the precool time  $\Delta_j$  at trial  $j$  will converge to the interval

$$\Delta^* - k_2 \bar{\Delta} < \Delta_j \leq \Delta^* + k_1 \bar{\Delta}, \quad (12)$$

when  $\Delta^* - k_2 \bar{\Delta} \geq 0$  and  $\Delta^* + k_1 \bar{\Delta} \leq \bar{\Delta}$ . If  $\Delta^* \leq 0$  then  $\Delta_j \rightarrow 0$  (no precooling) and if  $\Delta^* > \bar{\Delta}$  then  $\Delta_j \rightarrow \bar{\Delta}$  (max precooling). Furthermore, increasing  $k_1$  and decreasing  $k_2$  improves robustness towards hot days. On the other hand, decreasing  $k_1$  and increasing  $k_2$  optimizes the cost of running the system (assuming that no precool is cheapest).

### III. SUPERMARKET REFRIGERATION SYSTEM MODEL AND CONTROL

A supermarket refrigeration system model with control is presented in this section and illustrated in Fig. 5. The purpose

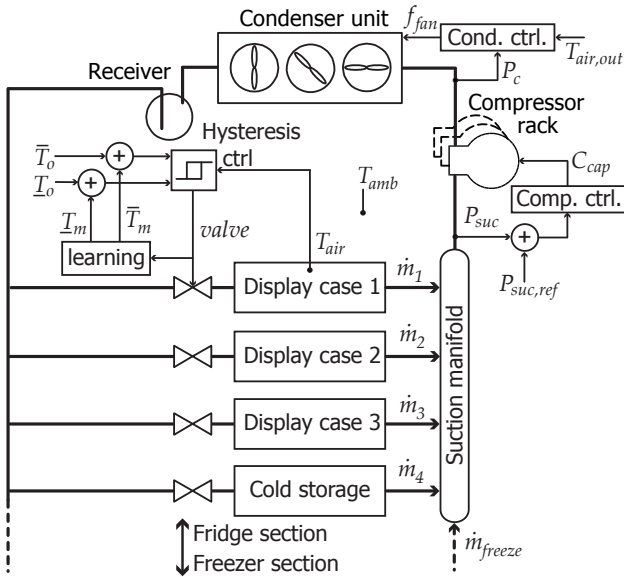

Fig. 5. Supermarket refrigeration system with multiple fridge display cases, a cold storage room, and additional mass flow from freezers  $\dot{m}_{freeze}$ . The compressor rack controls the suction pressure  $P_{suc}$ , the condenser fan controls the condenser pressure  $P_c$ , and finally the temperature of the display cases are controlled with hysteresis control and learning based adaption of the thresholds.

of this model is to provide a realistic simulation to be able to evaluate the performance of the precool algorithm and

compare it with other control strategies under the same conditions, which would not be possible on a real system. The first version of the model was derived in [15] and has been slightly modified in [16], [17], [18]. The model presented in this paper is again a slightly modified version that also takes into account the effect of changes in outside air temperature and corresponding condenser pressure, which can saturate the system on hot days due to higher required compressor work. The model is implemented in Matlab Simulink<sup>®</sup> and available for download at [www.es.aau.dk/projects/refrigeration/simulation-tools](http://www.es.aau.dk/projects/refrigeration/simulation-tools).

#### A. Simplified Supermarket Refrigeration System model with Display Cases

The display cases are assumed to be of the open shelf type with night covers as shown in Fig. 6. A lumped temperature

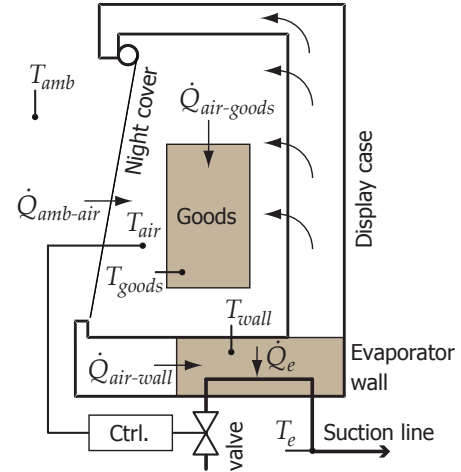

Fig. 6. Model of an open shelf type display case with night cover.

model is used and the constant circulation of air provides the heat transfer rates between the air and the evaporator wall  $\dot{Q}_{air-wall}$  and the air and the goods  $\dot{Q}_{air-goods}$ . Furthermore, heat is transferred between the evaporator wall and the refrigerant  $\dot{Q}_e$  and between the ambient air and the air inside the display case  $\dot{Q}_{amb-air}$ . Heat transfer from infiltration of air is assumed to be included in  $\dot{Q}_{amb-air}$  by choosing a higher overall heat transfer coefficient.

The differential equations for the temperatures are

$$\frac{dT_{goods}}{dt} = \frac{\dot{Q}_{air-goods}}{m_{goods}C_{p,goods}}, \quad (13)$$

$$\frac{dT_{wall}}{dt} = \frac{\dot{Q}_{air-wall} - \dot{Q}_e}{m_{wall}C_{p,wall}}, \quad (14)$$

$$\frac{dT_{air}}{dt} = \frac{\dot{Q}_{amb-air} - \dot{Q}_{air-goods} - \dot{Q}_{air-wall}}{m_{air}C_{p,air}}, \quad (15)$$

where  $m$  and  $C_p$  denotes mass and specific heat capacity,

respectively. The heat transfer rates are

$$\dot{Q}_{air-goods} = UA_{air-goods}(T_{air} - T_{goods}), \quad (16)$$

$$\dot{Q}_{air-wall} = UA_{air-wall}(T_{air} - T_{wall}), \quad (17)$$

$$\dot{Q}_e = UA_{wall-r}(T_{wall} - T_e), \quad (18)$$

$$\dot{Q}_{amb-air} = UA_{amb-air}(T_{amb} - T_{air}). \quad (19)$$

The heat transfer coefficient between the wall and the refrigerant  $UA_{wall-r}$  is a function of the amount of liquid refrigerant in the evaporator  $m_r$  given as

$$UA_{wall-r} = \overline{UA}_{wall-r} \frac{m_r}{\overline{m}_r}. \quad (20)$$

where  $\overline{UA}_{wall-r}$  is the maximum value of the heat transfer coefficient when the evaporator is fully filled (it is assumed that the superheat is controlled separately and maintained at an average value of  $T_{sh} = 10K$ ) and  $\overline{m}_r$  is the maximum mass of the liquid refrigerant. The rate of change of the mass of the refrigerant  $m_r$  is

$$\frac{dm_r}{dt} = \begin{cases} \frac{\overline{m}_r - m_r}{\tau_{fill}} & \text{if } valve = 1, \\ -\frac{\dot{Q}_e}{\Delta h_{lg}} & \text{if } valve = 0 \text{ and } m_r > 0, \\ 0 & \text{otherwise.} \end{cases} \quad (21)$$

where  $\Delta h_{lg}$  is the specific latent heat of the remaining refrigerant,  $\tau_{fill}$  is the time it takes to fill the evaporator from empty, and  $valve$  is the control signal to the valve (either on or off).

The flow of refrigerant out of the evaporator of display case  $i$  into the suction manifold is approximated by

$$\dot{m}_i = \frac{\dot{Q}_e}{\Delta h_{lg}}. \quad (22)$$

Since the suction pressure  $P_{suc}$  should be a state in the model to enable suction pressure control, we define the time derivative of the suction pressure as

$$\frac{dP_{suc}}{dt} = \frac{\sum_{i=1}^n \dot{m}_i + \dot{m}_{freeze} - \dot{V}_{comp} \rho_{suc}}{V_{suc} \frac{d\rho_{suc}}{dP_{suc}}}, \quad (23)$$

where  $\dot{m}_{freeze}$  is additional unmodeled mass flow from freezers,  $\dot{V}_{comp}$  is the volume flow out of the suction manifold due to the compressor work,  $V_{suc}$  is the volume of the manifold, and  $\rho_{suc}$  is the density in the manifold.

The compressor power  $\dot{W}_{comp}$  is approximated by

$$\dot{W}_{comp} = \frac{C_{cap}}{100} \dot{W}_{comp,max} = \frac{\dot{V}_{comp} \rho_{suc} (h_{is} - h_{oe})}{\eta} \quad (24)$$

where  $C_{cap}$  is the requested capacity in %,  $\dot{W}_{comp,max}$  is the power consumed when the compressor runs at maximum capacity,  $h_{is}$  is the specific enthalpy out of the compressor with isentropic efficiency,  $h_{oe}$  is the specific enthalpy out of the evaporator, and  $\eta$  is the efficiency from an isentropic process to the electrical power consumed by the compressor.

In order to solve the above equations a set of refrigerant specific relations are needed. They can be computed using e.g. the software RefEqns [19]. However, (25)-(29) are polynomial and regression fits to the tables provided in RefEqns

for the refrigerant R404A (all-round refrigerant good for both fridge and freezer) and the toolbox is therefore not needed.

$$\rho_{suc} = 4.669P_{suc} + 0.3672, \quad (25)$$

$$\frac{d\rho_{suc}}{dP_{suc}} = 4.669, \quad (26)$$

$$h_{is} = (3.6436 - 0.00968P_{suc} + 0.0343P_c - 0.0000495P_{suc}P_c + 0.000373P_{suc}^2 - 0.000629P_c^2)10^5, \quad (27)$$

$$h_{oe} = (0.000332P_{suc}^3 - 0.00853P_{suc}^2 + 0.0953P_{suc} + 3.3467)10^5 + \Delta h_{T_{sh}}, \quad (28)$$

$$\Delta h_{T_{sh}} = 9 (T_{sh} = 10K \text{ assumption}),$$

$$P_c = 0.00307T_c^2 + 0.1839T_c + 6.0826, \quad (29)$$

$$T_c = T_{a,out} + 5.$$

The condenser unit and the condenser control dynamics are assumed stable and fast compared to the rest. They are therefore approximated by the static relation given in (29), where the condensation pressure  $P_c$  is held at a reference corresponding to a temperature  $T_c$  which is  $5^\circ C$  above the outside air temperature  $T_{a,out}$ .

### B. On/Off Hysteresis Based Temperature Control of Refrigerated Display Cases

The temperature in each display case is controlled with an on/off valve and the relay feedback control is given as

$$valve(k) = \begin{cases} 1 & \text{if } T_{air}(k) > \overline{T}_{air}, \\ 0 & \text{if } T_{air}(k) < \underline{T}_{air}, \\ valve(k-1) & \text{otherwise,} \end{cases} \quad (30)$$

where  $\overline{T}_{air}$  and  $\underline{T}_{air}$  are the upper and lower thresholds for the temperature of the air in the display case.

### C. Compressor Rack Control

The suction pressure typically track a reference pressure  $P_{suc,ref}$  with a PI controller on the compressor rack. The control equations with anti-windup and dead-band  $DB$  are provided in (31)-(36) (see also [16]).

$$e(k) = P_{suc,ref} - P_{suc}, \quad (31)$$

$$e_{DB}(k) = \begin{cases} e(k) & \text{if } |e(k)| > DB, \\ 0 & \text{otherwise,} \end{cases} \quad (32)$$

$$I(k) = I(k-1) + \frac{K_{p,comp} t_s}{\tau_{i,comp}} e_{DB}(k) + w(k), \quad (33)$$

$$C_{cap}(k) = K_{p,comp} e_{DB}(k) + I(k), \quad (34)$$

$$C_{cap,s}(k) = \begin{cases} \overline{C}_{cap} & \text{if } C_{cap}(k) > \overline{C}_{cap}, \\ \underline{C}_{cap} & \text{if } C_{cap}(k) < \underline{C}_{cap}, \\ C_{cap}(k) & \text{otherwise,} \end{cases} \quad (35)$$

$$w(k+1) = \frac{t_s}{\tau_{i,comp}} (C_{cap,s}(k) - C_{cap}(k)). \quad (36)$$

### D. Weather Data

A yearlong weather data file for Phoenix, Arizona with 1 minute samples is used to simulate real outdoor temperatures. Fig. 7 shows the seasonal change in temperature.

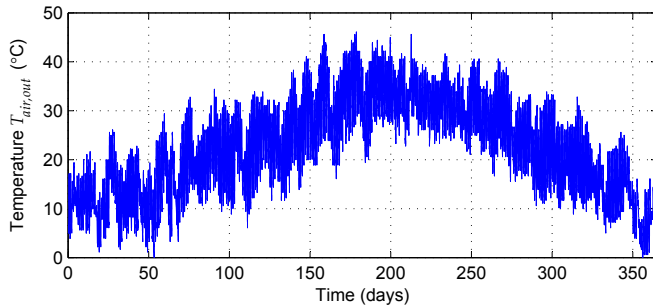

Fig. 7. Outdoor air temperature  $T_{air,out}$  from 1st of January to 31st of December in Phoenix Arizona based on typical meteorological year (TMY) 2 weather data.

### E. Foodstuff Storage Potential Considerations

Refrigerated foodstuff has different thermal storage potential mainly determined by the overall heat transfer coefficient, total surface area, mass, and specific heat capacity of the product. Another important quantity is the Biot number, which indicates if a lumped or nonlumped temperature analysis is appropriate. The Biot number  $B$  is the ratio of internal temperature difference required to move energy within a product to temperature difference required at the surface to add or remove the same energy given as [20]

$$B = \frac{UV}{kA}, \quad (37)$$

where  $U$  is the surface heat transfer coefficient,  $V$  is the volume,  $A$  is the surface area exposed to convective heat transfer, and  $k$  is the products thermal conductivity. A small number ( $< 0.1$ ) means that the temperature will not vary significantly in space inside the body [20]. However, a nonlumped analysis would be more appropriate if it is large.

Biot numbers for different foodstuffs are provided based on experiments in [8]. Even though they in general are above 0.1, a lumped analysis is often performed, because it does not require solving complex multidimensional partial differential equations. The lumped approach is also taken here. However, it is possible to activate the entire mass of the foodstuff during precooling and the system also gradually becomes more saturated, due to increasing outside temperature, which means that the average air temperature in the display case only changes slowly over several hours.

Due to the night cover in open shelf type display cases there will be a large increase in the overall heat transfer coefficient between the ambient air and the air inside the display case during the opening hours of the supermarket. This is also when there is customer activity and it gives a high increase in heat load and will be modeled in the simulations conducted in Section V. Furthermore, in order to evaluate the thermal storage potential of different foodstuffs, different combinations of mass times specific heat  $mC_p$  and overall heat transfer coefficient times surface area  $UA$  are used in the simulated display cases. These parameters determine the main time constant for the foodstuff temperature and a step in air temperature is made from  $3.5^\circ\text{C}$  to  $1^\circ\text{C}$  using (13) to determine how long it takes to precool the foodstuff from

the initial value to 90% of the step size. The time is 166 min for Display Case 1, 250 min for Display Case 2, 500 min for Display Case 3, and 300 min for the cold storage room.

## IV. PRECOOL ALGORITHM TUNING GUIDELINE FOR REFRIGERATION SYSTEMS

**Learning gains  $k_1$  and  $k_2$ :** These are tuning parameters with a value between 0 and 1 and they are also discussed in Subsection II-B. The choice should be relative to how changeable the weather is expected to be. The safest option is  $k_1 = 1$  and  $k_2$  small. However, this will also result in more precooling than necessary. Simulations have shown that  $k_1 = \frac{1}{4}$  and  $k_2 = \frac{1}{12}$  are suitable with the representative weather data presented in Subsection III-D.

**Filter parameters  $\omega_F$  and  $\hat{valve}$ :** The low pass filter that converts the on/off signal to the valve to a duty cycle (utilized capacity) will depend on the switching times. The switching period usually lie somewhere between 5-15 minutes for display cases and the cutoff frequency  $\omega_F = 8.7e^{-4} \frac{rad}{s}$  is chosen, which correspond to a frequency period of about two hours. The threshold duty cycle  $\hat{valve}$  is set to 0.99, which means that if the utilized capacity of the display case reaches 99% of maximum we will start to precool.

**Max precool time  $\bar{\Delta}$ :** This value is individual for each display case and should correspond to the time it takes to cool the foodstuff from an initial temperature using normal temperature thresholds to the steady state temperature using precool thresholds, see Subsection III-E. It can either be chosen based on experience or experiments. In cases where the foodstuff temperature is not measured, a step down in the air temperature thresholds can reveal the time constant of the foodstuff. This can be achieved by monitoring how long it takes the valve duty cycle to settle again after the step, which happens when the foodstuff temperature has settled (longer precool will not store any additional thermal energy). The experiment could potentially be performed automatically during the night or once just after the controller is installed.

**Precool end time  $t_{end}$ :** This could be set manually based on supermarket opening hours, energy tariff, experience, etc. It can also be set and updated automatically based on the estimated duty cycle output from the filter  $F$ , which indicates when the system went into saturation on the previous day. The precooling should take place before this saturation. In the simulation results presented in Section V,  $t_{end}$  is determined as the time when the longest saturation period started the day before. The low thresholds in the precool period are also extended beyond  $t_{end}$  to include the saturation period. This ensures that the stored thermal energy is not lost immediately but kept for as long as possible.

## V. SIMULATION RESULTS

Table II shows the parameter values used in the simulation. The compressor size is dimensioned so that the foodstuff temperature stays below  $5^\circ\text{C}$  the whole year with the representative weather data, if the thresholds are constantly kept on low settings. No precool would result in some days where the foodstuff goes above  $5^\circ\text{C}$ , which is used as a benchmark

and precooling all the time is expensive energy wise. The precool algorithm is therefore compared with these two extremes in terms of energy consumption and temperature.

TABLE II

PARAMETER VALUES USED IN SUPERMARKET SYSTEM SIMULATION. SUBSCRIPT 1 – 3 DENOTES DISPLAY CASES AND  $cs$  IS COLD STORAGE.

System par.	Value	Ctrl par.	Value
$UA_{amb-air,l}$	75 ( $\frac{W}{K}$ )	$\bar{\Delta}_1$	166+60 (min)
$UA_{amb-air,h}$	150 ( $\frac{W}{K}$ )	$\bar{\Delta}_2$	250+60 (min)
$UA_{amb-air,cs}$	110 ( $\frac{W}{K}$ )	$\bar{\Delta}_3$	500+60 (min)
$UA_{air-goods,1}$	450 ( $\frac{W}{K}$ )	$\bar{\Delta}_{cs}$	300+60 (min)
$UA_{air-goods,2}$	300 ( $\frac{W}{K}$ )	$\omega_F$	$8.7e^{-4}$ ( $\frac{rad}{s}$ )
$UA_{air-goods,3}$	150 ( $\frac{W}{K}$ )	$valve$	0.99 (–)
$UA_{air-goods,cs}$	600 ( $\frac{W}{K}$ )	$k_1$	$\frac{1}{4}$ (–)
$UA_{air-wall}$	500 ( $\frac{W}{K}$ )	$k_2$	$\frac{1}{12}$ (–)
$\bar{UA}_{wall-r}$	900 ( $\frac{W}{K}$ )	$\bar{T}_m$	-3 ( $^{\circ}C$ )
$C_{p,goods}$	3917 ( $\frac{J}{kgK}$ )	$T_m$	-2 ( $^{\circ}C$ )
$C_{p,air}$	1000 ( $\frac{J}{kgK}$ )	$\bar{T}_o$	5 ( $^{\circ}C$ )
$C_{p,wall}$	385 ( $\frac{J}{kgK}$ )	$T_o$	2 ( $^{\circ}C$ )
$m_{wall}$	180 (kg)	$P_{suc,ref,l}$	4.4 (bar)
$m_{air,1-3}$	50 (kg)	$P_{suc,ref,h}$	4.1 (bar)
$m_{air,cs}$	125 (kg)	$DB$	0.1 (bar)
$\bar{m}_r$	0.6 (kg)	$K_p$	-10 (–)
$m_{goods,1-3}$	500 (kg)	$T_i$	220 (s)
$m_{goods,cs}$	1200 (kg)	$t_{s,comp}$	60 (s)
$\tau_{fill}$	40 (s)	$t_{s,ilc}$	5 (s)
$T_{amb}$	22 ( $^{\circ}C$ )		
$\eta$	0.5 (–)		
$\bar{W}_{comp}$	7985 (W)		
$\dot{m}_{freeze}$	0.05 ( $\frac{kg}{s}$ )		

The heat transfer coefficient  $UA_{amb-air,l}$  is used for the display cases when the night cover is on when the supermarket is closed and  $UA_{amb-air,h}$  is used when the night cover is off in the opening hours from 9 am to 9 pm. A variation with a factor of two is used and this also includes the extra load due to exchange of foodstuff during the day. Zero mean Gaussian noise is also added to the simulation. The standard deviation for the noise added to  $UA_{amb-air,l}$ ,  $UA_{amb-air,h}$ , and  $UA_{amb-air,cs}$  during the opening hours is 5 and 1 during closed hours. Noise is also added to the mass flow from freezers  $\dot{m}_{freeze}$  with a standard deviation of 0.0032. It is assumed that the supermarket is open the same hours all week and all year and that the customer load is even during the day. Individual learning controllers could be activated for each day or maybe for weekdays and weekends, if some days look different. Finally, note that one hour is added to  $\bar{\Delta}$  to account for uncertainties and the sample time for the precool algorithm  $t_{s,ilc}$  is set to 5 seconds.

Fig. 8 shows the simulation result with and without precool algorithm activated for four days during the summer period out of the 365 day long simulation. The compressor capacity  $C_{cap}$  saturates during the supermarket opening hours. This results in an increase in the suction pressure, which gets worse as the outside temperature increases. The valve duty cycle also saturates and the air and foodstuff temperature goes up. The foodstuff temperature goes beyond  $5^{\circ}C$  during day 177 and 178, if precooling is not performed.

Fig. 9 shows the precool time for each day during the

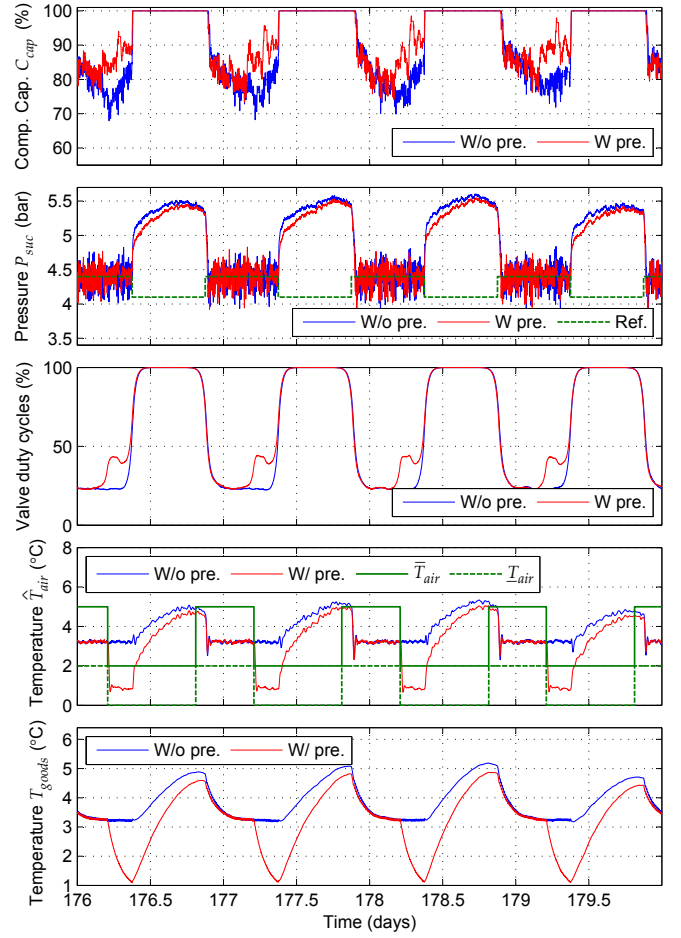

Fig. 8. Compressor capacity, suction pressure, valve duty cycle (approximated), air temperature (filtered), and foodstuff temperature in Display Case 2 with and without precool algorithm applied for selected days.

simulation with the precool algorithm. Precool is mostly activated during the hot summer period as expected and goes to  $\bar{\Delta}$  for each of the storages. By defining the accumulated errors in temperature constraint satisfaction  $\gamma_{con}$  as

$$\gamma_{con} = \sum_{i=1}^n \epsilon_{T_i} t_s \quad (38)$$

$$\epsilon_{T_i} = \begin{cases} T_i - \bar{T}_i & \text{if } T_i > \bar{T}_i \\ \underline{T}_i - T_i & \text{if } T_i < \underline{T}_i \\ 0 & \text{otherwise,} \end{cases}$$

we get a measure of how much the constraints 0 and  $5^{\circ}C$  for the foodstuff are violated during the simulations. Furthermore, the energy charge is calculated based on a 2010 time-of-use tariff for Phoenix, Arizona [21]. Table III sums up the results. The temperature threshold is violated in Display Case 1 in five days and in Display Case 2 in four days when precooling is not used. The cost increase from no precool to constant precool is 4.24% and 1.21% from no precool to variable precool, which shows the advantage of the precool algorithm. Even though the precool algorithm costs 1.21% more to run, it also approximately maintains a  $0.3^{\circ}C$  lower average foodstuff temperature, which will result



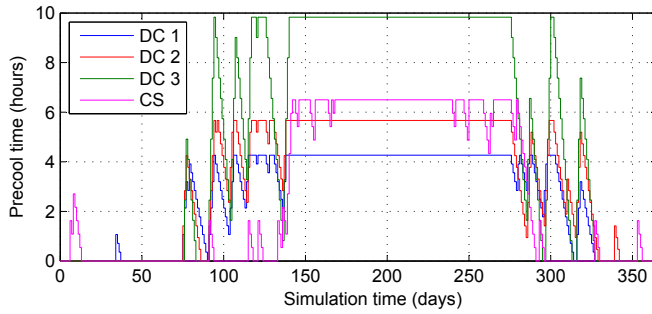

Fig. 9. Preecool time in hours for each day in the simulation with precool.

TABLE III

SUMMARY OF CASE STUDY RESULTS FOR SIMULATION FROM 1ST OF JANUARY TO THE 31ST OF DECEMBER.

Quantity	No precool	Variable precool	Constant precool
$\gamma_{con}(T_{goods,1})$	7481	0	0
$\gamma_{con}(T_{goods,2})$	3679	0	0
$\gamma_{con}(T_{goods,3})$	0	0	0
$\gamma_{con}(T_{goods,cs})$	0	0	0
Avg. $T_{goods,1}$ ( $^{\circ}C$ )	3.44	3.12	1.33
Avg. $T_{goods,2}$ ( $^{\circ}C$ )	3.35	2.97	1.31
Avg. $T_{goods,3}$ ( $^{\circ}C$ )	3.24	2.68	1.31
Avg. $T_{goods,3}$ ( $^{\circ}C$ )	3.26	2.93	0.88
$T_{goods,1}$ above lim. (days)	5	0	0
$T_{goods,2}$ above lim. (days)	4	0	0
$T_{goods,3}$ above lim. (days)	0	0	0
$T_{goods,cs}$ above lim. (days)	0	0	0
Total energy (kWh)	54742	55401	57235
Energy charge (U.S. \$)	3089	3126	3220

in a small decrease in bacteria growth.

## VI. CONCLUSION

Foodstuff has thermal storage capabilities. A learning based algorithm has been proposed that automatically starts to precool the foodstuff at the appropriate time if the refrigeration system becomes saturated during hot days or because of component performance degradation and can thus help prevent deterioration of foodstuff. A model of a supermarket refrigeration system with multiple display cases was derived and simulations for an entire year showed that precooling could prevent violation of an upper temperature threshold during the hottest days. The cost of running the algorithm was also less than if precool was applied all the time.

The learning based algorithm does not require any additional hardware nor a system model. Furthermore, the experience based approach ensures that the precool control adapts to load changes, e.g. due to the seasonal temperature differences and to system changes, e.g. component wear. This means that it can easily be plugged into existing systems and thus provides an interesting alternative to model based approaches such as MPC and precooling based on fixed schedules. The method could potentially be used in other applications as well such as warehouses, refrigerated transports, freezers, ice production, building air conditioning, etc. The only requirement is that there is enough repeatability in the load pattern to allow the learning to converge. The

precool might not last all day, but it is considerably better than doing nothing.

## REFERENCES

- [1] G. P. Henze and M. Krati, "Ice Storage System Controls for the Reduction of Operating Cost and Energy Use," *Journal of Solar Energy Engineering*, vol. 120, no. 4, pp. 275–281, November 1998.
- [2] J. E. Braun, "Load Control Using Building Thermal Mass," *Journal of Solar Energy Engineering*, vol. 125, no. 3, pp. 292–301, August 2003.
- [3] G. Zhou, M. Krati, and G. P. Henze, "Parametric Analysis of Active and Passive Building Thermal Storage Utilization," *Journal of Solar Energy Engineering*, vol. 127, no. 1, pp. 37–46, February 2005.
- [4] Y. Ma, A. Kelman, A. Daly, and F. Borrelli, "Predictive Control for Energy Efficient Buildings with Thermal Storage: Modeling, Simulation, and Experiments," *IEEE Control Systems Magazine*, vol. 32, no. 1, pp. 44–64, February 2012.
- [5] J. E. Altwies and D. T. Reindl, "Passive thermal energy storage in refrigerated warehouses," *International Journal of refrigeration*, vol. 25, no. 1, pp. 149–157, January 2002.
- [6] J. Cai, "Control of Refrigeration Systems for Trade-off between Energy Consumption and Food Quality Loss," Ph.D. dissertation, Section of Automation and Control, Department of Electronic Systems, Aalborg University, 2007.
- [7] T. G. Hovgaard, L. F. S. Larsen, and J. B. Jørgensen, "Flexible and Cost Efficient Power Consumption using Economic MPC A Supermarket Refrigeration Benchmark," in *IEEE Conference on Decision and Control and European Control Conference*, Orlando, Florida, December 2011, pp. 848–854.
- [8] T. G. Hovgaard, L. F. S. Larsen, and M. J. Skovrup, "Analyzing Control Challenges for Thermal Energy Storage in Foodstuffs," in *IEEE Multi-Conference on Systems and Control*, Dubrovnik, Croatia, October 2012, pp. 956–961.
- [9] R. W. Longman, "Iterative learning control and repetitive control for engineering practice," *International Journal of Control*, vol. 73, no. 10, pp. 930–954, 2000.
- [10] D. A. Bristow, M. Tharayil, and A. G. Alleyne, "A survey of iterative learning control," *IEEE Control Systems Magazine*, vol. 26, no. 3, pp. 96–114, June 2006.
- [11] Y. Wang, F. Gao, and F. J. Doyle, "Survey on iterative learning control, repetitive control, and run-to-run control," *Journal of Process Control*, vol. 19, no. 10, pp. 1589–1600, December 2009.
- [12] B. E. Helfrich, C. Lee, D. A. Bristow, X. H. Xiao, J. Dong, A. G. Alleyne, S. M. Salapaka, and P. M. Ferreira, "Combined  $H_{\infty}$ -Feedback and Iterative Learning Control Design with Application to Nanopositioning Systems," in *American Control Conference*, Seattle, Washington, USA, June 2008, pp. 3983–3990.
- [13] K. Vinther, V. Chandan, and A. G. Alleyne, "Learning/Repetitive Control for Building Systems with Nearly Periodic Disturbances," Submitted for publication.
- [14] S. Mishra, U. Topcu, and M. Tomizuka, "Optimization-Based Constrained Iterative Learning Control," *IEEE Transactions on Control Systems Technology*, vol. 19, no. 6, pp. 1613–1621, 2011.
- [15] L. F. S. Larsen, "Model Based Control of Refrigeration Systems," Ph.D. dissertation, Section of Automation and Control, Department of Electronic Systems, Aalborg University, 2005.
- [16] L. F. S. Larsen, R. Izadi-Zamanabadi, and R. Wisniewski, "Supermarket Refrigeration System - Benchmark for Hybrid System Control," in *European Control Conference*, Kos, Greece, July 2007.
- [17] C. Sonntag, A. Devanathan, and S. Engell, "Hybrid NMPC of a Supermarket Refrigeration System using Sequential Optimization," in *17th IFAC World Congress*, Seoul, Korea, July 2008, pp. 13 901–13 906.
- [18] Z. Yang, K. B. Rasmussen, A. T. Kieu, and R. Izadi-Zamanabadi, "Fault Detection and Isolation for a Supermarket Refrigeration System - Part One: Kalman-Filter-Based," in *18th IFAC World Congress*, Milano, Italy, September 1985, pp. 13 233–13 238.
- [19] M. Skovrup, "Thermodynamic and thermophysical properties of refrigerants - software package in borland delphi," Technical University of Denmark, Tech. Rep., 2000.
- [20] *ASHRAE Handbook - Fundamentals (SI Edition)*. American Society of Heating, Refrigeration and Air-conditioning Engineers, Inc., 2005.
- [21] APS, "Rate Schedule E-32TOU S - Small General Service (21 kW - 100 kW) - Time of Use," Arizona Public Service Company, Tech. Rep., 2010. [Online]. Available: [http://www.aps.com/\\_files/rates/e-32TOUS.pdf](http://www.aps.com/_files/rates/e-32TOUS.pdf)