



Aalborg Universitet

AALBORG UNIVERSITY
DENMARK

Power flow analysis for droop controlled LV hybrid AC-DC microgrids with virtual impedance

Li, Chendan; Chaudhary, Sanjay K.; Quintero, Juan Carlos Vasquez; Guerrero, Josep M.

Published in:

Proceedings of the IEEE Power & Energy Society General Meeting, PES 2014

DOI (link to publication from Publisher):

[10.1109/PESGM.2014.6939887](https://doi.org/10.1109/PESGM.2014.6939887)

Publication date:

2014

Document Version

Early version, also known as pre-print

[Link to publication from Aalborg University](#)

Citation for published version (APA):

Li, C., Chaudhary, S., Vasquez, J. C., & Guerrero, J. M. (2014). Power flow analysis for droop controlled LV hybrid AC-DC microgrids with virtual impedance. In Proceedings of the IEEE Power & Energy Society General Meeting, PES 2014 (pp. 1-4). IEEE Press. DOI: 10.1109/PESGM.2014.6939887

General rights

Copyright and moral rights for the publications made accessible in the public portal are retained by the authors and/or other copyright owners and it is a condition of accessing publications that users recognise and abide by the legal requirements associated with these rights.

- ? Users may download and print one copy of any publication from the public portal for the purpose of private study or research.
- ? You may not further distribute the material or use it for any profit-making activity or commercial gain
- ? You may freely distribute the URL identifying the publication in the public portal ?

Take down policy

If you believe that this document breaches copyright please contact us at vbn@aub.aau.dk providing details, and we will remove access to the work immediately and investigate your claim.

Power flow analysis for droop controlled LV hybrid AC-DC microgrids with virtual impedance

Chendan Li, Sanjay K. Chaudhary, Juan C. Vasquez, and Josep M. Guerrero

Department of Energy Technology, Aalborg University

Aalborg, Denmark

{che, skc, juq, joz}@et.aau.dk

Abstract— The AC-DC hybrid microgrid is an effective form of utilizing different energy resources and the analysis of this system requires a proper power flow algorithm. This paper proposes a suitable power flow algorithm for LV hybrid AC-DC microgrid based on droop control and virtual impedance. Droop and virtual impedance concepts for AC network, DC network and interlinking converter are reviewed so as to model it in the power flow analysis. The validation of the algorithm is verified by comparing it with steady state results from detailed time domain simulation. The effectiveness of the proposed algorithm makes it a potential method for planning, dispatching and operation of droop controlled LV hybrid AC-DC.

Index Terms—hybrid AC-DC microgrid, droop control, virtual impedance, power flow.

I. INTRODUCTION

Recent technology development and practice in power system has witnessed increasing interests on the concept of “direct DC”, from the adoption of High-voltage direct-current (HVDC) transmission systems when connecting offshore wind farms or large distance interconnected grids, to energy efficient applications in distribution system that utilize DC power directly from the source residentially or commercially for the purpose of avoiding DC-AC-DC power conversions. Among these applications, DC microgrid, which comprises distributed generation, energy storage systems and local loads as a local grid, is gaining more interests due to its potential to integrate increasing DC renewable source and load, such as, electrical vehicles, photovoltaic systems, fuel cells, or LEDs, with high efficiency. The application of DC microgrids have increasingly been found its way in data centers, telecom system, and some buildings and offices.

DC microgrids are, however, not likely to fully replace an existing AC microgrid due to the long historical development of the AC power system. The architecture of the coexistence of AC and DC subgrids intertied by an electronically controlled power converter is here to stay [1]-[5]. The structure of an example of hybrid AC-DC microgrid is shown in Fig. 1. This hybrid network consists of two DC subgrids and one AC subgrid, and the main grid is connected with it by an intelligent bypass switch.

One of the main purposes of the management for the microgrid is the control of the power flow. To achieve this goal, among many control strategies, hierarchical control

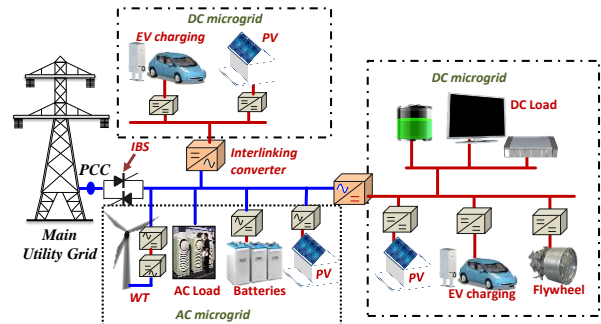

Figure 1. Structure of an example of hybrid AC-DC microgrid

methodology is proposed in [1] as a generalized and even standard way for AC microgrid and DC microgrid. The steady state power distribution is the direct control outcome of the primary control of the hierarchical control.

To make the planning, dispatch and operation more economical and reliable, a steady state power flow analysis for a microgrid is always desired. For this purpose, a lot of work has been done [6]–[8], but they all aimed at the AC microgrid only. Moreover, to a certain extent, none of them is suitable for Low voltage AC microgrid, either because they use conventional concepts of PQ, PV and slack buses in the modelling or due to that they overlooked the effect of the virtual impedance[7]. Power flow analysis for AC-DC power system is not a new topic, yet many of them are addressed for HVDC system thus not suitable for a hybrid microgrid with its unique power flow control based on droop and virtual impedance[9]-[11].

This paper, a power flow for hybrid AC-DC microgrid is proposed considering the droop control with virtual impedance and power flow among microgrids through interlinking converter control. The paper is organized as follows. In the second section, power flow control strategy based on the droop control and virtual impedance for single microgrid and intertied microgrids are reviewed as background knowledge to justify the choice of modelling method in the next section. In the third section, mathematical model of proposed power flow analysis is presented based on the control discussed previously. The verification of the proposed algorithm by comparing the results from calculation and the steady state results from time domain simulation is

provided in the fourth section which shows the effectiveness of the algorithm. Finally, section five gives the conclusions and the future work.

II. DROOP CONTROL AND VIRTUAL IMPEDANCE SCHEME IN MICROGRIDS

A. For a single LV AC microgrid

The concept of the droop control with virtual impedance is illustrated in Fig.2. As is shown in it, when the virtual impedance Z_v equals zero, i.e., virtual impedance is not used, the output characteristic of generation is controlled by the droop equation as (1) and (2) to mimic the synchronous generator in the bulk grid.

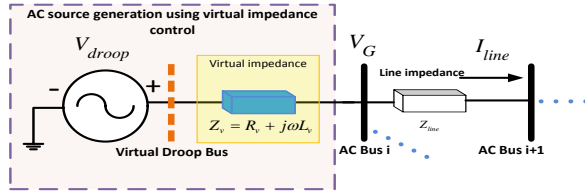

Figure 2. Concept of droop control with virtual impedance in a single AC microgrid

$$f^* = f_{0i} - K_{Pi} P_{Gi} \quad (1)$$

$$|V_{Gi}| = |V_{G0i}| - K_{Qi} Q_{Gi} \quad (2)$$

Being f_{0i} , K_{Pi} , P_{Gi} , V_{G0i} , K_{Qi} , Q_{Gi} the nominal frequency, proportional frequency droop parameter, real power generation, nominal voltage, proportional voltage amplitude droop parameter, and reactive power at generator i , respectively.

But when the virtual impedance is added in the control so as to decouple real and reactive power when the line impedance is not inductive enough, it changes the output voltage characteristics of the generation as is shown in (3).

$$\begin{aligned} V_G &= V_{droop} - I_G Z_v \\ &= V_{droop} - (Y_{Gbus} V_G) Z_v \end{aligned} \quad (3)$$

Where the V_{droop} is the voltage matrix of the virtual droop bus, I_{Gline} the injection current matrix in the generation bus, Y_{Gbus} the admittance matrix of the network directed connected to the generation buses, Z_v the virtual impedance matrix of the controller and V_G the voltage matrix of generation bus (assume all the generation buses are droop controlled).

B. For a single LV DC microgrid

The principle of the droop control for LV DC microgrid is illustrated in Fig. 3. In fact, the realization of droop control in DC microgrid is through the use of the virtual resistance R_D . DC sources in a network cannot work as stiff voltage sources for there will be circulating current. The droop concept has thus come into being by multiplication of measured voltage deviation to a value reciprocal to the virtual resistance. The concept is illustrated by (4).

$$V_{Gi(DC)} = V_{0i(DC)} - R_{Di} i_{Gi(DC)} \quad (4)$$

Where $V_{Gi(DC)}$ is the voltage reference to DC source which should be equal to the measured voltage value in a stable

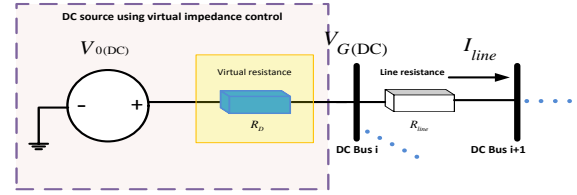

Figure 3. Concept of droop control using virtual impedance in a single DC microgrid

system in the steady state, $V_{0i(DC)}$ is the output reference at no load which is usually modified from secondary control to achieve voltage regulation, R_{Di} is the virtual impedance of the droop controller, and $i_{Gi(DC)}$ is the output current of the DC source.

C. For intertied microgrids

Droop concepts can also be applied to two different microgrids by controlling the interlinking converter as are proposed in [1]-[4]. Although the droop concept is used in the control of the interlinking converter, the interlinking converter cannot be seen as a droop controlled converter to each interconnected side as in a single microgrid. There are mainly two control objectives which are realized by using droop concepts. One is aiming at making the two intertied connected microgrids being studied share all the load equally [2], another is aiming at making the two intertied microgrids equally stressed and minimize the interlinking energy flow by controlling the power transferred according to the load condition of the two microgrids [3]. Despite different control objectives, to make the droop coefficients comparable, the variables used for sharing the real power as the signals need to be normalized to common per unit range. Moreover, despite different control strategy the ultimate given to the interlinking converter is the transferred power through it. To make the model of the interlink converter control strategy independent, the generalized form of the power flow control in the interlinking converter can be show in fig. 4. The direction of the arrow indicates the positive direction of the power. Reactive power cannot be transferred through the interlinking converter and that is why there is only Q_{c1} in the AC side. The transferred real power satisfies the following equations consider the converter power loss and the possible energy storage system in the DC link of the converter.

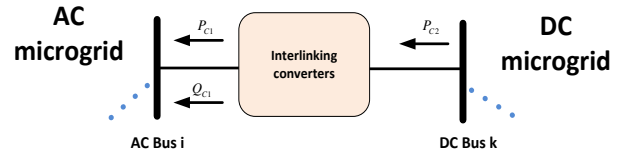

Figure 4. Concept of droop control with virtual impedance in a single AC microgrid

$$P_{c2} - P_{c1} = P_{loss} + P_{storage} \quad (5)$$

III. MATHEMATICAL MODEL OF POWER FLOW IN LV HYBRID AC-DC MICROGRID

For the AC buses, taking into account that the frequency is a global variable for all the DG buses throughout the microgrid, from (1) we can obtain:

$$f_{0i} - K_{P_i} P_{G_i} = f_{0g} - K_{P_g} P_{G_g} \quad (6)$$

where $i=1, \dots, g-1$, being g the number of the buses.

The network equations that all buses should obey are given by:

$$P_i = V_i \sum V_j (G_{ij} \cos \theta_{ij} + B_{ij} \sin \theta_{ij}) \quad (7)$$

$$Q_i = V_i \sum V_j (G_{ij} \sin \theta_{ij} - B_{ij} \cos \theta_{ij}) \quad (8)$$

Where θ_{ij} , G_{ij} and B_{ij} are the bus admittance angle, the conductance and the susceptance, respectively.

For DC buses, it is possible to assume the network is pure resistive in its steady state model. According to the Kirchhoff's current law, that current injected at the bus i equals to the current flowing to other buses, the network equation can be written as follows:

$$I_{i(\text{DC})} = \sum_{\substack{j=1 \\ j \neq i}}^n Y_{ij(\text{DC})} (V_{i(\text{DC})} - V_{j(\text{DC})}) \quad (9)$$

Where $I_{i(\text{DC})}$ is the DC injection current in bus i , $Y_{ij(\text{DC})}$ is the admittance between the bus i and bus j , and $V_{i(\text{DC})}$ is the voltage magnitude in bus i ;

$$\frac{P_{i(\text{DC})}}{V_{i(\text{DC})}} = \sum_{\substack{j=1 \\ j \neq i}}^n Y_{ij(\text{DC})} (V_{i(\text{DC})} - V_{j(\text{DC})}) \quad (10)$$

Additionally, for the Droop-buses, there is one more constraint they have to follow:

$$V_{G_i(\text{DC})} = V_{0i(\text{DC})} - R_{D_i} i_{G_i(\text{DC})} \quad (11)$$

Where $i_{G_i(\text{DC})}$ can be written as,

$$i_{G_i(\text{DC})} = \frac{P_{G_i(\text{DC})}}{V_{G_i(\text{DC})}} \quad (12)$$

Considering the virtual impedance constraint (3) for AC buses, and assuming there is no energy storage in the DC link and the power loss in the converter is not significant which is reasonable in LV small microgrid system, the overall mathematical model of power flow analysis for a hybrid microgrid is as follows:

$$f_{0i} - f_{0g} - K_{P_i} P_{G_i} + K_{P_g} P_{G_g} = 0 \quad (13)$$

$$|V_{G_{0i}}| - |V_{G_i}| - K_{Q_i} Q_{G_i} = 0 \quad (14)$$

$$P_{G_i} - P_{D_i} - P_i + P_{c1} = 0 \quad (15)$$

$$Q_{G_i} - Q_{D_i} - Q_i + Q_{c1} = 0 \quad (16)$$

$$V_G - V_{droop} + (Y_{Gbus} V_G) Z_v = 0 \quad (17)$$

$$\frac{P_{dc,i}}{V_{dc,i}} = \sum_{\substack{j=1 \\ j \neq i}}^n Y_{dc,ij} (V_{dc,i} - V_{dc,j}) \quad (18)$$

$$V_{G_i(\text{DC})} = V_{0i(\text{DC})} - R_D \frac{P_{G_i(\text{DC})}}{V_{G_i(\text{DC})}} \quad (19)$$

$$P_{G_i(\text{DC})} - P_{D_i(\text{DC})} - P_{dc,i} - P_{c2} = 0 \quad (20)$$

IV. ALGORITHM VERIFICATION ON A TEST HYBRID MICROGRID

The validity of the algorithm is verified using a 10-bus hybrid microgrid by comparing the results from calculation and the steady state results from time domain simulation with the toolbox SimPowerSystems of Matlab as is shown in Fig.5. According to [3], it defines four basic rules for the control of transferred power, the real power flow will have three different cases: scenario 1, real power flows from AC side to DC side; scenario 2, real power flows from DC side to AC side; and scenario 3, no power flows in between. Since the last case is equivalent to calculate two separated AC network and DC network, only first two cases are tested. The network data and control parameters are listed in Table I.

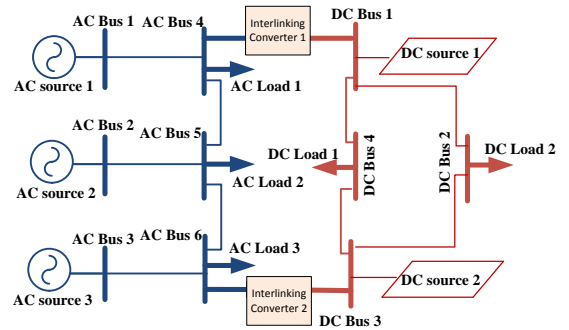

Figure 5. Single line diagram of test hybrid microgrid

TABLE I. THE NETWORK DATA AND CONTROL PARAMETERS OF TEST HYBRID MICROGRID

| paramaters | symbol | value | units |
|-------------------------|--------|--------|-------------|
| frequency droop for DG1 | KP1 | 0.001 | rad/(W · s) |
| amplitude droop for DG1 | KQ1 | 0.02 | V/Var |
| frequency droop for DG2 | KP2 | 0.0005 | rad/(W · s) |
| amplitude droop for DG2 | KQ2 | 0.01 | V/Var |
| frequency droop for DG3 | KP3 | 0.004 | rad/(W · s) |

| | | | |
|------------------------------------|-------------------|-----------------------------|----------------------|
| amplitude droop for DG3 | KQ3 | 0.002 | V/Var |
| Virtual resistor | Rv_i(i=1,2,3) | 0.1 | Ω |
| Virtual inductor | Lv_i(i=1,2,3) | 0.004 | H |
| reference voltage in DC bus 1 | Vref1 | 48 | V |
| reference voltage in DC bus 2 | Vref2 | 48 | V |
| Virtual resistance for DC source 1 | Rd1 | 0.2 | Ω |
| Virtual resistance for DC source 2 | Rd2 | 0.5 | Ω |
| bus number | Rload(Ω) | Lload(mH) | |
| DC bus 2 | 5 | 0 | |
| DC bus 4 | 3 | 0 | |
| AC bus 4 | 100 | 0 | |
| AC bus 5 | 100 | 0 | |
| AC bus 6 | 100 | 0.25136H | |
| from bus | to bus | Line resistance(Ω) | line inductance (mH) |
| DC bus 1 | DC bus 2 | 0.05 | 0 |
| DC bus 2 | DC bus 3 | 0.04 | 0 |
| DC bus 3 | DC bus 4 | 0.08 | 0 |
| DC bus 4 | DC bus 1 | 0.03 | 0 |
| AC bus 1 | AC bus 4 | 0.15 | 0.062 |
| AC bus 2 | AC bus 5 | 0.21 | 0.096 |
| AC bus 3 | AC bus 6 | 0.11 | 0.048 |
| AC bus 4 | AC bus 5 | 0.12 | 0.031 |
| AC bus 5 | AC bus 6 | 0.15 | 0.062 |

In scenario 1, real power 200W and 300W is flowing from AC network to DC network through interlinking converter 1 and 2 respectively. The comparison results of generation buses are shown in Table II.

TABLE II. COMPARISON RESULTS WHEN REAL POWER FROM AC TO DC

| Node | SimPowerSystem results | | Power Flow Results | |
|----------|------------------------|----------|--------------------|----------|
| | Mag.(p.u.) | Power(W) | Mag.(p.u.) | Power(W) |
| DC bus 1 | 0.99541 | 525.76 | 0.99993 | 520.79 |
| DC bus 3 | 0.99597 | 184.812 | 0.99994 | 182.4 |
| AC bus 1 | 0.97680 | 1289.07 | 0.97661 | 1287.94 |
| AC bus 2 | 0.97947 | 2578.13 | 0.97921 | 2575.87 |
| AC bus 3 | 0.97562 | 644.532 | 0.97547 | 643.97 |

In scenario 2, the real power 200W and 300W is flowing from DC network to AC network. The comparison results of generation buses are shown in Table III.

TABLE III. COMPARISON RESULTS WHEN REAL POWER FROM DC TO AC

| Node | SimPowerSystem results | | Power Flow Results | |
|------|------------------------|----------|--------------------|----------|
| | Mag.(p.u.) | Power(W) | Mag.(p.u.) | Power(W) |

| | | | | |
|----------|---------|---------|---------|---------|
| DC bus 1 | 0.99035 | 1100.73 | 0.99986 | 1094.29 |
| DC bus 3 | 0.98693 | 594.441 | 0.99981 | 593.08 |
| AC bus 1 | 0.98891 | 1023.02 | 0.99009 | 1023.03 |
| AC bus 2 | 0.99090 | 2046.04 | 0.99211 | 2046.07 |
| AC bus 3 | 0.98839 | 511.513 | 0.98957 | 511.52 |

From these two sets of power flow results comparisons for the generation buses, it shows that the calculated values are close to the simulation thus verifies the effectiveness of the proposed algorithm.

V. CONCLUSION

A power flow algorithm suitable for droop controlled LV hybrid AC-DC microgrid has been proposed where the virtual impedance is used in both the AC network, DC network and the interlinking converter. The validation of the proposed power flow algorithm is verified by comparing the results from time domain simulation and that from calculation through this algorithm. Coincidence of the results shows that this power flow algorithm can be used as a tool to analyze the steady state response of the hybrid microgrid which uses droop and virtual impedance as its control strategy.

REFERENCES

- [1] Guerrero, J.M.; Poh Chiang Loh; Tzung-Lin Lee; Chandorkar, M., "Advanced Control Architectures for Intelligent Microgrids—Part II: Power Quality, Energy Storage, and AC/DC Microgrids," Industrial Electronics, IEEE Transactions on , vol.60, no.4, pp.1263,1270, April 2013
- [2] Poh Chiang Loh; Ding Li; Yi Kang Chai; Blaabjerg, F., "Autonomous Control of Interlinking Converter With Energy Storage in Hybrid AC–DC Microgrid," Industry Applications, IEEE Transactions on , vol.49, no.3, pp.1374,1382, May-June 2013
- [3] Loh, Poh Chiang, et al. "Autonomous operation of ac–dc microgrids with minimised interlinking energy flow." IET Power Electronics 6.8 (2013): 1650-1657.
- [4] Nutkani, Inam Ullah, Poh Chiang Loh, and Frede Blaabjerg. "Power flow control of intertied ac microgrids." IET Power Electronics 6.7 (2013): 1329-1338.
- [5] Lu, Xiaonan, et al. "State-of-Charge Balance Using Adaptive Droop Control for Distributed Energy Storage." Xiong Liu; Peng Wang; Poh Chiang Loh, "A Hybrid AC/DC Microgrid and Its Coordination Control," Smart Grid, IEEE Transactions on , vol.2, no.2, pp.278,286, June 2011e Systems in DC Micro-Grid Applications." (2013): 1-1.
- [6] Kamh, M.Z.; Iravani, R., "A Unified Three-Phase Power-Flow Analysis Model For Electronically Coupled Distributed Energy Resources," Power Delivery, IEEE Transactions on , vol.26, no.2, pp.899,909, April 2011
- [7] Abdelaziz, M.M.A.; Farag, H.E.; El-Saadany, E.F.; Mohamed, Y.A.-R.I., "A Novel and Generalized Three-Phase Power Flow Algorithm for Islanded Microgrids Using a Newton Trust Region Method," Power Systems, IEEE Transactions on , vol.28, no.1, pp.190,201, Feb. 2013
- [8] Elrayyah, Ali; Sozer, Yilmaz; Elbuluk, Malik, "A novel load flow analysis for particle-swarm optimized microgrid power sharing," Applied Power Electronics Conference and Exposition (APEC), 2013 Twenty-Eighth Annual IEEE , vol., no., pp.297,302, 17-21 March 2013
- [9] Beerten, J.; Cole, S.; Belmans, R., "A sequential AC/DC power flow algorithm for networks containing Multi-terminal VSC HVDC systems," Power and Energy Society General Meeting, 2010 IEEE , vol., no., pp.1,7, 25-29 July 2010
- [10] Panosyan, A.; Oswald, B. R., "Modified Newton-Raphson load flow analysis for integrated AC/DC power systems," Universities Power Engineering Conference, 2004. UPEC 2004. 39th International , vol.3, no., pp.1223,1227 vol. 2, 8-8 Sept. 2004
- [11] M. W. Mustafa and A. F. A. Kadir, "A modified approach for load flow analysis of integrated ac-dc power systems," in TENCON Proceedings, 2000, pp. 108-113.