



Aalborg Universitet

AALBORG UNIVERSITY
DENMARK

Wireless Indoor Positioning Relying on Observations of Received Power and Mean Delay

Begusic , Stjepan ; Urup , Daniel Nygaard ; Kolonic , Jasmina ; Pedersen, Henrik Holbæk; Wang, Wei; Raulefs, Ronald; Jakobsen, Morten Lomholt; Steinböck, Gerhard; Pedersen, Troels

Published in:
Communications Workshops (ICC), 2013 IEEE International Conference on

DOI (link to publication from Publisher):
[10.1109/ICCW.2013.6649204](https://doi.org/10.1109/ICCW.2013.6649204)

Publication date:
2013

Document Version
Accepted author manuscript, peer reviewed version

[Link to publication from Aalborg University](#)

Citation for published version (APA):
Begusic , S., Urup , D. N., Kolonic , J., Pedersen, H. H., Wang, W., Raulefs, R., Jakobsen, M. L., Steinböck, G., & Pedersen, T. (2013). Wireless Indoor Positioning Relying on Observations of Received Power and Mean Delay. In *Communications Workshops (ICC), 2013 IEEE International Conference on* (pp. 74-78). IEEE. I E E E International Conference on Communications <https://doi.org/10.1109/ICCW.2013.6649204>

General rights

Copyright and moral rights for the publications made accessible in the public portal are retained by the authors and/or other copyright owners and it is a condition of accessing publications that users recognise and abide by the legal requirements associated with these rights.

- ? Users may download and print one copy of any publication from the public portal for the purpose of private study or research.
- ? You may not further distribute the material or use it for any profit-making activity or commercial gain
- ? You may freely distribute the URL identifying the publication in the public portal ?

Wireless Indoor Positioning Relying on Observations of Received Power and Mean Delay

Stjepan Begušić^{*†}, Daniel Nygaard Urup^{*}, Jasmina Kolonić^{*†}, Henrik Holbæk Pedersen^{*}, Wei Wang[‡], Ronald Raulefs[‡], Morten Lomholt Jakobsen^{*}, Gerhard Steinböck^{*}, and Troels Pedersen^{*},

^{*}Section Navigations and Communications (NavCom), Dept. Electronic Systems, Aalborg University, Denmark

[†]Dept. Electronic Systems and Information Processing, Faculty of Electrical Engineering and Computing, University of Zagreb, Croatia

[‡]Institute of Communications and Navigation, German Aerospace Center (DLR), Wessling, Germany

Abstract—This contribution introduces position estimation methods relying on observations of the received power and mean delay obtained in a wideband multi-link scenario. In particular, one- and two-step methods are introduced based on statistical models of the observed link parameters. The proposed methods are tested on data from a wideband measurement campaign. The results show that including observations of mean delay of the wideband links can notably improve positioning accuracy as compared to relying on observations of received power alone.

I. INTRODUCTION

Indoor positioning techniques rely on observations of channel-related parameters obtained from a number of radio-links. These techniques fall in two categories [1]: The first category is the so-called fingerprinting techniques where position estimates are obtained by matching observed channel parameters (called fingerprints) to a prerecorded database. The second category are the model-based techniques where observations of link-parameters are related to geometrical parameters (e.g. distances, directions, position, etc) via models of the radio channel. In this contribution we consider the model-based approaches. Popular link parameters for model-based indoor positioning include the received power and the time-of-arrival (ToA) [2, 3, 4]. The received power can be obtained via the Received Signal Strength Indicator (RSSI) available in most communication systems. However, due to fading of the received power, the derived position estimates are endowed with large errors [2]. In contrast, to obtain ToA estimates accurate enough for indoor positioning very large signal bandwidth is needed; typically, this is only possible in ultra wideband (UWB) systems [2, 3, 4]. Therefore, it remains important to identify link parameters useful for indoor positioning and yet obtainable in communication systems with limited bandwidth.

For a link-parameter to be useful in practical indoor positioning systems, it must be easy to obtain and carry useful information about the position. Examples of such parameters related to link-distance which can be computed in wideband¹ systems include the received power and the first- and second moments of the squared magnitude impulse response, i.e. the mean delay and rms delay. In [5] a distance-dependent model is derived for the delay power spectrum of an in-room channel

¹We consider here the bandwidth of “wideband systems” to be less than that of UWB systems.

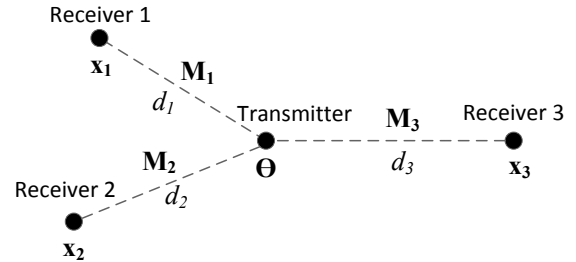

Fig. 1. A positioning scenario with three receivers in known positions ($\mathbf{x}_1, \mathbf{x}_2, \mathbf{x}_3$) and a transmitter in an unknown position Θ . The vector \mathbf{M}_i of distance dependent parameters is obtained from link i .

taking into account effects due to reverberation. From this model, secondary models for other link parameters, such as the average path gain and the mean delay of a radio link, are also derived. From the path gain [which is the inverse of the path loss] the received power can be computed for known transmitted power. It is evident from these secondary models that both mean delay and received power are distance dependent. The mean delay is an attractive link parameter to consider in a positioning context since it can be obtained using both UWB or wideband systems.

In this contribution we consider positioning algorithms relying on measurements of the mean delay and the received power of each link. The methods are derived using the secondary models from [5] modified to include random fluctuations due to multipath propagation. In line with the observations of [6] we model the fluctuations of different links as independent random variables. Moreover, as a first simplifying approximation, we consider fluctuations in the parameters of each single link to be independent. Our modeling is used to propose one-step and two-step positioning algorithms. The derived methods are tested via simulation and by applying them to in-room wideband measurement data. These tests show that including observations of the mean delay yields high accuracy, even in the case of wideband systems.

II. SIGNAL MODEL

An indoor positioning scenario is considered, with K receivers in known positions $\mathbf{x}_1, \mathbf{x}_2, \dots, \mathbf{x}_K$ and a transmitter in an unknown position Θ , as shown in Fig. 1. The transmitter is communicating with the receivers via K radio links. Its

position is estimated using distance dependent link parameters. The observations can be described as random variables, where the mean is predicted by the models. We denote the vector of observed link parameters by $\mathbf{M} = [\mathbf{M}_1, \mathbf{M}_2, \dots, \mathbf{M}_K]$ where \mathbf{M}_i denotes the observations obtained for link i . Each link allows for observations of received power G_i , observed mean delay μ_i or both. This corresponds to the cases, $\mathbf{M}_i = G_i$, $\mathbf{M}_i = \mu_i$, or $\mathbf{M}_i = [G_i, \mu_i]$, respectively. We model the received power (in dB) for link i as:

$$10 \log G_i = 10 \log G(d_i) + \varepsilon_{G,i} \quad (1)$$

where $G(d_i)$ is the average power, predicted by a path loss model and d_i is the distance of link i , i.e. the distance between the transmitter and receiver i . The observation noise $\varepsilon_{G,i}$ is a zero-mean random variable with the same standard deviation σ_G for all links. Similarly, the model for the observed mean delay for link i reads

$$\mu_i = \mu_\tau(d_i) + \varepsilon_{\mu,i}, \quad (2)$$

where $\mu_\tau(d_i)$ is predicted by a mean delay model and the observation noise $\varepsilon_{\mu,i}$ is a zero-mean random variable with the same standard deviation σ_μ for all links.

A. Mean Models for Link Parameters

We apply the models for the received power and mean delay proposed in [5]. These models are both derived from a model of the delay power spectrum of an in-room wideband channel, which is a superposition of a primary component and a component due to reverberation. The secondary models have the same superposition structure. The average power is thus a sum of a primary component and a reverberant component:

$$G(d) = G_0 \left(\frac{d_0}{d} \right)^n + G_0 \frac{R_0}{1 - R_0} e^{-\frac{d_0 - d}{cT}}, \quad (3)$$

where $G(d)$ is the average power at distance d . The parameters of the model are: d_0 (reference distance), G_0 (average power at d_0), R_0 (reverberation ratio at d_0), n (path loss exponent) and T (reverberation time). The constant c is the speed of light. The first term in (3) is due to the primary component, i.e. it accounts for the directly propagating signal and possibly first order reflections with small excess delays. The second term is due to an exponentially decaying diffuse tail of the delay-power spectrum with onset at delay d/c . As a consequence of the distance dependent onset, the second term in (3) decays exponentially with distance. The reverberant component in (3) vanishes when $R_0 = 0$ and the expression becomes equivalent to the well-known one-slope path loss model [7]. The model for mean delay reads

$$\mu_\tau(d) = \frac{d}{c} + TR(d). \quad (4)$$

with reverberation ratio

$$R(d) = \frac{1}{1 + \frac{1 - R_0}{R_0} \left(\frac{d_0}{d} \right)^n e^{-\frac{d - d_0}{cT}}}. \quad (5)$$

This model accounts for the shift in mean delay due to an exponential tail of the delay-power spectrum.

B. Statistical Models for Link Parameters

We analyze the received power residuals and observed mean delay residuals in order to formulate a statistical model for the observations in (1) and (2). As found in [8], received power can be assumed independent for different links. Moreover, it appears from further analysis of the same measurement data that the correlation of observed mean delay residuals between links is small. Received power is typically modeled as log-normal (i.e. Gaussian if taken in dB) [7], which was also confirmed in [8]. Furthermore, the analysis of the observed mean delay residual suggests that mean delay can be modeled as a Gaussian random variable. Therefore, as a first approximation we consider the observations in \mathbf{M} to be independent random variables with joint pdf

$$f_{\mathbf{M}}(\mathbf{M}; \mathbf{d}) = \prod_{i=1}^K f_{\mathbf{M}_i}(\mathbf{M}_i; d_i), \quad (6)$$

where $\mathbf{d} = [d_1, d_2, \dots, d_K]$ and the i th factor is of the form

$$f_{\mathbf{M}_i}(\mathbf{M}_i; d_i) = \begin{cases} f_G(G_i; d_i), & M_i = G_i \\ f_\mu(\mu_i; d_i), & M_i = \mu_i \\ f_G(G_i; d_i) \cdot f_\mu(\mu_i; d_i), & M_i = [G_i, \mu_i] \end{cases} \quad (7)$$

where f_G is the log-normal pdf

$$f_G(G_i; d_i) = \frac{1}{\ln 10 G_i \sigma_G \sqrt{2\pi}} \times \exp\left(-\frac{(10 \log G_i - 10 \log G(d_i))^2}{2\sigma_G^2}\right), \quad G_i > 0 \quad (8)$$

while f_μ is a Gaussian pdf

$$f_\mu(\mu_i; d_i) = \frac{1}{\sigma_\mu \sqrt{2\pi}} \exp\left(-\frac{(\mu_i - \mu(d_i))^2}{2\sigma_\mu^2}\right), \quad (9)$$

with mean $\mu(d_i)$ given by (4) and variance σ_μ^2 .

III. POSITION ESTIMATION

Position estimation can be performed following one of the two approaches: one-step or two-step. In a one-step approach the position θ is estimated directly from the observations \mathbf{M} . In a two-step approach, the distances in the vector \mathbf{d} are first extracted from the observations \mathbf{M} and then used to infer on the position θ . Although two-step methods are typically less accurate, their complexity is lower in comparison to one-step methods. We describe first a one-step maximum likelihood method and then a heuristic two step method. Fig. 2 gives an overview of the algorithms.

First we consider a one-step method where the position θ is directly estimated from the observations \mathbf{M} via the maximum likelihood principle. Writing the distance d_i as a function of the unknown position θ , $d_i(\theta) = \|\mathbf{x}_i - \theta\|_2$, and defining $f_{\mathbf{M}}(\mathbf{M}; \theta) = f_{\mathbf{M}}(\mathbf{M}; \mathbf{d}(\theta))$ with $\mathbf{d}(\theta) = [d_1(\theta), \dots, d_K(\theta)]$, the maximum likelihood estimator for θ reads

$$\hat{\theta} = \arg \max_{\theta} f_{\mathbf{M}}(\mathbf{M}; \theta). \quad (10)$$

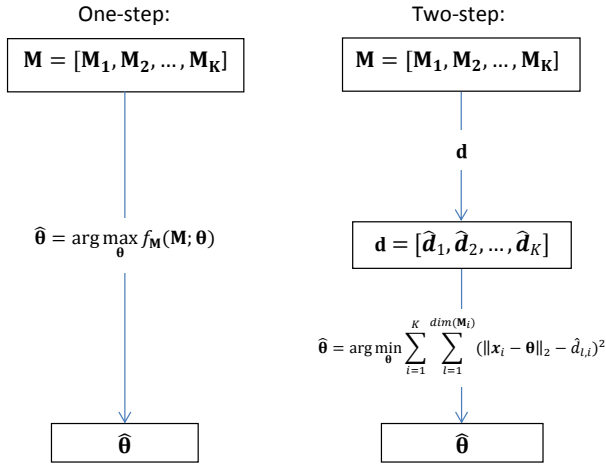

Fig. 2. Overview of the considered one-step (left) and two-step (right) positioning methods.

The complex structure of the likelihood function prohibits an analytical solution to this maximization. Therefore, we resort to numerical optimization techniques. Due to the complexity of the likelihood function and the presence of local maxima, we applied a modified version of the simulated annealing algorithm [9]. This is an iterative method which requires initialization. For this purpose we used the position estimate obtained by the two-step method described in the following.

In the two-step method we first estimate the link distances \mathbf{d} from the observed link parameters \mathbf{M} . The distance d_i can be estimated from the observed power as $G^{-1}(G_i)$ where G^{-1} is the inverse of $G(d)$ in (3) which can be obtained numerically using a root-finding algorithm. In a similar way a distance estimate can be obtained as $\mu_{\tau}^{-1}(\mu_i)$ by inversion of (4). Thus for links with observations of both received power and mean delay, we obtain two distance estimates denoted by $\hat{d}_{1,i}$ and $\hat{d}_{2,i}$, respectively. The estimated link distances are then used for position estimation by solving a heuristically posed least squares problem:

$$\hat{\boldsymbol{\theta}} = \arg \min_{\boldsymbol{\theta}} \sum_{i=1}^K \sum_{\ell=1}^{\dim(\mathbf{M}_i)} (d_i(\boldsymbol{\theta}) - \hat{d}_{\ell,i})^2, \quad (11)$$

where $\dim(\cdot)$ denotes the dimension of the vector given as argument. A solution to the nonlinear least squares problem (11) can be approximated by a Gauss-Newton algorithm [10].

IV. MEASUREMENT DATA

The proposed methods are evaluated using measurement data obtained from an indoor experiment, conducted at the premises of the German Aerospace Center (DLR) [5], [8]. The measurements were taken in a room, depicted in Fig. 3.

The receiver was placed at fixed positions (Rp1 to Rp5), and the transmitter was moving along two tracks (T1 and T2). The positions of the receivers and transmitters were measured with an accuracy of about 1 cm. The environment was static and nobody was in the room during the measurements gathering. The measurements for different receiver positions were

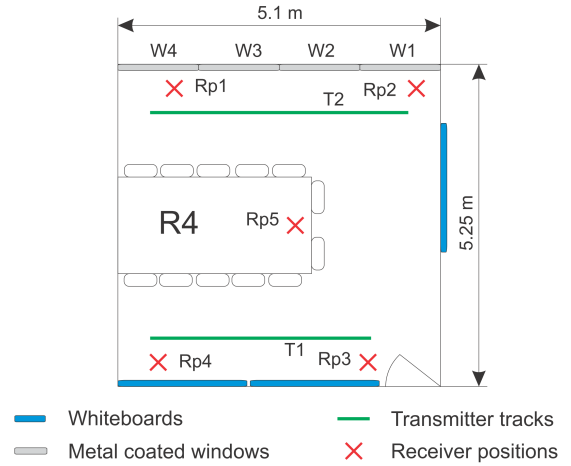

Fig. 3. Schematic of the room where the experiment took place.

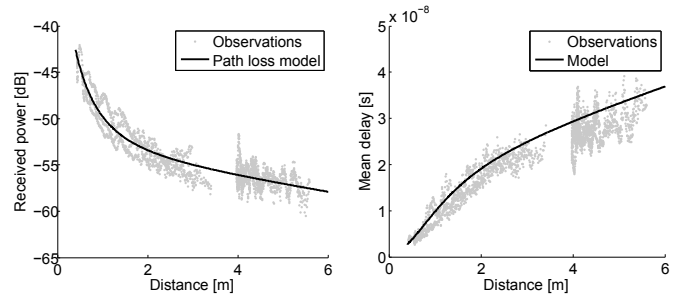

Fig. 4. Observed power (left), mean delay (right). Parameter values of fitted mean models. $G_0 = 6.85 \cdot 10^{-6}$, $n = 2.2$, $R_0 = 0.35$, $T = 18.4$ ns. Estimated standard deviations: $\hat{\sigma}_G = 0.93$ [dB], and $\hat{\sigma}_\mu = 2.57$ [ns], respectively.

collected sequentially. They are combined according to the respective transmitter positions to obtain a set of multi-link measurements for the positioning application.

The used transmit antenna was omni-directional. At the receiver a uniform circular array with 8 monopoles was used. The transmitter and receiver antenna heights were 1.26 m and 1.1 m, respectively. The transmitter and the receiver were synchronized via cables to a common clock. The channel transfer function for a bandwidth of 120 MHz and a carrier frequency of 5.2 GHz was measured [8].

Similar to [5], the magnitude squared samples of the channel transfer function are averaged over the entire frequency band and the 8 receiver antennas to obtain an estimate of the received power. After filtering the channel transfer function with a Hann window we apply the inverse discrete Fourier transform to obtain estimates of the channel impulse responses. We take the average of the magnitude squared channel impulse responses for the 8 receiver antennas to obtain an estimate of the delay power spectrum. From the estimated delay power spectrum we estimate the mean delay in [5]. The models (3) and (4) were fitted to the measurement data using non-linear least-squares techniques. The obtained results are reported in Fig. 4.

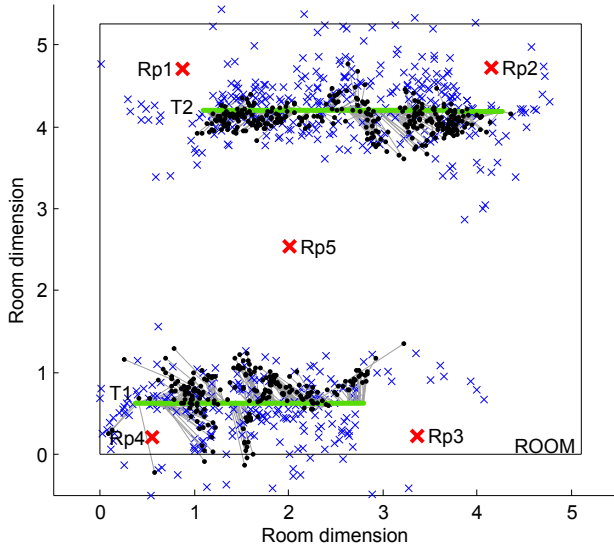

Fig. 5. Position estimates of the one-step algorithm in a simulated scenario for two cases of observed link parameters \mathbf{M}_i : Blues crosses: received power, i.e., $\mathbf{M}_i = G_i$. Black dots: mean delay observations, i.e., $\mathbf{M}_i = \mu_i$. Grey lines: errors for the $\mathbf{M}_i = \mu_i$ case.

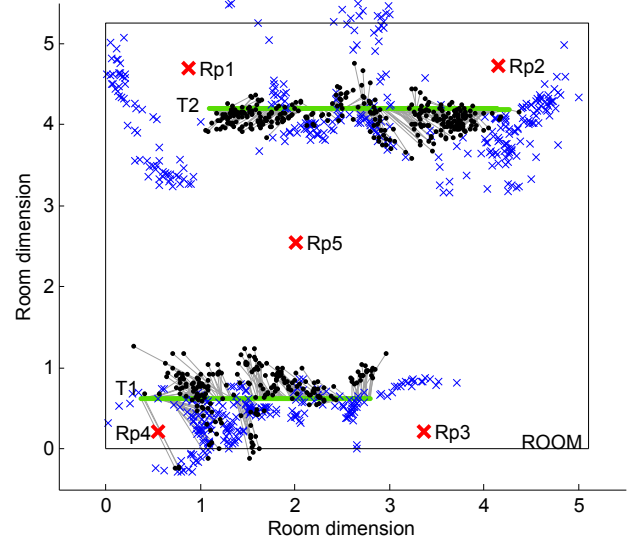

Fig. 6. Position estimates of the one-step algorithm for measurement data for two cases of observed link parameters \mathbf{M}_i : Blues crosses: received power, i.e., $\mathbf{M}_i = G_i$. Black dots: mean delay observations, i.e., $\mathbf{M}_i = \mu_i$. Grey lines: errors for the $\mathbf{M}_i = \mu_i$ case.

V. RESULTS

The proposed one- and two-step positioning methods were tested by applying them to measurement and simulation data. The resulting positioning errors are computed as the Euclidean distance between the estimated and the true position of the transmitter. In the simulations, the observations of received power and mean delay are generated for the scenario with receiver and transmitter positions as in Fig. 3 by the statistical models defined in Subsection II-B. The results are reported in the empirical cdfs of the position error for the proposed methods, for measured data in Fig. 8 and for the simulations in Fig. 7. The results are summarized in terms of the root mean squared error (RMSE) in Table I.

The simulation results in Fig. 5 and Fig. 7 demonstrate that both one- and two-step methods work for the considered statistical model. Moreover, as expected, some performance loss in terms of accuracy results from using the two-step method. For both one- and two-step methods, it is apparent that between the two considered types of link parameters, the power observation is least and mean delay is the most informative. It also appears from Fig. 7 that the gain in accuracy by including both types of observations in the estimator, is modest compared to positioning relying on mean delay only.

The results in Fig. 6 and Fig. 8 obtained for the measurement data are very similar to the simulation results. However, the improvement that hybrid methods (i.e. with observation of both received power and mean delay) have compared to methods using only mean delay is less pronounced than in the simulation data. The effect is also visible in the RMSE values in Table I. The RMSE obtained by the one-step method for mean delay observations alone is 0.34 m which is only reduced by mere 1 cm by taking received power into account in addition. It seems plausible to attribute a part of this effect

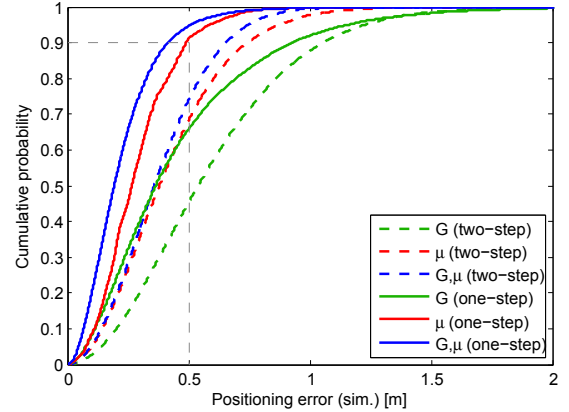

Fig. 7. Empirical cdfs of the positioning errors from simulation data.

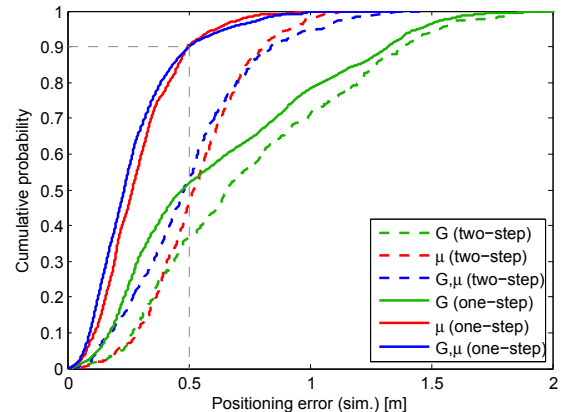

Fig. 8. Empirical cdfs of the positioning errors from measurement data.

TABLE I
ROOT MEAN SQUARED ERRORS OF POSITION ESTIMATES AND
ALGORITHM RUNTIMES

Method	M_i	RMSE [m]		Runtime [s]
		meas.	sim.	
Two-step	G	0.87	0.68	0.63
Two-step	μ	0.57	0.49	0.44
Two-step	G, μ	0.57	0.43	1.44
One-step	G	0.77	0.58	4.20
One-step	μ	0.34	0.33	2.24
One-step	G, μ	0.33	0.28	4.50

to the approximation of statistically independent observations of mean delay and power. Moreover, it seems that considering only observed power, that the estimators return larger errors as compared to the simulations. This may indicate that the model for the received power could be refined, i.e. a better suited model than the log-normal fading should be considered.

The obtained RMSE is remarkably low for indoor positioning when considering the 120 MHz bandwidth of the sounding signal. At this bandwidth, first order reflections interfere with the direct signal which leads to poor performance of ToA estimators [3]. This effect is less severe for mean delay estimation. This observation demonstrates the value of mean delay observation for positioning algorithms using data from wideband systems. The performance of the mean delay estimator and its impact on the positioning accuracy should be further investigated to conclude on how much the performance degrades if the signal bandwidth is reduced.

To provide a rough comparison of the relative computational demand of each of the methods, runtimes for Matlab implementations of each of the methods are given in I. The reported runtimes are averages of ten runs on a standard PC. One run includes position estimation of all points on both tracks using measurement data.

VI. CONCLUSION

In this contribution we considered in-room positioning utilizing observations of received power and mean delay. This work relies on the delay power spectrum model and the secondary models of path gain and mean delay [5]. These models predict the mean of the link parameters and were extended to include observation noise due to multipath propagation. As a starting point, we modeled the observations of path gain and mean delay to be statistically independent. This assumption was made for reasons of simplicity. Based on this model we investigated two different methods for positioning: A one-step method where the position is directly obtained from the measurements via a maximum-likelihood estimator, and a two-step method where the position is obtained from distances estimated from each link.

The proposed methods were tested on data from a wideband measurement campaign. The experiment was carried out using a signal bandwidth of 120 MHz. The results show that the mean delay parameter improves the positioning accuracy in comparison to methods relying on observations of received

power only. In the considered set-up, relying on power only the one-step method could achieve a root mean squared error of 0.77 m; for mean delay the corresponding number is 0.34 m. Using observations of both power and mean delay lowers the RMSE to 0.33 m, i.e. by only 1 cm. It thus seems that the mean delay data is very informative for estimation of position. This conclusion is remarkable, in particular when compared to the long pulse duration for the sounding signal used in the measurement. Further work is needed in order to yield insight into how the bandwidth affects the positioning accuracy when relying on the mean delay.

ACKNOWLEDGMENT

This work was co-funded by the European Union via the project ICT- 248894 Wireless Hybrid Enhanced Mobile Radio Estimators 2 (WHERE2).

REFERENCES

- [1] E. Falletti and M. Luise, "Review of satellite, terrestrial outdoor, and terrestrial indoor positioning techniques," tech. rep., Newcom++, 2008.
- [2] H. Liu, H. Darabi, and P. Banerjee, "Survey of wireless indoor positioning techniques and systems," *IEEE Trans. Syst. Man and Cybernetics*, vol. 37, no. 6, pp. 1067–1080, 2007.
- [3] N. Alsindi, B. Alavi, and K. Pahlavan, "Measurement and modeling of ultrawideband TOA-based ranging in indoor multipath environments," *IEEE Trans. Vehicular Techn.*, vol. 58, pp. 1046–1058, Mar. 2009.
- [4] A. Conti, M. Guerra, D. Dardari, N. Decarli, and M. Z. Win, "Network experimentation for cooperative localization," *IEEE J. on Selected Areas in Commun.*, vol. 30, pp. 467–475, Feb. 2012.
- [5] G. Steinböck, T. Pedersen, B. H. Fleury, W. Wang, and R. Raulefs, "Distance dependent model for the delay power spectrum of in-room reverberant channels," 2012.
- [6] W. Wang, G. Steinböck, T. Jost, T. Pedersen, R. Raulefs, and B. Fleury, "Channel Measurements and Characteristics for Cooperative Positioning Applications," in *International Conference on Localization and GNSS (ICL-GNSS)*, pp. 1–5, IEEE, 2012.
- [7] T. S. Rappaport, *Wireless Communications Principles and Practice*. Prentice Hall, 2002.
- [8] G. Steinböck, T. Pedersen, and W. Wang, "AAU-DLR 2010 indoor measurement campaign: Measurements for validation of models for reverberant and cooperative channels," tech. rep., Aalborg University, 2011.
- [9] M. Fleischer, "Simulated annealing: Past, present, and future," in *Proc. of the 1995 Winter Simulation Conference*, 1995.
- [10] Å. Björck, *Numerical methods for least squares problems*. Siam, 1996.