



Aalborg Universitet

AALBORG UNIVERSITY  
DENMARK

## Optimal placement of MIMO antenna pairs with different quality factors in smart-phone platforms

Tatomirescu, Alexandru; Arabadi, Osama; Pedersen, Gert Frølund

*Published in:*  
Antennas and Propagation (EuCAP), 2013 7th European Conference on

*Publication date:*  
2013

*Document Version*  
Early version, also known as pre-print

[Link to publication from Aalborg University](#)

*Citation for published version (APA):*  
Tatomirescu, A., Arabadi, O., & Pedersen, G. F. (2013). Optimal placement of MIMO antenna pairs with different quality factors in smart-phone platforms. In *Antennas and Propagation (EuCAP), 2013 7th European Conference on* (pp. 732 - 735). European Conference on Antennas and Propagation (EuCAP).

### General rights

Copyright and moral rights for the publications made accessible in the public portal are retained by the authors and/or other copyright owners and it is a condition of accessing publications that users recognise and abide by the legal requirements associated with these rights.

- ? Users may download and print one copy of any publication from the public portal for the purpose of private study or research.
- ? You may not further distribute the material or use it for any profit-making activity or commercial gain
- ? You may freely distribute the URL identifying the publication in the public portal ?

### Take down policy

If you believe that this document breaches copyright please contact us at [vbn@aub.aau.dk](mailto:vbn@aub.aau.dk) providing details, and we will remove access to the work immediately and investigate your claim.

# Optimal Placement of MIMO Antenna Pairs with Different Quality Factors in Smart-Phone Platforms

Alexandru Tatomirescu, Osama Alrabadi, Gert F. Pedersen

Section of Antennas, Propagation and Radio Networking (APNet), Department of Electronic Systems,  
Faculty of Engineering and Science, Aalborg University, DK-9220 Aalborg, Denmark  
{ata, ona, gfp}@es.aau.dk

**Abstract**—In this contribution, an investigation on the use of tunable antennas for a compact implementation of multi input multi output (MIMO) phones has been done. The position of the exciting elements has been investigated as well as the antenna's bandwidth impact on the mutual coupling.

It has been shown that generally narrow band antennas have increased inherent isolation and in some special cases they can have impressive levels of isolation. A two by two MIMO system has been considered and the influence of the user has not been investigated. A design for a compact MIMO tunable antenna is proposed with good performance without the increased complexity of a decoupling technique.

## I. INTRODUCTION

One of the current challenges for antenna designs for handheld devices destined to be used in 4G Mobile Networks is covering the low bands for spatial multiplexing operation. It has been shown in [1] that using the multi-path properties of the wireless channel, parallel data streams can be achieved thus increasing the capacity almost linearly with the number of streams.

The fundamental limits of small antennas are well known. In 1947, Wheeler proved in [2] that there must be a tradeoff between the size of the antenna, bandwidth and efficiencies. When it comes to compact handsets, the volume allocated to the antenna is minimal therefore the design requirements are to cover efficiently as many bands as possible with the smallest space possible.

The (MIMO) antenna in small and compact handheld terminal, such as mobile phones, is severely constrained by the effect of mutual coupling between the antenna's elements. Due to the fact that the elements are closely spaced, there is a strong electromagnetic interaction between them. The transfer of energy from one element to another is increased when the device becomes electrically small [3] thus degrading the array's performance [4]. Therefore, some of the most challenging bands to design a multi element antenna system are the lower bands used for Long Term Evolution (LTE).

Several techniques for reducing the cross coupling have been investigated in the literature yet most of the proposed methods negatively affect the antenna bandwidth (matching and decoupling bandwidths [4]). Among the available solutions to reduce the effects of mutual coupling presented in literature is the so-called decoupling network as described in [4]. It can be implemented using different mechanisms such as the hybrid-coupler in [5], with microstrip lines as in [6] or using the structure of the antenna itself, as in [7] and [8]. The

drawbacks of this method is the severe decrease in system bandwidth and the added ohmic losses [4]. Other contributions suggest the use of a balanced antenna combined with a conventional design (in [9] and [10]) or the use of a parasitic element [11].

In this contribution, a configuration comprised of two tunable antennas is investigated for optimal MIMO operation (maximum efficiency, minimum coupling and acceptable level of envelope correlation) in a low LTE band. The optimal antenna placement is investigated jointly with the antenna Quality (Q) factor. The rest of the paper is organized as follows: Section II describes the design of the antenna element being investigated as well as the search methodology for a good MIMO antenna. Section III provides simulation results followed by a short discussion. Finally, Section IV concludes the paper.

## II. METHODS AND ANTENNA DESIGN

The antenna element used for this analysis is an meandered inverted L antenna (ILA) in two configurations, the structures from figure 1. Among the design criteria were compactness, simplicity, low band operation and tunability. The resonant frequency of each element is around 1 GHz however, capacitive loading of the antennas is used to lower their resonance frequency and to obtain tunability. The simulation has been carried out using a commercial Finite-Difference Time-Domain (FDTD) electromagnetic solver. In the simulations with losses included, the conductor has been modeled with copper and the tuning capacitor has been modeled as having a Q of 150.

Two exciting element designs are investigated, the difference between them is their Q factor. The different bandwidths are obtained by extending the length of the antenna. The low Q element is longer with 10 mm and has one extra meander.

There are five antenna position configurations which have been analyzed and for the sake of clarity, acronyms have been assigned to each of them, as illustrated in figure 2. They are the two classical top and bottom case, with opposite and same side feeding (TBO and TBS), as well as three cases with a side placement. The latter include opposite sides and top feeding (STO), same side with top and bottom feeding (STB) and opposite sides with top and bottom feeding (OSTB).

The antenna element chosen for this investigation has a strong capacitive behavior so, in order to reduce the impedance mismatch, it must be compensated with a parallel inductance.

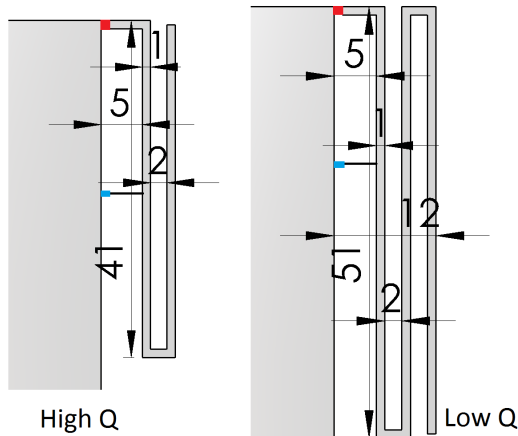

Fig. 1. The numerical model of the structures in free-space. The excitation ports are marked with red. The capacitors are marked with blue.

In order to limit the number of variations in the design and thus the number of simulations, this needed inductance has been simulated as a 3.1 nH lumped inductor in parallel at the feeding point.

The size of the ground plane is considered to be the smart phone size, more precisely 110 by 55 mm. There is no substrate for the ground plane included in simulation, only the conductor is simulated. The exact dimensions of the elements are shown in figure 1 and the area occupied by one element is  $9 \times 41 \text{ mm}^2$  for the high Q element, respectively  $12 \times 51 \text{ mm}^2$  for the low Q one.

The mechanism to minimize the coupling between antenna elements, proposed in this contribution, is inspired from the fact that narrow-band antennas have a more concentrated near-field distribution compared to wide-band antennas. Furthermore, by exciting the antenna chassis modes in different positions, a reasonable level of isolation is can archived as it will be illustrated further.

### III. DISCUSSIONS AND RESULTS

Each element has been designed to be able to service the LTE lower bands, from 698- 950 MHz, just by varying the loading capacitance. The tuning steps of the capacitor are dictated by the technology used in the implementation. However, by adjusting the distance of the capacitor from the feeding point, one can find the required position so that the available tuning step is small enough to cover the entire frequency interval of interest. In the case presented here, a step of 0.11 pF is required to cover the entire frequency interval from 680 to 960 MHz, as in can be seen in figure 3. It must be noted that the results correspond to a lossless simulation therefore, the last two tuning steps will have a better matching due to the significantly higher losses at that frequency.

The input impedance of the antenna element, when it is alone on the PCB, does not change significantly depending on its position (from the cases in figure 2). However, in a two element configuration this is no longer the case. Depending on the position of the two elements and on how well the antennas couple to the PCB ground plane, the coupling between the antennas modifies the port input impedance drastically.

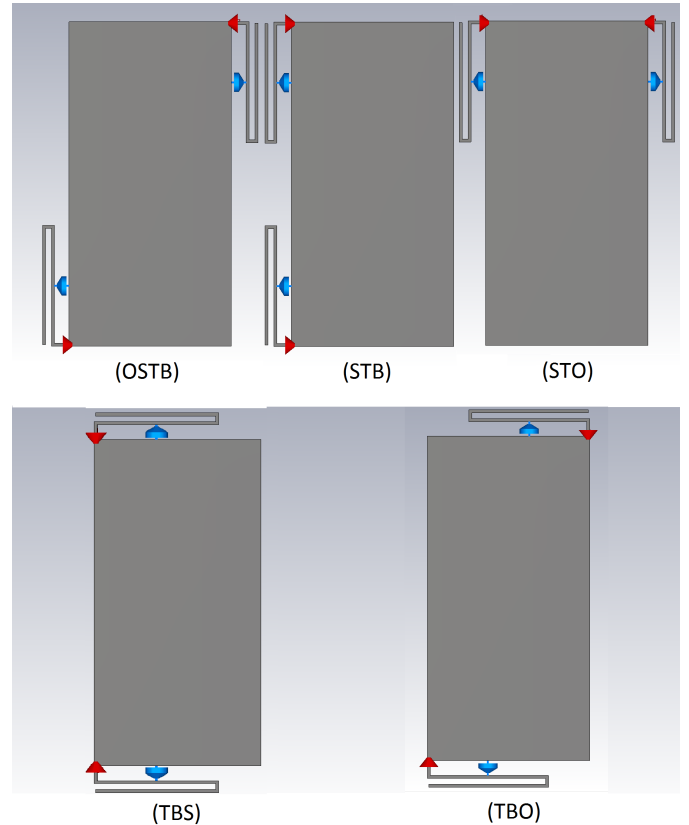

Fig. 2. The position scenarios considered in this contribution and their notations. The red symbol represent the feeding ports and the blue one represents the capacitor.

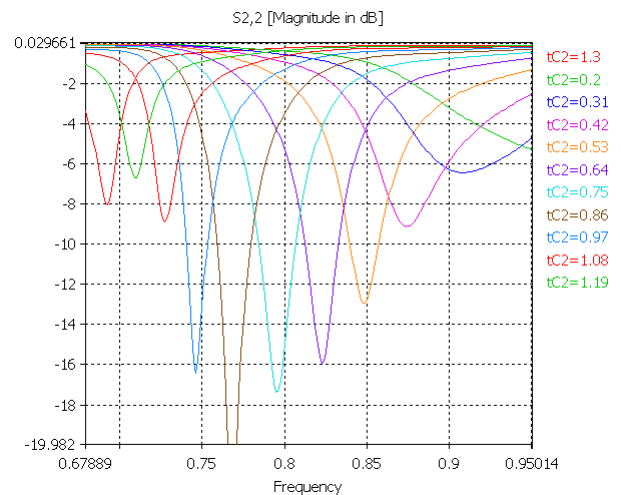

Fig. 3. Input reflection coefficient of one high Q element alone on the PCB for different values of the tuning capacitor in a lossless simulation.

In this investigation, the most clear example of this effect is the case STB with low Q elements, shown in figure 5. In this case the impedance bandwidth doubles due to the fact the second antenna appears as a second resonating mode of the GND plane for the first port and viceversa. Because there is a high coupling between the elements themselves and between each element and the ground plane, the currents induced by each port have as second resonating path.

TABLE I

THE SIMULATED Q AT 700 MHz FOR THE TWO TYPES OF ELEMENTS IN DIFFERENT PLACEMENT CASE FOR LOSSLESS SIMULATIONS.

Cases	TBS	TBO	STO	STB	OSTB
Low Q	17.3	15.8	21.8	7.1	15.9
High Q	46.6	48.2	63.6	19.4	38.7

Despite this fact, the coupling between the elements of MEA can have a detrimental effect on the impedance bandwidth. It has been shown in [12], that due to the chassis modes, the impedance bandwidth in the classical top and bottom configuration (TBO and TBS in this contribution) is lower than in the case where the antennas are placed on the sides (STO,STB and OSTB). The results obtained here confirm this trend. In table I is shown the simulated Q obtained by perfectly matching the antenna and then using the -7 dB bandwidth for a lossless simulation.

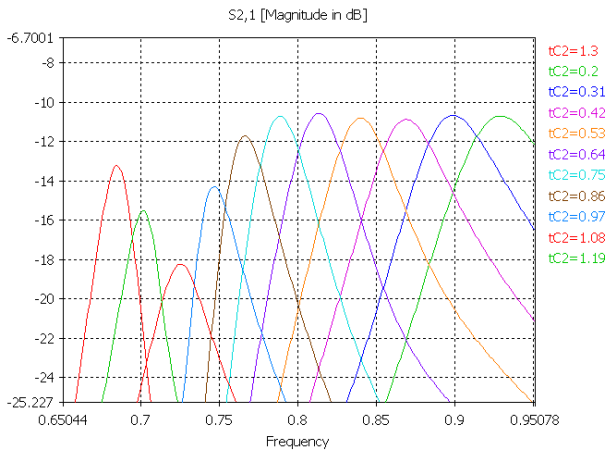

Fig. 4. The simulated  $S_{21}$  for the STO configuration with high Q elements and a lossless simulation for different capacitor values.

The isolation between the elements of the MIMO array is improved by using narrow band elements. Naturally the more confined near-fields of the antennas offer a better isolation, as it was argued also in [13]. However, at low frequencies where the PCB is the main radiator, the best way to increase isolation is to properly excite the antenna chassis.

In the configuration STO, by using narrow band antennas the opposite sides of the PCB are excited thus obtaining a high level of isolation even when the antennas are tuned at 700 MHz, as it can be seen figure 4. The results from table II indicate that a more wide-band antenna will still behave acceptable with this side placement configuration although the performance is degraded. The more the current distributions of the elements overlap, the more coupled they will be, as illustrated by the normalized current distribution plotted in figure 7. At 725 MHz, where the maximum isolation is achieved, we can observe the minimum amount of current exciting the horizontal mode of the chassis.

The losses in the antenna always help the isolation nevertheless, this is a very expensive way to obtain isolation. In table II, the worst case isolation represent the value of the highest coupling from a frequency band around 700 MHz.

In order to have a good MIMO performance, it has been

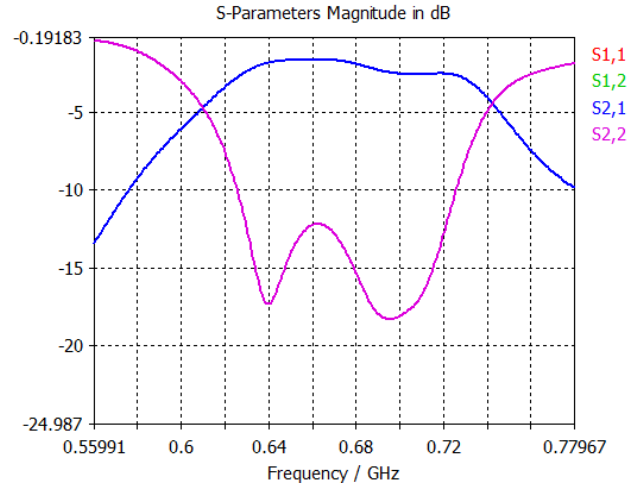

Fig. 5. The S parameters from the lossless simulation of the low Q elements in STB configuration. Only one set of parameters is visible due to symmetry.

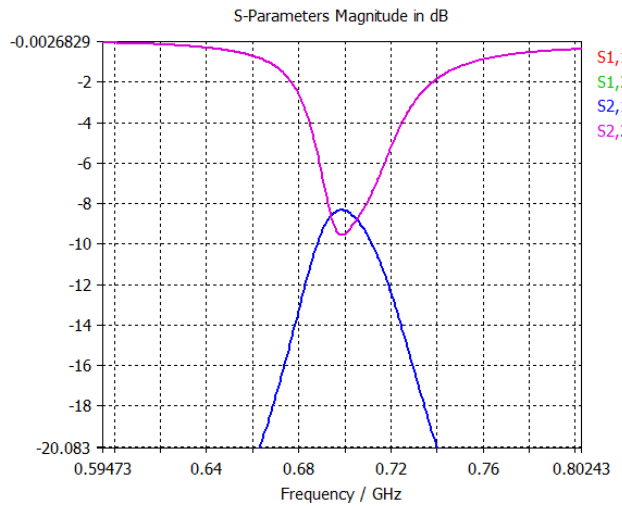

Fig. 6. The S parameters from the lossless simulation of the low Q elements in STO configuration. Only one set of parameters is visible due to symmetry.

shown in [14], that an similar and high mean effective gain (MEG) is required. Furthermore, a low correlation between the port signals is also needed however, when the two MEG are low or very different, then correlation does not have a real impact on the performance. It becomes important in the case with high and similar MEG. However, when it comes to the issue of small handsets, the presence of the human user has decorrelating effects [14].

The envelope correlations coefficient shown in table II have been calculated for isotropic environments and using the radiation patterns. Nevertheless, the parameter of most interest finally will be the efficiency. It is well known the high Q antennas will mean higher currents and thus higher losses however, the exact loss mechanism of high tannable high Q antennas is still the subject of ongoing investigations. From the results show in table II, it is clear that use of narrow band antennas will affect efficiency still, the overall performance is better compared to low Q ones because of the reduced

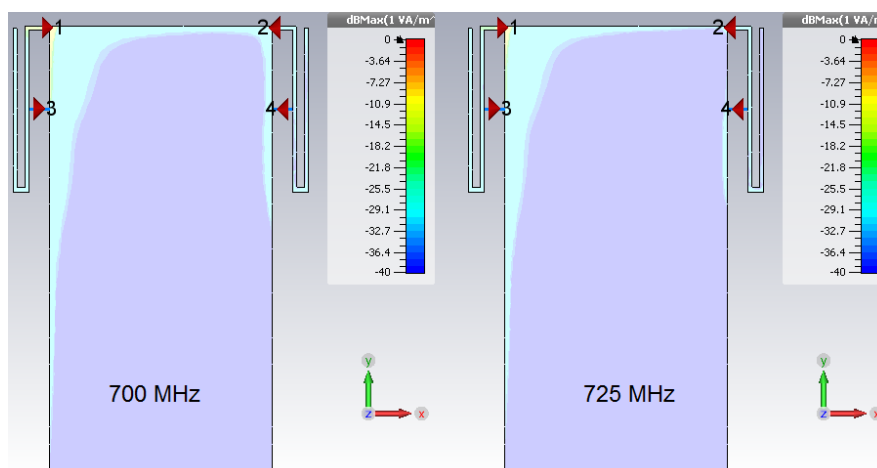

Fig. 7. Simulated normalized current distribution for the STO configuration with high Q elements at 700 MHz (left) and 725 MHz (right).

TABLE II

SIMULATION RESULTS FOR DIFFERENT POSITIONS AROUND THE PCB WITH LOSSES INCLUDED FOR THE CASE WHEN THE ANTENNAS ARE TUNED TO 700 MHz.

Cases	Worst case isolation (dB)		Envelope correlation coeff.		Radiation efficiency (dB)	
	Low	High	Low	High	Low	High
Q						
TBS	-2.2	-3.1	0.68	0.72	-4.5	-5.1
TBO	-2.0	-2.9	0.48	0.52	-4.9	-5.3
STO	-9	-17.1	0.12	0.02	-2.1	-3.8
STB	-3.0	-3.6	0.51	0.41	-3.9	-4.3
OSTB	-1.9	-2.9	0.81	0.63	-5.0	-5.6

coupling which is the main source of losses in the other cases. The effect of the user has not been considered here although studies like the one in [13] show that it will have a major impact on the performance of final products.

#### IV. CONCLUSIONS AND FINALE REMARKS

In this paper, the use of tunable MIMO antenna elements has been investigated through two element designs and five placement configurations. It has been shown that more narrow band elements will have a better isolation nevertheless, this comes at the price of having an increased complexity of the antenna tuning mechanism. The higher losses pose a interesting design challenge.

By carefully choosing the position and coupling mode to the chassis, it is possible to have a sufficient level of isolation so that a good MIMO performance can be achieved. The added benefit of high Q antennas is that the occupied volume can be reduced although in this paper no attempt has been taken to do so. With the current advances in tunable capacitors technologies, it seems that tunable antennas will make their way into most of products in the near future.

From the input impedance bandwidth point of view, the most detrimental position is to have the antennas top and bottom. Tendencies by phone manufacturers in practice are to prefer this configuration due to design limitations. Against mainstream practices, a side placement of the radiators will improved the performance however, it will be more exposed the the user influence.

#### REFERENCES

- [1] G.J. Foschini and M.J. Gans, "On Limits of Wireless Communications in a Fading Environment when Using Multiple Antennas", *Wireless Personal Communications*, NO.6: 311-335, 1998.
- [2] Wheeler, H.A., "Fundamental Limitations of Small Antennas", *Proceedings of the IRE*, vol.35, no.12, pp. 1479- 1484, Dec. 1947
- [3] J. Wallace and M. Jensen, "Mutual Coupling in MIMO Wireless Systems: A Rigorous Network Theory Analysis", *IEEE Transactions on Wireless Communications*, VOL. 3, NO. 4, july 2004.
- [4] B. Lau, J. B. Andersen, G. Kristensson and A. F. Molisch, "Impact of Matching Network on Bandwidth of Compact Antenna Arrays", *IEEE Transactions on Antennas and Propagation*, november 2006, VOL. 54, NO. 11.
- [5] R. Bhatti, S. Yi, and S. Park, "Compact Antenna Array With Port Decoupling for LTE-Standardized Mobile Phones", *Antennas and Wireless Propagation Letters*, IEEE, VOL. 8, 2009
- [6] J.C. Coetzee, and Yu Yantao, "Port Decoupling for Small Arrays by Means of an Eigenmode Feed Network", *IEEE Transactions on Antennas and Propagation*, june 2008.
- [7] A. Diallo, C. Luxey, P. Le Thuc, R. Staraj and G. Kossiavas, "Study and Reduction of the Mutual Coupling Between Two Mobile Phone PIFAs Operating in the DCS1800 and UMTS Bands", *IEEE Transactions on Antennas and Propagation*, VOL. 54, NO. 11, november 2006.
- [8] G. Park, M. Kim, T. Yang, J. Byun and A.S Kim, "The compact quad-band mobile handset antenna for the LTE700 MIMO application", *Antennas and Propagation Society International Symposium*, IEEE 2009. APSURSI '09.
- [9] J. Ilvonen, O. Kiveks, A. A.H Azremi, R. Valkonen, J. Holopainen, and P. Vainikainen, "Isolation Improvement Method for Mobile Terminal Antennas at Lower UHF Band", *Proceedings of the 5th European Conference on Antennas and Propagation (EuCAP)*.
- [10] Zhen Hua Hu, P.S. Hall, P. Gardner, Y. Nechayev, "Wide tunable balanced antenna for mobile terminals and its potential for MIMO applications," *Antennas and Propagation Conference (LAPC)*, 2011 Loughborough, vol., no., pp.1-4, 14-15 Nov. 2011 doi: 10.1109/LAPC.2011.6114131
- [11] B. K. Lau and J. B. Andersen, "Simple and Efficient Decoupling of Compact Arrays with Parasitic Scatterers", *IEEE Transactions on Antennas and Propagation*, 2011.
- [12] A. Krewski, W.L. Schroeder, K. Solbach, "Bandwidth limitations and optimum low-band LTE MIMO antenna placement in mobile terminals using modal analysis," *Proceedings of the 5th European Conference on Antennas and Propagation (EuCAP)*, pp.142-146, 11-15 April 2011
- [13] M. Pelosi, M.B. Knudsen, G.F. Pedersen, "Multiple Antenna Systems With Inherently Decoupled Radiators," *Transactions on Antennas and Propagation*, IEEE, vol.60, no.2, pp.503-515, Feb. 2012
- [14] B. Yanakiev, J.O. Nielsen, M. Christensen, G.F. Pedersen, "Antennas in real environments," *Proceedings of the 5th European Conference on Antennas and Propagation (EuCAP)*, pp.2766-2770, 11-15 April 2011