



Aalborg Universitet

AALBORG UNIVERSITY
DENMARK

COST IC1004 Temporary Document: Characterization of Interference for Over the Air Terminal Testing

Nielsen, Jesper Ødum; Pedersen, Gert Frølund; Fan, Wei

Publication date:
2013

Document Version
Accepted author manuscript, peer reviewed version

[Link to publication from Aalborg University](#)

Citation for published version (APA):

Nielsen, J. Ø., Pedersen, G. F., & Fan, W. (2013). *COST IC1004 Temporary Document: Characterization of Interference for Over the Air Terminal Testing*. Paper presented at COST IC1004 European Cooperation in Science and Technology, Ilmenau, Germany.

General rights

Copyright and moral rights for the publications made accessible in the public portal are retained by the authors and/or other copyright owners and it is a condition of accessing publications that users recognise and abide by the legal requirements associated with these rights.

- ? Users may download and print one copy of any publication from the public portal for the purpose of private study or research.
- ? You may not further distribute the material or use it for any profit-making activity or commercial gain
- ? You may freely distribute the URL identifying the publication in the public portal ?

Take down policy

If you believe that this document breaches copyright please contact us at vbn@aub.aau.dk providing details, and we will remove access to the work immediately and investigate your claim.

EURO-COST

SOURCE: Antennas, Propagation and Radio Networking
Aalborg University
Denmark

Characterization of Interference for Over the Air Terminal Testing

Jesper Ødum Nielsen
Aalborg University, APNet
Niels Jernes Vej 12
9220 Aalborg
DENMARK
Phone: +45 9940 8680
Fax:
Email: jni@es.aau.dk

Characterization of Interference for Over the Air Terminal Testing

Jesper Ødum Nielsen, Gert Frølund Pedersen, Wei Fan

Abstract—The purpose of so-called over the air (OTA) testing of various MIMO devices is to include in the test the properties of both the antenna system as well as the transceiver. In the development of test procedures, much of the focus has been on modeling the properties of the radio channel of the desired signal. However, interfering signals also needs to be considered. The aims of the work described in this contribution is firstly to determine the level of the interference with respect to the desired signal and, secondly, to determine suitable interfering power distribution models, depending on the spherical angle.

To this end, a small series of measurements has been carried out using a spectrum analyzer and a dual-polarized horn antenna. The horn was attached to a programmable device which can point the horn into arbitrary directions on a sphere centered at a given location. For each geographical measurement location a full dual-polarized scan was performed, covering the sphere in azimuth angle and most in elevation angle.

Different locations were investigated, namely rural, sub-urban, and urban, all outdoors. The spectrum from 500–3000 MHz was measured in steps of about 350 kHz.

I. INTRODUCTION

The most realistic way to test MIMO devices is to test them as they are used in realistic scenarios. MIMO over the air (OTA) testing, which is considered as a promising solution to evaluate MIMO device performance in realistic situations, has attracted huge interest from both industry and academia [1]. Standardization work for the development of the MIMO OTA test methods is ongoing in CTIA, 3GPP and COST IC1004.

Many different MIMO test methods have been proposed which vary widely in how they emulate the propagation channel. Size and cost of the testing system are also quite different for various proposals. An overview of different test methodologies under consideration was presented in [2].

In the development of test procedures, much of the focus has been on modeling the properties of the radio channel of the desired signal, see for example [3]. However, interfering signals also need to be considered, but the question arises how this should be modeled in test setups, see *e.g.*, [4]. For the purpose of the current work two general types of interference are considered, as follows.

Background interference, consisting of various kinds of natural and man-made noise and signals that are not specifically allocated the frequency band of interest. Examples of this are electrical noise by engines and switches, spurious emissions by microwave ovens and transmitters, *etc.*, and out of band emissions from transmitters intended for other bands.

J. Ø. Nielsen, G. F. Pedersen, and W. Fan are with the Antennas, Propagation and Radio Networking section at the Department of Electronic Systems, Faculty of Engineering and Science, Aalborg University, Denmark.

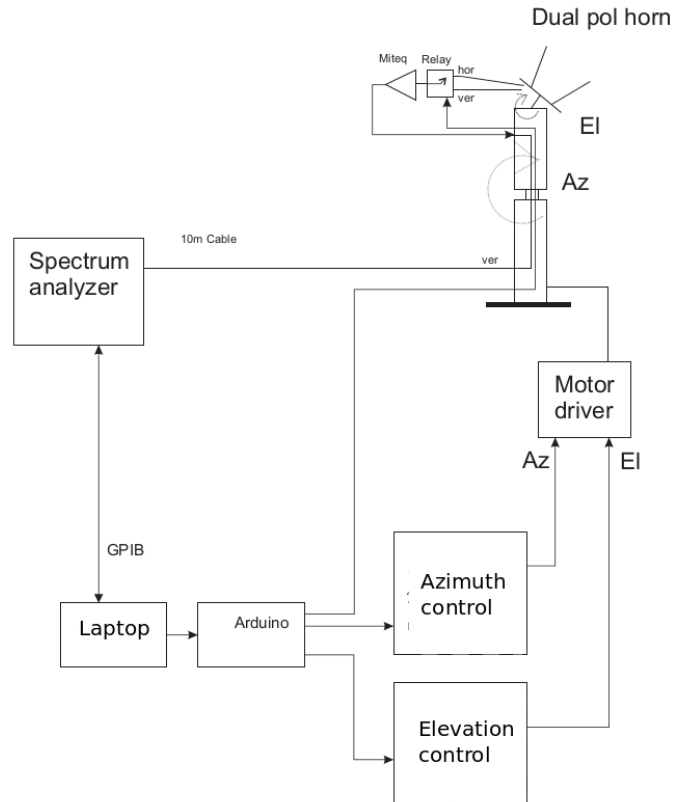

Fig. 1. Block diagram of measurement system.

Co-channel interference comes from Tx'es inside the same system being considered. For example, a mobile station receiving from other BS'es than the serving BS one. This kind of interference is signals of the same or similar type as the desired signal, and often will have the same type of propagation conditions, perhaps with more path loss. In other words, the co-channel interference can to a large extent be modeled in similar ways as the desired signal.

The current work focus on the background interference, with the aim of determining levels and spherical power distribution for mobiles located in various environments. Results from initial measurements are presented that have been carried out in order to obtain an overview of the systems and bands used in the area.

II. MEASUREMENTS

The measurements were carried out using the setup illustrated in the block diagram shown in Fig. 1. A horn antenna



Fig. 2. The dual-polarized horn antenna mounted on the pedestal controlling the direction of the horn.

is connected to a spectrum analyzer through a relay for polarization selection, followed by an amplifier.

The horn antenna is mounted on a pedestal capable of steering the horn in both azimuth angle and elevation angle, controlled by stepper motors under software control. Fig. 2 shows the horn mounted on the pedestal. The pedestal and horn antenna are put on a car trailer, hooked up to the measurement van within which the other parts of the measurement equipment are placed.

For each measurement location a spherical scan is performed with the pedestal pointing in all combinations of 20 azimuth angles and 7 elevation angles. The angle increment is 18° for both the azimuth and elevation angle, leading to the following angles

$$\begin{aligned}\phi &\in \{0^\circ, 18^\circ, 36^\circ, \dots, 342^\circ\} \\ \theta &\in \{0^\circ, 18^\circ, 36^\circ, \dots, 108^\circ\}\end{aligned}$$

where the elevation angle θ and the azimuth angle ϕ are given in the usual spherical coordinate system with θ measured from the vertical z -axis. The orientation of the coordinate system otherwise depends on the specific measurement location. A full spherical scan takes about 41 minutes.

The setup of the spectrum analyzer was as follows,

Make: Agilent 4440A
 Frequency span: 500 MHz to 3.02 GHz.
 Sampling: 7000 points, corresponding to a resolution bandwidth of 360 kHz.
 Sweep time: 100 ms.



Fig. 3. Measurements in the City area.



Fig. 4. Measurements in the Dwelling area.

No. of sweeps: 10 sweeps are done for each direction of the horn antenna.

Attenuator: 0 dB or 10 dB, depending on location.

The amplifier was inserted to increase the sensitivity and has the following main specifications,

Make: Miteq AMF-2 D-005080-25-13P.
 Frequency range: 0.5–8 GHz.
 Gain: 22 dB.
 1dB comp.: 13 dBm.
 NF: 1.5–2 dB.

The horn antenna is an ETS-Lindgren 3164-03 specified to cover the frequency range of 400 MHz to 6 GHz and with a gain of 3–10 dBi in the frequencies of interest. It is specified to have cross polarization isolation better than 25 dB.

With the purpose of investigating the variation due to the geographical location and type of environment, a small series of measurements were made in the following locations in and near the city of Aalborg, Denmark:

City: In the center of Aalborg (Poul Paghs Gade). See photos in Fig. 3.

Dwell: A residential area typically with single family homes, see photos in Fig. 4.

Rural: A rural area south of Aalborg (near Gultentorp). See photos in Fig. 5.

Gar1: On the university campus (outside the garage of the measurement van). This was the first measurement to be carried out.

Gar2: Similar to the Gar1 measurement, but this measurement was made as the last, several hours later. See photos in Fig. 6.

NoIn: In order to allow estimation of the system noise floor, a special measurement was done without input. This was achieved by replacing the horn antenna outputs with 50Ω terminations during a measurement with pedestal in the university lab.



Fig. 5. Measurements in the Rural area.



Fig. 6. For the ‘Garage’ measurements (Gar1 and Gar2) the car and trailer were placed outside the building with the gray garage doors.

III. MEASUREMENT PROCESSING

The main purpose of the current work is to study background interference with respect to power level and power variation with Rx direction. Since it may be very difficult to separate intended and interfering signals, the measurements for this should ideally be made without the signals from the intended user or system. Without the intended signals, the signals from the possibly unknown sources can be measured more accurately. However, in practice this approach is often not feasible, since it is typically not possible to switch off, e.g., an GSM or LTE network while the measurements take place. Instead, a “silent” or unused band with frequencies near the band of the desired signals or system.

Table I shows the frequency bands considered in this work, with start and stop frequencies listed for each band label. Labels with ‘a’ in them, e.g. LTE800a1, are for potentially actively used bands, while Labels with ‘s’ in them, e.g. LTE800s, are for unused bands.

Define $P_\psi(\theta_k, \phi_l, f_m, r)$ as the spectrum analyzer measurement for the horn antenna direction given by the angle pair (θ_k, ϕ_l) , measured at the frequency f_m , and r is the sweep number, as described in Section II. The polarization is denoted by ψ . For each antenna direction, an average over frequency and repetition is defined as

$$Q_\psi(\theta_k, \phi_l) = \frac{1}{NR} \sum_{r=1}^R \sum_{m \in I} P_\psi(\theta_k, \phi_l, f_m, r) \quad (1)$$

where I is the set of integers m such that $f_{\text{start}} \leq f_m \leq f_{\text{end}}$, and N is the size of this set. The number of repeated sweeps is $R = 10$. Thus, $Q_\psi(\cdot)$ is an estimate of the spherical power distribution, averaged over a given frequency band and in time. Examples of the power distributions are given in Fig. 7–10.

Two basic statistics are derived from the power distributions:

Power Median: Computed from $Q_\psi(\cdot)$ as the median over the different directions defined by all com-

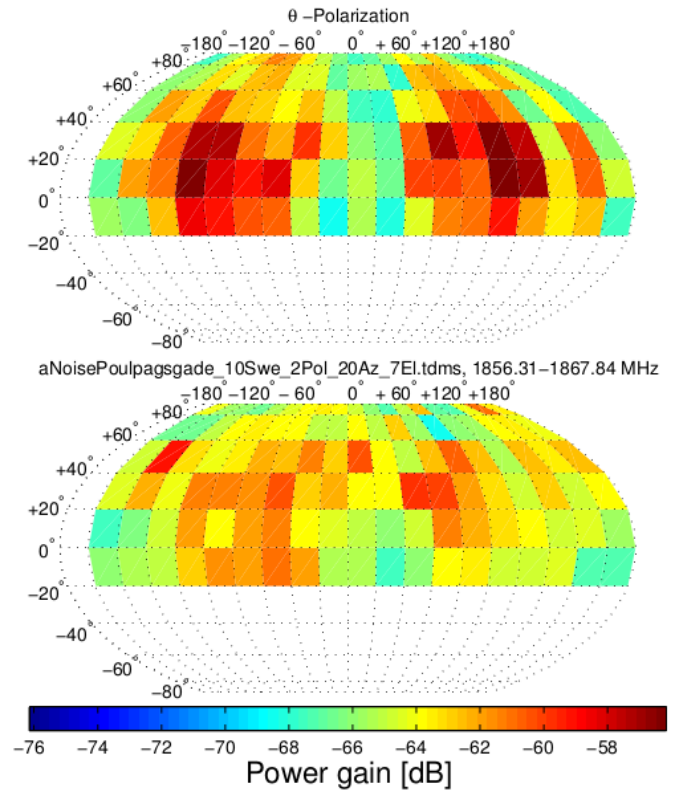

Fig. 7. Estimated power distribution for the GSM1800a2 band for the City measurement location.

TABLE I
OVERVIEW OF FREQUENCY BANDS USED, IN MHZ.

Band Label	Start	Stop	Comment
LTE800a1	832	842	LTE800 TT network
LTE800a2	842	862	LTE800 TDC network
LTE800s	766	774	DVB-T far away (Sjælland)
GSM1800a1	1815	1827	GSM1800 TDC network
GSM1800a2	1856	1868	GSM1800 Telia network
GSM1800s	1644.3	1646.6	INMARSAT-rescue
LTE2500a1	2620	2640	LTE2500 TDC network
LTE2500a2	2650	2670	LTE2500 Telia network
LTE2500s	2255.5	2287.5	HUBBLE/SpaceShuttle
GPS-1	1565	1585	
DVB-T	534	542	About 10 km away, hor. pol.

binations of the measured azimuth and elevation angles.

Power Variation: Computed as

$$\sigma = \chi^{95\%} - \chi^{5\%} \quad (2)$$

where χ^α is the α -level percentile estimated from the power measured in all the directions.

IV. RESULTS

All the power median values are shown in Table II and Table III for the ϕ - and θ -polarizations, respectively. First

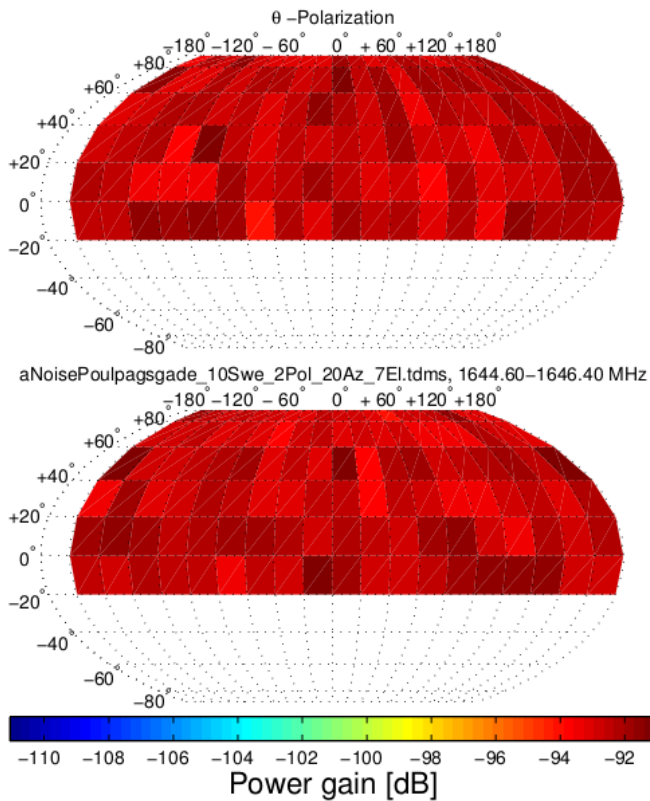

Fig. 8. Estimated power distribution for the GSM1800s band for the City measurement location.

of all the noise floor of the measurements is established, using the measurements where the horn antenna is replaced by terminations (the NoIn measurements). The results for the NoIn measurements are shown as the first column of both tables, where it is clear that the median of $Q_{\psi}(\cdot)$ is around -92.5 dBm for both of the polarizations.

Using a value of -92.0 dBm as threshold, all the values of the remaining columns of the two tables have been colored depending on being above or below the threshold. From this it is noticed that LTE800 signals seems to be present mainly in the City measurements, while sufficient power is received in the GSM1800 bands in all cases. For LTE2500, sufficient power is received in the first operator band ‘a1’ for all locations, even to some extent for the Rural measurements. For the other operator band it is only the City measurements that receive sufficient power.

As a kind of reference, the last two lines of the tables confirm the expectations; it was not expected to receive the weak GPS signals with this setup, while the DVB-T signal is quite strong in all locations. Further, the ϕ -polarization is strongest in all measurements, which is consistent with the horizontal polarization of the Tx.

The measurements for Gar1 and Gar2 are repeated measurements, performed several hours apart. The results for these measurements are less than 0.7 dB apart for the θ -polarization. This also the case for the ϕ -polarization, except for GSM1800a2 and DVB-T where the differences are 1.2 dB and 1.7 dB, respectively.

Unfortunately, the power medians in all of the bands

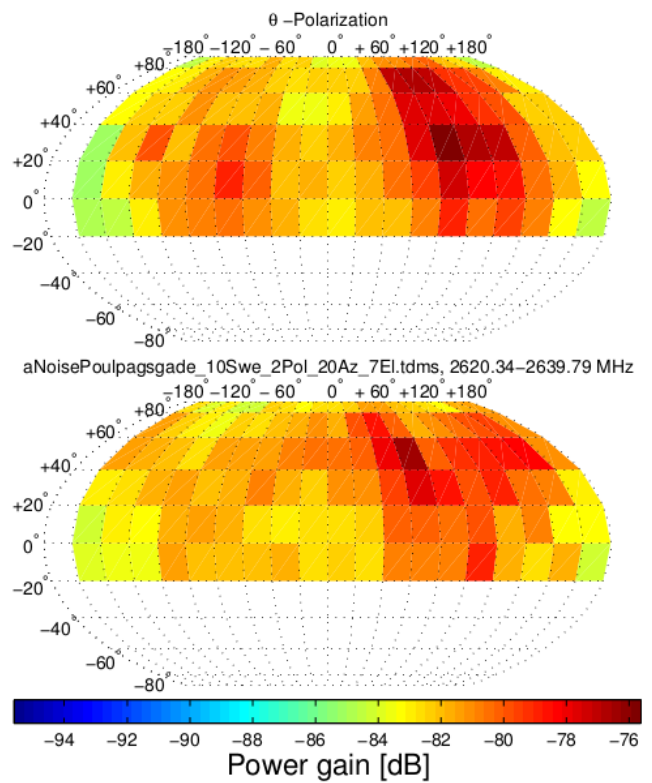

Fig. 9. Estimated power distribution for the LTE2500a1 band for the City measurement location.

selected as “silent” bands, *i.e.*, the LTE800s, GSM1800s, LTE2500s bands, is below the -92 dBm threshold. One exception exists, the LTE800s and City combination which is 0.9 dB above the threshold. Therefore, the received power in these bands are generally very weak and close to the noise floor of the system in the current setup.

Table IV–V shows power variation values, as defined in (2). From the tables it is noticed that for the ‘*s’ bands the power variation is below or equal to 2.0 dB, except for LTE800s in the City and Dwell locations where up to 4.4 dB is obtained. The most likely explanation for the very low power variation is the low input power levels that are close or below to the system noise level. For comparison the power variation for the DVB-T band, were a strong signal is received, is 11.5–16.2 dB.

V. CONCLUSION

The objective of the current work has been to measure the background interference and determine power levels and variations depending on the angle of arrival at the mobile location. Background interference has been defined as signals and noise received within the band of a given cellular system, excluding the signals originating from the system itself.

A small series of initial exploratory measurements were performed with a spectrum analyzer connected to a spherically scanning horn antenna. The measurements were done in different geographical locations, urban, sub-urban, rural.

Power distributions were successfully obtained within frequency bands where various systems are known to transmit. However, the median power levels in bands where only

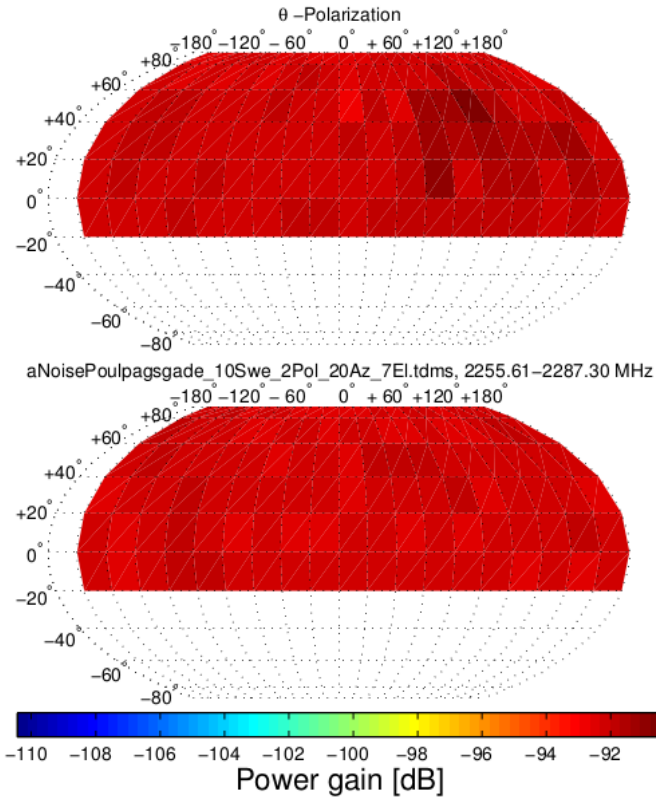

Fig. 10. Estimated power distribution for the LTE2500s band for the City measurement location.

TABLE II

POWER MEDIAN IN THE ϕ -POLARIZATION. THE VALUES ARE IN DBM.

	NoIn	Gar1	Gar2	City	Dwell	Rural
LTE800a1	-92.8	-93.1	-92.5	-89.2	-92.9	-93.0
LTE800a2	-92.3	-92.5	-91.8	-90.6	-92.0	-92.9
LTE800s	-92.8	-92.4	-92.2	-91.1	-92.2	-92.8
GSM1800a1	-92.9	-78.5	-78.7	-77.2	-82.1	-91.0
GSM1800a2	-92.8	-72.2	-71.0	-64.2	-76.5	-86.0
GSM1800s	-92.7	-93.1	-92.9	-92.7	-93.1	-93.1
LTE2500a1	-92.3	-82.0	-81.8	-82.0	-86.0	-91.1
LTE2500a2	-92.0	-92.4	-92.1	-74.2	-92.3	-92.3
LTE2500s	-92.3	-92.8	-92.4	-92.3	-92.8	-92.7
GPS-1	-92.6	-93.1	-92.7	-92.1	-93.1	-93.1
DVB-T	-92.2	-57.2	-55.5	-54.8	-54.3	-54.7

interference is assumed to exist, are generally too close to the system noise floor around -92 dBm median power (measured in a bandwidth of 360 kHz).

The measurements were performed in an overall bandwidth of about 2.5 GHz. This has the advantage of flexibility by allowing the selection of the analyzed frequency band in post processing of the data. However, the disadvantage is that system noise floor is generally larger than if more narrow bands are measured.

To solve the problem of too high noise floor in the analysis, future work will likely involve more measurements where only selected frequency bands are included.

TABLE III

POWER MEDIAN IN THE θ -POLARIZATION. THE VALUES ARE IN DBM.

	NoIn	Gar1	Gar2	City	Dwell	Rural
LTE800a1	-92.8	-92.8	-92.4	-89.2	-92.9	-93.0
LTE800a2	-92.3	-92.0	-91.5	-90.3	-92.2	-92.7
LTE800s	-92.8	-92.7	-92.4	-91.1	-92.6	-92.9
GSM1800a1	-92.9	-78.7	-79.0	-76.7	-82.3	-90.9
GSM1800a2	-92.8	-71.8	-71.1	-63.7	-77.0	-86.0
GSM1800s	-92.7	-93.0	-92.8	-92.6	-93.2	-93.1
LTE2500a1	-92.3	-82.3	-82.3	-82.0	-86.5	-91.3
LTE2500a2	-92.0	-92.5	-92.1	-74.3	-92.3	-92.3
LTE2500s	-92.2	-92.7	-92.4	-92.1	-92.7	-92.7
GPS-1	-92.6	-93.1	-92.7	-92.2	-93.1	-93.0
DVB-T	-92.2	-59.0	-58.6	-56.2	-58.0	-57.5

TABLE IV

POWER VARIATION IN THE ϕ -POLARIZATION, DEFINED AS THE DIFFERENCE BETWEEN THE 5% AND 95% PERCENTILES. THE VALUES ARE IN DBM.

	NoIn	Gar1	Gar2	City	Dwell	Rural
LTE800a1	0.9	2.1	3.0	6.4	3.0	2.8
LTE800a2	0.6	1.5	2.7	3.6	2.6	1.1
LTE800s	0.9	1.9	1.9	3.4	4.4	1.7
GSM1800a1	0.8	5.3	6.6	6.9	7.4	3.5
GSM1800a2	0.7	7.7	9.3	6.7	6.6	6.1
GSM1800s	2.1	2.0	1.9	2.0	1.9	2.0
LTE2500a1	0.6	3.8	5.6	5.2	5.0	3.3
LTE2500a2	0.6	0.6	0.7	6.2	0.6	0.7
LTE2500s	0.5	0.6	0.6	0.6	0.5	0.5
GPS-1	0.7	0.8	0.7	1.5	0.7	0.7
DVB-T	0.9	15.5	15.2	11.5	11.9	16.2

REFERENCES

- [1] R. Verdone and A. Zanella, Eds., *Pervasive Mobile and Ambient Wireless Communications, COST Action 2100*. Springer, 2012, ISBN 978-1-4471-2315-6.
- [2] M. Rumney, R. Pirkl, M. H. Landmann, and D. A. Sanchez-Hernandez, "MIMO over-the-air research, development, and testing," *International Journal of Antennas and Propagation*, 2012.
- [3] W. Fan, X. Carreño, J. Ø. Nielsen, J. Ashta, G. F. Pedersen, and M. Knudsen, "Verification of emulated channels in multi-probe based mimo ota testing setup," in *Proc. 7th European Conference on Antenna and Propagation (EUCAP 2013)*, 2013.
- [4] R4-126229, "3GPP TSG-RAN4 meeting #65: SNR based measurement methods in anechoic chambers," Spirent Communications, Tech. Rep., 2012.

TABLE V
POWER VARIATION IN THE θ -POLARIZATION, DEFINED AS THE
DIFFERENCE BETWEEN THE 5% AND 95% PERCENTILES. THE VALUES
ARE IN DBM.

	NoIn	Gar1	Gar2	City	Dwell	Rural
LTE800a1	0.9	2.1	3.0	6.4	3.0	2.8
LTE800a2	0.6	1.5	2.7	3.6	2.6	1.1
LTE800s	0.9	1.9	1.9	3.4	4.4	1.7
GSM1800a1	0.8	5.3	6.6	6.9	7.4	3.5
GSM1800a2	0.7	7.7	9.3	6.7	6.6	6.1
GSM1800s	2.1	2.0	1.9	2.0	1.9	2.0
LTE2500a1	0.6	3.8	5.6	5.2	5.0	3.3
LTE2500a2	0.6	0.6	0.7	6.2	0.6	0.7
LTE2500s	0.5	0.6	0.6	0.6	0.5	0.5
GPS-1	0.7	0.8	0.7	1.5	0.7	0.7
DVB-T	0.9	15.5	15.2	11.5	11.9	16.2