



Aalborg Universitet

AALBORG UNIVERSITY  
DENMARK

## A New Power Calculation Method for Single-Phase Grid-Connected Systems

Yang, Yongheng; Blaabjerg, Frede

*Published in:*

Proceedings of the 2013 IEEE International Symposium on Industrial Electronics (ISIE)

*DOI (link to publication from Publisher):*

[10.1109/ISIE.2013.6563684](https://doi.org/10.1109/ISIE.2013.6563684)

*Publication date:*

2013

*Document Version*

Early version, also known as pre-print

[Link to publication from Aalborg University](#)

*Citation for published version (APA):*

Yang, Y., & Blaabjerg, F. (2013). A New Power Calculation Method for Single-Phase Grid-Connected Systems. In *Proceedings of the 2013 IEEE International Symposium on Industrial Electronics (ISIE)* (pp. 1-6). IEEE Press. Industrial Electronics (ISIE), IEEE International Symposium on <https://doi.org/10.1109/ISIE.2013.6563684>

### General rights

Copyright and moral rights for the publications made accessible in the public portal are retained by the authors and/or other copyright owners and it is a condition of accessing publications that users recognise and abide by the legal requirements associated with these rights.

- ? Users may download and print one copy of any publication from the public portal for the purpose of private study or research.
- ? You may not further distribute the material or use it for any profit-making activity or commercial gain
- ? You may freely distribute the URL identifying the publication in the public portal ?

### Take down policy

If you believe that this document breaches copyright please contact us at [vbn@aub.aau.dk](mailto:vbn@aub.aau.dk) providing details, and we will remove access to the work immediately and investigate your claim.



## A New Power Calculation Method for Single-Phase Grid-Connected Systems

Yang, Yongheng; Blaabjerg, Frede

*Published in:*

Proc. IEEE ISIE 2013

*DOI (link to publication from Publisher):*

[10.1109/ISIE.2013.6563684](https://doi.org/10.1109/ISIE.2013.6563684)

*Publication date:*

2013

[Link to publication from Aalborg University - VBN](#)

*Suggested citation format:*

Y. Yang and F. Blaabjerg, "A New Power Calculation Method for Single-Phase Grid-Connected Systems," in *Proc. of IEEE ISIE*, pp. 1-6, 28-31 May 2013.

### **General rights**

Copyright and moral rights for the publications made accessible in the public portal are retained by the authors and/or other copyright owners and it is a condition of accessing publications that users recognize and abide by the legal requirements associated with these rights.

- Users may download and print one copy of any publication from the public portal for the purpose of private study or research.
- You may not further distribute the material or use it for any profit-making activity or commercial gain.
- You may freely distribute the URL identifying the publication in the public portal.

### **Take down policy**

If you believe that this document breaches copyright please contact us at [ybn@aub.aau.dk](mailto:ybn@aub.aau.dk) providing details, and we will remove access to the work immediately and investigate your claim.

# A New Power Calculation Method for Single-Phase Grid-Connected Systems

Yongheng Yang, Frede Blaabjerg

Department of Energy Technology  
Aalborg University

Pontoppidanstraede 101, Aalborg East, DK-9220, Denmark

[yoy@et.aau.dk](mailto:yoy@et.aau.dk), [fbl@et.aau.dk](mailto:fbl@et.aau.dk)

**Abstract**— A new method to calculate average active power and reactive power for single-phase systems is proposed in this paper. It can be used in different applications where the output active power and reactive power need to be calculated accurately and fast. For example, a grid-connected photovoltaic system in low voltage ride through operation mode requires a power feedback for the power control loop. Commonly, a Discrete Fourier Transform (DFT) based power calculation method can be adopted in such systems. However, the DFT method introduces at least a one-cycle time delay. The new power calculation method, which is based on the adaptive filtering technique, can achieve a faster response. The performance of the proposed method is verified by experiments and demonstrated in a 1 kW single-phase grid-connected system operating under different conditions. Experimental results show the effectiveness of the proposed power calculation method.

**Keywords**— *instantaneous power; active power; reactive power; single-phase system; photovoltaics; adaptive filtering*

## I. INTRODUCTION

Recent data shows that the development of single-phase photovoltaic systems connected to the grid is booming [1], [2]. The high penetration of single-phase renewable energy systems also introduces challenges to the control of the single-phase grid-connected systems. Thus, new grid codes are expected to be put up to regulate the interconnection of renewable energy systems and the grid [3]-[6]. In these grid codes, the grid-connected systems are required to be equipped with Low Voltage Ride-Through (LVRT) capability and to inject reactive power in the case of grid voltage faults. Therefore, the control systems should be redesigned and ready for such applications in the future.

Traditional control schemes for single-phase systems include two cascaded loops – the inner current loop and the outer voltage loop, and normally the single-phase grid-connected systems are operating at unity power factor [5]-[9]. In that case, there is no need to calculate the average active power and the reactive power. In respect to control the single-phase systems under grid faults, possible solutions are based on single-phase  $PQ$  theory [5], [6], [10], [11], droop-control methods [12]-[14] and the instantaneous power control method as discussed in [15]. Therefore, it is necessary to calculate the average active power and reactive power fast and accurately in order to enhance the LVRT capability for single-phase systems.

It should be pointed out that the power calculation is necessary not only in single-phase systems controlled by the single-phase  $PQ$  theory but also e.g. in the droop-controlled micro-grid [16].

A simple way to get the instantaneous power of single-phase systems is to multiply the measured grid voltage and grid current. However, the instantaneous power will present a variation at twice the grid fundamental frequency. By applying a well-designed filter after the multiplication, the average active power and the reactive power can be obtained [16], but the transient response is slow because of the filter delay. Another solution is based on the Discrete Fourier Transform (DFT). However, the main drawback of this method is that it introduces a period delay of the grid fundamental voltage.

One possibility to calculate the average active and reactive power is based on the three-phase instantaneous power theory [10], [11]. In three-phase systems, the instantaneous active power and reactive power can be obtained easily with the help of the Clark Transform and the Park Transform. Thus, inspired by this concept, the “ $\alpha\beta$ ” system can be built up by a phase shift of  $\pi/2$  rad in respect to the fundamental period of the input voltage or current. Followed by the Park Transform ( $\alpha\beta \rightarrow dq$ ), the average active power and the reactive power can be calculated. Hence, the mission of the power calculation is shifted to create an Orthogonal Signal Generator (OSG) system, such as the Hilbert Transform based OSG, the inverse Park Transform based OSG and the second order generalized integrator based OSG [11], [17]. Those methods based on the OSG structure are more useful for single-phase applications since a grid synchronization unit is normally required. However, the transient responses of such methods are dependent on the performances of the OSG systems.

Inspired by the Enhanced PLL proposed in [21], a novel average power calculation method is proposed in this paper. An overview of the possible power calculation methods for single-phase systems is firstly presented, followed by the description of the proposed method and a comparison of the power calculation methods by simulations and experiments. Finally, the proposed method is tested in a 1 kW single-phase system in low voltage ride-through operation mode. The experimental results show the effectiveness of the proposed method in the calculation of the average active and reactive power. It can also be used in other applications which require a fast and accurate average power calculation.

## II. OVERVIEW OF POWER CALCULATION METHODS

Fig. 1 shows the overall control structure of a single-phase grid-connected system based on the single-phase  $PQ$  theory [5], [6], [11]. The power calculation unit is highlighted in Fig. 1. The control system for this application also requires an OSG structure to generate orthogonal voltage signals ( $v_{g\alpha}$  and  $v_{g\beta}$  which are shown in Fig. 1). Thus the transient performance of the control system (power control loop) depends on the response of the power calculation unit.

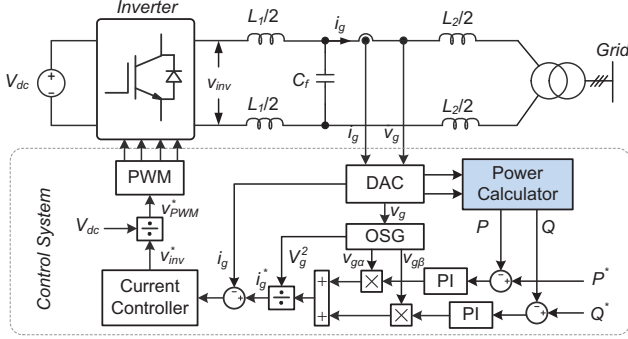

Fig. 1. Overall control structure of a single-phase grid-connected system based on the single-phase  $PQ$  theory.

The injected grid current by a single-phase inverter is normally required to be synchronized with the grid voltage. Let the grid voltage and current be  $v_g(t) = V_g \cos(\omega t)$  and  $i_g(t) = I_g \cos(\omega t - \varphi)$ , and thus the instantaneous power of the single phase system can be calculated as,

$$p_{ins}(t) = v_g(t) i_g(t) = p(t) + q(t), \quad (1)$$

where  $p(t)$  and  $q(t)$  are the instantaneous active power and the instantaneous reactive power of the single-phase system and they can be expressed as,

$$\begin{cases} p(t) = \frac{1}{2} V_g I_g \cos(\varphi) [1 + \cos(2\omega t)] \\ q(t) = \frac{1}{2} V_g I_g \sin(\varphi) \sin(2\omega t) \end{cases}, \quad (2)$$

in which  $\omega$  is the grid fundamental frequency in  $rad/s$ ,  $\varphi$  is the power angle in  $rad$  and  $V_g$ ,  $I_g$  are the amplitude of the grid voltage and the grid current respectively.

### A. Power Calculation based on Low-Pass Filter

By applying a Low-Pass Filter (LPF) to the instantaneous power  $p_{ins}(t)$ , the average active power  $P$  can be obtained. Similarly, by introducing a quarter period-delay of the fundamental voltage ( $v'_g(t) = V_g \sin(\omega t)$ , which is the in-quadrature signal of the original voltage), the instantaneous power  $p'_{ins}(t)$  can be calculated as,

$$p'_{ins}(t) = v'_g(t) i_g(t) = p'(t) + q'(t), \quad (3)$$

where,

$$\begin{cases} p'(t) = \frac{1}{2} V_g I_g \cos(\varphi) \sin(2\omega t) \\ q'(t) = \frac{1}{2} V_g I_g \sin(\varphi) [1 - \cos(2\omega t)] \end{cases}. \quad (4)$$

Hence, the average reactive power  $Q$  can also be obtained by filtering the instantaneous power  $p'_{ins}(t)$  using a LPF. It can be seen in (2) and (4) that the instantaneous power is oscillating at twice the fundamental grid frequency, which means that the cut-off frequency of LPFs must be very low [12]. The structure of the power calculation method based on low-pass filters is shown in Fig. 2.

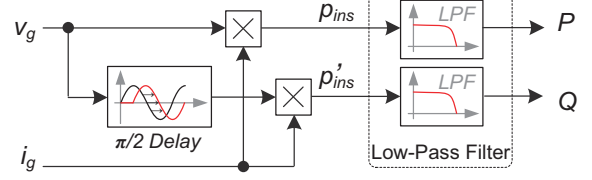

Fig. 2. Power calculation by filtering the instantaneous power using low-pass filters for single-phase systems.

### B. Discrete Fourier Transform based Power Calculation

The Discrete Fourier Transform (DFT) can be employed for the average power calculation. The Fourier series of the input signal can be expressed as,

$$f(t) = \frac{a_0}{2} + \sum_{n=1}^{\infty} [a_n \cos(n\omega t) + b_n \sin(n\omega t)], \quad (5)$$

in which  $n$  represents the order of the harmonics ( $n = 1$  corresponds to the fundamental component). Thus, the magnitude and phase of the fundamental components of the input grid voltage and grid current can be calculated by the following equations:

$$|H_1| = \sqrt{a_1^2 + b_1^2}, \quad \angle H_1 = \tan^{-1} \left( \frac{a_1}{b_1} \right), \quad (6)$$

where  $a_1 = \frac{\omega}{\pi} \int_{-T}^T f(t) \cos(\omega t) dt$ ,  $b_1 = \frac{\omega}{\pi} \int_{-T}^T f(t) \sin(\omega t) dt$ ,

and  $\omega$  is the grid fundamental frequency in  $rad/s$ ,  $T$  is the grid fundamental period and  $f(t)$  is the input signal.

Thus, the average active power  $P$  and reactive power  $Q$  can be expressed as,

$$\begin{cases} P = \frac{1}{2} |v_g| |i_g| \cos(\angle v_g - \angle i_g), \\ Q = \frac{1}{2} |v_g| |i_g| \sin(\angle v_g - \angle i_g). \end{cases} \quad (7)$$

in which the harmonic components are neglected. Based on (7), the power calculation method based on DFT can be structured as it is shown in Fig. 3.

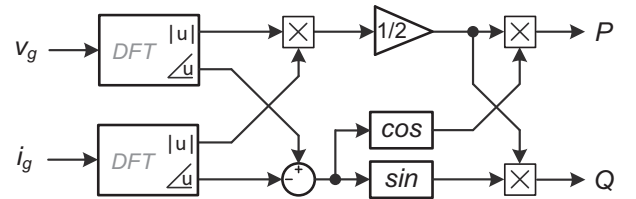

Fig. 3. Power calculation based on discrete Fourier transform for single-phase grid-connected systems.

Since the DFT unit uses a running average window, it will take one cycle of the fundamental signal to output the correct amplitude and phase of the input signal. Thus, this power calculation method will introduce one cycle delay with respect to the fundamental signal.

### C. Power Calculation based on Orthogonal Signal Generator

Another power calculation method is based on the Orthogonal Signal Generator (OSG). Similar to the three-phase instantaneous power theory [10], the active power  $P$  and reactive power  $Q$  for a single-phase application can be computed with the help of OSG systems:

$$\begin{cases} P = \frac{1}{2}(v_{g\alpha}i_{g\alpha} + v_{g\beta}i_{g\beta}) \\ Q = \frac{1}{2}(v_{g\beta}i_{g\alpha} - v_{g\alpha}i_{g\beta}) \end{cases}, \quad (8)$$

in which the subscripts “ $g\alpha$ ” and “ $g\beta$ ” denote the “ $\alpha$ ” and “ $\beta$ ” components of the grid voltage/current in a  $\alpha\beta$ -stationary reference frame. The structure of this power calculation method is shown in Fig. 4.

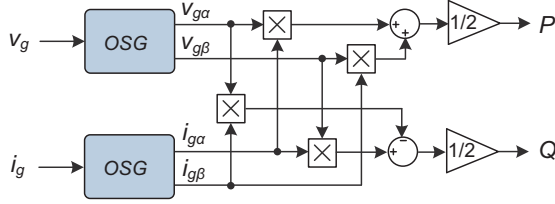

Fig. 4. Power calculation based on orthogonal signal generator for single-phase systems.

As it is highlighted in Fig. 4, the main task of this power calculation method is to create an effective OSG system which has less computation burden with a fast and accurate response in such a way to enhance the performance of this method. The easiest way to build up an OSG system is to use a delay unit which introduces a  $90^\circ$  phase shift corresponding to the fundamental component of the input signal as it is used in Fig. 2.

Other methods like Hilbert transform, inverse Park transform and the Second Order Generalized Integrator (SOGI) can be used to create OSG system [8], [11], [16]. In this paper, the SOGI based OSG system is used since it is an adaptive filtering system and behaves as a generalized integrator.

### III. PROPOSED POWER CALCULATION METHOD

This power calculation method is inspired by the Enhanced PLL and adaptive filtering techniques [15], [21], [23]. Rewrite the instantaneous power of the single-phase system as,

$$\begin{aligned} p_{ins}(t) &= v_g(t)i_g(t) \\ &= \frac{1}{2}V_g I_g \cos(\varphi)[1 + \cos(2\omega t)] + \frac{1}{2}V_g I_g \sin(\varphi)\sin(2\omega t) \\ &= \underbrace{P[1 + \cos(2\omega t)]}_{p(t)} + \underbrace{Q\sin(2\omega t)}_{q(t)} \end{aligned} \quad (9)$$

in which  $\omega$  is the grid frequency in  $rad/s$  and  $P$ ,  $Q$  are the active power and reactive power of the system. As it is shown

in (9), the instantaneous power for a single-phase system can be divided into two parts, namely, the instantaneous active power part  $p(t)$  and the instantaneous reactive power part  $q(t)$ .

Define the desired/reference instantaneous power as,

$$\hat{p}_{ins}(t) = \hat{p}(t) + \hat{q}(t) = \hat{P}[1 + \cos(2\hat{\omega}t)] + \hat{Q}\sin(2\hat{\omega}t), \quad (10)$$

where  $\hat{\omega}$  is the estimated grid frequency from the Phase Locked Loop (PLL) system. Then, a cost function can be defined as,

$$\begin{aligned} E(\hat{P}, \hat{Q}) &= \frac{1}{2}\|e\|^2 = \frac{1}{2}\|p_{ins}(t) - \hat{p}_{ins}(t)\|^2 \\ &= \frac{1}{2}[p(t) - \hat{p}(t)]^2 + \frac{1}{2}[q(t) - \hat{q}(t)]^2. \end{aligned} \quad (11)$$

By using Least-Mean-Square (LMS) adaptive algorithm to minimize the cost function [23], then the following differential equations are obtained,

$$\dot{\hat{P}} = -\mu_1 \frac{\partial E(\hat{P}, \hat{Q})}{\partial \hat{P}} = \mu_1 e_p [1 + \cos(2\hat{\omega}t)], \quad (12)$$

$$\dot{\hat{Q}} = -\mu_2 \frac{\partial E(\hat{P}, \hat{Q})}{\partial \hat{Q}} = \mu_2 e_q \sin(2\hat{\omega}t), \quad (13)$$

in which  $\mu_1$  and  $\mu_2$  are the active and reactive power control parameters,  $e_p = p(t) - \hat{p}(t)$ ,  $e_q = q(t) - \hat{q}(t)$ , and  $\hat{P}$ ,  $\hat{Q}$  are the calculated/estimated active power and reactive power of a single-phase system. Equation (12) can be expanded as,

$$\begin{aligned} \dot{\hat{P}} &= \mu_1 [P(1 + \cos(2\omega t)) - \hat{P}(1 + \cos(2\hat{\omega}t))](1 + \cos(2\hat{\omega}t)) \\ &= \mu_1 [(P - \hat{P}) + P\cos(2\omega t) - \hat{P}\cos(2\hat{\omega}t)] \\ &\quad + \mu_1 [(P - \hat{P})\cos(2\hat{\omega}t) + P\cos(2\omega t)\cos(2\hat{\omega}t) - \hat{P}\cos^2(2\hat{\omega}t)]. \end{aligned} \quad (14)$$

If the PLL system can offer an accurate estimation of the grid frequency  $\hat{\omega} \approx \omega$ , and  $P - \hat{P} \approx 0$  in steady state, equation (14) can approximately be given as,

$$\begin{aligned} \dot{\hat{P}} &\approx \mu_1 (P - \hat{P}) + \frac{\mu_1}{2} [P + P\cos(4\hat{\omega}t) - \hat{P} - \hat{P}\cos(4\hat{\omega}t)] \\ &\approx \frac{3\mu_1}{2} (P - \hat{P}). \end{aligned} \quad (15)$$

Here, the high-frequency terms ( $4\hat{\omega}t$ ) are mitigated by the integrator during the transient period [22]. Similar linearization can be done for equation (13),

$$\dot{\hat{Q}} \approx \frac{\mu_2}{2} (Q - \hat{Q}). \quad (16)$$

Thus, according to (15) and (16), the following transfer functions are valid [22],

$$\begin{cases} \frac{\hat{P}(s)}{P(s)} = \frac{1.5\mu_1}{s + 1.5\mu_1} = \frac{1}{\tau_1 s + 1} \\ \frac{\hat{Q}(s)}{Q(s)} = \frac{0.5\mu_2}{s + 0.5\mu_2} = \frac{1}{\tau_2 s + 1} \end{cases}, \quad (17)$$

where  $\tau_1$ ,  $\tau_2$  are the time constants. Equation (17) indicates that the estimated average power ( $P$  and  $Q$ ) is controlled by  $\mu_1$  and  $\mu_2$  respectively. A large value of  $\mu_{1,2}$  will make the estimated active power or reactive power coming to steady-state quickly, but it will have a high overshoot if it is too large. The settling time can approximately be calculated as:  $4\tau_{1,2}$ , which can be the guidelines for tuning the parameters  $\mu_1$  and  $\mu_2$ . In this paper, the settling-times of the active power and the reactive power are set to be  $5\text{ ms}$ , which means  $\mu_2 = 3\mu_1 = 400$ .

Thus, the continuous implementation of the proposed active and reactive power calculation method can be given as it is shown in Fig. 5. A Phase Locked Loop (PLL) is necessary to synchronize with the grid voltage. It can be predicted that once the synchronization unit can provide a fast and accurate tracking of the grid voltage, the performance of the proposed average power calculation method will be ensured.

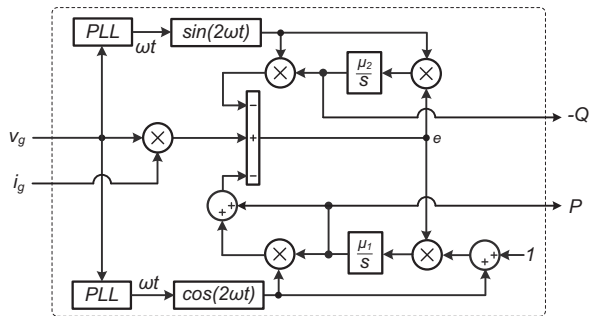

Fig. 5. Proposed active and reactive power calculation method for single-phase systems: grid voltage:  $v_g = V_g \cos(\omega t)$ , grid current:  $i_g = I_g \cos(\omega t + \varphi)$ .

#### IV. SIMULATION AND EXPERIMENTAL RESULTS

In order to verify the effectiveness of the proposed method, a single-phase grid-connected system is built up in MATLAB and tested experimentally. The setup of the entire system is shown in Fig. 6. The parameters of the system are listed in TABLE I.

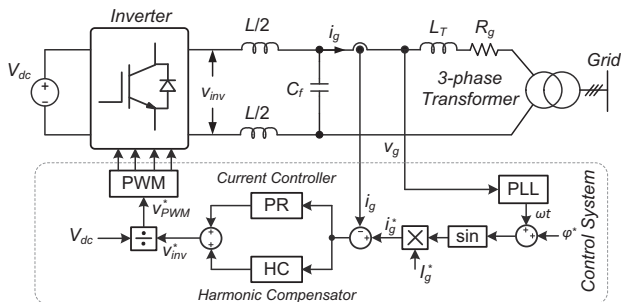

Fig. 6. Simulation and experimental setup of a single-phase grid-connected system with proportional resonant current controller.

The experimental setup consists of two Delta DC sources connected in series, forming the nominal DC voltage  $V_{dc} = 400\text{ V}$  and a three-phase  $5\text{ kW}$  inverter, which is configured as a single-phase system. Instead of an  $LCL$ -filter, an  $LC$ -filter is used in this setup and it is connected to the grid through a three-phase transformer which has a leakage inductance of  $L_T = 4\text{ mH}$ . A Proportional Resonant (PR) controller with Harmonic Compensators (HC) (the 3<sup>rd</sup>, 5<sup>th</sup> and 7<sup>th</sup> harmonics are compensated) is employed in this system as shown in Fig. 6. The proportional and resonant gains for the PR controller are

TABLE I  
SIMULATION AND EXPERIMENTAL PARAMETERS

Grid Voltage Amplitude	$V_N = 230\text{ V}$
Grid Frequency	$\omega = 2\pi \times 50\text{ rad/s}$
LC Filter	$L = 3.6\text{ mH}, C_f = 2.35\text{ }\mu\text{F}$
Transformer Leakage Inductance and Resistance	$L_T = 4\text{ mH}, R_g = 0.02\text{ }\Omega$
Sampling and Switching Frequency	$f_s = f_{sw} = 10\text{ kHz}$
Parameters for the Proposed Method	$\mu_2 = 3\mu_1 = 400$

$K_p = 25$  and  $K_i = 2000$ , respectively; while the control gains for harmonic compensators are  $K_{i3,5,7} = 3000$ . The control system is implemented in a dSPACE DS 1103 system.

In the simulation, the reference current changed from  $i_g^*(t) = 5\cos(\omega t)\text{ A}$  to  $i_g^*(t) = 2\cos(\omega t - \pi/3)\text{ A}$  at  $t = 0.713\text{ s}$  and it went back to the normal condition at  $t = 0.875\text{ s}$ . For comparison, in the experiment, the amplitude of the grid current  $I_g$  is set to be  $5\text{ A}$  in unity power factor operation; while the system is shifted to non-unity power factor operation with  $I_g = 2\text{ A}$  and  $\varphi = 60^\circ$ . The test results are shown in Fig. 7 and Fig. 8.

As it is shown in Fig. 7 and Fig. 8, when there is a step change for the active power or the reactive power, the power calculation method based on low pass filters takes longer time to come into steady-state compared to other methods. The proposed method and the SOGI-OSG based power calculator can track the power change quickly. Moreover, it is proved that the DFT based method needs at least one cycle delay to calculate the average power as it is analyzed previously. Seen from Fig. 7 (c) and Fig. 8 (b), the proposed method presents a large overshoot in the calculated average reactive power, because the control parameter is set to be  $\mu_2 = 3\mu_1 = 400$ , leading to a  $5\text{ ms}$  settling-time.

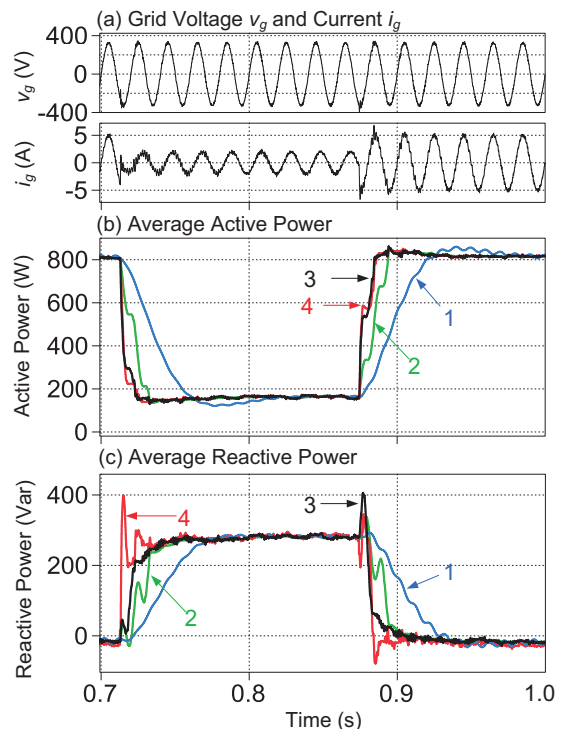
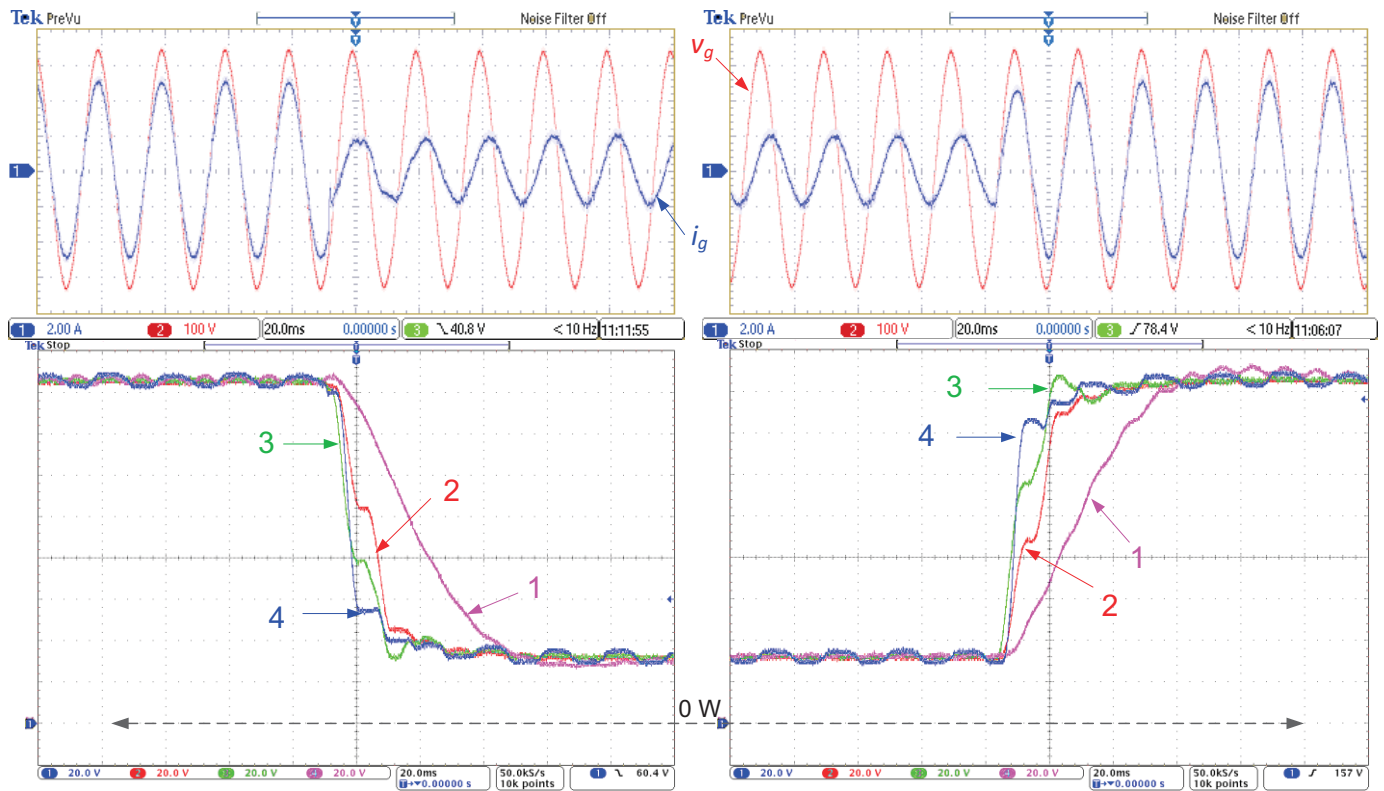
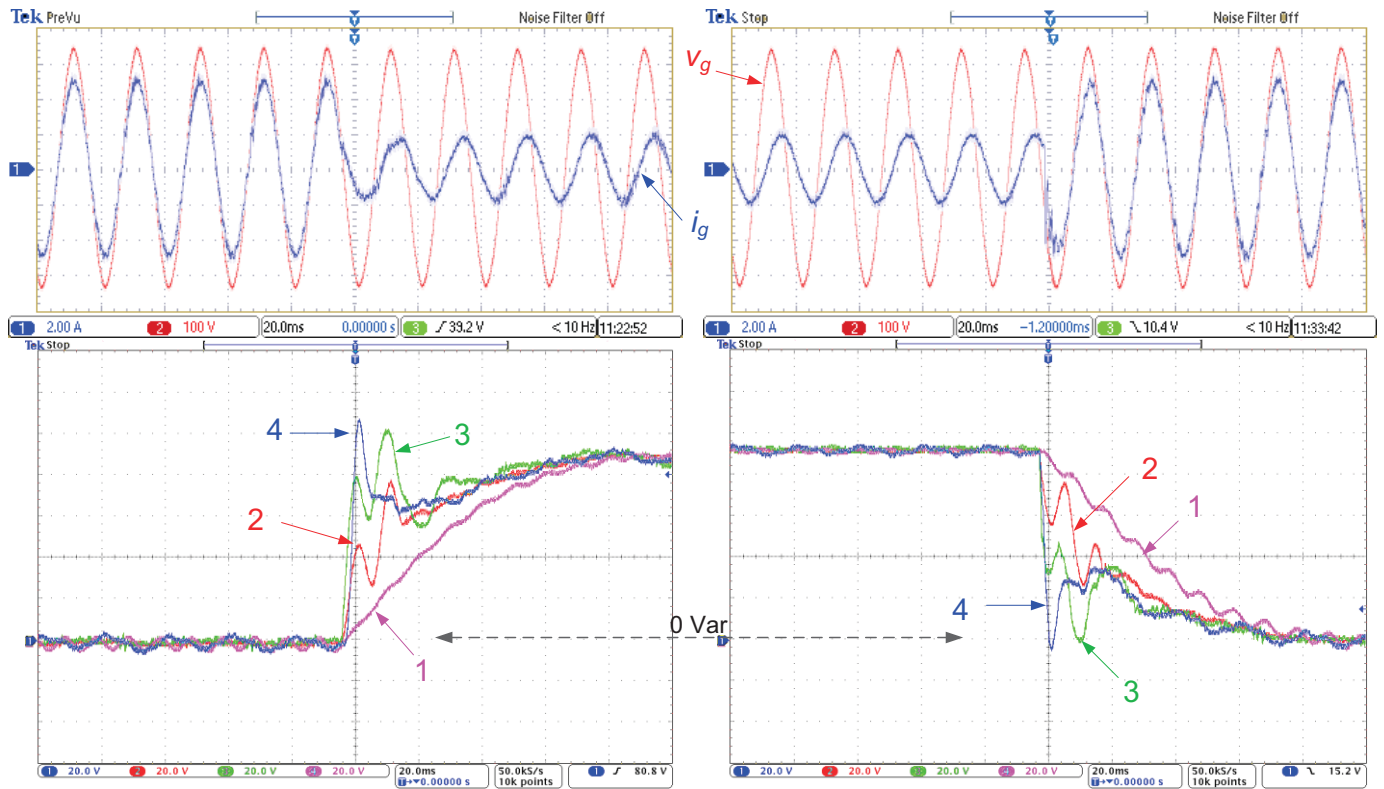

Fig. 7. Simulation results of a single-phase grid-connected system: 1. power calculation based on LPF; 2. power calculation based on DFT; 3. SOGI based power calculator; 4. the proposed method.



(a) average active power [100 W/div]



(b) average reactive power [100 Var/div]

Fig. 8. Measured average active and reactive power for a single-phase grid-connected system using different power calculation methods (Grid voltage  $v_g$ : 100 V/div; Grid current  $i_g$ : 2 A/div; Time: 20 ms/div):

1. power calculation based on LPF; 2. power calculation based on DFT; 3. SOGI based power calculator; 4. the proposed method.

To verify the proposed method, referring to Fig. 1, a 1 kW single-phase grid-connected system is tested in low voltage ride through operation mode based on the single-phase  $PQ$  theory. The average active power and the average reactive power are calculated using the proposed method. A SOGI-OSG based PLL is adopted to synchronize with the grid voltage. The experimental results are shown in Fig. 9. During low voltage ride-through operation, the system injected reactive power and limited active power output in order to prevent the inverter from over-current shutdown. As it is shown in Fig. 9, the proposed method can calculate the average power quickly and effectively. It can also be used in other applications, such as droop-controlled systems.

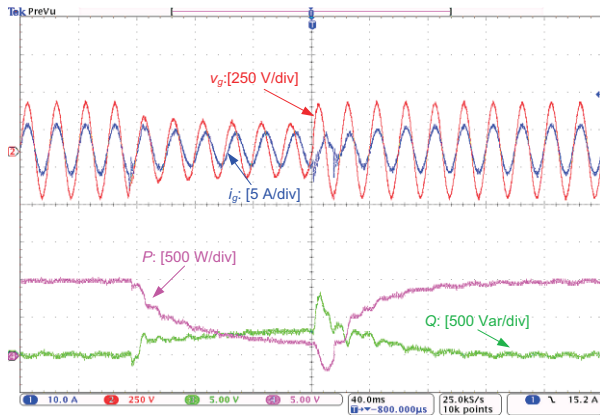

Fig. 9. Experimental results of a single-phase system in low voltage ride through operation (0.45 p.u. voltage sag) using the proposed power calculation method and SOGI-OSG based PLL [ $t$ : 40 ms/div].

## V. CONCLUSIONS

A new power calculation method is proposed in this paper for single-phase applications. It is compared with traditional average power calculation methods in simulations and by experiments. The results demonstrate that the proposed method can calculate the active and reactive power faster than the traditional method - power calculations based on low pass filters and Discrete Fourier Transform. The proposed method is also demonstrated in a 1 kW single-phase grid-connected PV system in low voltage ride through operation. The experimental results show the effectiveness of the proposed power calculation method. This proposed method can be adopted in other single-phase applications, where the average active power and the reactive power are required.

## REFERENCES

- [1] EPIA, "EPIA- Photovoltaic Market Report, 2011," [Online]. Available: <http://www.epia.org/>, 2012.
- [2] M. Braun, T. Stetz, R. Brundlinger, C. Mayr, K. Ogimoto, H. Hatta, H. Kobayashi, B. Kroposki, B. Mather, M. Coddington, K. Lynn, G. Graditi, A. Woyte, and I. MacGill, "Is the distribution grid ready to accept large-scale photovoltaic deployment? State of the art, progress, and future prospects," *Progress in Photovoltaics: Research and Applications*, vol. 20, no. 6, pp. 681-697, 2012.
- [3] Comitato Elettrotecnico Italiano, "CEI 0-21: Reference technical rules for connecting users to the active and passive LV distribution companies of electricity," [Online]. Available: <http://www.ceiweb.it/>.
- [4] H. Kobayashi, "Fault ride through requirements and measures of distributed PV systems in Japan," in *Proc. of IEEE-PES General Meeting*, pp. 1-6, 22-26 July 2012.

- [5] Y. Yang, F. Blaabjerg, and Z. Zou, "Benchmarking of grid fault modes in single-phase grid-connected photovoltaic systems," in *Proc. of ECCE'12*, pp. 4370-4377, 15-20 Sept. 2012.
- [6] Y. Yang and F. Blaabjerg, "Low-voltage ride-through capability of a single-stage single-phase photovoltaic system connected to the low-voltage grid," *International Journal of Photoenergy*, vol. 2013, 2013.
- [7] F. Blaabjerg, R. Teodorescu, M. Liserre, and A.V. Timbus, "Overview of control and grid synchronization for distributed power generation systems," *IEEE Trans. Ind. Electron.*, vol. 53, no. 5, pp. 1398-1409, Oct. 2006.
- [8] R. Teodorescu, M. Liserre, and P. Rodriguez, *Grid Converters for Photovoltaic and Wind Power Systems*, John Wiley & Sons, 2011.
- [9] M. Ciobotaru, R. Teodorescu, F. Blaabjerg, "Control of single-stage single-phase PV inverter," in *Proc. of EPE'05*, pp. P.1-P.10, 2005.
- [10] H. Akagi, E. H. Watanabe, and M. Aredes, *Instantaneous Power Theory and Applications to Power Conditioning*, Wiley-IEEE Press, 2007.
- [11] M. Saitou and T. Shimizu, "Generalized theory of instantaneous active and reactive powers in single-phase circuits based on hilbert transform," in *Proc. of PESC'02*, vol. 3, pp. 1419-1424, 2002.
- [12] G.M.S. Azevedo, M.C. Cavalcanti, F. Bradaschia, F.A.S. Neves, J. Rocabert, and P. Rodriguez, "Enhanced power calculator for droop control in single-phase systems," in *Proc. of ECCE'11*, pp. 391-396, 17-22 Sept. 2011.
- [13] J.C. Vasquez, R.A. Mastromauro, J.M. Guerrero, and M. Liserre, "Voltage support provided by a droop-controlled multifunctional inverter," *IEEE Trans. Ind. Electron.*, vol. 56, no. 11, pp. 4510-4519, Nov. 2009.
- [14] H.J. Avelar, W.A. Parreira, J.B. Vieira, L.C.G. de Freitas, and E.A.A. Coelho, "A state equation model of a single-phase grid-connected inverter using a droop control scheme with extra phase shift control action," *IEEE Trans. Ind. Electron.*, vol. 59, no. 3, pp. 1527-1537, Mar. 2012.
- [15] S.A. Khajehodini, M. Karimi-Ghartemani, A. Bakhshai, and P. Jain, "A power control method with simple structure and fast dynamic response for single-phase grid-connected DG systems," *IEEE Trans. Power Electron.*, vol. 28, no. 1, pp. 221-233, Jan. 2013.
- [16] E.T. Andrade, P.E.M.J. Ribeiro, J.O.P. Pinto, C.L. Chen, J.S. Lai, and N. Kees, "A novel power calculation method for droop-control microgrid systems," in *Proc. of APEC'12*, pp. 2254-2258, 5-9 Feb. 2012.
- [17] M. Ciobotaru, R. Teodorescu, and F. Blaabjerg, "A new single-phase PLL structure based on second order generalized integrator," in *Proc. of PESC'06*, pp. 1-6, June 2006.
- [18] W. Yu, D. Xu, and K. Ma, "A novel accurate active and reactive power calculation method for paralleled UPS system," in *Proc. of APEC'09*, pp. 1269-1275, 15-19 Feb. 2009.
- [19] M. Gao, S. Yang, C. Jin, Z. Ren, M. Chen, and Z. Qian, "Analysis and experimental validation for power calculation based on p-q theory in single-phase wireless-parallel inverters," in *Proc. of APEC'11*, pp. 620-624, 6-11 Mar. 2011.
- [20] S. Golestan, M. Monfared, F.D. Freijedo, and J.M. Guerrero, "Design and tuning of a modified power-based PLL for single-phase grid-connected power conditioning systems," *IEEE Trans. Power Electron.*, vol. 27, no. 8, pp. 3639-3650, 2012.
- [21] M. Karimi-Ghartemani and M.R. Iravani, "A method for synchronization of power electronic converters in polluted and variable-frequency environments," *IEEE Trans. Power Sys.*, vol. 19, no. 3, pp. 1263-1270, Aug. 2004.
- [22] M. Karimi-Ghartemani, M. Mojiri, A. Safaee, J.A. Walseth, S.A. Khajehodini, P. Jain, and A. Bakhshai, "A new phase-locked loop system for three-phase applications," *IEEE Trans. Power Electron.*, vol. 28, no. 3, pp. 1208-1218, Mar. 2013.
- [23] S.C. Douglas, and T.H.-Y. Meng, "A nonlinear error adaptive notch filter for separating two sinusoidal signals," in *Proc. of ACSSC'91*, pp. 673-677 vol. 2, 4-6 Nov. 1991.
- [24] T. Tanaka, E. Hiraki, N. Ishikura, Y. Omura, and M. Yamamoto, "A novel real-time detection method of active and reactive currents for single-phase active power filters," in *Proc. of PESC'07*, pp. 2933-2938, 17-21 June 2007.