



Aalborg Universitet

AALBORG UNIVERSITY  
DENMARK

## Transient Stability Assessment of Power System with Large Amount of Wind Power Penetration

*The Danish Case Study*

Liu, Leo; Chen, Zhe; Bak, Claus Leth; Liu, Zhou; Lund, Per ; Rønne-Hansen, Peter

*Published in:*

Proceedings of the 10th International Power and Energy Conference, IPEC 2012

*DOI (link to publication from Publisher):*

[10.1109/ASSCC.2012.6523312](https://doi.org/10.1109/ASSCC.2012.6523312)

*Publication date:*

2012

*Document Version*

Early version, also known as pre-print

[Link to publication from Aalborg University](#)

*Citation for published version (APA):*

Liu, L., Chen, Z., Bak, C. L., Liu, Z., Lund, P., & Rønne-Hansen, P. (2012). Transient Stability Assessment of Power System with Large Amount of Wind Power Penetration: The Danish Case Study. In *Proceedings of the 10th International Power and Energy Conference, IPEC 2012* (pp. 461-467 ). IEEE.

<https://doi.org/10.1109/ASSCC.2012.6523312>

### General rights

Copyright and moral rights for the publications made accessible in the public portal are retained by the authors and/or other copyright owners and it is a condition of accessing publications that users recognise and abide by the legal requirements associated with these rights.

- ? Users may download and print one copy of any publication from the public portal for the purpose of private study or research.
- ? You may not further distribute the material or use it for any profit-making activity or commercial gain
- ? You may freely distribute the URL identifying the publication in the public portal ?

### Take down policy

If you believe that this document breaches copyright please contact us at [vbn@aub.aau.dk](mailto:vbn@aub.aau.dk) providing details, and we will remove access to the work immediately and investigate your claim.

# Transient Stability Assessment of Power System with Large Amount of Wind Power Penetration: the Danish Case Study

Chengxi Liu, Zhe Chen, Claus Leth Bak, Zhou Liu

Dept. of Energy Technology, Aalborg University  
Aalborg East, Denmark

[cli@et.aau.dk](mailto:cli@et.aau.dk), [zch@et.aau.dk](mailto:zch@et.aau.dk), [clb@et.aau.dk](mailto:clb@et.aau.dk), [zli@et.aau.dk](mailto:zli@et.aau.dk),

Per Lund, Peter Rønne-Hansen

Energinet.dk  
Fredericia, Denmark

[plu@energinet.dk](mailto:plu@energinet.dk), [prh@n1.dk](mailto:prh@n1.dk)

**Abstract**—Recently, the security and stability of power system with large amount of wind power are the concerned issues, especially the transient stability. In Denmark, the onshore and offshore wind farms are connected to distribution system and transmission system respectively. The control and protection methodologies of onshore and offshore wind farms definitely affect the transient stability of power system. In this paper, the onshore and offshore wind farms are modeled in detail in order to assess the transient stability of western Danish power system. Further, the computation of critical clearing time (CCT) in different scenarios is proposed to evaluate the vulnerable areas in western Danish power system. The result of CCTs in different scenarios can evaluate the impact of wind power on power system transient stability. Besides, some other influencing factors such as the load level of generators in central power plants, load consumption level and high voltage direct current (HVDC) transmission links are taken into account. The results presented in this paper are able to provide an early awareness of power system security condition of the western Danish power system.

**Keywords**- *Critical clearing time, offshore wind farm, onshore wind farm, transient stability, western Danish power system, wind power penetration.*

## I. INTRODUCTION

In the recent years, the electrical generation from wind has received a lot of attention and has been developing rapidly worldwide, due to the exhaustion of fossil fuel sources and the policy of greenhouse gas mitigation from power generation. However, many issues are raised when power system is integrated with large amount of wind generation system, in terms of power system operation, control and protection, etc. The issue of transient stability is becoming more and more important, since the wind power penetration is increasing rapidly, but the financial and regulatory condition have caused electric utility to build power systems with less redundancy and operate them closer to transient stability limits [1]. Hence, there are more and more challenges for the control and protection to maintain the security and stability of power system with large wind power penetration.

Transient stability of a power system is the ability to maintain synchronous operation when subjected to a large

severe disturbance, such as a 3-phase short circuit at the bus of an important generation plant, the loss of an important tie-line, or the loss of an important load, etc. [2], [3]. Typically, the time span to evaluate transient stability is short, within 10 seconds. Critical clearing time (CCT) is widely used as an important transient stability index which is defined as the maximum duration that a disturbance may sustain without losing the power system's capability of recovering to a normal operation condition [2].

Considerable number of studies have been conducted on the impact of wind generation on power system stability. In [4], the author compared the effect of variable speed wind power plant and that of conventional synchronous generator to voltage and transient stability and concluded that the modern wind power plants equipped with power electronic devices and low voltage ride through (LVRT) ability do not reduce the stability margin. In [5], the author analyzed transient and dynamic stability in a simple 3-machine network and concluded that the fixed speed induction generator (FSIG) based wind farms contributed to the system damping significantly but are vulnerable to network faults due to voltage stability issue. Doubly fed induction generator (DFIG) based wind farms can provide a superior transient performance in terms of voltage recovery ability following the fault. In [6], [7], specific scenarios have been examined in eastern Danish power system, but they only considered the traditional FSIG-based wind generators.

In this paper, the detailed models of onshore and offshore wind farms are developed to evaluate the transient stability of western Danish power system. The CCT is calculated in terms of iterative time-domain simulation. From the results of CCT in different scenarios, the impacts of wind power and other influencing factors on power system transient stability are analyzed.

In Section II, the key features of western Danish power system are presented. In Section III, detailed unit-specific models of onshore and offshore wind farms in DlgSILENT/PowerFactory are described. The simulation results are shown in Section IV which is followed by concluding remarks in Section V.

## II. WESTERN DANISH POWER SYSTEM

The western Danish power system is operated at 400kV and 150kV at transmission level and 60/20/10/0.4kV at distribution level. As shown in Fig. 1, the geographical map of western Danish transmission system [8], 6 central power plants (CPPs) with 9 large synchronous generators are connected to transmission system. Two offshore wind farms Horns Rev 1 and Horns Rev 2 with capacities of 160MW and 209MW were commissioned in 2002 and 2009 respectively, while onshore wind farms with 2232MW in total still composes major part of wind generation which is distributed all over Denmark. The reactive power generation and voltage control is mainly provided by large CPPs with excitation control. Besides, two synchronous compensators at 150kV substations close to the connection points of HVDC links to Norway and Sweden, with capacity of 160MVA and 100MVA respectively. Currently, the power balance is maintained by the governor action of CPPs, while in the future, some large offshore power plants subjected to the new grid code will play part of the role in keeping power balance and maintaining the power system stability. Table I shows the capacity of generations and load in western Danish power system.

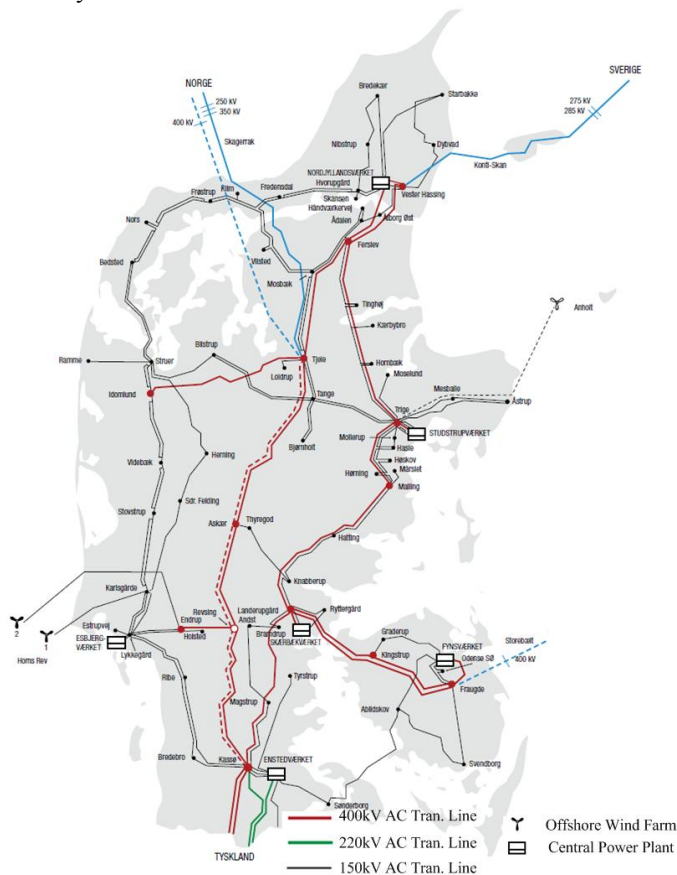

Figure 1. The western Danish power system in 2010[8].

The western Danish power system is characterized by its significant incorporation with wind energy. As shown in Fig.2, by the end of 2011, the amount of wind generation capacity in

Denmark approached 3927MW and the annual share of wind generation was 28.2% [10].

The interconnection of western Danish power system to external grid is so strong that the fluctuation of wind energy can be fully compensated by ENTSO-E grid. To the north, the western Danish power system is connected to Norway and Sweden via HVDC links. The capabilities of 3 HVDC links to Norway are 275MW, 275MW and 500MW, and the capabilities of 2 HVDC links to Sweden are 380MW and 360MW respectively. To the south, it is connected to the European Network of Transmission System Operators for Electricity (ENTSO-E) synchronous area via 2 400kV and 2 200kV AC transmission lines to Germany. To the east, the HVDC link--- “Great Belt” with capacity of 600MW was commissioned in July 2010 interconnecting western Danish power system and eastern Danish power system. The abundance of hydro power generation in Norwegian and Swedish power systems can cooperate with the wind power generation in Denmark and Germany. Hence, the 400kV transmission system often acts as the power transmission corridor, which is subject to significant amount of active power transport.

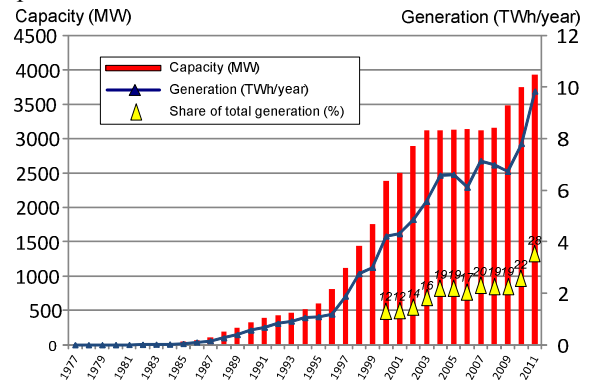

Figure 2. Installed wind capacity, annual wind generation and capacity factors in Denmark from 1977 to 2011. [10]

TABLE I. SOME KEY FIGURES OF WESTERN DANISH POWER SYSTEM IN 2011[9]

Production, Consumption and Power Exchange	Power (MW)
Production, Total	7732
Central Power Plant	3147
Local CHP	2017
Onshore Wind Turbines	2232
Offshore Wind Farms	369
Other DGs	326
Minimum Load	1306
Maximum Load	3664
Exchange Capacity Ex. (+)/ Im. (-)	3730/-3230
Maximum Capacity to ENTSO-E Ex. (+)/ Im. (-)	1780/-1500
Maximum Capacity to Sweden Ex. (+)/ Im. (-)	740/-680
Maximum Capacity to Norway Ex. (+)/ Im. (-)	1000/-1000
Maximum Capacity to Eastern Denmark Ex. (+)/ Im. (-)	590/-600

In order to keep the active power balance in the grid, the number of the large CPPs which are responsible for reactive power and voltage control as well as maintaining the power

system stability has to be reduced. According to the system plan from Energinet.dk [8], the number of large synchronous generators will reduce to 5 in the next a few years. Due to the fluctuation of wind power and the difference of dynamic and transient characteristics between wind power plant and conventional power plant, the operation, control and protection of Danish power system with a large amount of wind power need to be developed. The issue of security and stability of power system is expected to face various potential challenges.

### III. MODELING OF WIND FARMS

#### A. Fixed speed induction generator (FSIG)

Most of onshore wind turbines in Danish power system are equipped with FSIGs. The FSIGs have been represented by the asynchronous generator model in DIGSILENT. Fig. 3 shows the control diagram of wind turbine model with FSIG, which contains the aerodynamic model, shaft model, protection and emergency stop models.

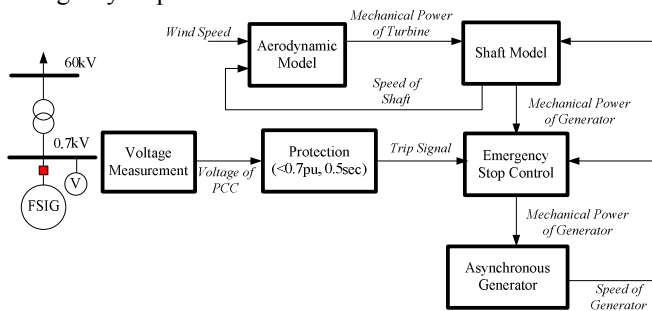

Figure 3. The model of onshore wind farm with FSIG [8].

The parameters of the wind turbines and FSIGs are selected to match the typical onshore wind farms, shown in Table II, while the active and reactive power outputs as well as the inertias of each wind farm are different, according to the detailed data of installed wind farms in Denmark [10].

The power system with high wind penetration can exhibit voltage instability issue during and after the fault, because of the high reactive power absorption from the grid. As shown in Fig.4, the sharp voltage drop results in the imbalance between mechanical torque and electromagnetic torque. FSIG accelerates, increasing the absolute value of slip rate  $s$ , enabling much more reactive current to pass through the leakage reactance  $X_r$ , which exacerbates the voltage decrease. So the protection relay should trip the wind farm when the voltage of point of connection (POC) is below  $0.7p.u.$  for more than  $0.5sec.$

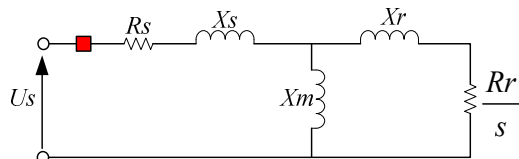

Figure 4. The model of FSIG [8].

TABLE II. DATA OF ONSHORE WIND TURBINE WITH FSIG

FISG Data and Wind Turbine Data	Power (MW)
Stator resistance $R_s$ (pu)	0.00744
Stator reactance $X_s$ (pu)	0.09266
Mag. reactance $X_m$ (pu)	4.0252
Rotor resistance $R_r$ (pu)	0.00667
Rotor reactance $X_r$ (pu)	0.01168
Pole pairs	2
Turbine radius (m)	24
Rated mechanical power (MW)	0.765
Gear ratio	67.57

#### B. Horns Rev 1: wind farm with DFIG

Horn Rev 1 is the first large scale wind farm in the world. A total number of 80 Vestas V80-2.0MW units with DFIG, capable of producing 160MW, were installed in 2002.

The wind farm has been represented by aggregated model of 80 2MW DFIGs in DIGSILENT. Fig. 5 shows the control diagram of DFIG wind farm, containing the models of pitch control, aerodynamic, 2-mass shaft, MPPT control, speed control, over-frequency active power reduction control, power control, current control and protections (crowbar for over-current protection, over-speed protection and over- under voltage protection).

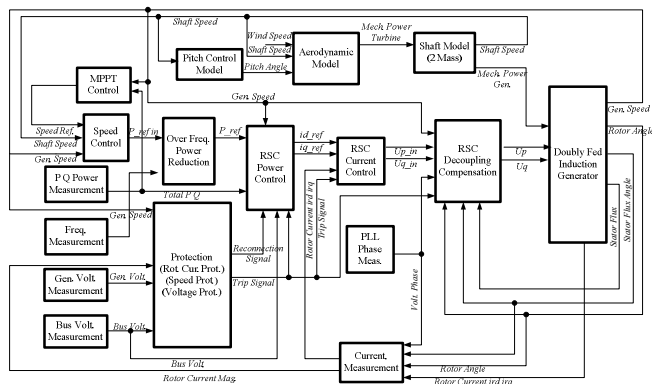

Figure 5. The model of offshore wind farm Horns Rev 1 with DFIG [8].

The wind farm integration complies with the Danish grid code that wind power plant must be able to withstand voltage drop to 20% of the nominal voltage in the point of connection over a period of minimum 0.5sec without disconnection. Besides, the wind power plant must have a control function capable of controlling the reactive power in Area B, as specified in Fig.6.

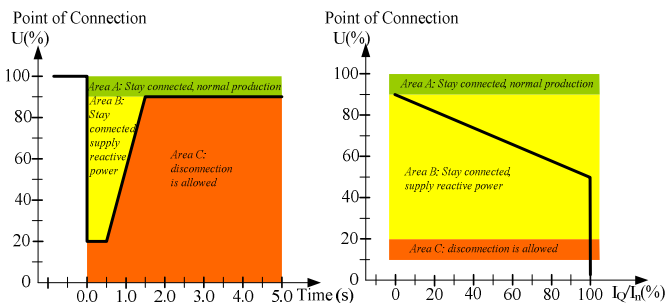

Figure 6. Requirements of (a) LVRT and (b) reactive power supply for wind power plant larger than 1.5MW [12].

### C. Horns Rev 2: wind farm with induction generator and full rated converter (IG-FRC)

Horns Rev 2 is the wind farm with full-rated converter consisting of 91 Siemens Wind Power SWP 2.3-93 wind turbines with total generation capacity of 209MW.

The detailed model of Horns Rev 2 is represented by aggregated model of 93 2.3MW asynchronous generators and the models of generator side converter and grid side converter. The control diagram is shown in Fig. 7, containing three main parts: generator model, generator side converter model and grid side converter model. The chopper is connected when the DC bus voltage is above 1.2p.u., while the protection and LVRT control module ensure the integration of Horns Rev 2 in accordance with Danish grid code as well.

The key parameters of offshore wind farms for Horns Rev 1 and Horns Rev 2 are shown in Table III.

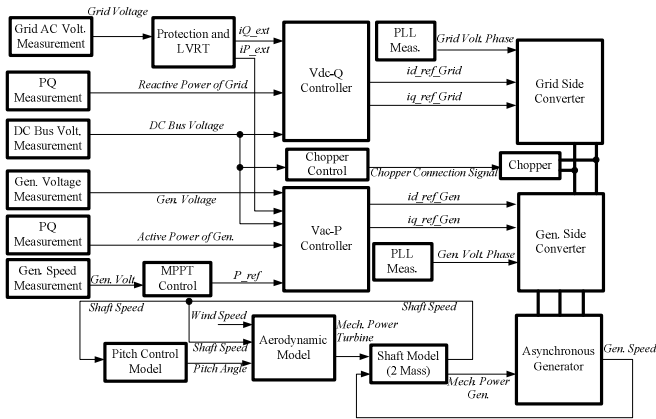

Figure 7. The model of offshore wind farm Horns Rev 2 with FRC [8].

TABLE III. DATA OF OFFSHORE WIND FARMS HORNS REV 1 AND 2

Name of wind farm	Horns Rev 1	Horns Rev 2
Turbine name	V80-2.0 MW	SWT-2.3-93
Manufacture	Vestas	Siemens
Rated power (MW)	2	2.3
Number of turbines	80	91
Total capacity (MW)	160	209.3
Turbine diameter (m)	80	93
Cut-in wind speed (m/s)	4	4
Rated wind speed (m/s)	16	13-14
Cut-out wind speed (m/s)	25	25
Power Density(m <sup>2</sup> /kW)	2.51	2.95
Generator type	4 pole DFIG	Asynchronous Gen
Output Voltage (V)	690	690

## IV. SIMULATION AND RESULT

### A. Transient stability assessment in terms of CCT

CCT is an important index for transient stability, which is usually calculated by iterative time domain simulation, more specifically, adjusting the fault duration time in the time-domain simulation to find out the maximum duration of a short circuit to maintain the synchronization of CPPs in the whole power grid.

Critical fault screening is to create short-circuits in every critical position in order to evaluate the vulnerable areas in

terms of transient stability. DIGSILENT Programming Language (DPL) is used for critical fault screening of western Danish power system. For each transmission line, a 3-phase short circuits event is created at both terminals of transmission lines, since the most critical disturbance of N-1 contingency is the fault close to the buses. A switch event trips the faulted transmission line after the time duration of short-circuit. The bisection method is adopted to accelerate the computation of finding out CCT, and the accuracy of CCT is 0.001sec.

The CCT is dependent on many factors, such as generators' output level, the fault location and fault type, voltages and power flows before the disturbance. So some scales are given to tune the power production and power consumption for creating different scenarios. Table IV show the scales and the power pattern of the basic scenario, in which the power production and consumption are moderate.

TABLE IV. THE POWER PATTERN OF THE BASIC SCENARIO

Scale	Percentage (%)
Load level	75
Load of CPP generation	50
Load of CHP generation	50
Load of other DG units generation	90
Wind power generation of offshore wind farm	80
Wind power generation of onshore wind farm	50
HVDC to Sweden	75(Ex)
HVDC to eastern Denmark	100 (Ex)
HVDC to Norway	-50(Im)

After critical fault screening, CCTs at all the terminals of 400kV transmission lines of western Danish power system in the basic scenario is calculated out, as shown in Fig. 8. Four vulnerable areas in terms of transient stability can be identified and highlighted by red circles, in which the CCT are generally below 700ms. Because these short-circuit locations are close to CPPs or central hub substations, the disturbances in these locations are easily to result in the out-of-step of the nearest generator. So it is reasonable to select 8 critical short-circuit locations to evaluate the impact of power flow pattern on transient stability.

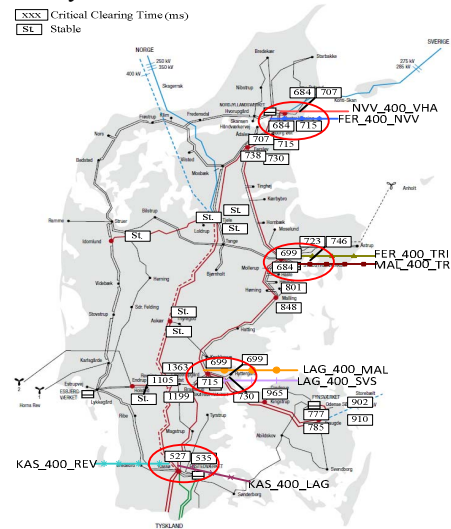

Figure 8. The result of critical fault screening in western Danish power grid.

### B. Four typical scenarios in 2011

Fig. 9 shows the hourly wind power generation and total consumption of western Danish power system in the 2011[9]. The jagged red line implies that the load in working days is higher than that in holidays, while the wind generation is changing irregularly. It can be noted that the wind power generation even exceeded the total load consumption in some short-term periods.

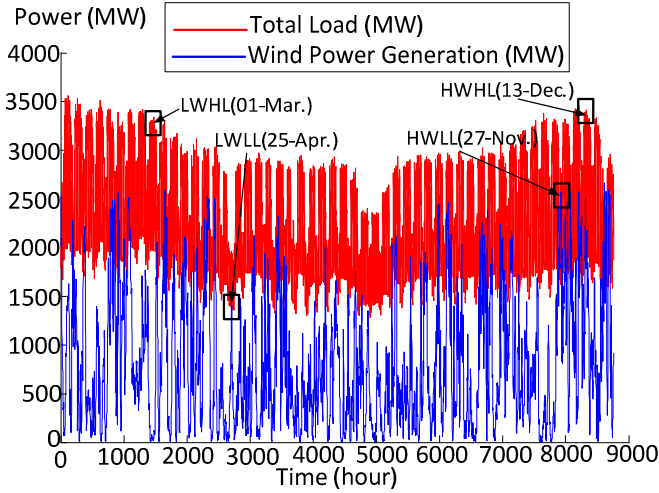
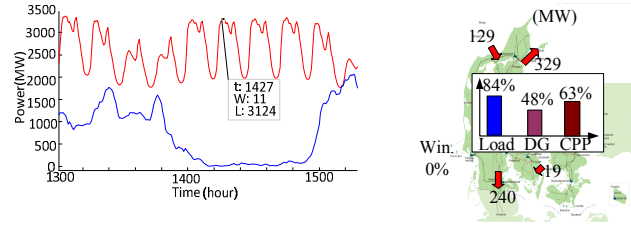
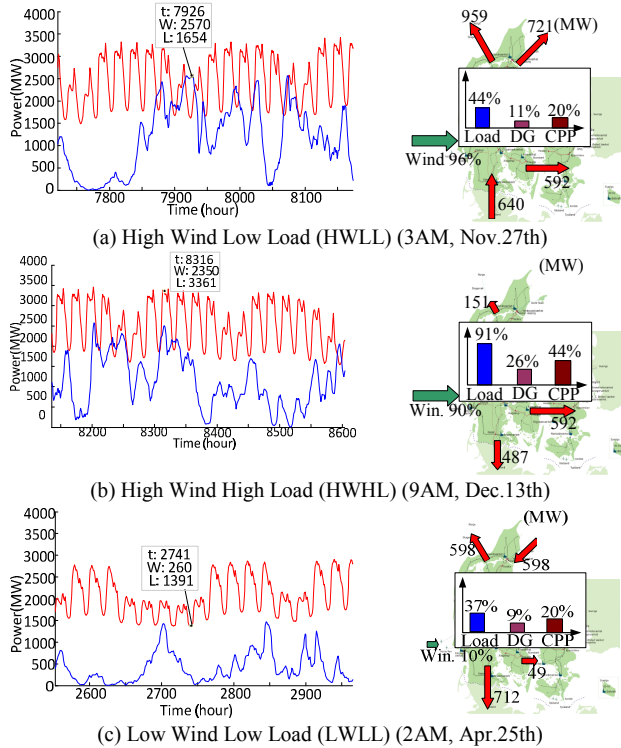

Figure 9. The hourly wind power generation and total load of western Danish power system in 2011.



(d) Low Wind High Load (LWHL) (8AM, Mar.1st)

Figure 10. The wind generation, load and power exchange in 4 typical scenarios.

In order to evaluate the impact of wind generation and load level on transient stability, 4 typical scenarios are selected, high wind low load (HWLL), high wind high load (HWHL), low wind low load (LWLL) and low wind high load (LWHL). The wind power generation, load and exchange power with external grid in these 4 typical scenarios are shown as Fig. 10. The CCTs of the 4 typical scenarios are calculated for the faults located in the 8 critical positions, as shown in Fig. 11. The results of CCTs are between 0.1sec and 1.0sec, so when the CCT is equal to 1.0sec, the system is absolutely stable.

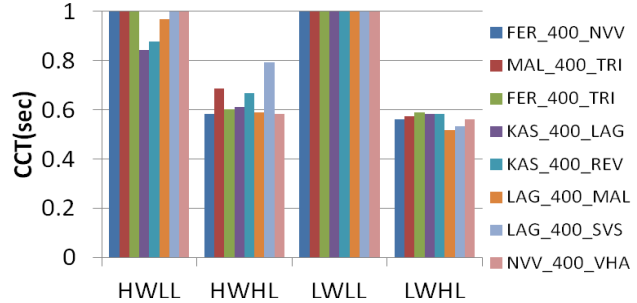

Figure 11. The critical clearing time of 4 typical scenarios.

Compared with the results of CCTs in these 4 scenarios, one can get the conclusions that the most influential factor is the load of the CPP, since the higher load of CPPs implies the less reserve in these CPPs in emergencies. Besides, if the power system is in low load scenarios, the transient stability is better because the loads of CPP are usually lower. Generally, when the wind power generation is high, the transient stability is better because the wind power generation takes part of the total generation, thus decreases the load of CPPs.

### C. The influencing factors analysis of transient stability

As mentioned earlier, the transient stability is highly dependent on the power flow pattern before the disturbance. The power flow pattern can be decided by many influencing factors, such as the load of CPP, load level, wind generation level as well as the power exchange with external grid. In order to evaluate the impact of these main factors on transient stability individually, the following configurations are necessary:

- (1) A fundamental scenario should be given, as shown in TABLE V. Then the main influencing factors can be changed one by one in order to analyze their respective impacts.

- (2) This fundamental scenario should be connected with synchronous ENTSO-E grid and disconnected with asynchronous Nordel grid, because the impact of HVDC can not be coupled with other impacts.
- (3) When considering the impact of wind power generation and load, we should not change the load of CPP and power balance should be kept by one external grid (i.e. ENTSO-E synchronous grid). Since the research subject is the rotor-angle stability of CPPs, the generation of CPP can not be changed while considering other impacts.

TABLE V. THE POWER PATTERN OF THE FUNDAMENTAL SCENARIO

Scale	Percentage (%)
Load level	50
Load of CPP generation	80
Load of CHP generation	50
Load of other DG units generation	50
Wind power generation of offshore wind farm	50
Wind power generation of onshore wind farm	50
HVDC to Sweden	0
HVDC to eastern Denmark	0
HVDC to Norway	0

The impact of load of CPP on transient stability is shown as Fig.12. The CCTs at the 8 critical short-circuit events decrease with the increase of load of CPPs from 30% to 100%. That is because the heavier load of CPP, the less reserve of generators when they are subjected to disturbances. The load of CPP is the most dominant impact on transient stability, as CCTs drop evidently from 0.95sec to 0.1sec. When CCT is below 0.1sec, the system can be deemed as unstable in transient stability.

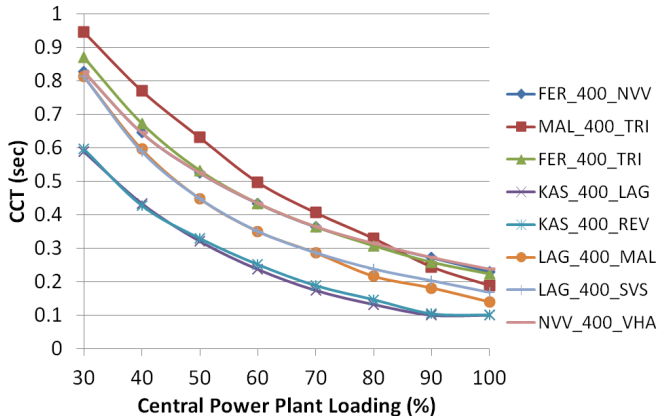

Figure 12. The critical clearing time w. r. t. the load of central power plant.

The transient stability is also dependent on the load. With the increase of the load level in all load buses of western Denmark, the power import from HVAC connection of the ENTSO-E grid increases in order to keep the power balance. When the load varies from 30% to 130%, CCT increases from minimum 0.1sec to maximum 0.47sec regularly, as shown in Fig.13.

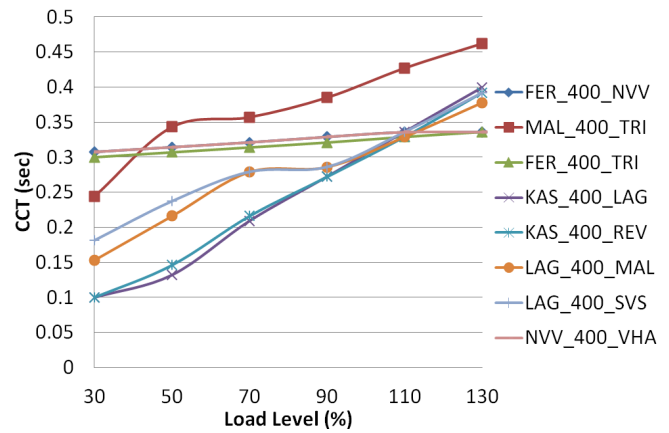

Figure 13. The critical clearing time w. r. t. the load level.

Since the detailed model of onshore and offshore wind farms have been built, the impact of wind power generation on transient stability can be accurately evaluated. As shown in Fig.14, the increase of wind power generation penetration deteriorates the transient stability. It can be concluded that the wind power penetration can not exceed 60% when the HVDC links connected with Nordic countries are disconnected. The reason is that the most part of wind power generation is FSIG-based wind generation, which is vulnerable to grid faults [5].

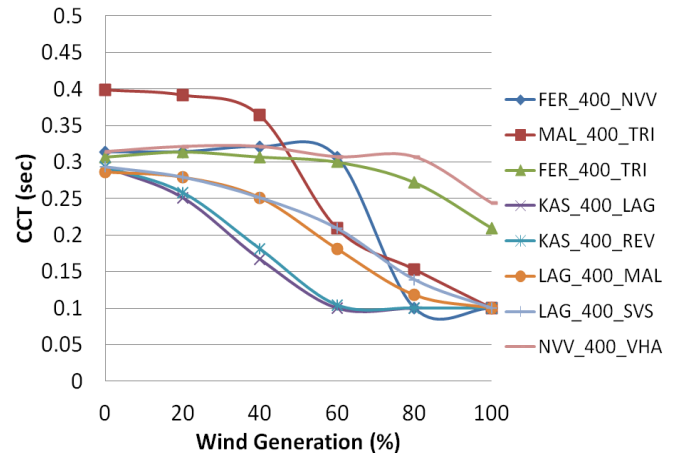

Figure 14. The critical clearing time w. r. t. the wind generation level.

HVDC links with emergency control usually improves the transient stability. Nevertheless, with the same control mechanism, the power exchange before the disturbance has different effect, mainly dependent on the fault position in the power grid. As shown in Fig.15, when the short circuit points take place in the north part of Denmark (i.e. FER\_400\_NVV, FER\_400\_TRI and NVV\_400\_VHA), close to connection points of HVDC, the transient stability should be better if these HVDC links export or import some amount of power before the disturbance. However, when the short circuit points take place in the other part of Denmark, the transient stability improves with the increase of HVDC power output, from import 60% to export 60%, intuitively because the power

output and power consumption can contribute to the decreasing area of the generators [13], [14].

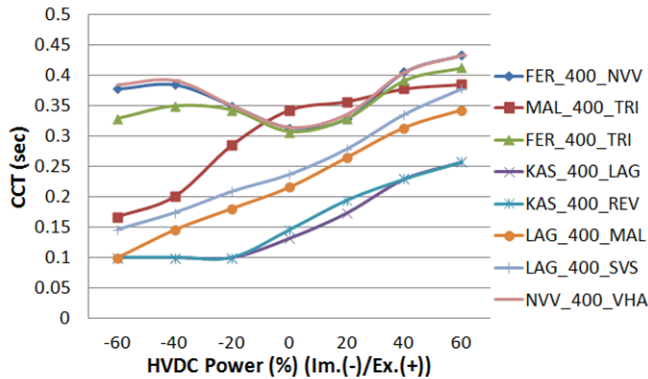

Figure 15. The critical clearing time w. r. t. the HVDC power.

## V. CONCLUSION

This paper firstly described the modeling of Danish wind farms in DiGSILENT, both onshore and offshore wind farms with different types (FSIG, DFIG & IG-FRC). Then, critical fault screening is conducted all across western Danish power system to find out the vulnerable areas and vulnerable points in terms of transient stability, and 8 critical locations are selected as the disturbances for examining the transient stability. Furthermore, 4 typical real scenarios in the year of 2011 are selected to evaluate the impact of wind generation level and load on transient stability. Finally, the transient stability is evaluated by calculating critical clearing time in a variety of power flow patterns. The influencing factors of transient stability are analyzed individually, such as the output of central power plant, load level, wind generation level and power transmission of HVDC links.

In conclusion, before the disturbance, the transient stability is highly dependent on the power flow pattern. The output of CPPs is the most dominant factor of transient stability. The higher load of CPPs means the less reserve and worse transient stability. Besides, under the same load of CPP, the less load consumption and the more wind generation (especially FSIG-based) are generally harmful to transient stability. The impact of the transmission power in HVDC links on transient stability is highly dependent on the position of the disturbances.

## ACKNOWLEDGMENT

The author would like to acknowledge Per Lund and Peter Rønne-Hansen from Energinet.dk for their kindly support for this work.

## REFERENCES

- [1] P. Kundur, *Power System Stability and Control*. London, U.K.: McGraw-Hill, 1994.
- [2] M. A. Pai, *Transient Stability of Power System*. Massachusetts, USA: Kluwer Academic Publishers, 2000.
- [3] J. Machowski, J. W. Bialek and J. R. Bumby, *Power System Dynamics: Stability and Control*. (Second Edition). West Sussex, U. K.: John Wiley & Sons, Inc., 2008.
- [4] E. Muljadi, C. P. Butterfield, B. Parsons, "Effect of variable-speed wind turbine generator on stability of weak grid," *IEEE Trans. Power Systems*, vol. 22, issue 1, pp. 29-36, Mar. 2007.
- [5] O. Anaya-Lara, F. M. Hughes, N. Jenkins, G. Strbac, "Influence of wind farms on power system dynamics and stability," *Wind Engineering*, vol. 30, no. 2, pp. 107-127, 2006.
- [6] V. Akhmatov, "System stability of large wind power networks: a danish study case," *Int. Journal of Electrical Power and Energy Systems*, vol. 28, no. 1, pp 48-57, Oct. 2005.
- [7] C. Jauch, P. Sørensen, I. Norheim, C. Rasmussen, "Simulation of the impact of wind power on the transient fault behavior of the Nordic power system," *Int. Journal of Electrical Power and Energy Systems*, vol. 77, no. 2, pp 135-144, Mar. 2007.
- [8] System plan of Danish power system 2010. Available [online]. <http://www.energinet.dk/SiteCollectionDocuments/Danske%20dokumenter/Om%20os/Systemplan%202010.pdf>
- [9] Hourly Danish power system data in 2011. Available [online]. <http://www.energinet.dk/EN/EI/Engrosmarked/Udtraek-af-markedsdata/Sider/default.aspx>
- [10] Statistic data of wind farms in Denmark. Available [online]. [http://www.ens.dk/da-DK/Info/TalOgKort/Statistik\\_og\\_noegletal/Oversigt\\_over\\_energisektoren/Stamdataregister\\_vindmoeller/Sider/forside.aspx](http://www.ens.dk/da-DK/Info/TalOgKort/Statistik_og_noegletal/Oversigt_over_energisektoren/Stamdataregister_vindmoeller/Sider/forside.aspx)
- [11] Siemens Power Generation, "Technical Specification". Available [online]. [http://www.ens.dk/da-DK/Info/TalOgKort/Statistik\\_og\\_noegletal/Oversigt\\_over\\_energisektoren/Stamdataregister\\_vindmoeller/Sider/forside.aspx](http://www.ens.dk/da-DK/Info/TalOgKort/Statistik_og_noegletal/Oversigt_over_energisektoren/Stamdataregister_vindmoeller/Sider/forside.aspx)
- [12] Technical regulation 3.2.5 for wind power plants with power output greater than 11kW. Energinet.dk. 2010.
- [13] M. H. Haque, "Equal-area criterion: an extension for multimachine power systems" *IEE Proceedings on Generation, Transmission and Distribution*, vol. 141, no. 3, pp. 191-197, May. 1994.
- [14] O. G. C. Dahl, "Stability of the General 2-Machine System," *Transactions on American Institute of Electrical Engineers*, vol.54, no.2, pp.185-188, Feb. 1935
- [15] M. H. Haque, "Equal-area criterion: an extension for multimachine power systems" *IEE Proceedings on Generation, Transmission and Distribution*, vol. 141, no. 3, pp. 191-197, May. 1994.