



Aalborg Universitet

AALBORG UNIVERSITY
DENMARK

Explore the Capability of ESPAR Antennas for Low Cost Communication

Han, Bo; Kalis, A; Papadias, C.; Nielsen, Rasmus Hjorth; Prasad, Ramjee

Publication date:
2012

Document Version
Early version, also known as pre-print

[Link to publication from Aalborg University](#)

Citation for published version (APA):

Han, B., Kalis, A., Papadias, C., Nielsen, R. H., & Prasad, R. (2012). *Explore the Capability of ESPAR Antennas for Low Cost Communication*. Paper presented at The 28th Conference on Technologies and Visions for a Sustainable Wireless Internet, Athens, Greece.

General rights

Copyright and moral rights for the publications made accessible in the public portal are retained by the authors and/or other copyright owners and it is a condition of accessing publications that users recognise and abide by the legal requirements associated with these rights.

- ? Users may download and print one copy of any publication from the public portal for the purpose of private study or research.
- ? You may not further distribute the material or use it for any profit-making activity or commercial gain
- ? You may freely distribute the URL identifying the publication in the public portal ?

Take down policy

If you believe that this document breaches copyright please contact us at vbn@aub.aau.dk providing details, and we will remove access to the work immediately and investigate your claim.

Explore the Capability of ESPAR Antennas for Low Cost Communication

Bo Han, Antonis Kalis, *Senior Member, IEEE*. Constantinos Papadias *Senior Member, IEEE*.
Rasmus Nielsen, *Member, IEEE*. Ramjee Prasad, *Fellow, IEEE*

Abstract—ESPAR antenna systems are composed of one active and several parasitic elements and by changing the characteristic of the parasitic elements on the antenna, the radiation pattern will also change. Such characteristic makes ESPAR antenna useful in many applications, e.g., single RF MIMO transmission. However, for higher modulation schemes like 16-QAM, more radiation patterns are needed which require a wider control range on the parasitic antenna load. In order to explore the capability of ESPAR antennas, negative resistance was proposed, but their values cannot be easily controlled both on the real and imaginary part. So a matching network is required to control the load value. This paper presents an idea of adjusting the parasitic ESPAR antenna loads with controllable passive elements. According to simulation, the control circuit consumes less than 1mW power on 64 patterns selection, which explores the capacity of ESPAR antenna for high order modulation applications.

Index Terms—Single RF MIMO; ESPAR; 16-QAM; Impedance Matching; Low Cost; Address-searching.

I. INTRODUCTION

ESPAR antennas bring a promising future for many low cost communication proposals, such as single RF MIMO communication [1] which is investigated more and more in recent research papers. Because of the low complexity and low power consumption characteristic of the ESPAR antenna, it is an ideal antenna for portable mobile devices.

Single RF MIMO transmission can be implemented by using an ESPAR antenna with a single active and one or two parasitic elements [2]. By switching among the radiation patterns driven by the changing characteristic of parasitic elements, such antennas can function as conventional MIMO transmission without additional RF chain, thus the main power consumption is very low.

Previous research on such system implementation is limited to simple modulation schemes, e.g. PSK modulation. In order to fully explore the capability of ESPAR antennas for single RF MIMO transmission, higher order modulation schemes have to be investigated. Thus, either more parasitic elements are needed or a wider load range of the single parasitic element. This paper focuses on the latter.

As mentioned in [3], only one parasitic and one active element are used for single RF MIMO uplink and the load impedance of the parasitic elements is changed by using a negative resistance circuit. Due to the power constrain on the active circuit, the parasitic element can only use a limited number of load values. This results in limitations in the radiation pattern that can be driven from such an ESPAR antenna, so only simple modulation scheme can be adopted, e.g., QPSK. In order to have more complex modulation while

keeping the antenna as simple as it was before, a better load control circuit is needed. The load control circuit should have the capability of turning the impedance within a wider range, so that more radiation patterns can be mapped on.

Moreover, the negative resistance generated from a CMOS circuit in [3] can only be controlled on the real part and each time the real part changes, the imaginary part also changes. However, mapping the circuit to the radiation pattern requires that both the real part and imaginary part of the load impedance can be changed independently and accurately, so an adjusting network from the negative resistance circuit to the parasitic antenna is needed. This paper will present the idea of the implementation of such an adjusting network and with this method we can explore the capacity of ESPAR antennas for low cost single RF MIMO transmission with 16-QAM modulation.

The organization of this paper is the following: Section II gives the theoretical analysis, Section III presents the negative resistance and matching and Section IV is the comparison between simulated result and theoretical values. Section V concludes the paper.

II. REQUIREMENT OF ESPAR ANTENNA

A. System Analysis

Conventional MIMO transmission is implemented by using two or more data streams going into different RF chains, while single RF MIMO transmission uses the same principle but only one active RF chain is used and MIMO is implemented by switching on the different radiation patterns.

We are assuming the use of a single active single parasitic ESPAR antenna element for 2x2 MIMO transmission. One data stream goes to the active RF chain; the other data stream first goes to the mapping circuit, where it will be combined with the first data stream. Then their combination is used as a mapping control, to switch among the radiation patterns of the antenna. The mapping circuit actually changes the load impedance of the parasitic element on the antenna, when the antenna load changes, the radiation pattern also changes. In this way, the data stream combination which mapped to the parasitic arrays will switch among the radiation patterns and, thus, a low cost single RF MIMO transmission is implemented.

$$AF = S_1 b_1(\theta, \varphi) + S_2 b_2(\theta, \varphi)$$

$$\Rightarrow AF = S_1 \left(b_1(\theta, \varphi) + \frac{S_2}{S_1} b_2(\theta, \varphi) \right)$$

The equation above gives the antenna factor with

combination of the two data streams used in 2X2 MIMO transmission, S1 is from the first data stream, and S2 is from the second data stream, b1 and b2 are the two basis patterns.

B. Antenna Impedance Requirement

We are assuming that such a single RF MIMO transmission adopting the 16-QAM modulation, and the active element and parasitic element on the ESPAR antenna have an inter-element space of 1/16 wavelength. According to the rough simulation, the minimal load impedance for the 16-QAM pattern is around -65ohm on the real part and around -80ohm on the imaginary part.

As mentioned in [3], by using active CMOS circuit, we could generate a negative resistance up to -230ohm on the real part and -110ohm on the imaginary part. Assuming the parasitic antenna has the self-impedance of 50+0i ohm at 2.5GHz, in order to have the combined load value satisfy the radiation requirement, a matching circuit is required between the negative resistance circuit and the parasitic antenna element.

For a 16-QAM modulation, the combination of two data streams will generate 256 values. Due to symmetry, only 64 different values are needed. The next section will present this matching circuit, which also does the function of switching among the patterns.

III. MAPPING AND SWITCHING

A. Mapping to the patterns

The topology of the proposed matching antenna system is shown in Fig. 1. One active element and one parasitic element are coupled on the ESPAR antenna and by changing the load impedance of the parasitic element, the radiation of the whole antenna will change. The negative resistance circuit will generate a constant value, which is considered as large as possible, e.g., -230ohm. The proposed adjusting network is placed between the parasitic antenna and the negative resistance circuit.

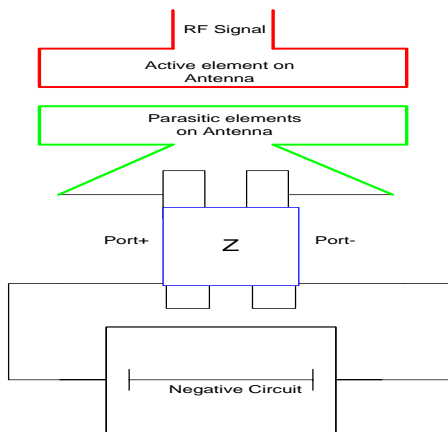

Fig. 1 Topology of impedance control for the parasitic antenna.

The adjusting network has three main functions: first, it will function as the mapping circuit as mentioned in Section II, which will switch among the 64 load values with control signal generated from combination of the two data streams; second, the adjusting network will match the negative resistance to the pre-defined load values with the parasitic

antenna element; finally a very important function of the matching network is to avoid oscillation as the negative resistance generation block follows the principle of positive feedback, so if $|R_{neg}| > R_{antenna}$ and phase shift > 360 degrees, oscillation will happen. Proper design of the matching block is required for reliability and stability issues.

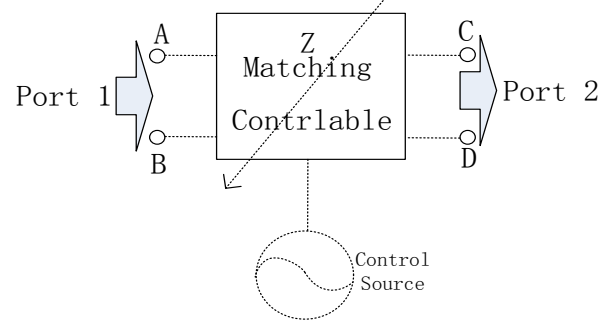

Fig. 2 Topology of a signal controlled Matching network.

The control signal for the matching network is generated according to the data stream S_2/S_1 ; A typical design method of the control unit is using voltage controlled variable resistor and inductor for the real part and imaginary part separately. The impedance on the real part Z_1 and on the imaginary part Z_2 will be under the following relation with mapping signal S_2/S_1 :

$$Z_1 = f_1(u_1(\frac{S_2}{S_1}, \sigma), t)$$

$$Z_2 = f_2(u_2(\frac{S_2}{S_1}, o), t)$$

Here the coefficient σ and o are the real part influence factor and imaginary influence factor separately; the time factor t indicates the impedance is frequency dependent. Mapping coefficient u_1 and u_2 indicate the influence of the mapping control. Such a system requires switching among the radiation patterns randomly and the control signal should have the random changing ability due to the data streams of S_2 and S_1 being random. Analog control is not capable of such random switching, so a digital control signal is proposed in the following section.

B. Digital switching among the patterns

As mentioned in Section II, a single RF 2x2 MIMO with 16-QAM modulation needs 64 radiation patterns. Therefore the impedance adjusting circuit must be able to switch among 64 different loads values. The proposed idea is shown in Fig. 3, where an ‘address searching’ method is used for the complex 64 patterns with just a control signal of 6 bits.

The control network in Fig. 3 is made using an 8X8 array with two 3-8 converters. RF Port 1 and RF Port 2 are connected to the negative resistance core and parasitic antenna respectively. Each cell inside the array is a digital switch with pre-settled value pairs (see Fig. 6). In this topology, only 6 bits are required for the 64 loads selection.

Each time the transmitted symbols are simply pre-coded and get 6 bits control signal for load selection, and this control signal will be decoded by the ‘address searching’ block (the two 3-8 converters) to get the right value.

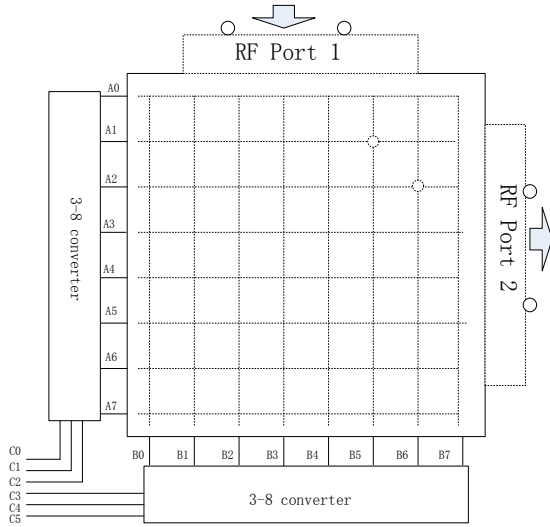

Fig. 3 Topology of address-searching network for 64 patterns switching.

For example, if the desired load is $-63.13 - j42.39$ ohm, which is pre-allocated in the matching unit of A1b5; then the control signal ‘101001’ is sent to the control line C5~C0; the control block (3~8 converters) decodes this control signal, then the address searching code ‘00000010’ appears in the A7~A0 branch and ‘0010000’ appears in the B7~B0 branch, the adjusting unit for this load is selected, which is A1B5. Actually this desired radiation pattern located in unit A1b5 can be any other 64 patterns in the pre-allocation, here the load of $-63.13 - j42.39$ ohm is chosen to have the design of the adjusting network in accordance with the radiation patterns. In the same way, the control signal for A2B6 is ‘110010’. By using this method, selection on 64 radiation patterns can be conducted with just 6 bits signals, which reduces the complexity on the control and selection

C. Matching to the proper value

Inside the matching network, there are 64 smallest matching units (Fig. 4) which adjust the negative resistance to the antenna load with a pre-defined resistance and inductance values. Through this matching, the antenna load impedance is set to the right value for the radiation pattern.

Fig. 4 gives the architecture of a smallest matching unit inside the matching network. An ‘L’ matching network is implemented inside each matching unit cell. Each matching circuit is connected between the negative resistance circuit and the parasitic antenna element.

The combined resistance value R'_s is composed of a negative resistance Z_N and a tuning resistance R_t , then the combined resistance R'_s is considered as the “source” resistance in the matching unit, which is responsible for the real part impedance values; the antenna impedance Z_L is considered as “load” in the matching unit; the tuning inductance value L_t and capacitance value C_t are

considered as “tuning” variables in the matching unit, which are responsible for the imaginary part of the impedance values.

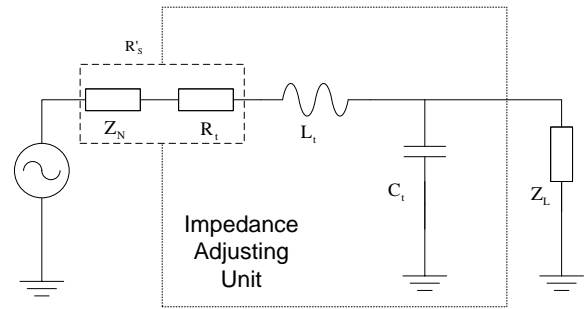

Fig. 4.A smallest matching unit inside the adjusting network.

Due to the fact that a serialized inductor and a parallelized capacitor can be considered as conjunction components at a specific frequency, only the inductor value L_t is used in the simulation, which is sufficient to change the load impedance on the imagery part.

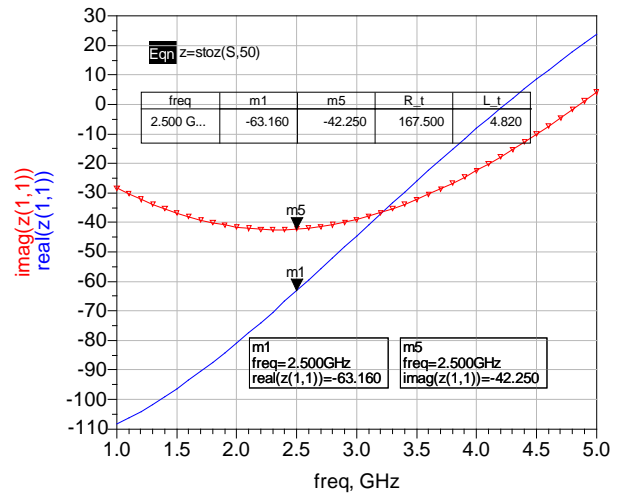

Fig. 5 Simulated impedance by using the matching network unit.

Fig. 5 gives the simulated load impedance values on the real part and the imaginary part. By tuning the value of R_t and L_t , we can get the simulated curve in Fig. 5. Two markers m1 and m5 indicate the real part and imaginary part of the load impedance value at 2.5GHz. From the curve, we know that with the tuning resistance 167.5 ohm and tuning inductance 4.82 nH, the simulated load impedance after matching is $-63.16 - j42.25$ ohm.

The simulation result indicates that the matching between the negative resistance to the antenna load is feasible with physical available passive components; the resistance value and inductance value are practical for implementation. The simulation also indicates that the simulated practical values have slightly differences from the theoretical values. This will be compared in the next section.

IV. SIMULATED RESULTS

A. Practical Values for 16-QAM

Assuming a 2X2 single RF MIMO transmission with

16-QAM modulation, the first data stream S_1 contains 16-QAM symbols A1~A16; the second data stream S_2 contains 16-QAM symbols B1~B16. So combination of S_2/S_1 has 256 values and due to identical symmetry, 64 load values for radiation patterns are required. For an easy indication, the first 16 values of such combination are shown in Table I:

TABLE I

VALUES OF THE PRACTICAL FIRST 16 SYMBOLS FOR SINGLE RF MIMO AND VALUES USED IN THE MATCHING NETWORK

Symbol	Re(Z)(ohm)	Im(Z)(ohm)	R_T(ohm)	L_T(nH)
A1b1	-31.66	-20.57	199.0	6.20
A1b2	-23.160	-6.12	207.5	7.12
A1b3	-10.66	-6.59	220.0	7.09
A1b4	-24.66	-44.44	206.0	4.68
A1b5	-63.16	-42.25	167.5	4.82
A1b6	-21.16	+32.04	209.5	9.55
A1b7	+0.14	+0.55	230.8	7.45
A1b8	-10.06	-52.61	220.6	4.16
A1b9	+11.34	-84.34	242.0	2.14
A1b10	+53.34	-9.89	284.0	6.88
A1b11	+15.34	-7.77	246.0	7.02
A1b12	+5.40	-45.39	231.2	4.62
A1b13	+13.34	-46.02	244.0	4.58
A1b14	+21.54	-31.25	252.0	5.52
A1b15	+14.54	-20.57	245.2	6.20
A1b16	-16.06	-35.96	214.6	5.22

Fig. 6 the first 16 loads and their tuning load values in the matching network.

The R_T (in ohm) and L_T (in nH) are the tuning values in each matching unit cell for the first 16 values of the 64 loads.

The tuning resistance ranges from 200 to 300 ohm, tuning inductance ranges from 2.14nH to 9.55nH and all these values are feasible for physical circuit implementation.

The Re(Z) and Im(Z) are the real part and the imaginary part of simulated load impedance values, which is generated from the tuning values R_T and L_T and all those values are plotted at 2.5GHz.

B. Comparison to the Theoretical Values

The proposed adjusting network is simulated according to the ideal impedance values. Due to the limitation on physical available resistance or inductance values, the simulated values are different from the ideal ones. Taking into account that the practical values have +/- 0.2~0.5 mismatching themselves, the simulated impedance value is imported back into the radiation pattern simulation system. The radiation patterns are compared in Fig. 7.

The dashed curve is the radiation pattern from theoretical impedance values and the constant curve is the radiation pattern from the simulated impedance values. This result shows that the practical values have perfect coexistence with the theoretical values.

This proves that the proposed architecture on weighting coefficient mapping for 16-QAM single RF MIMO communication is feasible. By exploring this more complex modulation scheme, the efficiency of using bandwidth increased dramatically, as well as the spectrum efficiency.

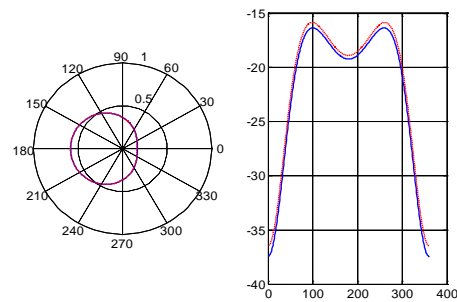

Fig. 7 Comparison between practical values and simulated values.

V. CONCLUSION

An adjusting network for exploring the capability of ESPAR antennas is introduced in this paper. With a given negative resistance, the proposed architecture can control the impedance accurately both on the real and the imaginary part. By adopting an address-searching method, the control circuit can switch among 64 patterns randomly with only a 6 bits signal. The proposed matching unit contains the physical feasible resistance and inductance values, which makes it possible to provide single RF MIMO transmission with 16-QAM modulation through a low cost ESPAR antenna.

ACKNOWLEDGMENT

This work is supported by European Commission funding on SmartEN (Grant No. 238726) under the Marie Curie ITN FP7 program. This work is also supported by collaboration between CTIF at Aalborg University and Athens Information Technology.

REFERENCES

- [1] Kalis, A.; Kanatas, A.; Papadias, C., "A Novel Approach to MIMO Transmission Using a Single RF Front End," IEEE Journal on Selected Areas in Communications, Volume: 26 Issue: 6, page(s): 972 – 980.
- [2] Barousis, V.; Kanatas, A.G.; Kalis, A., "Single RF MIMO Systems: Exploiting the Capabilities of Parasitic Antennas," 2011 IEEE Vehicular Technology Conference (VTC Fall), page(s): 1 - 5.
- [3] B. Han, V. Barousis, A. Kalis, A.G. Kanatas, "Active parasitic arrays for low cost compact MIMO transmitters," Proceedings of the 5th European Conference on Antennas and Propagation (EUCAP), page(s): 3663 – 3667.
- [4] Ida, I.; Takada, J.; Toda, T.; Oishi, Y.; "An adaptive impedance matching system and considerations for a better performance," the 5th International Symposium on Multi-Dimensional Mobile Communications, Vol.2, page(s): 563 - 567.
- [5] Bo Han, Mengmeng Liu, Ning Ge, "A UWB down convert circuit and measurement," 2010 International Conference on Microwave and Millimeter Wave Technology (ICMMT), page(s): 1472 - 1475.
- [6] Kerherve, E.; Naud, Ph.; Germain, G.; Jarry, P.; "RF antenna matching methods for radar cross section measurements," 9th International Conference on Electronics Circuits and Systems, Vol.1, page(s): 85 – 88.