



AALBORG UNIVERSITY
DENMARK

Aalborg Universitet

Mathematical Models for Room Air Distribution

Nielsen, Peter V.

Published in:
System Simulation in Buildings

Publication date:
1982

Document Version
Accepted author manuscript, peer reviewed version

[Link to publication from Aalborg University](#)

Citation for published version (APA):
Nielsen, P. V. (1982). Mathematical Models for Room Air Distribution. In *System Simulation in Buildings: Proceedings of the International Conference held in Liège (Belgium) on 6-8 December 1982* (1 ed., Vol. 1, pp. 455-470). Commission of the European Communities, COMAC - BME.

General rights

Copyright and moral rights for the publications made accessible in the public portal are retained by the authors and/or other copyright owners and it is a condition of accessing publications that users recognise and abide by the legal requirements associated with these rights.

- ? Users may download and print one copy of any publication from the public portal for the purpose of private study or research.
- ? You may not further distribute the material or use it for any profit-making activity or commercial gain
- ? You may freely distribute the URL identifying the publication in the public portal ?

Take down policy

If you believe that this document breaches copyright please contact us at vbn@aub.aau.dk providing details, and we will remove access to the work immediately and investigate your claim.

COMMISSION
OF THE EUROPEAN COMMUNITIES

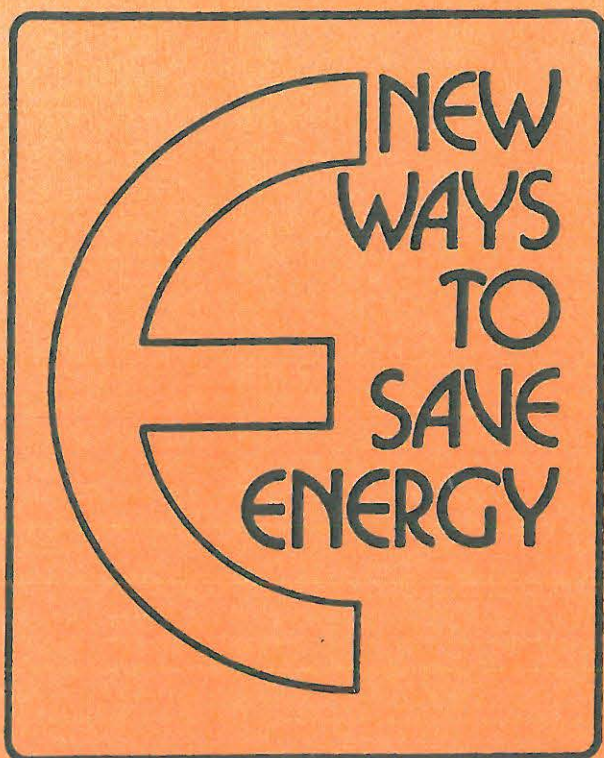

SYSTEM SIMULATION IN BUILDINGS

*Proceedings of the International Conference
held in Liège (Belgium) on 6-8 December 1982*

Mathematical models for room air
distribution

Peter V. Nielsen

MATHEMATICAL MODELS FOR ROOM AIR DISTRIBUTION

Author : Peter V. Nielsen
Address : Danfoss A/S
DK-6430 Nordborg
Denmark

Summary

A number of different models on the air distribution in rooms are introduced. This includes the throw model, a model on penetration length of a cold wall jet and a model for maximum velocity in the occupied zone. The paper discusses the important parameters in the dimensioning of an air distribution system in highly loaded rooms and shows that the amount of heat removed from the room at constant penetration length is proportional to the cube of the velocities in the occupied zone. It is also shown that a large number of diffusers increases the amount of heat which may be removed without affecting the thermal conditions. Control strategies for dual duct and single duct systems are given and the paper is concluded by mentioning a computer-based prediction method which gives the velocity and temperature distribution in the whole room.

1. Introduction

This paper will deal with some mathematical models describing the air distribution in an air conditioned room with recirculating flow. The examples are only given for two-dimensional flow in the interest of clarity. The models are restricted to different areas of a ventilated room which is indicated on fig. 1, and several of them are based on the wall jet which is established in the upper part of the room.

Area 1 refers to a model which is important because of its proximity to the supply opening. It describes the development of a two-dimensional wall jet from supply openings with different geometries.

The wall jet models are restricted to area 2 in fig. 1. One model describes the velocity decay in the wall jet and thus the terminal velocity in a wall jet with a length equivalent to the room length. Another model describes the penetration length of a cold wall jet. That is the distance from the supply opening to the area where the jet leaves the ceiling region and flows into the occupied zone.

Models in area 3 refer to the determination of the penetration length of the wall jet, and the maximum velocity in the occupied zone. They are mainly based on continuity and momentum flow considerations and prescribed velocity profiles. Some of them are based on experiments in different room geometries as shown in chapter 3.

The flow in the whole room may be predicted by numerical solution of the flow equations, area 4 in fig. 1. This is a complicated procedure but it gives the necessary parameters for a full description of the thermal comfort conditions in the room.

2. Models in the wall jet region

The supply opening in fig. 1 is placed close to the ceiling and it has the vertical dimension h . The air flow from the supply opening will develop into a wall jet which follows the ceiling and entrains air from the occupied zone to induce a recirculating air movement. This involves a flow many times larger than the supply flow, and the velocity in the wall jet decreases accordingly as it reaches the occupied zone. The velocity decay in the wall jet is given by the formula

$$\frac{U_x}{U_0} = K_p \sqrt{\frac{h}{x + x_0}} \quad (1)$$

where U_0 is the bulk supply velocity, U_x the maximum velocity at distance x from the supply opening and x_0 is the distance from the supply opening to a virtual origin of the wall jet, see fig. 2.

Equation (1) describes the wall jet in region 2 on fig. 1. The wall jet is established close to the openings in region 1, and it is possible to express all locations and types of diffusers which give two-dimensional flow by the constants x_0 and K_p in equation (1). Reference /1/ gives a discussion of the flow in region 1, and it is shown that the momentum flow in the wall jet is decreased if the supply slot is placed at a distance y_d from the ceiling. This is expressed by a decrease in K_p and an increase in x_0 further downstream from the opening, see fig. 2. A diffuser with vanes adjusted to a high spread or a diffuser giving the flow a high initial turbulence will have the same effect on K_p and x_0 /1/.

It is also shown that a diffuser consisting of a number of openings placed close to the ceiling may give a virtual origin in front of the diffuser.

The influence of different geometrical parameters on the flow in region 1 is very important because it also influences the velocity U_x in the wall jet and the velocity in the occupied zone, as shown in chapter 3. It is only possible to study the geometrical parameters around the supply openings by full scale experiments on the actual diffusers to be used in the room.

A model for the dimensioning of supply openings in the case of isothermal flow is based on equation (1) and area 2. A length, l_{Th} , called the throw, is defined as the distance from the opening where the maximum velocity U_x is equal to 0.2 m/s, and equation (1) gives:

$$l_{Th} = 25 K_p^2 U_o^2 h - x_o \tag{2}$$

The vertical height of the supply opening and the supply velocity are selected according to equation (2) in such a way that l_{Th} is equal to the room length or a fraction of the room length, and it is a general experience that reasonable velocities are obtained in the occupied zone in the case of isothermal flow.

The heat load in the room will have an influence on the wall jet. The thickness of a cold wall jet increases with the heat load and the jet may further separate from the ceiling at the distance x_s from the supply opening and flow down into the occupied zone. This will give rise to some limits on the thermal load in the room. The increasing thickness of the wall jet below the ceiling restricts the load in a room with a low ceiling to values which ensure that the velocity in the primary jet part of the occupied zone is below, for example, 0.2 m/s. Thermal comfort conditions may also be evaluated from a minimum penetration depth x_s . Hestad /2/ has shown that x_s/h can be expressed by the following equation

$$\frac{x_s}{h} = K_{sp} K_p^2 \left(\frac{U_o^2}{h \cdot \Delta T_o} \right)^{2/3} \tag{3}$$

where ΔT_o is the temperature difference between return and supply and K_{sp} is a constant expressing the location of the load and room geometry.

Fig. 3 shows the variation of K_{sp} as a function of x_s for different distributions of the heat source /2/. A very high K_{sp} is obtained when 50% of the load is placed at the wall below the supply opening and the other 50% is concentrated in the middle of the room. The concentrated heat source at the floor will counteract a separation of the jet at this distance and this may explain the maximum in the K_{sp} value. Hestad recommends a value of 2.5. K_{sp} is independent of x_s in the case of an evenly distributed heat source along the whole floor. Model experiments by Schwenke /3/ show that K_{sp} and x_s are dependent on the room length

and that the flow may have two steady solutions in very short rooms.

3. Models describing the reverse flow area

A wall jet will have a limited penetration into a deep room, see fig. 4. Entrainment in the jet means that air must be led back along the bottom of the room and this air will, at a given distance, disperse or deflect the jet. The penetration length l_{re} is defined as the distance from the wall with the supply opening to the point at the floor where the stream lines diverge - the reattachment point (the penetration length l_{re} is defined at isothermal flow).

The velocity is very low at distances from the supply openings which are greater than the penetration length, while the velocities are high at distances less than the penetration length, because large volumes of air are set into motion by the entrainment in the wall jet below the ceiling. The penetration length is therefore an important parameter in the discussion of room air distribution, and a supply system should always be designed in such a way that the ventilated section L is shorter than a calculated penetration length l_{re} at isothermal flow. This would, for example, be ensured in the room in fig. 4 by locating a set of ceiling-mounted supply openings close to the reattachment point.

Fig. 5 shows the penetration length measured by model experiments. The penetration length is rather independent of the relative height of the supply opening and the value $l_{re}/H = 4$ is obtained by a supply opening with a high K_p value. K_p values for practical diffusers are often smaller, and the results in fig. 5 indicate that a lower penetration length will be obtained in those cases.

A model based on continuity and momentum flow considerations established by Skåret /4/ shows that a penetration length l_{rm} , defined as the distance from the supply opening to the centre of recirculation, see fig. 4, is proportional to K_p^2 .

The maximum velocity in the reverse flow U_{rm} is located close to the floor at a distance of $\sim 2/3 L$ from the supply opening. The occupied zone does not include the jet below the ceiling and the jet at the end wall opposite the supply opening in the normal situation. The velocity U_{rm} will therefore be the maximum velocity in the occupied zone. Experiments and measurements show that U_{rm} is a simple function of a reference velocity U_L which is the velocity in an undisturbed wall jet of the length L from the actual supply opening. The reasons for this are that U_L contains information on the geometrical details around the diffuser (models in area 1) such as adjustable vanes and distance from ceiling.

Fig. 6 shows that U_{rm}/U_L is rather constant for practical dimensions of the supply opening ($U_{rm}/U_L \sim 0.7$ for $h/H < 0.01$). There is only a slight influence from the relative length of the room, L/H , and this is ignored in the figure. Fig. 6 is based on calculations of the two-dimensional recirculating flow in reference /5/ and it is in good agreement with measurements reported in reference /2/ and /4/.

The results in fig. 6 combined with equation (1) for a wall jet give the following model for the maximum velocity in the occupied zone of a room with ceiling-mounted diffusers and isothermal flow.

$$\frac{U_{rm}}{U_o} = 0.7 K_p \sqrt{\frac{h}{L + x_o}} \quad (4)$$

4. Dimensioning of an air distribution system

This chapter shows a dimensioning procedure for the air supply system based on equation (3) and (4). The main parameter is the thermal load per m^2 of the room Q . This load may be expressed as:

$$Q = \rho_o c_p U_o \Delta T_o \frac{h}{L} \quad W/m^2 \quad (5)$$

where ρ_o and c_p are density and specific heat respectively. U_o and ΔT_o can be expressed by U_{rm} and x_s . These are more relevant parameters for the evaluation of thermal comfort. Equation (3) for x_s and equation (4) for U_{rm} are introduced in equation (5) and the following equation is obtained ($x_o \ll L$):

$$Q = \rho_o c_p \left(\frac{U_{rm}}{0.7} \right)^3 \frac{K_{sp}^{3/2} L^{1/2}}{x_s^{3/2}} \quad W/m^2 \quad (6)$$

This equation is used for a room with an evenly distributed heat source along the whole floor, $K_{sp} = 1.56$, and it is assumed that the penetration length x_s shall be equal to or longer than the half room length, due to comfort considerations, and the following equation is obtained:

$$Q_{max} = 1.9 \cdot 10^4 \frac{U_{rm}^3}{L} \quad W/m^2 \quad (7)$$

where U_{rm} and L are in m/s and m respectively.

Equations (6) and (7) show that the thermal load which may be handled is proportional to U_{rm}^3 . It may thus be concluded that U_{rm} should be as high as acceptable in the case of cooling, and this necessitates a reduction in supply velocity in the heating season if low air temperatures are used in this period.

It is further shown that the maximum thermal load Q varies inversely with the length L of the ventilated section. A high thermal load may thus be handled in cases where the ceiling diffusers are placed at close pitch.

Equation (6) shows that x_s should be selected as short as possible, but comfort considerations restrict this to about $0.5 L - 0.75 L$.

The K_p value for the diffuser is not represented in the expression for maximum thermal load. A small K_p means that a high amount of air may be supplied at low velocities in the room, see equation (1), but it means also that the penetration length will be relatively short, see equation (3), and the effects will neutralize each other.

The results discussed in this chapter are also dependent on room geometry and distribution of thermal load, and only full scale experiments

such as the one shown in fig. 10 can give a fully quantitative description of the flow and the thermal comfort in the room, and the maximum thermal load which may be handled.

5. Control strategies based on room air distribution models

It is possible to develop some control strategies for the air conditioning system based on the models given in chapters 2 and 3 in cases where heat is removed from the room. Fig. 7 shows the allowed area for U_0 and T_0 . Determination of the maximum velocity in the occupied zone according to equation (4) gives the right boundary for the supply velocity shown in the figure. It is assumed that the penetration length x_s shall have a given minimum value and equation (3) shows that this corresponds to $U_0^2/\Delta T_0 > \text{const.}$, and this condition gives the left boundary on fig. 7.

Fig. 8 sketches a traditional dual duct system. Warm and cold air are supplied to the terminal units where the air is mixed according to the thermostatic control of the supply temperature. It is obvious that the system may have an additional energy consumption due to the mixing of cold and warm air in each terminal unit.

The supply velocity is constant and independent of the mixing ratio. Fig. 7 shows that the constant air volume (C.A.V.) gives a control strategy which will keep U_0 and T_0 for each room inside the allowed conditions.

It is possible to decrease the energy consumption in the system if the temperature T_0 in the cold duct is controlled from the room with the highest load in such a way that this temperature corresponds to the necessary supply temperature (for example, the upper room in fig. 8). The temperature in the ducts may also be controlled in zones according to the load distribution in the building.

Fig. 9 sketches a single duct system. The temperatures are controlled in the rooms by supplying a variable air volumen (V.A.V.) to each room. Fig. 7 shows that it is more difficult to fulfill the necessary conditions for U_0 and T_0 . The penetration length may be too short at low supply velocities, and this is especially the case when the load is high. This problem is often solved by using a diffuser which gives the jet a high penetration in all conditions, such as a diffuser with a variable supply area or a diffuser with additional directing jets. The single duct system is an energy efficient system if reheating of cold air is restricted to a minimum.

It is possible to control the temperature T_0 in the supply duct in such a way that all rooms are within the conditions allowed in fig. 7 if the load on each diffuser (ventilated section) varies in a similar manner during the day.

6. Prediction of recirculating flow in a room.

The velocity and temperature distribution in a room can be obtained by solving time-average differential equations for the flow by a computer-based numerical method, see reference /1/, /5/ and /6/. This method gives a complete background for the evaluation of thermal comfort as shown in the example in this chapter. It is a complicated method on a level with model and full scale experiments.

Results from the calculation method are given in fig. 10. The measurements shown are related to a geometry with $h/H = 0.0033$, $L/H = 1.87$ and made as a full scale experiment by Hestad /7/. Comparisons with calculations show that U_{Tm} is slightly over-predicted by approximately 10%, but the general velocity pattern is reproduced. The temperature

distribution is also represented satisfactorily in view of the strong influence of buoyancy in this flow.

7. Conclusions

A number of different models on the air distribution in rooms are introduced. The first model describes the importance of the dimensioning and location of the diffusers, and it is based on experiments. Another model gives the velocity decay in the wall jet region of the room and it is further extended to give the throw model, which is used in the traditional dimensioning procedure for supply openings. A model for the maximum velocity in the occupied zone at isothermal flow is given. This model is based on calculations and measurements.

The penetration length for a cold jet may be restricted when a large amount of heat is removed from the room by the ventilation system. The amount of heat which may be removed at constant penetration length is proportional to the cube of the maximum velocity in the occupied zone, and it is also shown that a large number of diffusers in a ventilated space increases the amount of heat which may be removed without affecting the thermal conditions.

Control strategies for dual duct and single duct systems are given, based on the room air distribution models.

The paper is concluded by mentioning a computer-based prediction method which gives the velocity and temperature distribution in the whole room, and this method gives the necessary parameters for a full description of the thermal conditions in the room.

References

1. Nielsen, P.V., Bestimmung der maximalen Luftgeschwindigkeit in der Aufenthaltszone eines klimatisierten Raumes, Heizung Lüftung/Klimatechnik Haustechnik, No. 9, 1980.
2. Hestad, T., Dimensioning of Supply Openings, Cold Draught (in Norwegian), Norsk VVS, No. 6, 1976.
3. Schwenke, H., Das Verhalten ebener horizontaler Zuluftstrahlen im begrenzten Raum, Diss. T.U. Dresden, 1973.
4. Skåret, E., Air Movement in Ventilated Rooms (in Norwegian), Inst. for VVS, NTH, Tapir, Trondheim, 1976.
5. Nielsen, P.V., A. Restivo and J.H. Whitelaw, The Velocity Characteristics of Ventilated Rooms, ASME J. Fluids Eng., Vol. 100, 1978, p. 291.
6. Nielsen, P.V., A. Restivo and J.H. Whitelaw, Buoyancy-affected flows in ventilated rooms, Numerical Heat Transfer, 2, 1979.
7. Hestad, T., Private communications, Farex Fabrikker A/S, Norway, 1974.

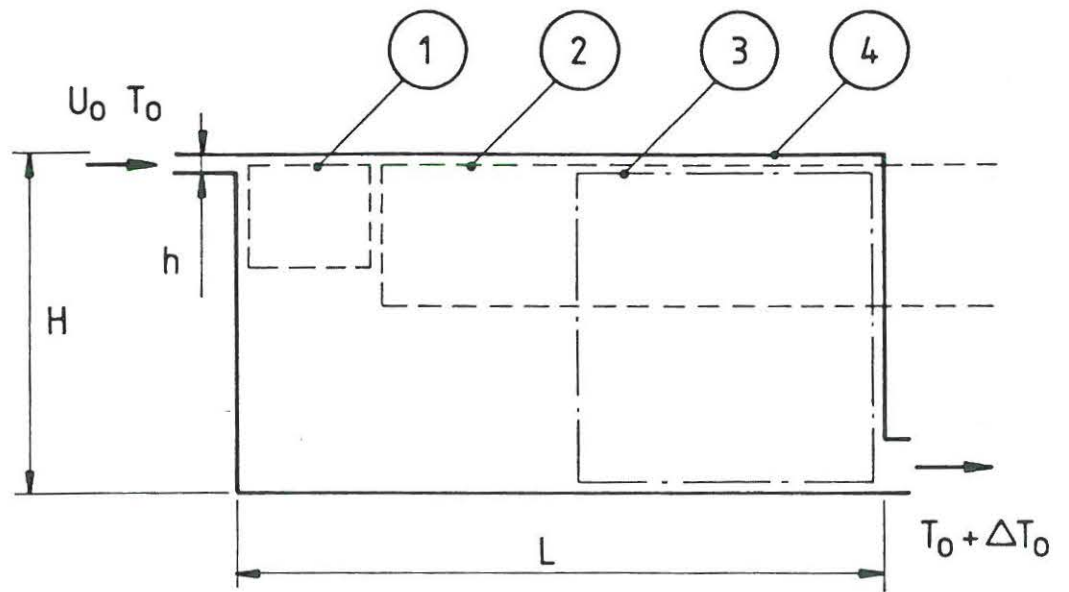

Fig. 1 Geometry of the room and location of the areas for the different room air distribution models.

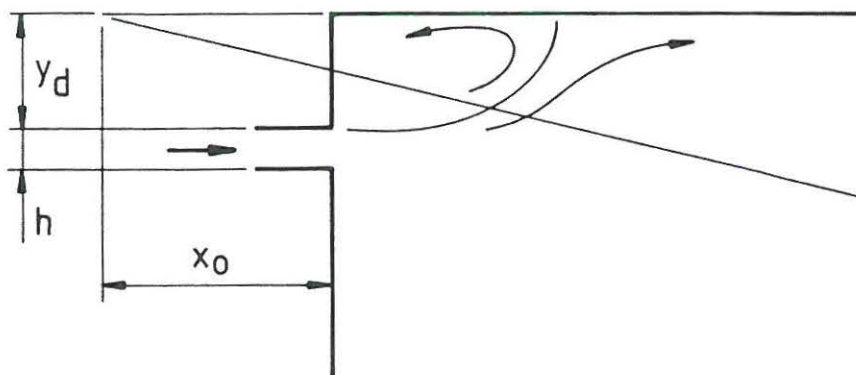

Fig. 2 Geometry of a linear slot diffuser placed at a distance from the ceiling.

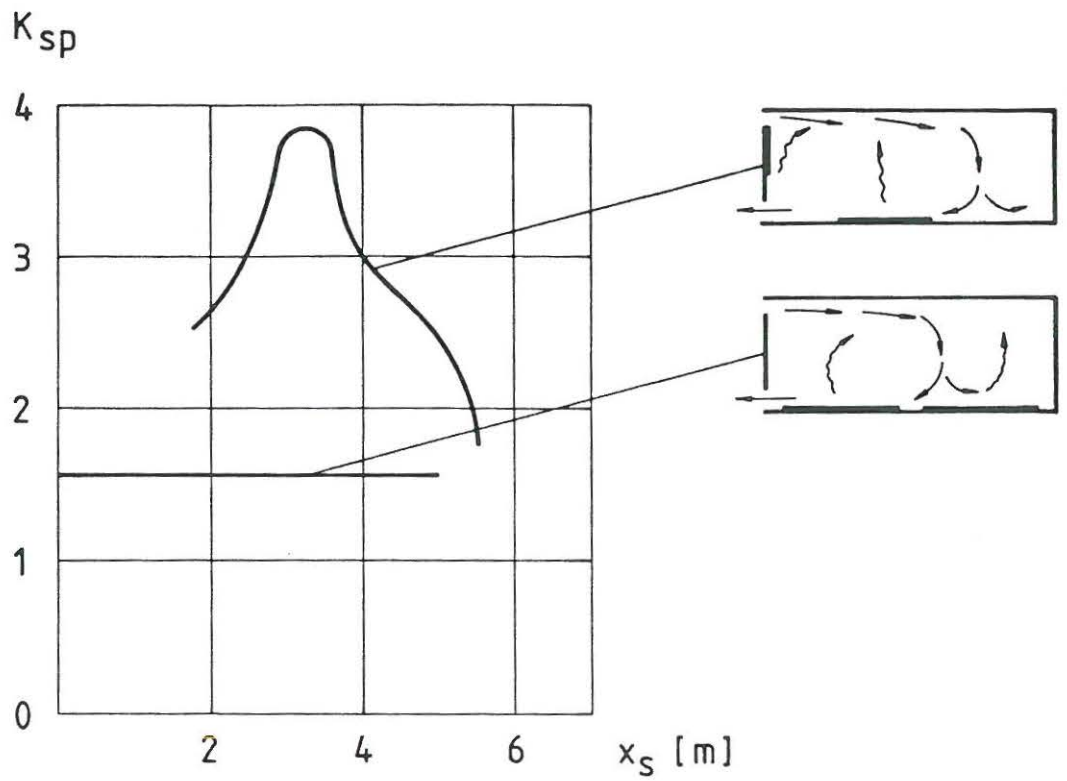

Fig. 3 K_{sp} , describing the influence from the location of the heat source as a function of penetration length $/2/$.

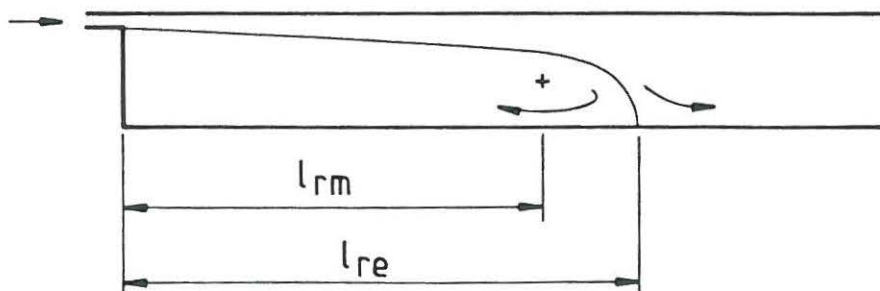

Fig. 4 Penetration length in a deep room at isothermal two-dimensional flow.

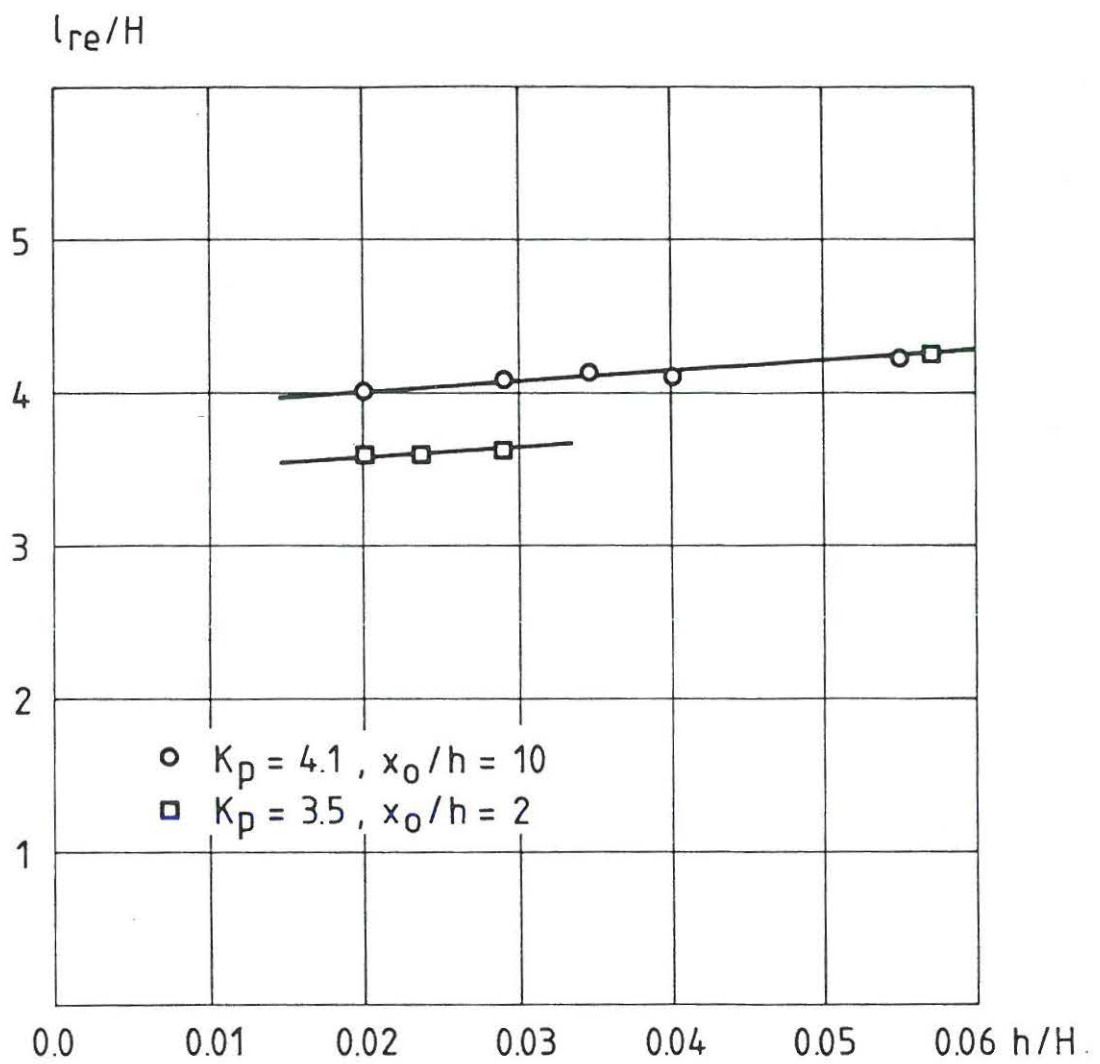

Fig. 5 Measurements of penetration length in a deep room at isothermal two-dimensional flow in the case of different supply openings.

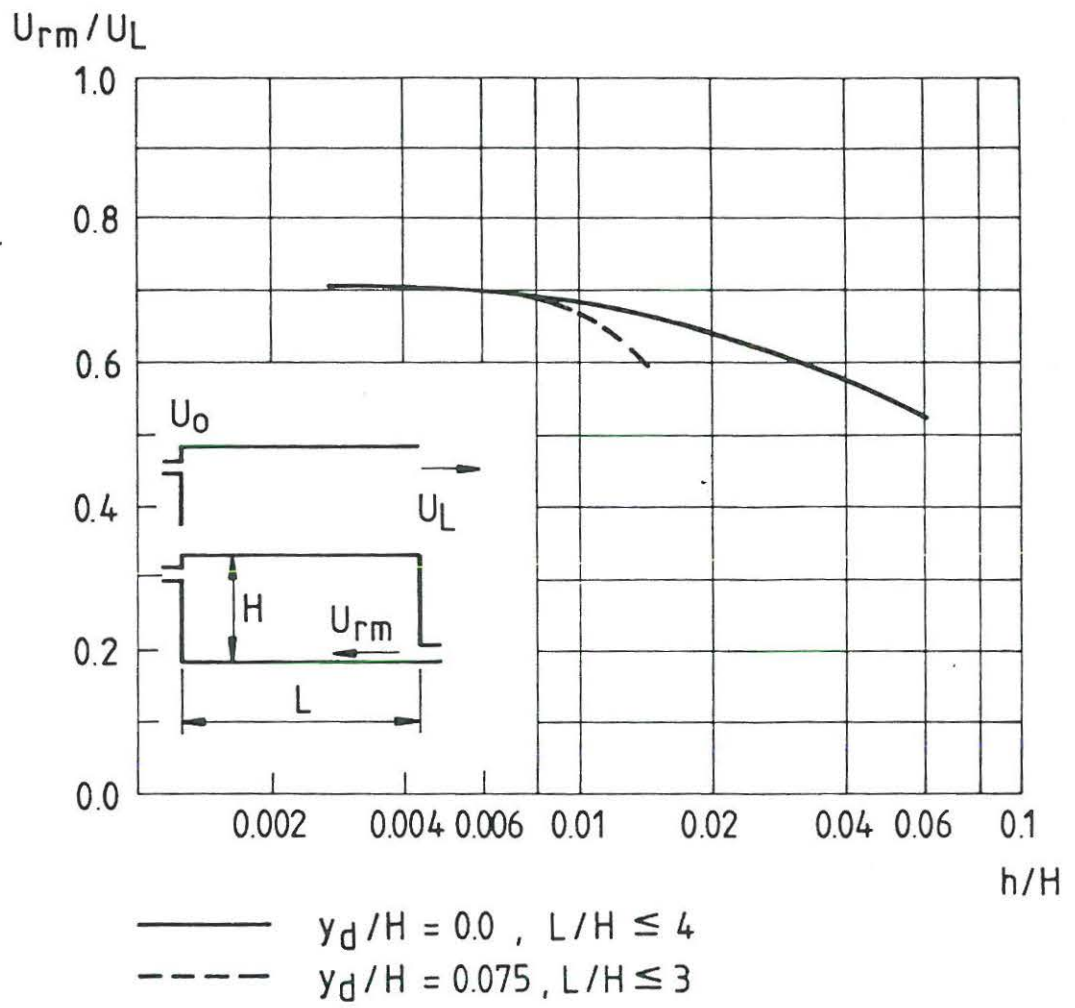

Fig. 6 U_{rm}/U_L in a room with linear slot diffuser and isothermal two-dimensional flow.

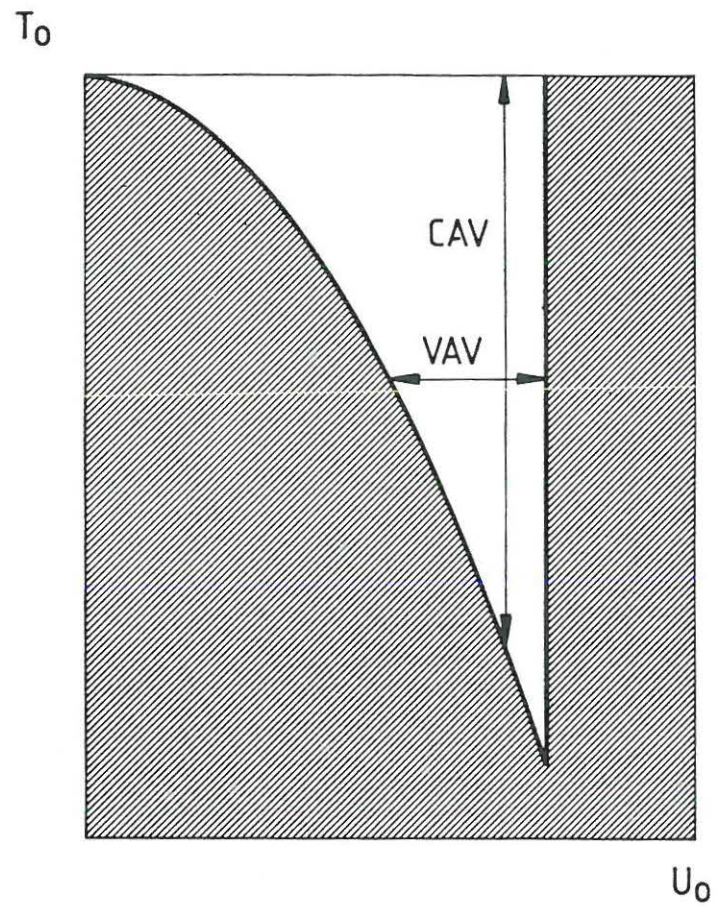

Fig. 7 Allowed area for supply temperature T_0 and supply velocity U_0 in a room.

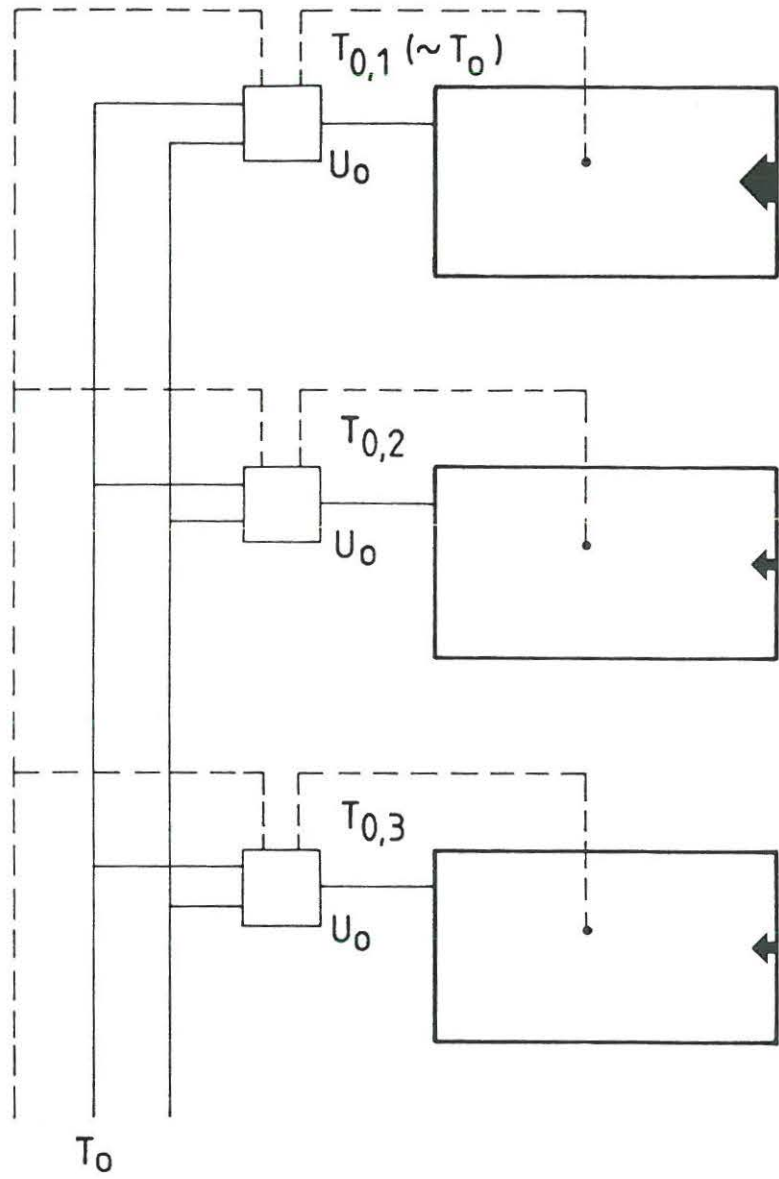

Fig. 8 Dual duct system. T_0 is the temperature in the cold duct and U_0 is a constant supply velocity to the rooms.

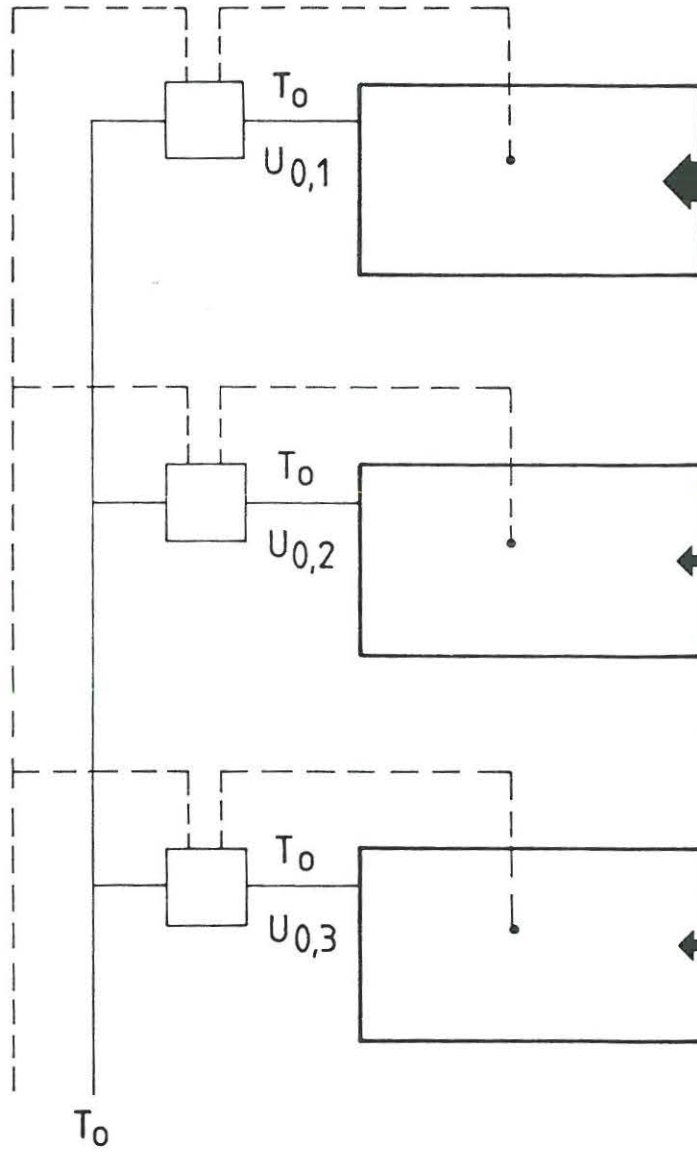
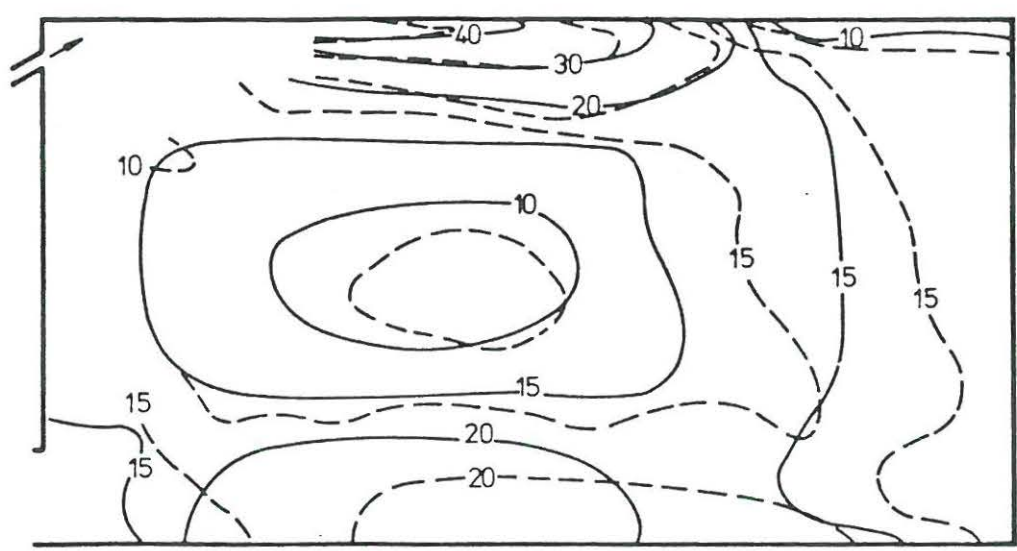
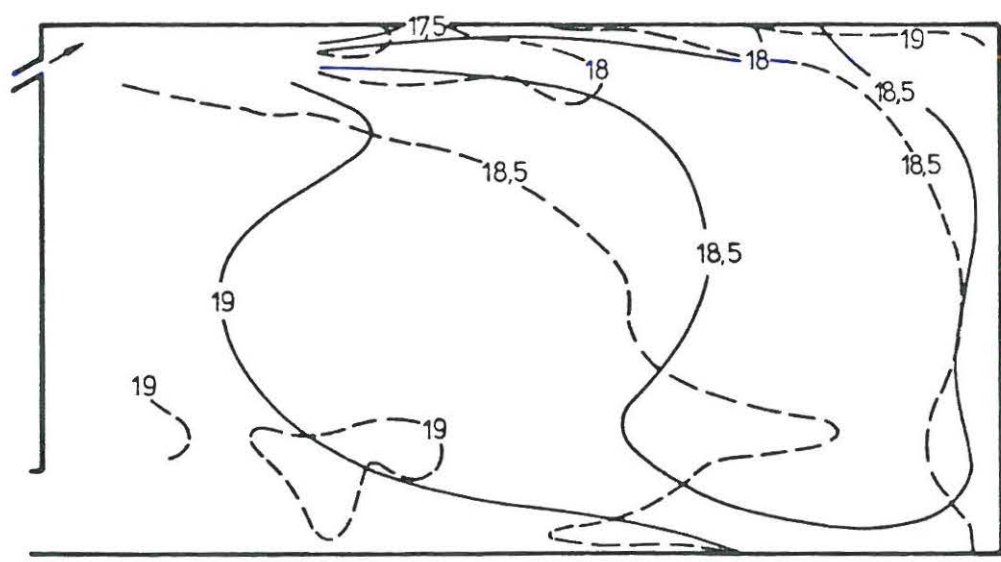

Fig. 9 Single duct system. T_0 is the supply temperature and $U_{0,1}$, $U_{0,2}$ and $U_{0,3}$ are the different supply velocities to the rooms.



Velocity distribution (cm/s)

— Predictions - - - Experiments



Temperature distribution (°C)

Fig. 10 Full scale experiments and predictions of the flow in a room. Heat source on a part of the floor area .