



Aalborg Universitet

AALBORG UNIVERSITY
DENMARK

Control and experimental characterization of a methanol reformer for a 350 W high temperature polymer electrolyte membrane fuel cell system

Andreasen, Søren Juhl; Kær, Søren Knudsen; Sahlin, Simon Lennart

Published in:
International Journal of Hydrogen Energy

DOI (link to publication from Publisher):
[10.1016/j.ijhydene.2012.09.032](https://doi.org/10.1016/j.ijhydene.2012.09.032)

Publication date:
2013

Document Version
Accepted author manuscript, peer reviewed version

[Link to publication from Aalborg University](#)

Citation for published version (APA):
Andreasen, S. J., Kær, S. K., & Sahlin, S. L. (2013). Control and experimental characterization of a methanol reformer for a 350 W high temperature polymer electrolyte membrane fuel cell system. *International Journal of Hydrogen Energy*, 38(3), 1676-1684. <https://doi.org/10.1016/j.ijhydene.2012.09.032>

General rights

Copyright and moral rights for the publications made accessible in the public portal are retained by the authors and/or other copyright owners and it is a condition of accessing publications that users recognise and abide by the legal requirements associated with these rights.

- ? Users may download and print one copy of any publication from the public portal for the purpose of private study or research.
- ? You may not further distribute the material or use it for any profit-making activity or commercial gain
- ? You may freely distribute the URL identifying the publication in the public portal ?

Take down policy

If you believe that this document breaches copyright please contact us at vbn@aub.aau.dk providing details, and we will remove access to the work immediately and investigate your claim.

Provided for non-commercial research and education use.
Not for reproduction, distribution or commercial use.

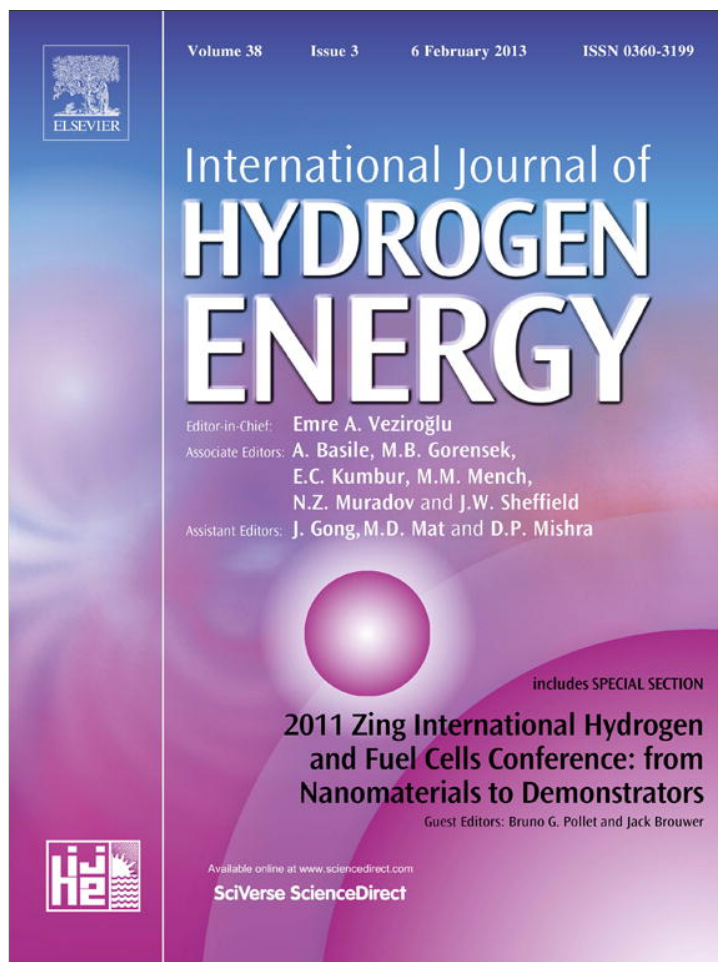

This article appeared in a journal published by Elsevier. The attached copy is furnished to the author for internal non-commercial research and education use, including for instruction at the authors institution and sharing with colleagues.

Other uses, including reproduction and distribution, or selling or licensing copies, or posting to personal, institutional or third party websites are prohibited.

In most cases authors are permitted to post their version of the article (e.g. in Word or Tex form) to their personal website or institutional repository. Authors requiring further information regarding Elsevier's archiving and manuscript policies are encouraged to visit:

<http://www.elsevier.com/copyright>

Available online at www.sciencedirect.com

SciVerse ScienceDirect

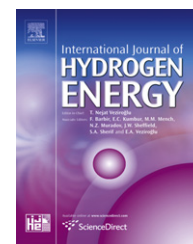
journal homepage: www.elsevier.com/locate/ije

Control and experimental characterization of a methanol reformer for a 350 W high temperature polymer electrolyte membrane fuel cell system

Søren Juhl Andreasen*, Søren Knudsen Kær, Simon Sahlin

Department of Energy Technology, Aalborg University, Pontoppidanstræde 101, DK-9220 Aalborg East, Denmark

ARTICLE INFO

Article history:

Received 31 March 2012
 Received in revised form
 5 September 2012
 Accepted 5 September 2012
 Available online 16 October 2012

Keywords:

Methanol
 Reformer
 Control
 PBI
 HTPEM
 Fuel cell

ABSTRACT

This work presents a control strategy for controlling the methanol reformer temperature of a 350 W high temperature polymer electrolyte membrane fuel cell system, by using a cascade control structure for reliable system operation. The primary states affecting the methanol catalyst bed temperature is the water and methanol mixture fuel flow and the burner fuel/air ratio and combined flow. An experimental setup is presented capable of testing the methanol reformer used in the Serenergy H3 350 Mobile Battery Charger; a high temperature polymer electrolyte membrane (HTPEM) fuel cell system. The experimental system consists of a fuel evaporator utilizing the high temperature waste gas from the cathode air cooled 45 cell HTPEM fuel cell stack. The fuel cells used are BASF P1000 MEAs which use phosphoric acid doped polybenzimidazole membranes. The resulting reformat gas output of the reformer system is shown at different reformer temperatures and fuel flows, using the implemented reformer control strategy. The gas quality of the output reformat gas is of HTPEM grade quality, and sufficient for supporting efficient and reliable HTPEM fuel cell operation with CO concentrations of around 1% at the nominal reformer operating temperatures. As expected increasing temperatures also increase the dry gas CO content of the reformat gas and decreases the methanol slip. The hydrogen content of the gas was measured at around 73% with 25% CO₂.

Copyright © 2012, Hydrogen Energy Publications, LLC. Published by Elsevier Ltd. All rights reserved.

1. Introduction

High temperature PEM fuel cells normally operate at 160–180 °C, which is too high a temperature to support the use of Nafion-based membranes, that are dependent on the presence of liquid water for proton conduction. A typical polymer used in HTPEM fuel cells is polybenzimidazole (PBI), doped with phosphoric acid to facilitate proton conduction. Some challenges are involved with operation at these high temperatures, including increased degradation and corrosion mechanisms [1–5], higher requirements for the materials and

components used and longer system start-up times [6,7]. The increased operating temperatures of these fuel cells, have the advantages of reducing the challenges involved with water management within the fuel cells and systems, less complex systems and cooling requirements due to the increased temperatures [8–11], and significant improvements toward the tolerances of CO in the anode gas. Using hydrogen containing CO, decreases the steady-state as well as dynamic electrical performance of the fuel cell, but stable operation is still possible with concentrations up to 3% [12]. The robustness of the HTPEM fuel cell, and the increased tolerance to CO

* Corresponding author. Tel.: +45 99 40 92 90.

E-mail address: sja@et.aau.dk (S.J. Andreasen).

also enables the use of reformer systems with less hydrogen cleaning steps and requirements for hydrogen purity reducing the complexity of the reformer systems. The advantages of using reformers are the capabilities of using non-hydrogen fuels with already established and wide spread production facilities and with good potential for being derived from biomass or other renewable sources. Using liquid fuels such as methanol also removes the high volume demands of compressed hydrogen storages, reduces refueling time, and enables the use of existing fuel distribution systems. Different studies exist showing the advantages of using methanol reformer systems [13–15] and the work presented in the following deals with the specific control of a methanol reformer as part of a HTPEM fuel cell system.

HTPEM fuel cell systems are usable both as pure fuel cell systems in many applications, but also in hybrid electrical systems as auxiliary power supplies, uninterruptible power supply, and range extenders for electrical vehicles. The Serenergy H3 350 is a mobile battery charger capable of supplying controlled off-grid power, typically for charging 24 V lead acid battery packs. Using fuel cells in combination with batteries offers advantageous electrical systems where increased energy demand is required. A picture of the module is shown in Fig. 1.

Proper control of the reformer temperature during different state changes in temperature and fuel flow is critical when analyzing the performance of the reformer system. With a properly controlled system, much knowledge can be gained about both steady-state performance as well as the dynamic capabilities of the reformer system. These initial experiments of the system primarily concern measurements conducted without the presence of the fuel cell, which is instead replaced by hardware emulating fuel cell performance, such that reformer performance can be evaluated isolated from the operating conditions of the fuel cell stack.

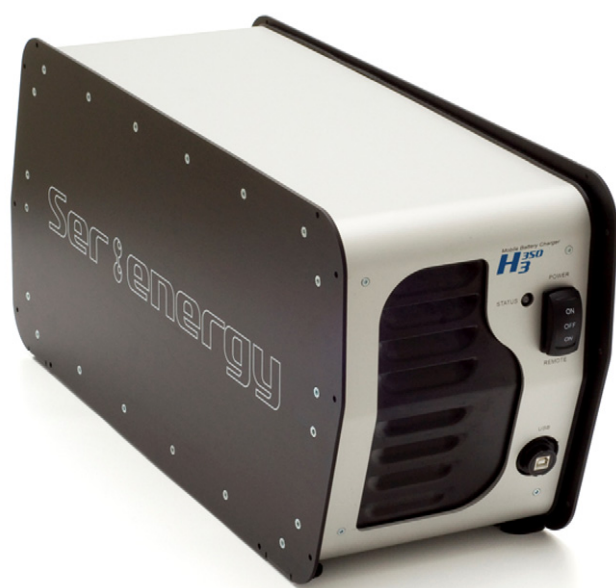

Fig. 1 – The Serenus H3-350 mobile battery charger by Serenergy. A 350 W integrated HTPEM fuel cell system fueled by a methanol reformer.

The initial experiments of the isolated methanol reformer system, are conducted in order to test and verify the proposed control strategy for the burner and reformer temperature, and in order to enable experimental characterization of important system states, such as CO, methanol slip and the transient capabilities of the system. Detailed knowledge of these different system features are important in order to avoid various critical system events that potentially can reduce system lifetime.

2. Experimental setup

The experimental system examined is shown in Fig. 2. In this setup, the reformer and evaporator have been removed from the integrated system, and an air pre-heater connected with a Bürkert 8711 mass flow controlled air system is able to replace the hot cathode exhaust air from the cathode air cooled stack. Heating of the incoming air is done by using a 3.3 kW LHS System – Type 20L14.5 A which is able to preheat the incoming air.

A methanol and water mixture with a steam-to-carbon (SC) ratio of 1.5 is pumped using a ESX 40E membrane pump through the evaporator, where it is heated, evaporated and superheated. Afterward the gaseous flow enters the methanol reformer where it is converted into hydrogen rich gas, also containing traces of CO, CO₂, water and residual methanol depending on the temperature and space velocity. Both reformer and evaporator are equipped with electrical heating elements for system start-up and heat during operation is supplied by adding hydrogen and air from two separate Bürkert 8626 mass flow controllers.

The reforming process is dominated by the following chemical reactions:

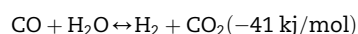
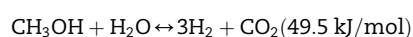
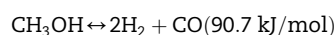

In order to evaluate the performance of the reformer, a set of Siemens Gas Analyzing modules: Fidamat, Ultramat, Calomat units are used.

The data acquisition, controller implementation and interface between the different system components is carried out using a National Instruments based Compact RIO 9012 system, with various I/O modules, which handles all start-up, operation and shutdown procedures. An automation routine has been implemented for varying the different temperatures and flows used in each experiment, and this system also monitors and ensures that proper measures are taken in case of critical system states. The evaporator and reformer used in the work presented here are from version 1.65 of the Serenergy H3-350.

2.1. Measurement sequence

To examine the different effects that varying temperature, current and gas concentrations have on the output gas

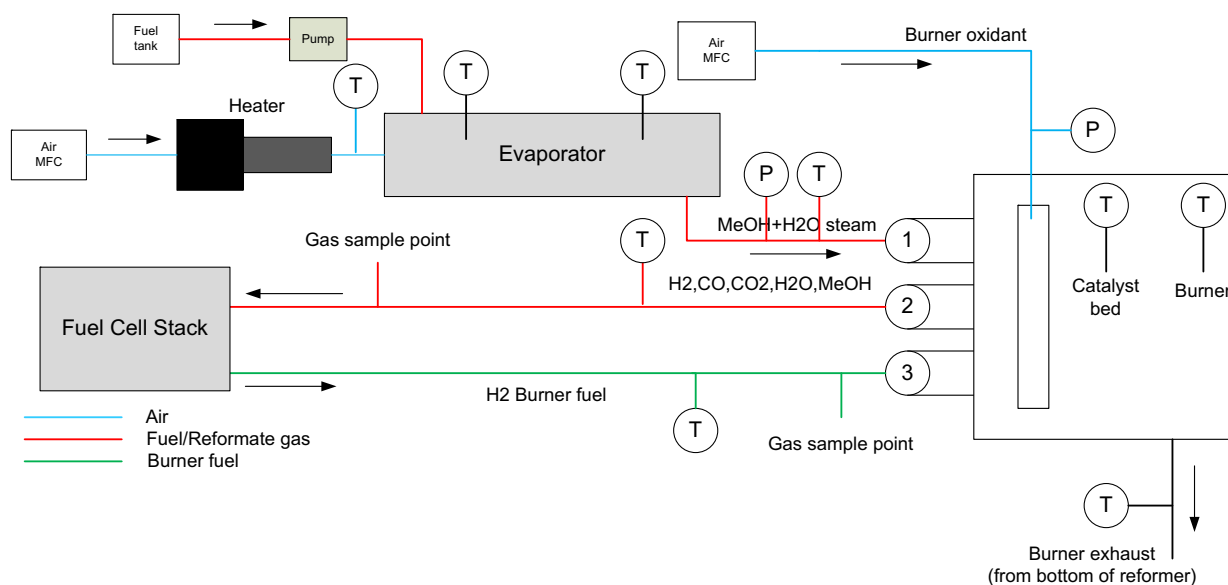

Fig. 2 – Schematic of the system setup including the primary components and connections.

concentrations from the system, a series of different measurements are conducted. The states, which are varied in the measurements presented in this work, are the following:

- Reformer operating temperature, 240–300 °C in positive steps of 20 °C
- Fuel pump flow, 200–400 mL/h in positive steps of 100 mL/h

Changing these different desired operating points, will give a detailed view of the methanol reformer performance in different steady-state operating points, but also enable a test of the controller performance of the implemented methanol temperature cascade control.

3. Reformer temperature control

The control of the reformer temperature is carried out using the strategy shown in Fig. 3, where a block diagram of the control structure is depicted.

Two negative feedback control loops are used, a fast inner loop controlling the burner temperature T_{Burner} , and an outer slow loop that controls the reformer temperature T_{Reformer} . The burner temperature is controlled by manipulating the volume air flow to the burner $\dot{q}_{\text{air,burner}}$. Under all the shown experiments, the burner hydrogen flow $\dot{q}_{\text{H}_2,\text{burner}}$ is set at a fixed value of 4.5 L/min, and the air-to-hydrogen ratio is limited to a minimum value of 8 in order to avoid possible

flashback, and critically high temperatures in the reformer. In this way, the burner is effectively controlled by adjusting the burner temperature according to the changing conditions of the reformation process due to either changing reformer set point temperature $T_{\text{Setpoint, Reformer}}$ or changes in the methanol/water fuel flow \dot{q}_{Fuel} . In the cases shown here both C_{Burner} and C_{Reformer} are using simple PI control algorithms with anti-windup.

The primary control parameters used during these measurements are shown in Table 1.

4. Experimental results

The reformer system experiments and verification of the controller strategy is carried out using an automated test sequence where, in this case, reformer temperatures and fuel flows are varied over a range of possible operating conditions. For each operating point, when the system states have been within the desired values for a specified number of minutes, the operating conditions are changed, and the controller behavior and output gas concentrations can be examined.

4.1. System flows

During the course of the measurement sequence, the input flows to the system are presented in Fig. 4.

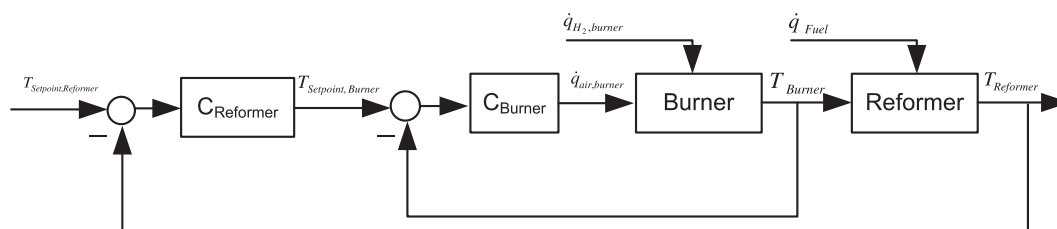

Fig. 3 – Block diagram of the chosen cascade control strategy of the reformer and burner temperature.

Table 1 – Main control parameters of burner and reformer temperature controllers.

Control parameters	C_{Burner}	C_{Reformer}
Proportional gain K_p	-2 L/min/ $^{\circ}$ C	6 [-]
Integral time T_i	12 s	480 s

In this study, the fuel cell stack, and the dynamics of the fuel cell stack is not under consideration, for these reasons, the emulated cathode air flow from the fuel cell air exhaust over the evaporator, is constantly set to 120 L/min. In a running system with a fuel cell stack, this airflow, and temperature will also be a critical parameter and additional variable that needs to be taken into consideration. The airflow of an air cooled stack can be controlled in different ways depending on whether it has separate air cooling channels, or uses increased cathode stoichiometries as cooling [6,11,16]. In the full H3 350 system with the included fuel cell stack, the hydrogen supplied to the burner will be the anode exhaust of the fuel cell, which means that this flow is directly linked to the reformer performance, evaporator efficiency, anode

stoichiometry and current load on the fuel cell stack. The constant value of 4.5 L/min is chosen in order to ensure the reformer reaching high temperatures even at the highest fuel flows. An optimization of this burner hydrogen flow is possible for future studies, ensuring maximum efficiency. In Fig. 4 it is seen that during the experiments the flow goes through a repeating sequence, where it steps through the desired flows of 200, 300 and 400 mL/h. Lower flows are possible, but the chosen measurement set is within the sampling range of the gas analysis equipment and adequate for this study that focus on verifying the functionality of the reformer temperature control strategy. The shown input flows also include the burner air flow, i.e. the flow manipulated in order to control the burner and reformer temperature. The distinct downward spikes in the air flow is the combined response of the controllers to the step changes in temperature.

4.2. System temperatures

In Fig. 5 the system temperatures during the measurement sequence are seen; most importantly in this study, the

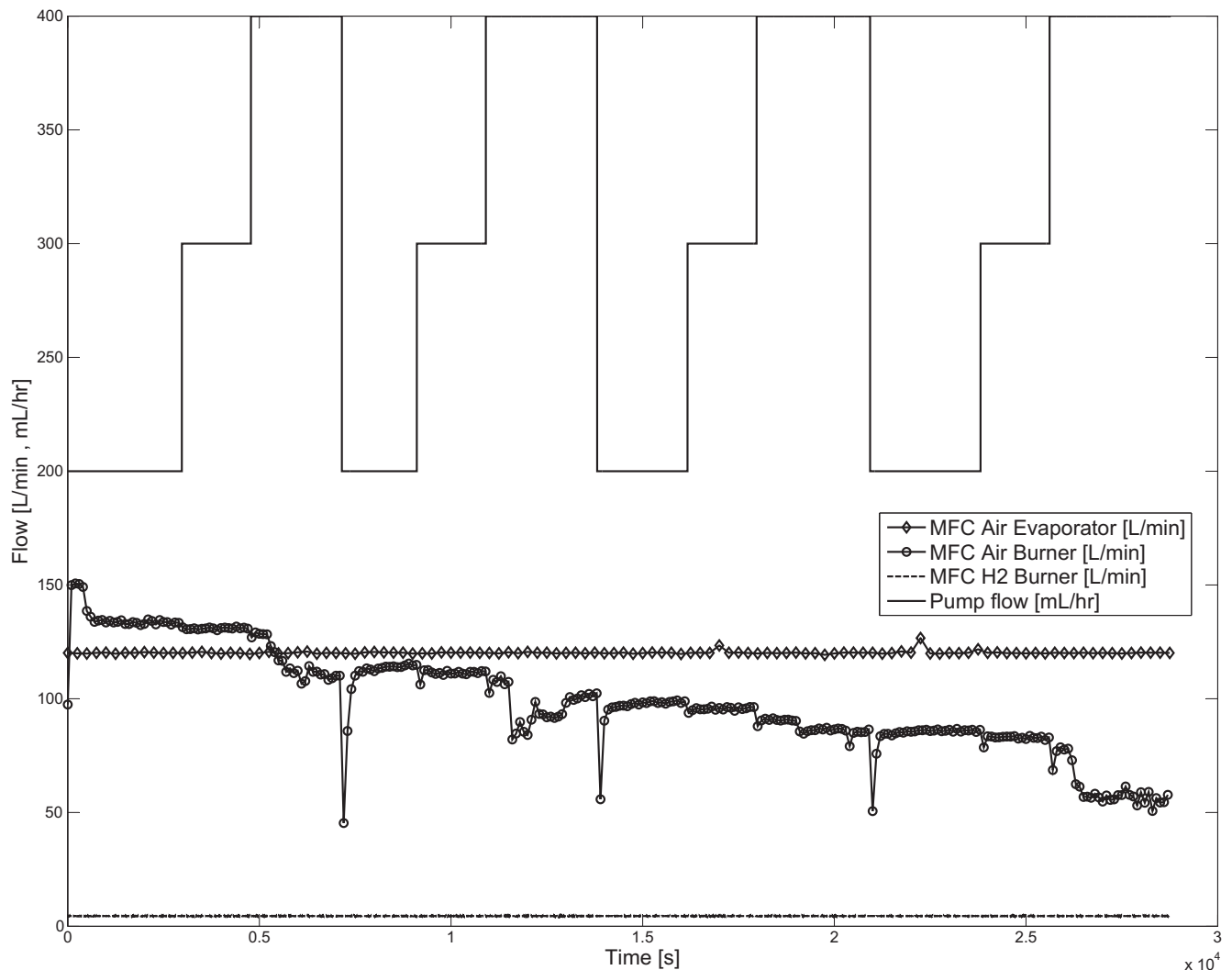

Fig. 4 – Graph of the different system input flows during experimental study using the measurement sequence described.

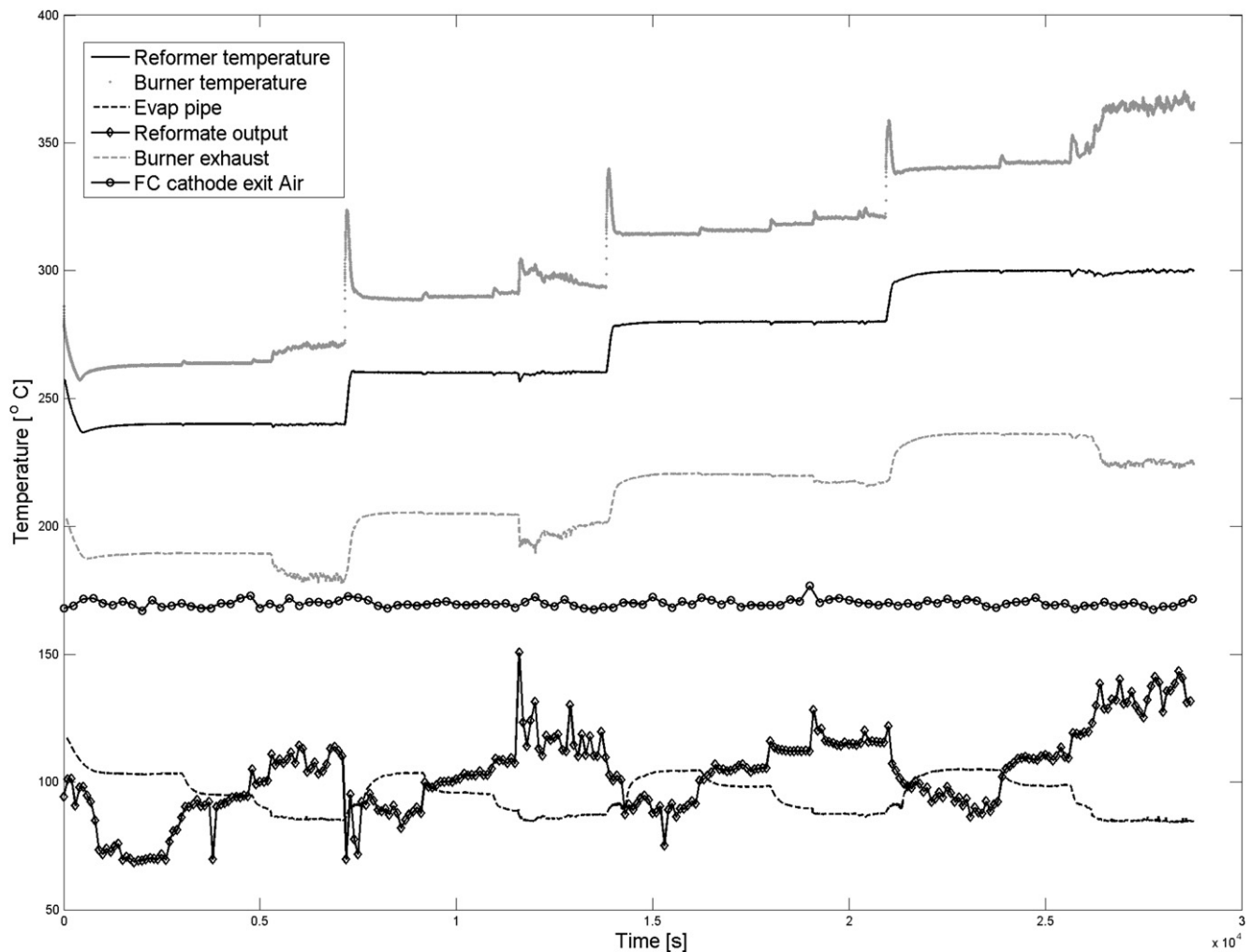

Fig. 5 – Graph of the different system temperatures during use of the described measurement sequence.

reformer temperature is seen as steady step wise changes, were within each temperature, different pump flows are used without severe over- or undershoots in the reformer temperature.

The burner temperature shows a more dramatic behavior due to the faster controller action, and the more rapid changes in this inner control loop. The small controller responses experienced during changes in pump flow are more visible but within acceptable limits. The burner exhaust temperature, which is measured near the outlet of the burner, is seen as steady with a tendency of a slight decrease at the highest pump flows used under each measured reformer temperature. This decrease during high pump flows can be removed by extending the controllability of the burner, which would be required for the full system, and not run with a fixed hydrogen flow as done in this study. The reason for the much lower temperature of the out coming reformate gas, is the circulation of the hot combusted burner flow through various heat exchange areas in the reformer for increased heat transfer to the catalyst bed.

The constant fuel cell anode exit temperature is, as mentioned above, emulated by a mass flow controller and

a controlled heater. The fixed temperature of 170 °C matches the expected average fuel cell stack exhaust temperature of the real system.

As seen in Fig. 5, the reformate output temperature shows a more unstable behavior, and increases in temperature when pump flow increases. The temperature increases are synchronous with the pump flow, and is mainly due to the increased heat transfer, because additional burner heat also is introduced by the control loop, by decreasing the air flow to the burner. Also the unstable behavior of the measured temperatures could be due to the placement of the temperature sensor, which is placed slightly outside in the exit pipe of the reformer near the gas analyzer and exhaust pipe interface. The unstable behavior is due to the presence of water and methanol droplets depositing on the thermocouple placed in uninsulated pipes.

The evaporator temperature shows slightly dropping temperatures with increasing pump flows, due to the fact that constant heat is supplied to the evaporator, an amount of heat that matches and ensures satisfactory heating and evaporation of the fuel flow, during the different flow changes in the measurement sequence. Further analysis should be made on

proper evaporator control in the full system, where the heat supplied, and the equilibrium of the liquid and steam phase within the evaporator greatly depends on the fuel cell stack performance.

4.3. Reformer output concentrations

Fig. 6 shows a plot of the measured reformer output concentrations, the hydrogen content during all operating conditions being a value of 70.1–73.6% during all of the measured pump flows and temperatures. The concentrations of CO_2 are in a similar way only visible as small changes due to the relatively small changes in CO concentrations as shown in Table 2 at around 25% during all measurements.

The most dramatic and important changes in gas concentrations are of course CO and methanol concentrations. In Fig. 2 the raw data from the analyzer is plotted, showing increasing CO content when increasing the reformer temperature, and decreasing methanol content during the increase of reformer temperatures. As expected, increasing pump flows also yields higher CO content and lower methanol concentrations due to the kinetics of the used catalyst. Table 2 summarizes the averaged measured results at each of the three flows used for every reformer set point temperature.

4.4. Discussion

A closer view of the temperature behavior during the temperature steps from 260 °C to 280 °C, and from 280 °C to 300 °C can be seen in Fig. 7. This more detailed view also contains information of the set points for each of the controllers, such that controller performance can be evaluated both during reformer temperature changes and positive steps in the fuel flow. During normal operation, the reformer set point temperature will usually be fixed, and the controller operation will require the controller to primarily be robust against changes in the fuel flow.

As seen the reformer controller quickly changes the burner set point during temperature steps. The reformer temperature settling time is approximately 5 min in the different transitions. During these transitions, the burner set point temperature is increased in order to initiate an additional transfer of heat to the catalyst bed. A saturation limit of 400 °C is added in the burner controller anti-windup, in order to avoid unwanted high temperatures in the burner, that potentially could lead to severe damage to the burner. The changes in fuel flow also show small increases in burner set point temperature due to the resulting fall in reformer temperature occurring under these positive steps in fuel flows. Using the before mentioned

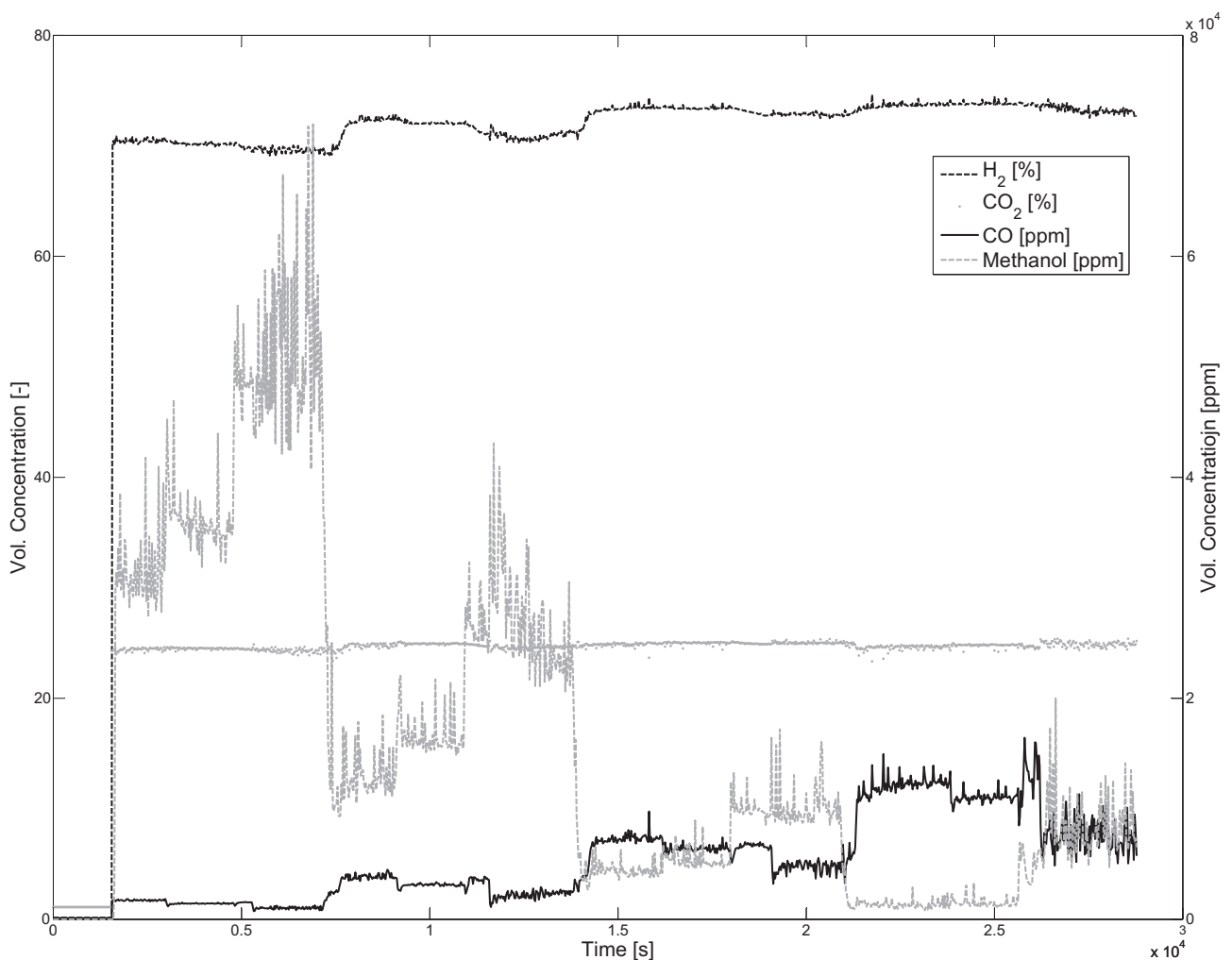

Fig. 6 – Graph of the different system output gas concentrations during measured sequence.

Table 2 – Summary of the averaged gas concentrations during at the different flows and temperature of the experiments.

	\dot{q}_{fuel} [mL/h]	H ₂	CO ₂	CO			CH ₃ OH		
		All flows	All flows	200	300	400	200	300	400
T_{reformer}	240 °C	≈ 70.1%	≈ 24.4%	0.172%	0.142%	0.111%	3.178%	3.64%	5.08%
	260 °C	≈ 71.6%	≈ 24.8%	0.365%	0.311%	0.251%	1.25%	1.66%	2.78%
	280 °C	≈ 73.2%	≈ 24.9%	0.710%	0.640%	0.541%	0.435%	0.533%	0.998%
	300 °C	≈ 73.6%	≈ 24.8%	1.16%	1.11%	0.811%	0.131%	0.142%	0.791%

control parameters, the maximum changes in reformer temperature measured during flow changes is around 5 °C, which is usually found during steps to the highest flows. It should be noted that further quantification of the effects of even small temperature changes during transients should be examined in order to properly determine specific demands for controller performance. According to Table 2 even small changes in reformer temperature can have a significant impact on the well-known reduced performance effects of increased CO concentrations in the hydrogen gas. During positive steps in the fuel flow, the reformer temperature will experience a slight decrease before reaching the desired set point temperature, negative fuel flow steps will have an opposite effect, i.e. increased temperatures and hereby CO

concentrations. Analyzing the dynamics of these effects will increase the understanding of how these systems are controlled properly.

When expanding the system analysis to also include the fuel cell stack, and components, the complexity of the system, and the control of it, becomes more complex, also increasing the importance of characterizing at which minimum fuel cell current the stack is generating enough heat retain its capabilities of evaporating the water/methanol mixture for stable system performance. Further challenges exist in determining the prediction and proper choice of anode stoichiometry to ensure that no unnecessary combustion of hydrogen takes place and that the fuel cell stack avoids the degrading effects of anode starvation. When using the presented burner control

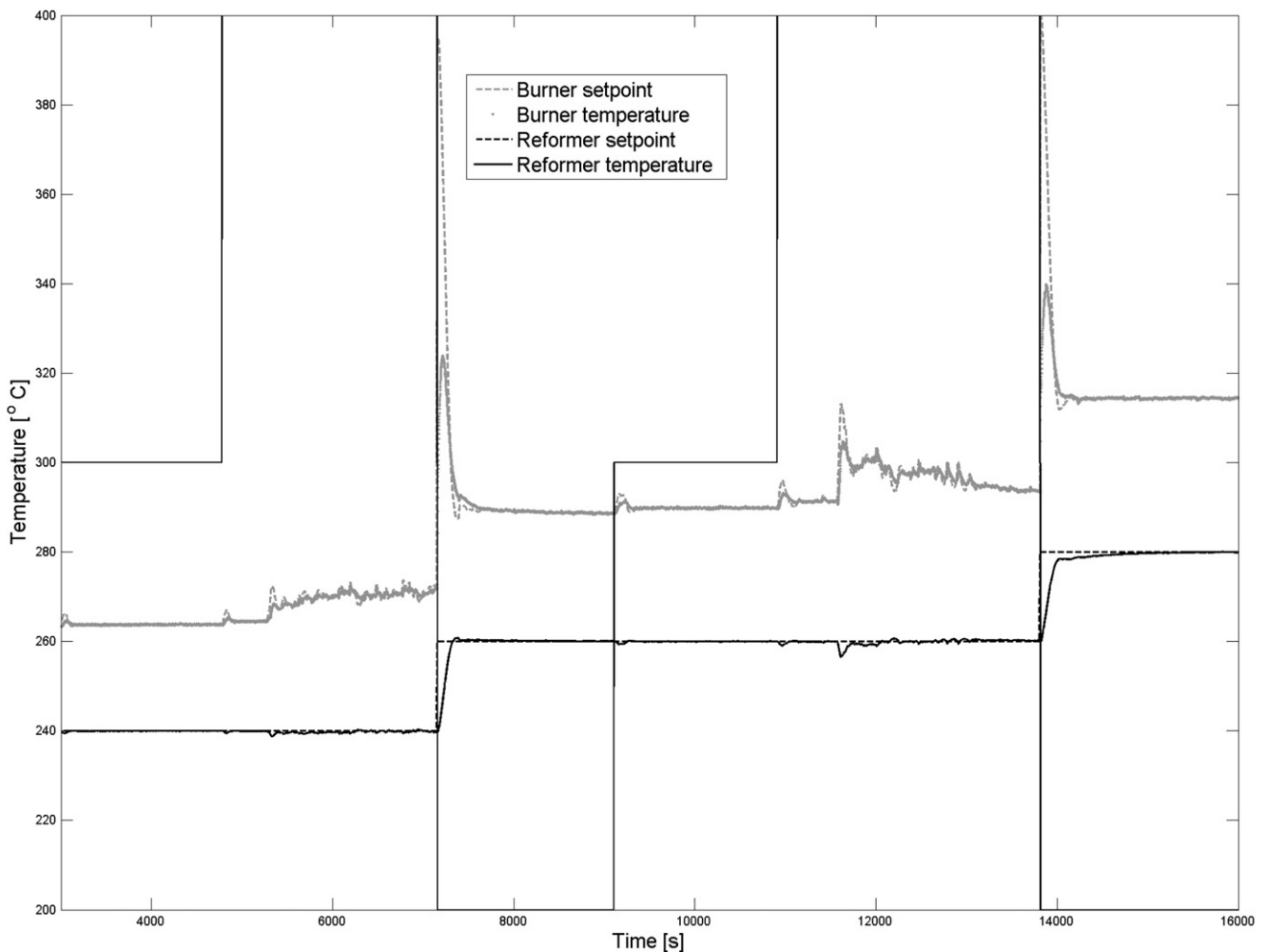

Fig. 7 – Detailed view of system burner and reformer temperature during temperature and flow transitions.

strategy, the burner controllers reaction to high hydrogen flows, would be to increase the burner air flow, in order to avoid high temperatures, removing excess heat. The best way of avoiding this is by properly ensuring that the fuel pump flow is properly matched to the hydrogen demand of the fuel cell stack, which requires complex insight into the states of many different parts of the fuel cell system.

5. Conclusions

Fuel cell systems are advanced electrochemical devices, that efficiently convert the chemical energy available in a gas or liquid into electricity and heat. High temperature PEM fuel cells offer many advantages when it comes to using liquid fuel alternatives to hydrogen. The reformer system topologies possible when using HTPEM fuel cells are of simpler design than similar reformer systems for Nafion-based low temperature PEM fuel cells due to the increased tolerance of for example CO. Even though system configurations are simpler, they still behave highly non-linear, and more work is required in order to design adaptive control systems that ensure efficient and reliable performance.

This work has shown the development of a cascade control strategy for a high temperature PEM fuel cell system fueled by methanol via steam reforming. An experimental setup has been developed and presented for testing a methanol reformer unit capable of supporting the production of 350 W of electrical power to a high temperature PEM fuel cell stack. A series of tests were conducted on the methanol reformer used in the Serenergy H3-350 (version 1.65) mobile battery charger, where the effects of changing space velocities and burner/reformer temperatures were examined. The gas quality of the output reformat gas is of HTPEM grade quality, and sufficient for supporting efficient and reliable HTPEM fuel cell operation with CO concentrations of around 1% at the nominal reformer operating temperatures. As expected increasing temperatures also increase the CO content of the reformat gas and decreases the methanol slip. The hydrogen content of the gas was measured at around 73% with 25% CO₂.

The proposed cascade control structure was developed and implemented in order to control the reformer temperature. An inner control loop ensuring proper and safe control of the burner air/fuel mixing and temperature was implemented, and an outer loop controlling the final reformer temperature was used to vary the burner temperature to obtain the desired reference reformer temperature. The controller was tested successfully during both changes in reformer set point temperature, and step changes in the fuel flow showing safe and reliable performance.

6. Future work

The work presented has demonstrated a detailed experimental study of the methanol reformer used in the Serenergy H3-350 mobile battery charger, enabling further studies of efficient control and modeling of the transient capabilities of such systems. Future work will include the addition of the fuel cell stack to system tests, and the inclusion of the increased

complexity on system control capabilities of such systems. Also further work is needed in order to fully characterize the different time constants present in such systems for properly determining the limitations on load current changing capabilities [A/s], i.e. the allowable rate at which the fuel cell current can be ramped up or down in order to avoid critically high burner/reformer temperatures and anode starvation. Furthermore an optimization of system efficiency by minimizing the fuel cell anode stoichiometry and hereby the burner hydrogen flow could prove important in order to ensure high system efficiency. Additional considerations could also further describe proper control strategies for choosing minimum system power outputs, which could have significant impact on the choice of battery charging strategy for hybrid fuel cell/battery applications.

Most importantly the prediction of the critical internal states of these systems should be in focus, enabling the use of observers or other means of model based controllers to robustly control these systems through a broad range of operating conditions and during their entire lifetime.

Acknowledgments

We gratefully acknowledge the financial support from the Danish Energy Technology Development and Demonstration program (EUDP) under the HI-EPS grant 64009-0218.

REFERENCES

- [1] Cheng Xuan, Shi Zheng, Glass Nancy, Zhang Lu, Zhang JiuJun, Song Datong, et al. A review of PEM hydrogen fuel cell contamination: impacts, mechanisms, and mitigation. *Journal of Power Sources* 2007;165:739–56.
- [2] Schmidt Thomas J. Durability and degradation in high-temperature polymer electrolyte fuel cells. *ECS Transactions* 2006;1:19–31.
- [3] Zhang Shengsheng, Yuan Xiaozi, Wang Haijiang, Mérida Walter, Zhu Hong, Shen Jun, et al. A review of accelerated stress tests of MEA durability in PEM fuel cells. *International Journal of Hydrogen Energy* 2009;34:388–404.
- [4] Schmidt Thomas J. Durability and degradation in high-temperature reformed hydrogen PEFCs. *ECS Transactions* 2006;3:861–9.
- [5] Zhai Yunfeng, Zhang Huamin, Liu Gang, Hu Jingwei, Yi Baolian. Degradation study on mea in H₃PO₄/PBI high-temperature PEMFC life test. *Journal of The Electrochemical Society* 2007;154:B72–6.
- [6] Andreasen Søren Juhl, Kær Søren Knudsen. Modelling and evaluation of heating strategies for high temperature polymer electrolyte membrane fuel cell stacks. *International Journal of Hydrogen Energy* 2008;33:4655–64.
- [7] Kurz T, Keller J. Heat management in a portable high temperature PEM fuel cell module with open cathode. *Fuel Cells* 2011;11:518–25.
- [8] Zhang Jianlu, Xie Zhong, Zhang JiuJun, Tang Yanghua, Song Chaojie, Navessin Titichai, et al. High temperature PEM fuel cells. *Journal of Power Sources* 2006;160:872–91.
- [9] Li Qingfeng, Jensen Jens Oluf, Savinell Robert F, Bjerrum Niels J. High temperature proton exchange membranes based on polybenzimidazoles for fuel cells. *Progress in Polymer Science* 2009;34:449–77.

- [10] Andreasen Søren Juhl, Kær Søren Knudsen. Dynamic model of the high temperature PEM fuel cell stack temperature. *ASME Journal of Fuel Cell Science and Technology* 2009; 6(041006):1–8.
- [11] Andreasen Søren Juhl, Kær Søren Knudsen. 400 W high temperature PEM fuel cell stack test. *Electrochemical Society Transactions* 2007;5:197–207.
- [12] Andreasen Søren Juhl, Vang Jakob Rabjerg, Kær Søren Knudsen. High temperature PEM fuel cell performance characterisation with CO and CO₂ using electrochemical impedance spectroscopy. *International Journal of Hydrogen Energy* 2011;36:9815–30.
- [13] Pan Chao, He Ronghuan, Li Qingfeng, Jensen Jens O, Bjerrum Niels J, Hjulmand Henrik A, et al. Integration of high temperature PEM fuel cells with a methanol reformer. *Journal of Power Sources* 2005;145:392–8.
- [14] We Wei, Pai Che-Chuan. Control of a heat-integrated proton exchange membrane fuel cell system with methanol reforming. *Journal of Power Sources* 2009;194: 920–30.
- [15] Horng Rong-Fang. Transient behaviour of a small methanol reformer for fuel cell during hydrogen production after cold start. *Energy Conversion and Management* 2005;46: 1193–207.
- [16] Jörissen L, Scholta J, Messerschmidt M, Hartnig Ch. Externally cooled high temperature polymer electrolyte membrane fuel cell stack. *Journal of Power Sources* 2009;190: 83–5.