



Aalborg Universitet

AALBORG UNIVERSITY  
DENMARK

## Distributed Interference Cancellation for Cognitive Radios Using Periodic Signals of the Primary System

Nishimori, Kentaro; Yomo, Hiroyuki; Popovski, Petar

*Published in:*  
I E E Transactions on Wireless Communications

*DOI (link to publication from Publisher):*  
[10.1109/TWC.2011.062911.101524](https://doi.org/10.1109/TWC.2011.062911.101524)

*Publication date:*  
2011

*Document Version*  
Early version, also known as pre-print

[Link to publication from Aalborg University](#)

*Citation for published version (APA):*  
Nishimori, K., Yomo, H., & Popovski, P. (2011). Distributed Interference Cancellation for Cognitive Radios Using Periodic Signals of the Primary System. *I E E Transactions on Wireless Communications*, 10(09), 2971 – 2981. <https://doi.org/10.1109/TWC.2011.062911.101524>

### General rights

Copyright and moral rights for the publications made accessible in the public portal are retained by the authors and/or other copyright owners and it is a condition of accessing publications that users recognise and abide by the legal requirements associated with these rights.

- ? Users may download and print one copy of any publication from the public portal for the purpose of private study or research.
- ? You may not further distribute the material or use it for any profit-making activity or commercial gain
- ? You may freely distribute the URL identifying the publication in the public portal ?

### Take down policy

If you believe that this document breaches copyright please contact us at [vbn@aub.aau.dk](mailto:vbn@aub.aau.dk) providing details, and we will remove access to the work immediately and investigate your claim.

# Distributed Interference Cancellation for Cognitive Radios Using Periodic Signals of the Primary System

Kentaro Nishimori, *Member, IEEE*, Hiroyuki Yomo, *Member, IEEE* and Petar Popovski, *Member, IEEE*

**Abstract**—This paper considers secondary usage of spectrum resources that are allocated to frequency division duplexing (FDD)-based cellular systems. We propose an interference cancellation technique using the concept of distributed antenna array. We show that the interference from the primary cellular system can be cancelled at a secondary node equipped with single antenna by introducing a *helper* that decodes the interference and transfers it to the secondary node. Interference is forwarded during the time periods in which training signals are transmitted within the primary cellular system. Since the duration of those intervals is short relative to periods for data transmission in the primary system, we introduce a scheme by which the helper compresses the interference before forwarding it. The performance advantage of our scheme is verified by computer simulation, where both analytical and measured channel models are used. The measurement data used in evaluations have been obtained through outdoor experiments while assuming a short-range secondary system. The results indicate that the proposed method for distributed interference cancellation leads to performance benefit, in particular under heterogeneous path loss conditions between the *helper* and the primary/secondary nodes.

**Index Terms**—secondary spectrum usage, periodic training signal, FDD systems, distributed array, interference information transfer

## I. INTRODUCTION

**D**ue to the immense popularity of mobile phones and wireless LAN systems, increasing the data rate within a limited spectrum is one of the most important goals for wireless system design. The spectrum utilization can be dramatically improved if we allow a system to utilize dynamically not only a dedicated frequency band, but also frequencies that are allocated to other systems. This concept is referred to as *dynamic spectrum access (DSA)* [1][2]. According to this principle, a frequency band allocated to a certain primary user can be opportunistically used by another system, called *secondary system* or *cognitive radio*, provided that there are

schemes to avoid/mitigate interference between the primary and the secondary system.

As a target scenario of DSA, we focus on the co-existence between a legacy primary system and a secondary system that is subsequently deployed. In particular, we consider a cellular primary system with frequency division duplexing (FDD) and time division multiple access (TDMA). We consider the *commons model* [3], in which secondary nodes attempt to transmit even if there are ongoing transmissions by primary nodes which can be interfered. In order to realize such a *dense co-existence*, the interference caused by secondary nodes toward primary receivers is a critical issue, which is in general the main focus of research community of cognitive radio. However, considering that the secondary system is a *new* system deployed within a service area of the *legacy* cellular system, it is reasonable to assume that a secondary node has the capability to decode the signals exchanged in the primary system. This enables the secondary node to easily identify time slots to transmit without causing harmful interference toward primary receivers. At first, the secondary nodes observe signals transmitted by primary terminals and estimate relative distance to each of them. With this information, each secondary node knows to which of the primary terminals it can cause harmful interference. Second, by decoding the control frame of the primary system, each secondary node can obtain scheduling information about the primary system. This allows each secondary node to identify time slots allocated to primary nodes that are too far to cause harmful interference. However, even if the interference toward the primary receivers is avoided, the secondary nodes are always exposed to the signals transmitted by primary transmitters. This paper investigates techniques for managing this second type of interference, i. e., interference caused by primary transmitters toward the secondary receivers.

In this paper, we consider a secondary system consisting of access point (AP) and terminal stations (TSs) and we propose an interference cancellation technique [4] based on the concept of *distributed array* (also called as virtual array) [5]–[8]. While the AP can have array antenna to cancel the interference from primary transmitters, each TS is likely to have *a few* antennas due to its size limitation. This motivates us to introduce distributed array for each TS to decode signals transmitted from AP under the interference caused by primary transmitters. Although the proposed method can be applicable for secondary uplink (TS to AP), the merit in the secondary uplink is smaller than that in secondary downlink, because

Manuscript received August 26, 2010; revised February 2, 2011; accepted May 26, 2011. The associate editor coordinating the review of this paper and approving it for publication was Dr. S. Sfar.

Kentaro Nishimori is with the Faculty of Engineering, Niigata University, Ikarashi 8050 Nishi-ku, Niigata 950-2102, 239-0847 Japan (e-mail: nishimori@m.ieice.org).

H. Yomo and P. Popovski are with the Department of Electronic Systems, Aalborg University, Niels Jernes Vej 12, DK-9220 Aalborg, Denmark. H. Yomo is also with the Faculty of Engineering Science, Kansai University, 3-3-35 Yamate-cho, Suita, Osaka, 564-8680 Japan (e-mail: yomo@kansai-u.ac.jp, petarp@es.aau.dk).

Digital Object Identifier 10.1109/TWC.2011.101524.

the AP might have sufficient number of antennas not only for MIMO transmission but also interference cancellation unlike TS.

In the recent years, distributed array has been primarily used to improve the overall system capacity or to obtain a diversity gain. On the other hand, the *relay stations* or *helpers* that constitute the distributed array can also be utilized for interference cancellation [9][10]. The helper (relay) forwards information about the interference which is used by a secondary receiver to decode the desired signal. The ideas of forwarding interference have been considered in [9][10]: when a destination node receives its desired signal and weak interference, instead of forwarding the desired signal, the relay forwards information about the interference. The objective is to make the interfering signal stronger at the destination such that it can be decoded and removed. While the treatment in [9][10] is information-theoretic, in this work, we focus on a more practical setting with concrete system/modulation parameters, as well as a complete procedure for channel estimation, which is a prerequisite for realizing the distributed interference cancellation.

Note that our target is to enable secondary transmissions even under continuous interference from the primary transmitters. This makes the design of the distributed interference cancellation more challenging: the helper needs to forward information about interference in the past to the secondary receiver while it receives new interference generated by a primary transmitter. We address this problem by exploiting periodic intervals in the primary system in which training signals are transmitted to facilitate synchronization and channel estimation of primary nodes. The secondary nodes take advantage of the known timing and content of training signals. However, in the cellular systems the length of the data period is much longer than that of the training period. For example, the data length is approximately 5 times longer than the training length in GSM [11]. Therefore, we also introduce *interference compression* where the interference is transferred by re-mapping of the original constellation used in the primary systems into a constellation of a higher order.

A related work has been presented by the authors in [4] and this manuscript brings significantly broadened treatment of the proposed approach. In particular:

- In this paper, multiple antennas are considered not only for the AP but also for the TS because multiple input multiple output (MIMO) systems have been practically developed in systems such as IEEE802.11n and LTE.
- In the previous study ideal knowledge of the channel state information (CSI) was assumed. In this study, we propose CSI estimation method based on Least Square (LS) method.
- The period in which the helper transmits interference information to the TS acts as an overhead for the method proposed in [4]. Therefore we propose another scheme, in which the interference information can be extracted without overhead by utilizing the SNR difference between the relay or helper/TS and AP/TS.
- In a practical setting, antenna heights for primary and secondary nodes can be different. Therefore, we introduce a practical path loss model which takes the antenna

height into account, leading to heterogeneous path loss conditions for links that have different antenna heights.

- We investigate the performance of the proposed scheme with propagation parameters that are obtained through outdoor measurements assuming a cellular-based primary system and a short-range secondary system.

The rest of the paper is organized as follows. Section II describes our target scenario and problem definition. Section III presents the proposed technique for distributed interference cancellation. Section IV provides quantitative performance analysis of the proposed scheme with theoretical propagation models while evaluation results are also presented with propagation measurements. The last section concludes the paper.

## II. TARGET SCENARIO AND PROBLEM DEFINITION

### A. Target scenario

Fig. 1 shows an example of our target scenario. The characteristics of systems covering large areas are significantly different from those covering small areas. Our strategy utilizes the features of both systems in order to reach an efficient state of coexistence [3][12]. We assume a typical cellular system with TDMA-FDD as shown in the figure. It is reasonable to assume FDD in the long-range system [13]. One base station (BS) communicates with several subscriber stations (SSs) over a frequency channel. Different time slots are allocated to SSs over a frequency channel as shown in Fig. 1. The frequencies  $f_1(j)$  and  $f_2(j)$  represent frequency channel for downlink and for uplink, respectively, while  $j$  ( $j = 1, \dots, L$ ) denotes the channel number and  $L$  is the total number of frequency channels. In Fig. 1, three SSs (SS1, SS2 and SS3) communicate with a BS over a frequency channel using the time slots  $t_{1D}$  ( $t_{1U}$ ),  $t_{2D}$  ( $t_{2U}$ ), and  $t_{3D}$  ( $t_{3U}$ ) in downlink (uplink) channel.

We consider a secondary system with shorter communication range than the primary system which attempts to reuse the frequency band given to the primary system. Since the communication is locally restricted, such a secondary system has high potential to flexibly find available space within the primary service area.

In this paper, the downlink bands ( $f_1(\cdot)$ ) assigned to the corresponding cell (i. e., the cell within which the secondary system is located) according to the frequency planning of the primary system are reused by secondary transmissions. We do not allow the secondary system to reuse the frequency bands assigned to the other cells since it can violate frequency planning of the cellular system. The ad-hoc use of preplanned frequencies requires careful considerations on resource management to prevent the increase of inter-cell interference, which is outside the scope of this paper. Here, we investigate an efficient way to reuse the frequency bands under interference from the primary system, which can be used as a building block to propose a resource allocation algorithm that attempts to reuse all the bands in the cellular system considering frequency reuse patterns.

As shown in Fig. 1, it is assumed that the BS always sends in the downlink, while the SSs need to receive their desired signals only in scheduled time slots. The secondary nodes can make transmissions as long as they do not cause interference

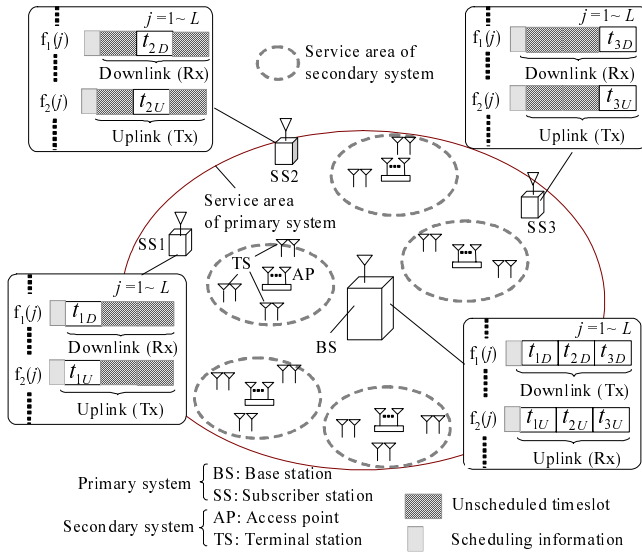

Fig. 1. Target scenario.

toward the scheduled primary SSs. The secondary nodes measure the power level of the signals received from each SS over an uplink band. When the interference power from a certain SS is negligible at a secondary node, we assume that the corresponding secondary transmission creates negligible interference toward that SS. Furthermore, we assume that secondary nodes are able to decode the primary signals and to obtain scheduling information which is sent as control information at the beginning of the transmission frame in the primary system. Considering the recent developments of software defined radio (SDR) technologies [14], it is reasonable to assume that the secondary nodes have a sufficient reconfigurability to receive signals from multiple systems [15]. Thus, each secondary node can identify the time slots in which it can transmit without causing harmful interference toward scheduled SSs.

The secondary system should consider broadband transmission. Hence, OFDM or single carrier frequency domain equalizer at receiver site should be assumed [16][17], considering the recent trends in wireless communications. In the evaluation of Section IV, we consider OFDM transmission for the secondary system, and the results for one subcarrier in OFDM transmission are given in Section IV.B. Moreover, if the frequency domain signal processing at the secondary receiver is assumed for the primary signals, then the primary signals can be regarded as flat faded at each sub-carrier, which is a reasonable assumption. The actual OFDM signals are transmitted in Section IV.C by using measured data.

### B. Problems for the conventional adaptive arrays in the presence of continuous interference

Even if the secondary nodes avoid the interference toward the primary SSs, the AP and the TS in the secondary system are interfered by the primary BS. Hence, the secondary nodes need to cancel the interference from the primary BS. Interference cancellation using an array antenna is known as one of the techniques for reducing the co-channel interference [18]. Moreover, since MIMO systems have been developed in

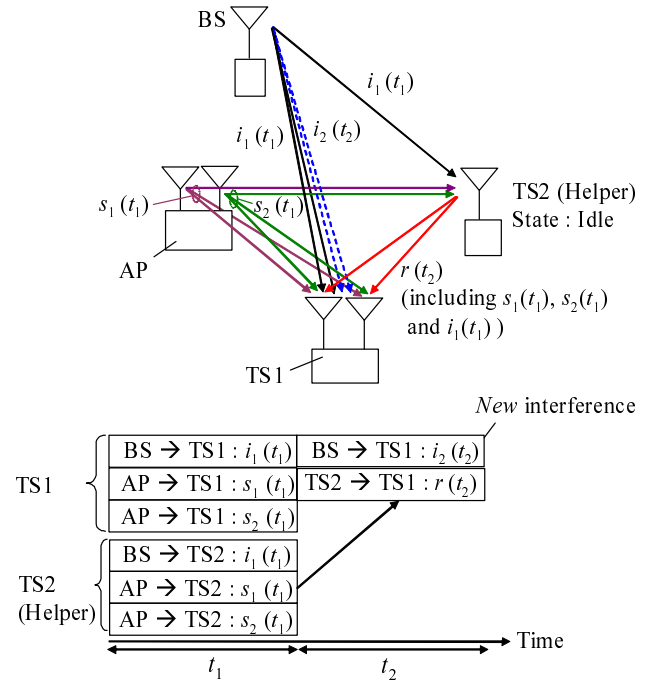

Fig. 2. Concept of distributed array and a problem of continuous interference.

Wireless LAN and LTE systems, it is reasonable to assume that multiple antennas and transceivers are implemented at both AP and TS. Fig. 2 shows a system model where a MIMO transmission is employed between the AP and TS while the interference arrives at TS from the primary transmitter. As it can be seen in Fig. 2, the TS cannot decode the desired signals ( $s_1(t_1)$ ,  $s_2(t_1)$ ) when the total number of signals exceeds the number of antennas at TS. On the other hand, a few antennas at the mobile TSs are desirable due to their size limitations and power consumption.

Therefore, we apply interference cancellation by using the concept of *distributed array* [5]–[8]. Moreover, several types of cooperative transmission are proposed [19]–[21]. In such cooperative transmission schemes, it is assumed that the relay station itself can decode and de-modulate signals. Such a cooperative scheme is called virtual MIMO or distributed array [19]. A scenario where the distributed array is applied is also shown in Fig. 2: TS2 is idle (does not have communication traffic) and is used as one side of the distributed array. If TS2 receives the desired and interference signals, and these signals are transferred to TS1 which communicates with the AP, the distributed array can function as a virtual array at TS1. Well-known interference cancellation algorithms such as zero forcing (ZF), MMSE, V-BLAST and maximum likelihood detection (MLD) schemes can be applied [16][22].

However, there is a problem on realizing distributed array under continuous primary interference in the FDD downlink. TS1 and TS2 receive interference  $i_1(t_1)$  at  $t_1$ , and this interference signal should be transferred from TS2 to TS1, e. g., at  $t_2$  as shown in Fig. 2. However, new interference  $i_2(t_2)$  is simultaneously received at TS1 while TS2 transmits  $i_1(t_1)$  to TS1. Hence, when we consider the continuous interference from the primary BS, TS1 cannot eliminate the new interference  $i_2(t_2)$  which is generated while  $r(t_2)$  (including

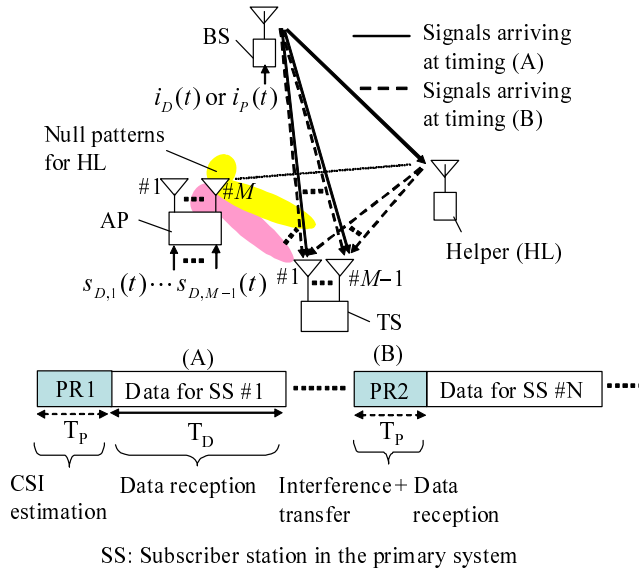

Fig. 3. Concept of the proposed distributed interference cancellation.

$s_1(t_1)$ ,  $s_2(t_1)$  and  $i_1(t_1)$ ) is sent from TS2 to TS1.

### III. DISTRIBUTED INTERFERENCE CANCELLATION BY USING THE PERIODIC TRAINING SIGNALS OF THE PRIMARY SYSTEM

#### A. The basic principle

In this section, we propose a distributed array which can cancel a continuous interference from the primary BS. Fig. 3 shows the concept. As in a conventional distributed array, the proposed scheme also utilizes helpers or relays. However, by exploiting periodic training sequences in the primary system, the proposed scheme enables secondary transmissions even in presence of continuous interference from the primary system.

We show a signal format of the primary system, which is typically used in TDMA in Fig. 3. As shown in this figure, the time periods to transmit training signal ( $T_P$ ) and data signal ( $T_D$ ) are repeated for each SS. The training signal is transmitted for BS and SSS in the primary system to acquire the initial timing of communication and carrier synchronization. This is usually called preamble signal and is the same for all SSS. The signal format of the preamble employed in the legacy primary system is assumed to be known by the secondary system. As shown in Fig. 3, the secondary system employs MIMO transmission. The numbers of antennas at AP, TS, and HL are set to be  $M$ ,  $M-1$  and 1, respectively. In other words, *virtual*  $M \times M$  MIMO channel is created among AP, TS, and HL.

We exploit the periodic intervals used for training sequences in order to cancel interference with the distributed array. The proposed scheme consists of the following three stages. First, the CSI of the secondary links as well as the CSI from the BS to secondary receivers is obtained during the Preamble 1 (PR1) in Fig. 3. Second, AP transmits  $M-1$  data streams,  $s_{D,i}(t)$  ( $i = 1 \sim M-1$ ) to TS during the data period for SS 1 in the primary system by using Eigenmode transmission [23]. Here, AP creates nulls in their antenna patterns toward HL by using the CSI between AP and HL. Hence, HL receives

only interference from BS. On the other hand, TS receives the desired signals from AP,  $s_{D,i}(t)$  ( $i = 1 \sim M-1$ ) and interference from BS,  $i_D(t)$  during this period. Third, the interference received from BS during the data period for SS 1 is transferred from HL to TS during the period of Preamble 2 (PR2) in Fig. 3. Although new interference from PT,  $i_P(t)$  is received at TS during this period, this preamble signal,  $i_P(t)$  can be cancelled by TS as the secondary system knows the preamble sequence *a priori*. Thus, TS can decode and cancel the primary interference by using the information about the interfering signal transferred from HL and the known preamble signal. Moreover, it is reasonable to assume that the SNR between HL and TS is much larger than that between AP and TS, because the helper (relay) should be located near TS. When considering the above assumption, the information for the interference transfer from HL to TS can be decoded even if the desired signal from AP to TS is transmitted at this period.

#### B. Details of the proposed scheme

The above three stages of the proposed scheme can be further detailed into the following six steps:

- 1) All CSI (AP/TS, AP/HL, BS/TS, BS/HL, HL/TS) estimations are carried out using the training period (PR1 in Fig. 3).
- 2) AP transmits signals to TS by creating a null toward HL during the data period of SS 1.
- 3) The interference incurred during the data period of SS 1 is decoded by using the received signal at HL and the CSI from Step 1.
- 4) HL transmits the interference obtained in Step 3 to TS during the next training period (PR2 in Fig. 3).
- 5) The interference incurred during the data period for SS 1 is estimated from the received signal at TS and the CSI from Step 1.
- 6) The desired signal for TS is estimated using the interference decoded in Step 5, the received signal in Step 2, and the CSI from Step 1.

The details of each step are given in the sequel. Although we treat only one TS, the proposed scheme can be straightforwardly applied to multiple TSs. We assume that HL associated with a secondary node has been already determined.

In Step 1, we divide the period PR1 into three parts as shown in Fig. 4 in order to estimate all the required CSIs. During the Period 1, AP stops its transmission toward the TS and HL such that only the CSI of the interference from BS to HL and TS is acquired. The received signals  $x_{P1}(t) \in \mathbb{C}^{(M-1) \times 1}$  and  $x_{P1,M}(t)$  at TS and HL for Period 1 ( $1 \leq t \leq T_{P1}$ ,  $t$  is the symbol number) are given as follows:

$$x_{P1}(t) = \mathbf{h}_I i_P(t) + \mathbf{n}_P(t) \quad (1)$$

$$x_{P1}(t) = [x_{P1,1}(t), \dots, x_{P1,M-1}(t)]^T \quad (2)$$

$$\mathbf{n}_P(t) = [n_{P1,1}(t), \dots, n_{P1,M-1}(t)]^T \quad (3)$$

$$\mathbf{h}_I(t) = [h_{I,1}, \dots, h_{I,M-1}]^T \quad (4)$$

$$x_{P1,M}(t) = h_{I,M} i_P(t) + n_{P,M}(t) \quad (5)$$

where  $\mathbf{h}_I \in \mathbb{C}^{(M-1) \times 1}$  and  $h_{I,M}$  denote the channel responses of the interfering signals for TS and HL, respectively.  $i_P(t)$  represents the *known* preamble signals from the primary

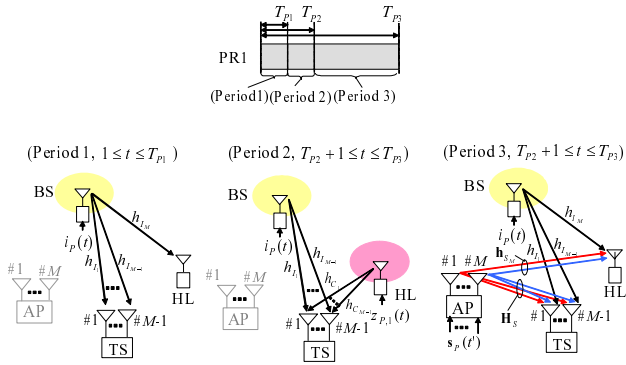

Fig. 4. CSI estimation in proposed method.

transmitter.  $\mathbf{n}_P(t) \in \mathbb{C}^{(M-1) \times 1}$  and  $n_{P,M}(t)$  represent the thermal noise for TS and HL, respectively.

During the Period 2, a signal is transmitted by HL so that  $\mathbf{h}_C \in \mathbb{C}^{(M-1) \times 1}$  (between TS and HL) is obtained. During this period, AP stops its transmission in order not to cause any interference to TS. The received signals  $\mathbf{x}_{P2}(t) \in \mathbb{C}^{(M-1) \times 1}$  in Period 2 ( $T_{P1} + 1 \leq t \leq T_{P2}$ ,  $T_{P2} = 2T_{P1}$ ) are

$$\mathbf{x}_{P2}(t) = \mathbf{h}_I i_P(t) + \mathbf{h}_C z_{P,1}(t) + \mathbf{n}_P(t), \quad (6)$$

$$\mathbf{x}_{P2}(t) = [x_{P2,1}(t), \dots, x_{P2,M-1}(t)]^T, \quad (7)$$

$$\mathbf{h}_C(t) = [h_{C1}, \dots, h_{C_{M-1}}]^T, \quad (8)$$

where  $z_{P,1}(t)$  represents the *known* preamble signals from HL to TS.

Finally, in order to estimate CSIs between AP/TS and AP/HS, AP transmits preamble signals,  $\mathbf{s}_P(t') = [s_{P,1}(1), \dots, s_{P,M}(M)]^T$  to TS and HL during Period 3.  $\mathbf{s}_P(t')$  can be transmitted by using at least  $M$  symbols. Hence  $T_{P3}$  equals to  $T_{P1} \cdot (M + 1)$ . The received signals  $\mathbf{x}_{P3}(t) \in \mathbb{C}^{(M-1) \times 1}$  and  $x_{P3,M}(t)$  at TS and HL for Period 3 ( $T_{P2} + 1 \leq t \leq T_{P3}$ ) are given as

$$\mathbf{x}_{P3}(t) = \mathbf{H}_S \mathbf{s}_P(t) + \mathbf{h}_I i_P(t) + \mathbf{n}_P(t), \quad (9)$$

$$\mathbf{x}_{P3}(t) = [x_{P3,1}(t), \dots, x_{P3,M-1}(t)]^T, \quad (10)$$

$$x_{P3,M}(t) = \mathbf{h}_{S_M} \mathbf{s}_P(t) + h_{I_M} i_P(t) + n_{P,M}(t), \quad (11)$$

where  $\mathbf{H}_S \in \mathbb{C}^{(M-1) \times M}$  and  $\mathbf{h}_{S_M} \in \mathbb{C}^{1 \times M}$  denote the channel responses from AP to TS and HL, respectively, and are represented as follows:

$$\mathbf{H}_S = \begin{pmatrix} h_{S_{1,1}} & \dots & h_{S_{1,M}} \\ \vdots & \ddots & \vdots \\ h_{S_{M-1,1}} & \dots & h_{S_{M-1,M}} \end{pmatrix}, \quad (12)$$

$$\mathbf{h}_{S_M} = [h_{S_{1,M}}, \dots, h_{S_{M,M}}]. \quad (13)$$

All CSIs are obtained by using Eqs. (1) to (11). The least square (LS) criteria is adopted for CSI estimation. The estimated CSIs of BS/HL and BS/TS,  $\tilde{\mathbf{h}}_I = [\tilde{h}_{I1}, \dots, \tilde{h}_{I_{M-1}}]$  and  $\tilde{h}_{I_M}$ , are obtained by using Eqs. (1) and (5), respectively,

as follows:

$$\tilde{\mathbf{h}}_I = \frac{1}{T_{P1}} \sum_{t=1}^{T_{P1}} \left( \frac{\mathbf{x}_{P1}(t)}{i_P(t)} \right), \quad (14)$$

$$\tilde{h}_{I_M} = \frac{1}{T_{P1}} \sum_{t=1}^{T_{P1}} \left( \frac{x_{P1,M}(t)}{i_P(t)} \right). \quad (15)$$

The CSI between HL and TS,  $\tilde{\mathbf{h}}_C = [\tilde{h}_{C1}, \dots, \tilde{h}_{C_{M-1}}]$  is estimated using Eqs. (9) and (14), as

$$\tilde{\mathbf{h}}_C = \frac{1}{T_{P2}} \sum_{t=T_{P1}+1}^{T_{P2}} \left( \frac{x_{P2}(t) - \tilde{\mathbf{h}}_I i_P(t)}{z_{P,1}(t)} \right). \quad (16)$$

The estimated CSIs of AP/TS and AP/HL,  $\tilde{\mathbf{H}}_S$  and  $\tilde{h}_{S_M}$  are obtained by using Eqs.(1), (5), (9), (11), (14) and (15), respectively, as follows:

$$\tilde{\mathbf{H}}_S = \frac{1}{T_{P3}} \left[ \sum_{t=T_{P2}+1}^{T_{P3}} \left( \mathbf{x}_{P3}(t) - \tilde{\mathbf{h}}_I i_P(t) \right) \right] \mathbf{q}, \quad (17)$$

$$\tilde{h}_{S_M} = \frac{1}{T_{P3}} \left[ \sum_{t=T_{P2}+1}^{T_{P3}} \left( x_{P3,M}(t) - \tilde{h}_{I_M} i_P(t) \right) \right] \mathbf{q} \quad (18)$$

$$\mathbf{q} = \frac{1}{T_{P1}} \sum_{t'=1}^{T_{P1}} \left( \mathbf{s}_P(t')^H \mathbf{s}_P(t') \right)^{-1} \mathbf{s}_P(t')^H. \quad (19)$$

In the second step (Step 2), AP transmits signals using Eigenmode transmission scheme [23] to TS with the antenna pattern that creates a null toward the helper during the data period for SS 1 in Fig. 3. The channel matrix between AP and TS,  $\mathbf{H}'_S$  to obtain the above transmission is shown as follows:

$$\mathbf{H}'_S = \mathbf{H}_S \mathbf{U} \mathbf{W} \quad (20)$$

where  $\mathbf{U}$  is eigenvector by the calculation of  $\tilde{\mathbf{H}}_S^H \tilde{\mathbf{H}}_S$ .  $\mathbf{W}$  is the weights for nullifying toward the HL. In this step, TS receives the desired signal plus interference from the primary system. The HL receives only interference from the primary system. The received signals  $\mathbf{x}_D = [x_{D,1}(t), \dots, x_{D,M-1}(t)]^T$  and  $x_{D,M}$  during the data period ( $1 \leq t \leq T_D$ ) at the TS and HL are respectively represented as

$$\mathbf{x}_D(t) = \mathbf{H}'_S \mathbf{s}_D(t) + \mathbf{h}_I i_D(t) + \mathbf{n}_D(t), \quad (21)$$

$$x_{D,M}(t) = h_{I_M} i_D(t) + n_{D,M}(t), \quad (22)$$

where  $\mathbf{s}_D(t) = [s_{D,1}(t), \dots, s_{D,M-1}(t)]$  and  $i_D(t)$  represent *unknown* data signals for TS from AP and PT, respectively. Thus, TS must decode and cancel interference  $i_D(t)$  without any information pertaining to the interference.

$\mathbf{s}_D(t)$  cannot be decoded by using the procedure in Steps 1 and 2. On the other hand, interference  $i_D(t)$  can be estimated at HL using Eq. (22) and  $\tilde{h}_{I_M}$  obtained in Step 1. In Step 3, HL uses LS method to decode the interference that occurs during the data period of SS 1. The decoded interference  $\tilde{i}_D$  is obtained using Eqs. (15) and (22) as

$$\tilde{i}_D(t) = \frac{1}{T_D} \sum_{t=1}^{T_D} \left( \frac{x_{D,M}(t)}{\tilde{h}_{I_M}} \right), \quad (23)$$

where  $T_D$  denotes the length of symbols for data period.

In Step 4 HL transmits the interference  $\tilde{i}_D(t)$  estimated in Step 3 to TS by using the next training period (PR2 in Fig. 3). However, as it can be seen in Fig. 3, the length of the data sequence is usually much longer than that of the preamble. Hence, a key issue is how to compress the interference in order to fit in the short preamble period. To this end, we propose a *re-mapping* technique for the modulated signal. We can assume that binary phase shift keying (BPSK) or Gaussian filtered Minimum Shift Keying (GMSK) [25] modulation is used in the primary system as it is viable to assume that the legacy system is narrowband. As an example, BPSK is assumed to be used in the primary system. On the other hand, secondary system is assumed to use higher constellations, such as 64QAM. For instance, IEEE802.11a/g WLAN standard can use up to 64QAM modulation [24]. The constellation size may grow for the future high-speed cognitive systems. This fact means that the interference from BS can be *compressed* at HL, such that the transmission of interference can take less time compared to the transmission in the primary system. For example, if we employ 16QAM modulation for the transmission from HL to TS, interference transmission from HL to TS is completed with 1/4 of the time compared to the transmission of the primary system. The received signal at TS during PR2,  $\mathbf{x}'_P(t)$  is shown as follows:

$$\mathbf{x}'_P(t) = \mathbf{H}'_S \mathbf{s}_D(t) + \mathbf{h}_C i_{D, \text{Re-map}}(t) + \mathbf{h}_I i_P(t) + \mathbf{n}_P(t), \quad (24)$$

where  $i_{D, \text{Re-map}}(t)$  is the interference which is compressed by HL.

In Step 5, after the transmission of the interference using the re-mapping, the interference from BS during the period of data for SS 1,  $\tilde{i}_D$ , is estimated by using the received signal in Eq. (24). It is reasonable to assume that  $E[|\mathbf{h}_C|]$  is much larger than  $E[|\mathbf{H}_S|]$ , because the helpers or relay should be located near TS. Moreover,  $\tilde{\mathbf{h}}_I i_P(t)$  is estimated by Step 1. Hence, we prepare  $\mathbf{x}''_P(t) = \mathbf{x}'_P(t) - \tilde{\mathbf{h}}_I i_P(t)$ . Then, the interference is estimated using  $\mathbf{x}''_P(t)$  and  $\tilde{\mathbf{h}}_C$  as,

$$\tilde{i}_{D, \text{Re-map}}(t) = \frac{1}{T_P \cdot (M-1)} \sum_{t=1}^{T_D} \sum_{i=1}^{M-1} \left( \frac{\mathbf{x}''_{P,i}(t)}{\tilde{\mathbf{h}}_{C_i}} \right) \quad (25)$$

After Step 5, de-remapping is carried out in order to recover the original interfering signal. In the above example, 16QAM is mapped to an (estimated) BPSK interference,  $\tilde{i}'_D(t)$ .

In Step 6, the desired signal  $\mathbf{s}_D(t)$  can be estimated by using the interference  $\tilde{i}'_D(t)$  estimated in Step 5, the received signal  $\mathbf{x}_D(t)$  in Step 2, and CSIs  $\tilde{\mathbf{H}}_S$ ,  $\tilde{\mathbf{h}}_I$  obtained in Step 1. The estimated desired signal  $\tilde{\mathbf{s}}_D(t)$  can be denoted as follows:

$$\tilde{\mathbf{s}}_D(t) = \mathbf{V}^H \mathbf{x}'_D(t), \quad (26)$$

where  $\mathbf{V}$  is eigenvector by the calculation of  $\tilde{\mathbf{H}}_S \tilde{\mathbf{H}}_S^H$ . Here,  $\mathbf{x}'_D(t)$  is denoted as,

$$\mathbf{x}'_D(t) = \mathbf{x}_D(t) - \tilde{\mathbf{h}}_I \tilde{i}'_D(t). \quad (27)$$

#### IV. PERFORMANCE EVALUATION

##### A. Simulation conditions and reference schemes

In this section, we evaluate the performance of the proposed method by computer simulation. Fig. 5 represents the configurations of the proposed and reference schemes. We compare

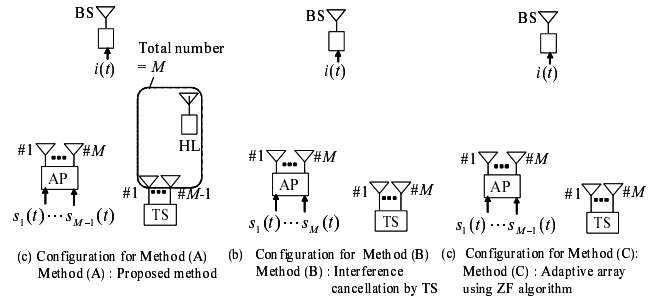

Fig. 5. Configurations of the proposed and reference schemes.

the proposed interference cancellation (Fig. 5 (a), Method (A)) with the following reference schemes (Fig. 5 (b) and (c)):

Method (B) : Interference cancellation by TS

Method (C) : Adaptive array using ZF algorithm

For a fair comparison, the total number of antennas at the transmitter and receiver sites are identical among Method (A) to (C). The numbers of antennas at AP and TS are  $M$ , respectively, in Method (B) and (C). The number of antennas at AP is  $M$  and the number of antennas at HL plus TS is also  $M$  in Method (A). The number of data streams is set to be  $M-1$  for Method (A) and (C) while the number of data streams is set to be  $M$  for Method (B) because the Method (A) needs to create a null toward the HL from the AP and Method (C) needs to cancel the interference using the freedom of the array. Eigenmode transmission is adopted as a MIMO transmission by using scheme for Method (A) to (C).

As shown in Fig. 5, the interference in method (B) is mitigated only by using the antennas at the TS while there is an aid from HL in the proposed method. The principle of Method (B) is the same as the proposed method except for the usage of HL. First, the decoded interference in Method (B) is denoted as

$$\tilde{i}''_D(t) = \frac{1}{T_D \cdot M} \sum_{t=1}^{T_D} \sum_{i=1}^M \left( \frac{x_{D,i}(t)}{\tilde{\mathbf{h}}_{I_i}} \right). \quad (28)$$

Next, the signal,  $x''_{D,i}(t)$  in which the interference is cancelled is

$$x''_{D,i}(t) = x_{D,i}(t) - \tilde{\mathbf{h}}_{I_i} \tilde{i}''_D(t) \quad (i = 1 \sim M). \quad (29)$$

After this processing, MIMO decoding using Eq.(26) is employed.

In method (C), TS uses an adaptive array with Zero-Forcing (ZF), such that the decoded signal is (30) on the next page.

The relationship between the data period and the training period is defined as

$$R_a = \frac{T_D}{T_P} \quad (31)$$

where  $T_D$  and  $T_P$  denote the length of the data period and the preamble in the primary system, respectively.

Secondary transmissions from AP to TS use adaptive modulation. Table I shows the required signal to noise power ratio (SNR) for different modulation levels. The SNR for each modulation scheme in Table I gives bit error rate (BER) of  $5 \times 10^{-3}$  [27]. For all the methods, the modulation level is decided based on the SNR.

$$\begin{pmatrix} \tilde{s}_{D,1} \\ \vdots \\ \tilde{s}_{D,M-1} \\ i_D \end{pmatrix} = \begin{pmatrix} h'_{S_{1,1}} & \cdots & h'_{S_{1,M-1}} & h_{I_1} \\ \vdots & \ddots & \vdots & \vdots \\ h'_{S_{M,1}} & \cdots & h'_{S_{M,M-1}} & h_{I_M} \end{pmatrix}^{-1} \begin{pmatrix} x_{D,1} \\ \vdots \\ x_{D,M} \end{pmatrix} \quad (30)$$

TABLE I  
REQUIRED SNR FOR DIFFERENT MODULATION LEVELS

SNR	Modulation
3.63 dB	BPSK
8.40 dB	QPSK
12.08 dB	8-QAM
15.39 dB	16-QAM
18.55 dB	32-QAM
21.63 dB	64-QAM
24.67 dB	128-QAM
27.70 dB	256-QAM
30.72 dB	512-QAM
33.73 dB	1024-QAM

When the proposed interference cancellation is used, the modulation level employed for interference transfer from HL to TS is also determined from Table I. For simplification,  $R_a$  is set to be integer in this study. For example, let us assume that the modulation employed by BS is BPSK. When  $R_a$  is set to be 4 or 8, the required modulation level is 16QAM or 256QAM, respectively. We assume that the data packet is lost when the modulation level available for transmission from HL to TS is less than the required modulation level which is determined by  $R_a$ .

The total transmission rate,  $R$ , is defined as

$$R = \frac{\sum_{k=1}^{N_F} R(k)}{N_F}, \quad (32)$$

$$R(k) = M_a [1 - BER(k)] \quad (33)$$

where  $N_F$  represents the number of frames.  $M_a$  denotes the number of bits per symbol when applying the adaptive modulation.  $R(k)$  and  $BER(k)$  are the transmission rate and BER for  $k$ -th frame, respectively. For simulation, we set  $T_D = 600$ ,  $T_P = T_D/R_a$ , and  $N_F = 20000$ .

When considering installation of antennas, the antenna height of TS is low ( $< 2$  m) while AP can be deployed in a relatively high position. The relay station is generally located at the top of utility pole or building to obtain a line-of-sight (LoS). BS, in general, is deployed at a much higher place. Hence, we need a model which can take account of heterogeneous path loss conditions, occurring due to different antenna heights. To this end, we employ Ichitsubo's path loss model, in which path loss coefficient is related with the antenna heights for the transmitter and receiver [12][28]. The parameters for this evaluation are shown in Table II.

### B. Comparison of the transmission rates

The intensity of the interference depends on the relative location of the secondary system with respect to the primary

TABLE II  
PARAMETERS FOR HETEROGENEOUS PATHLOSS CONDITIONS

Antenna height, $h_{PT}$	30 m
Antenna height, $h_{AP}$	10 m
Antenna height, $h_{HL}$	10 m
Antenna height, $h_{TS}$	10 m
Distance between AP and TS, $d_1$	100 m
Distance between BS and TS, $d_2$	200~2000 m
Distance between HL and TS, $d_3$	50~90 m

BS and it has a large impact on the secondary transmission. Fig. 6 shows the transmission rate comparison among the three methods in Fig. 5. Fig. 6 (a) shows the transmission rate versus the average signal to interference power ratio (SIR). Fig. 6 (b) depicts the transmission rate comparison versus the total number of antennas at AP and TS (and HL in the proposed method),  $M$ . The average SNR between AP and TS in the secondary system is fixed to be 20dB. We assume that the average SIRs at TS and HL are same and equal to 0 dB. Rayleigh fading for all channel responses is assumed. The modulation scheme employed by BS is BPSK. Hence,  $2^{R_a}$  QAM is required for the transmission from HL to TS for the given  $R_a$ .  $R_a$  is set to 8 in this figure. The total numbers of antennas at AP and TS (and HL in the proposed method),  $M$  are set to be 3 in Fig. 6(a).

When we compare the proposed method and Method (B) in Fig. 6(a), we find that the best method differs depending on the value of SIR. At low SIR ( $< -12$  dB), the Method (B) is effective because the desired signal is negligible and the interference is successfully decoded with high probability. When SIR is higher than -12dB, the proposed method has the better performance. Since the Method (C) can completely cancel the interference regardless of the interference power, it achieves higher transmission rate than Method (B). However, the proposed method obtains a higher transmission rate than Method (B) due to the aid of the HL regardless of smaller number of antennas at TS in the proposed method.

Fig. 6 (b) shows the transmission rate when considering only SIR = 0 dB for the proposed method and Method (C). The transmission rates in these methods do not depend on the SIR. On the other hand, since the transmission rate in Method (B) is greatly affected by the SIR as shown in Fig. 6 (a), the results when SIRs = -15, -10, -5 and 0 dB are plotted in Fig. 6 (b). As shown in Fig. 6 (b), we confirm that the proposed method achieves a higher transmission rate than the Method (C) when the total number of antennas  $M$  is increased. Hence, it is shown that the proposed scheme is effective when considering MIMO transmission in the secondary systems. Moreover, from this figure, we can conclude that the proposed method and Method (B) should be adaptively selected accord-



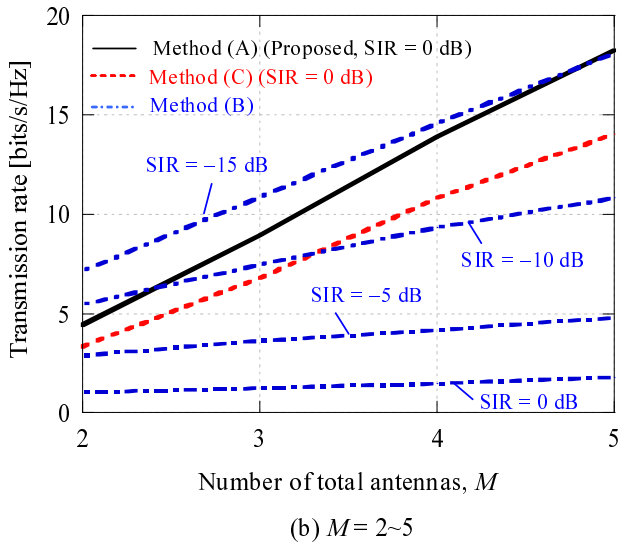
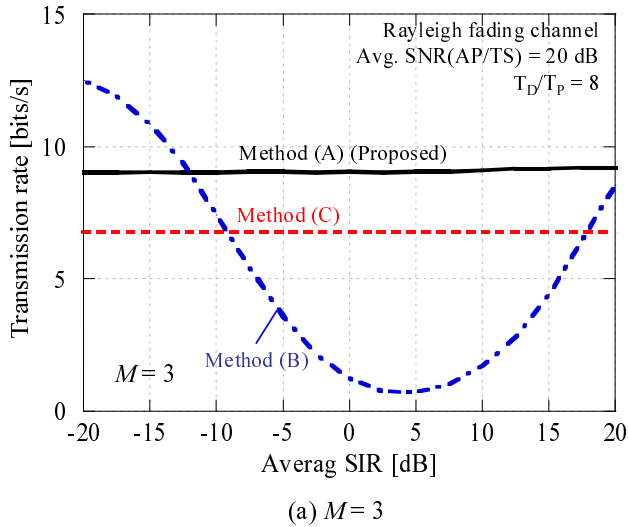

Fig. 6. Transmission rate versus average SIR.

ing to SIR, i. e., the location of the secondary system within communication range of the primary BS.

Fig. 7 shows the transmission rate versus  $R_a$ . As it can be seen in Fig. 7, the proposed method obtains higher transmission rate than Method (B) and (C) regardless of the value of  $R_a$ . Even if  $R_a = 10$ , 1.3 bits/s higher bit rate by the proposed method is obtained than that by Method (C).

The distance between HL and TS is an important parameter in the proposed method, which determines the ability for decoding the interference. The transmission rate of the proposed method versus the distance between HL and TS is plotted in Fig. 8. Here,  $R_a$  is set to 4 and 8, which requires modulation levels of 16QAM and 256QAM, respectively. As Fig. 8 shows, the proposed method obtains higher transmission rate than Method (B) and (C) regardless of the value of  $R_a$  although the transmission rate is gradually decreased as the distance between HL and TS increases in the proposed scheme when  $R_a = 8$ .

Fig. 7. Transmission rate versus  $T_D/T_P$ .

Fig. 8. Transmission rate versus average SNR between HL and TS.

### C. Evaluations using measured channel data in an actual outdoor environment

In order to evaluate the proposed method in a practical setting, we have carried out outdoor measurements to gather propagation data at an urban area in Japan. Fig. 9 shows the measurement environment. The BS antenna of the primary system was placed at the top of a steel tower with a height of 50 m. The AP and HL are located at R1 to R6 in Fig. 9. We assume that AP and HL are positioned as two neighborhood relay stations (e.g., R1 and R3 for AP and HL, respectively). The antenna of TS was mounted on the top of a car with the height of 2.2 m. Table III shows the measurement parameters.

In this measurement, the OFDM signals are transmitted in order to evaluate the performance of the proposed method in broadband transmission. The frequency of 4.8 GHz was used for this measurement. The channel responses between BS/TS, AP/TS, BS/HL, HL/TS are obtained by using OFDM signals with 20MHz bandwidth. The number of antennas at AP, TS and HL can be set to 4, 4 and 1 at maximum, respectively. The achievable bit rate is obtained by averaging the results in

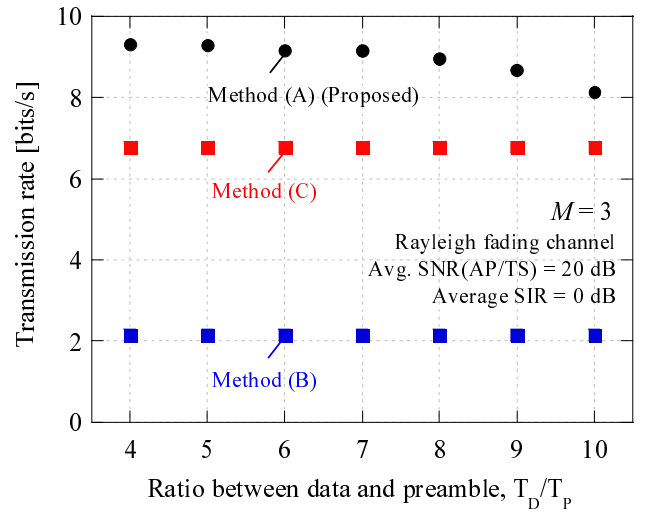
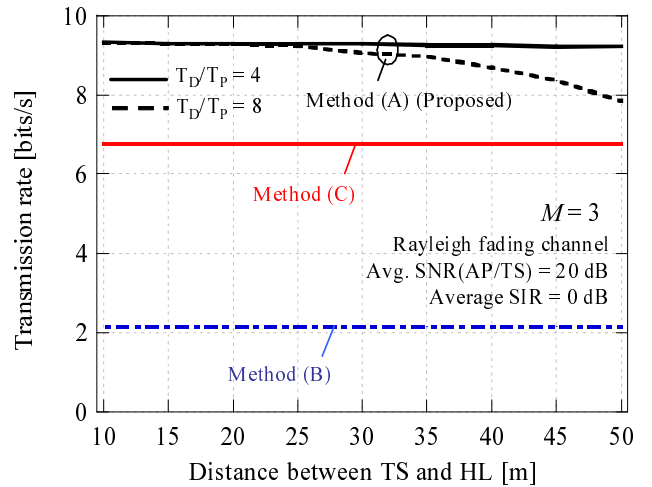
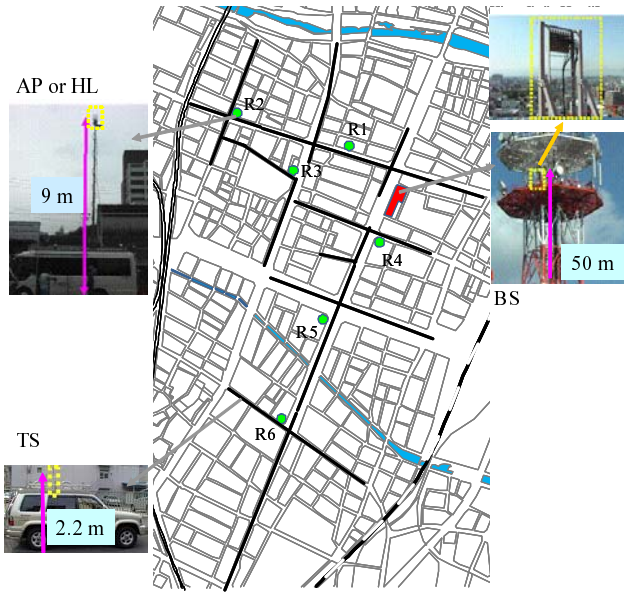

Fig. 9. Measurement environment.

TABLE III  
MEASUREMENT PARAMETERS

Carrier frequency	4.8GHz
Bandwidth	20MHz
Sampling rate (A/D)	40MHz
Sampling rate (D/A)	80MHz
FFT points	128
number of sub-carriers	104
Interval between sub-carriers	157.5KHz

each subcarrier.

Fig. 10 shows the transmission rate versus  $R_a$  when the measured CSI is used. The total numbers of antennas at Tx and Rx are set to be three. The average SNR between AP and TS in the secondary system is normalized so that the average SNR results in 20dB. The average INR between BS and TS is assumed to be the same as the average SNR between AP and TS. From the experimental results we have calculated the following differences.

$$\Delta\gamma_1 = \text{SNR}_{HL-TS} - \text{SNR}_{AP-TS} \text{ [dB]} \quad (34)$$

$$\Delta\gamma_2 = \text{INR}_{BS-HL} - \text{INR}_{BS-TS} \text{ [dB]} \quad (35)$$

where  $\text{SNR}_{AP-TS}$  ( $\text{SNR}_{HL-TS}$ ) is the average received SNR at the link AP-TS (HL-TS).  $\text{INR}_{BS-TS}$  ( $\text{INR}_{BS-HL}$ ) is the average received INR at the link BS-TS (BS-HL). In order to stay consistent with the experiments, if we set the average  $\text{SNR}_{AP-TS}$  to be  $\overline{\gamma}_1$ , then  $\text{SNR}_{HL-TS}$  should be set to  $\overline{\gamma}_1 + \Delta\gamma_1$ . Similarly, if the average  $\text{INR}_{BS-TS}$  is set to be  $\overline{\gamma}_2$ , then  $\text{INR}_{BS-HL}$  should be set to  $\overline{\gamma}_2 + \Delta\gamma_2$ . The modulation scheme employed by BS is BPSK. As can be seen in Fig. 10, the proposed method achieves higher transmission rate than the other schemes regardless of the value of  $R_a$ . This is because HL can reliably decode interference from BS with measured CSI.

Fig. 11 shows the transmission rate versus the number of total antennas. As can be seen in this figure, a similar tendency to simulation results is obtained. This means that

Fig. 10. Transmission rate versus  $T_D/T_P$  using measured channel data.

Fig. 11. Transmission rate versus the number of total antennas using measured channel data.

the heterogeneous pathloss condition in Fig. 6 matches well with the measured data. We confirm that the proposed scheme achieves higher transmission rate than Method (C) regardless of the number of total antennas. Moreover, improvement on transmission rate by the proposed method compared to Method (C) is higher than that of the simulation result. Although the transmission rate of the proposed scheme is smaller than that of Method (B) when the SIR is -15 dB, the proposed method obtains much higher transmission rate than Method (B), when the SIR is 0 dB. From these results, we can conclude that the proposed scheme is effective in a practical setting with a cellular-based primary system and a short-range secondary system.

## V. CONCLUSIONS

This paper proposed an interference cancellation scheme by using the concept of distributed array in order to achieve coexistence between a FDD-based primary system and a secondary system. Our scheme exploits the periodic training

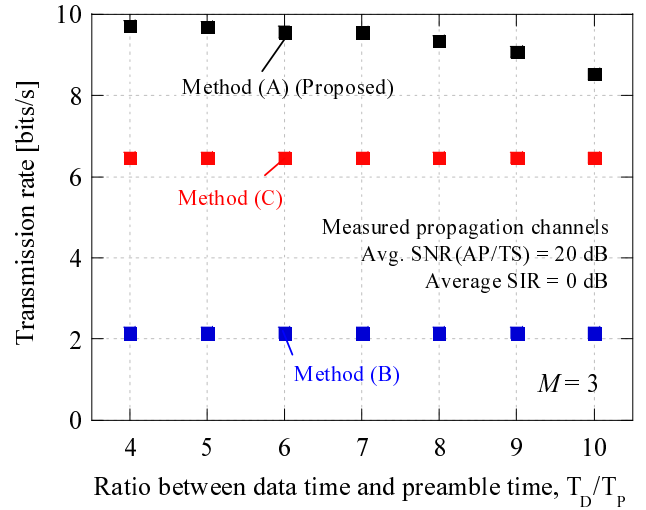
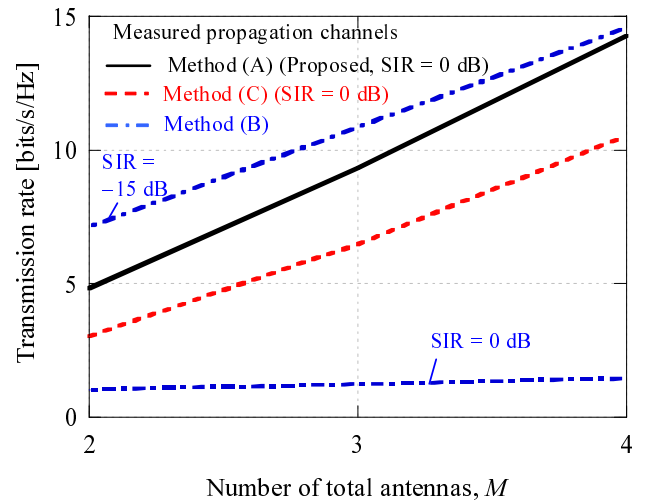
signals that are transmitted for synchronization in FDD–TDMA–based cellular systems. In such a way, an efficient interference cancellation is realized even if the signals whose number exceeds the degree of freedom of the array arrives at TS. Moreover, we introduced *interference compression* in order to enable transfer of interference–related information via the short training periods.

We have evaluated the proposed method by computer simulation and compared it with reference schemes. The results show that, under heterogeneous path loss conditions, the proposed method with  $M - 1$  antennas plus the helper with one antenna outperforms the scheme in which the terminal has  $M$  antennas and uses zero–forcing for interference cancellation. We have also presented results that are based on measured data in an actual outdoor environment by considering cellular-based primary system and a short–range secondary system, where performance benefits of the proposed method have been confirmed.

The proposed scheme is applicable not only to cognitive radio systems but also to conventional multi-cell systems. The interference from neighboring cells can be cancelled by using the relay stations or multiple terminal stations. The heterogeneous cellular systems consisting of macro, pico and femto cells are good target to apply the proposed scheme.

#### ACKNOWLEDGEMENTS

The part of this work is supported by JSPS KAKENHI, Grant-in-Aid for Young Scientists (B) 22760272.

#### REFERENCES

- [1] S. Haykin, "Cognitive radio: brain-empowered wireless communications," *IEEE J. Sel. Areas Commun.*, vol. 23, no.2, pp. 201-202, Feb. 2005.
- [2] J. Mitola III, "Cognitive radio for flexible mobile multimedia communications", in *Proc. 6th International Workshop Mobile Multimedia Commun. (MoMuC)*, pp.3-10, Nov. 1999.
- [3] X.Jing, S.Mau, D. Raychaudhuri, R.Matyas, "Reactive cognitive radio algorithms for Co-existence between IEEE 802.11b and 802.16a networks," *IEEE Global Telecommun. Conf. (GLOBECOM '05)*, vol. 5, pp. 2465-2469, Nov./Dec., 2005.
- [4] K. Nishimori, H. Yomo, P. Popovski, Y. Takatori, R. Prasad, and S. Kubota, "Distributed Interference Cancellation for Dynamic Spectrum Sharing," in *Proc. IEEE International Conf. ICC2008*, pp. 3044-3049, May 2008.
- [5] A. A. M. Saleh, A. J. Rustako, and R. S. Roman, "Distributed antennas for indoor radio communications," *IEEE Trans. Commun.*, vol. 35, pp. 1245-1251, Dec. 1987.
- [6] M. V. Clark, et al., "Distributed versus centralized antenna arrays in broadband wireless networks," in *Proc. IEEE Veh. Technol. Conf.*, pp. 33-37, May 2001.
- [7] L. Dai, S. Zho, and Y. Yao, "Capacity analysis in CDMA distributed antenna systems," *IEEE Trans. Wireless Commun.*, vol. 4, no. 6, pp. 2613-2620, Nov. 2006.
- [8] W. Roh and A. Paulraj, "Outage performance of the distributed antenna systems in a composite fading channel," in *Proc. IEEE Veh. Technol. Conf.*, pp. 1520-1524, Sept. 2002.
- [9] R. Dabora, I. Maric and A. Goldsmith, "Interference forwarding in multiuser networks," in *Proc. IEEE GlobeCom*.
- [10] I. Maric R. Dabora, and A. Goldsmith, "On the capacity of the interference channel with relay," in *Proc. IEEE International Symp. Inf. Theory (ISIT) 2008*.
- [11] P. Stuckmann, *The GSM Evolution: Mobile Packet Data Services*, WILEY Publishers, 2003.
- [12] K. Nishimori, R. D. Taranto, H. Yomo, P. Popovski, Y. Takatori, R. Prasad, and S. Kubota, "Spatial opportunity for cognitive radio systems with heterogeneous path loss conditions," in *Proc. IEEE 65th Veh. Technol. Conf. (VTC2007-Spring)*, Dublin, Ireland, Apr. 2007.
- [13] A. Urie, M. Stretton and C. Mourot, "An advanced TDMA mobile access system for UMTS," *IEEE Personal Commun.*, vol. 2, pp. 38-47, Feb. 1995.
- [14] J. Mitola III and G. Q. Maguire, Jr., "Cognitive radio: Making software radios more personal," *IEEE Pers. Commun.*, vol. 6, no. 4, pp. 13-18, Aug. 1999.
- [15] T. Suzuki, K. Kashiki, and A. Yamaguchi, "Heterogeneous wireless networks for reliable communications," *PIMRC 2009, Workshop 5, First International Workshop Cognitive Wireless Cloud Netw.*, no. 4, Sept. 2009.
- [16] G. L. Stuber, et al., "Broadband MIMO-OFDM Wireless Communications," in *Proc. IEEE*, vol. 92, pp. 271-294, Feb. 2004.
- [17] F. Adachi, H. Tomeba, and Kazuki Takeda, "Frequency-domain equalization for broadband single-carrier multiple access," *IEICE Trans. Commun.*, vol. E92-B, no. 5, pp. 1441-1456, May 2009.
- [18] R. A. Monzingo and T. W. Miller, *Introduction to Adaptive Array*, John Wiley & Sons, NY, 1980.
- [19] R. U. Nabar, H. Bolcskei, and F. W. Kneubuhler, "Fading relay channels: Performance limits and space-time signal design," *IEEE J-SAC*, vol. 22, no. 6, pp. 1099-1109, 2004.
- [20] J. N. Laneman, D. N. C. Tse, and G. W. Wornell, "Cooperative diversity in wireless networks: Efficient protocols and outage behavior," *IEEE Trans. Inf. Theory*, vol. 50, no. 12, pp. 3062-3080, Dec. 2004.
- [21] K. Yamamoto, H. Maruyama, T. Shimizu, H. Murata, and S. Yoshida, "Spectral efficiency of fundamental cooperative relaying in interference-limited environments," *IEICE Trans. Commun.*, vol. E91-B, pp. 2674-2682, no. 8, 2008.
- [22] A. Paulraj, R. Nabar D. Gore, *Introduction to Space-Time Wireless Communications*, Cambridge University Press, 2003.
- [23] J. B. Anderson, "Array gain and capacity for known random channels with multiple element arrays at both ends," *IEEE J. Sel. Areas Commun.*, vol. 18, pp. 2172-2178, Nov. 2000.
- [24] IEEE802.11.a, "High speed physical layer (PHY) in 5 GHz band," 1999.
- [25] G. A. Neonakis and R. Tafazolli, "On the relaying capability of next-generation GSM cellular networks," *IEEE Personal Commun.*, vol. 8, pp. 40-47, Feb. 2001.
- [26] S. R. Saunders, *Antenna and Propagation for Wireless Communication System*, John Wiley & Sons, NY, 1999.
- [27] S. T. Chung and A. J. Goldsmith "Degrees of Freedom in Adaptive Modulation: A Unified View," *IEEE Trans. Commun.*, vol. 49, pp. 1561-1571, no. 9, Sept. 2001.
- [28] S. Ichitsubo, et al., "2GHz-Band propagation loss prediction in urban areas; antenna heights ranging from ground to building roof," *IEICE Technical Report, A-P 96-15*, May 1996.
- [29] J. J. van de Beek, O. Edfors, M. Sandell, S. K. Wilson, P. O. Borjesson, "On channel estimation in OFDM systems," in *Proc. Veh. Technol. Conf.*, vol. 2, pp. 815-819, July 1995.



**Kentaro Nishimori** received the B.E., M.E. and Ph D. degrees in electrical and computer engineering from Nagoya Institute of Technology, Nagoya, Japan in 1994, 1996 and 2003, respectively. In 1996, he joined the NTT Wireless Systems Laboratories, Nippon Telegraph and Telephone Corporation (NTT), in Japan. He was senior research engineer on NTT Network Innovation Laboratories. He is now associate professor in Niigata University. He was a visiting researcher at the Center for Teleinfrastructure (CTIF), Aalborg University, Aalborg, Denmark from Feb. 2006 to Jan. 2007. He was an Associate Editor for the Transactions on Communications for the IEICE Communications Society from May 2007 to May 2010 and Assistant Secretary of Technical Committee on Antennas and Propagation of IEICE from June 2008 to May 2010. He received the Young Engineers Award from the IEICE of Japan in 2001, Young Engineer Award from IEEE AP-S Japan Chapter in 2001, Best Paper Award of Software Radio Society in 2007 and Distinguished Service Award from the IEICE Communications Society in 2005, 2008 and 2010. His main interests are spatial signal processing including MIMO systems and interference management techniques in heterogeneous networks. He is a member of IEEE.



**Hiroyuki Yomo** received B.S., M.S., and Ph.D. degrees in communication engineering from Osaka University, Japan, in 1997, 1999 and 2002, respectively. From April 2002 to March 2004, he was a Post-doctoral Fellow at Aalborg University, Denmark. From April 2004 to September 2004, he was at NEC Corporation, Japan. In October 2004, he joined Aalborg University, Denmark, as an Assistant Research Professor, and worked as an Associate Professor from February 2006 to March 2008. From April 2008 to March 2010, he was a senior re-

searcher at ATR, Japan. Since April 2010, he has been an Associate Professor at Kansai University, Japan. He is also affiliated with Aalborg University as an Assigned Associate Professor and with ATR as a guest researcher. He received the 2010 Funai Academic Award from Funai Foundation for Information Technology. He has received several best paper awards, including the one at IEEE Globecom 2009. His main research interests are access technologies, radio resource management, and link-layer techniques in the area of ad hoc/vehicular network, wireless LAN, cellular system, cognitive radio, and wireless network coding. He is an editor of IEEE Communications Letters.



**Petar Popovski** received the Dipl.-Ing. in electrical engineering and Magister Ing. in communication engineering from Sts. Cyril and Methodius University, Skopje, Macedonia, in 1997 and 2000, respectively and Ph. D. from Aalborg University, Denmark, in 2004. He was Assistant Professor at Aalborg University from 2004 to 2009. From 2008 to 2009 he held part-time position as a wireless architect at Oticon A/S. Since 2009 he is an Associate Professor at Aalborg University. He has more than 100 publications in journals, conference proceedings and books

and has more than 25 patents and patent applications. He has received the Young Elite Researcher award from the Danish Free Research Council. He has received several best paper awards, including the ones from IEEE Globecom, IEEE Communication Theory Workshop and CROWNCOM. Dr. Popovski serves on the editorial board of several journals, including IEEE Transactions on Wireless Communications and IEEE Communications Letters. His research interests are in the broad area of wireless communication and networking, information theory and protocol design.