



Aalborg Universitet

AALBORG UNIVERSITY
DENMARK

Secondary control for voltage unbalance compensation in an islanded microgrid

Savaghebi, Mehdi; Guerrero, Josep M.; Jalilian, Alireza ; Vasquez, Juan Carlos

Published in:

Proceedings of the 2nd IEEE International Conference on Smart Grid Communications, SmartGridComm 2011

DOI (link to publication from Publisher):

[10.1109/SmartGridComm.2011.6102373](https://doi.org/10.1109/SmartGridComm.2011.6102373)

Publication date:

2011

Document Version

Early version, also known as pre-print

[Link to publication from Aalborg University](#)

Citation for published version (APA):

Savaghebi, M., Guerrero, J. M., Jalilian, A., & Vasquez, J. C. (2011). Secondary control for voltage unbalance compensation in an islanded microgrid. In *Proceedings of the 2nd IEEE International Conference on Smart Grid Communications, SmartGridComm 2011* (pp. 499-504). IEEE Press.
<https://doi.org/10.1109/SmartGridComm.2011.6102373>

General rights

Copyright and moral rights for the publications made accessible in the public portal are retained by the authors and/or other copyright owners and it is a condition of accessing publications that users recognise and abide by the legal requirements associated with these rights.

- ? Users may download and print one copy of any publication from the public portal for the purpose of private study or research.
- ? You may not further distribute the material or use it for any profit-making activity or commercial gain
- ? You may freely distribute the URL identifying the publication in the public portal ?

Take down policy

If you believe that this document breaches copyright please contact us at vbn@aub.aau.dk providing details, and we will remove access to the work immediately and investigate your claim.

Secondary Control for Voltage Unbalance Compensation in an Islanded Microgrid

Mehdi Savaghebi¹, Josep M. Guerrero^{2,3}, Alireza Jalilian¹, and Juan C. Vasquez³

¹Center of Excellence for Power System Automation and Operation, Iran University of Science and Technology, Iran

²Department of Automatic Control and Industrial Informatics, Technical University of Catalonia, Spain

³Department of Energy Technology, Aalborg University, Denmark

savaghebi@iust.ac.ir, joz@et.aau.dk, jalilian@iust.ac.ir, juq@et.aau.dk

Abstract—In this paper, the concept of secondary control is applied for voltage unbalance compensation in an islanded microgrid. The aim of the proposed control approach is to enhance the voltage quality at the point of common coupling (PCC). Unbalance compensation is achieved by proper control of distributed generators (DGs). The DGs control structure mainly consists of active and reactive power controllers, virtual impedance loop and voltage and current proportional-resonant controllers. Simulation results are presented for different cases. The results show the effectiveness of the proposed approach in the compensation of voltage unbalance.

Keywords—distributed generation; microgrid; secondary control; voltage unbalance compensation

I. INTRODUCTION

Distributed Generators (DGs) may be connected individually to the utility grid or be integrated to form a local grid which is called microgrid (MG). The MG can operate in grid-connected (connected to the utility grid) or islanded (isolated from the utility grid) modes [1].

DGs often consist of a prime mover connected through an interface converter (e.g. an inverter in case of dc-to-ac conversion) to the power distribution system (microgrid or utility grid). The main role of this inverter is to control voltage amplitude and phase angle in order to inject the active and reactive power. In addition, compensation of power quality problems, such as voltage unbalance, can be achieved through proper control strategies.

In [2]-[8], some approaches are presented to apply the DG for power quality compensation purposes. The control method presented in [2] and [3] is based on using a two-inverter structure connecting one in shunt and the other in series to the grid, like a series-parallel active power filter [4]. The main role of the shunt inverter is to control active and reactive power flow, while the series inverter balances the line currents and the voltages at sensitive load terminals, in spite of grid voltage unbalance. This is done by injecting negative sequence voltage. Thus, two inverters are necessary for the power injection and unbalance compensation.

Another method based on injecting negative sequence current by the DG to compensate voltage unbalance is proposed in [5]. As a result, line currents become balanced in spite of the presence of unbalance loads. However, in the case of severe load unbalances (e.g. one-phase disconnection of a

three-phase load or connection of a single-phase load), the amplitude of the injected current can be very high. Thus, compensation will occupy a large amount of the capacity and may limit the DG capability to supply active and reactive power.

A synchronous (dq) reference frame control method for compensation of voltage unbalance in a microgrid is presented in [6]. In this method DGs are controlled to provide a negative sequence conductance. Negative sequence reactive power is used for compensation effort sharing. In [6] the compensation reference is injected to the output of the voltage controller. As explained in [7], this place of compensation reference injection is not proper, since the voltage controller considers this reference as a disturbance. Thus, it is proposed in [7] to inject the compensation reference before the voltage controller. Also, the negative sequence reactive power definition of [6] is modified. Furthermore, the control system of [7] is completely designed in stationary ($\alpha\beta$) reference frame. A similar control structure is applied in [8] for a grid-connected DG. In [8] a PI controller is used to follow the reference of voltage unbalance factor.

The methods proposed in [6]-[8] are designed for compensation of voltage unbalance compensation at the DG terminal, while usually the power quality at the point of common coupling (PCC) is the main concern.

In this paper the concept of secondary control [9] is extended to compensate the voltage unbalance at PCC in an islanded microgrid. A PI controller is used to generate the reference of unbalance compensation for the DGs of the microgrid. This reference is transmitted by a low band-width communication link. The details are as follows.

II. PROPOSED SECONDARY CONTROL-BASED UNBALANCE COMPENSATION METHOD

A hierarchical structure is presented in [9] for control of microgrids. In this control structure three control levels are considered: primary control, secondary control, and tertiary control.

Primary control level adjusts the frequency and amplitude of the DG output voltage reference. This reference is provided to the inner current and voltage control loops. Droop controllers are the core parts of primary control level. These controllers are responsible for DG active and reactive power control.

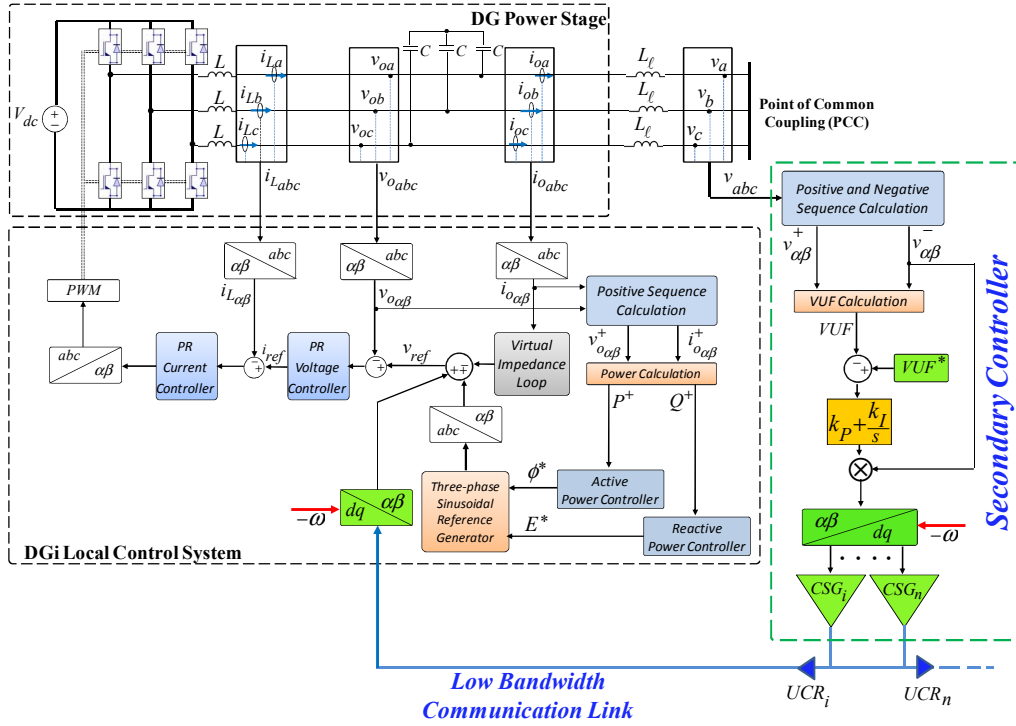

Fig. 1. Secondary controller and DG power stage and control system

The secondary controller ensures that the frequency and voltage deviations are regulated toward zero after every change of load or generation inside the microgrid. Also, it compensates the frequency and amplitude deviations caused by droop controllers. Secondary controller sends the control references to the DGs of microgrid through low bandwidth communication links. The tertiary control level ensures that the microgrid is injecting desired active and reactive power in grid-connected operating mode.

In this paper, the concept of secondary control is applied for voltage unbalance compensation. Fig. 1 shows the control structure of the secondary controller. Also, the power stage and the local control system of each microgrid DG are shown in this Fig. The DG power stage consists of a DC prime mover, an inverter and a LC filter. Each DG is connected to PCC through an inductive distribution line. The details of the DG control system are addressed in the next Section. The details of voltage unbalance compensation by the secondary controller are as follows.

According to Fig. 1, three-phase PCC voltage is measured and its positive and negative sequences are extracted as explained in [10], [11]. Then, PCC “Voltage Unbalance Factor: VUF ” is calculated. VUF which is considered as the index of voltage unbalance is calculated as follows:

$$VUF = \frac{v_{rms}^-}{v_{rms}^+} \cdot 100 \quad (1)$$

where v_{rms}^- and v_{rms}^+ are the “rms” values of negative and positive sequences of voltage, respectively.

Afterwards, the calculated VUF is compared with the reference VUF^* and the error is fed to a proportional-integral (PI) controller. The output of the PI controller is multiplied by the negative sequence PCC voltage ($v_{\alpha\beta}^-$).

The resultant value is transformed to dq reference frame and multiplied by the “Compensation Sharing Gain: CSG ” to generate “Unbalance Compensation Reference: UCR ”. CSG_i determines the compensation effort of DG $_i$ ($i=1, \dots, n$). Some criteria can be considered for setting of CSG_i . For instance, it can be determined in proportion with the DG rating.

Finally, the compensation references are transmitted toward DGs through low bandwidth communication links. Low bandwidth communication is sufficient since UCR s are dc values in dq reference frame.

III. DG INVERTER CONTROL STRATEGY

As shown in Fig. 1, the DG proportional-resonant (PR) voltage controller follows the references generated by power controllers, virtual impedance loop, and secondary controller and generates the reference for the PR current controller. The output of the current controller is transformed back to the abc frame to provide the reference three-phase voltage for the pulse width modulator (PWM). Finally, the PWM block controls the switching of the inverter based on this reference. More details are presented in the following Subsections.

A. Active and Reactive Power Control

Assuming a three-phase DG which is connected to the electrical network through a mainly inductive distribution line, P and Q can be approximated as follows [12], [13]:

$$P = 3 \cdot \frac{EV}{X} \phi \quad (2)$$

$$Q = 3 \cdot \frac{V}{X} (E - V) \quad (3)$$

Thus, active and reactive powers can be controlled by the DG output voltage phase angle and amplitude, respectively. According to this, the following droop characteristics are considered for the positive sequence active and reactive power sharing among DGs of an islanded microgrid.

$$\phi^* = \phi_0 - (m_P P^+ + m_I \int P^+ dt) \quad (4)$$

$$E^* = E_0 - n_P Q^+ \quad (5)$$

- E_0 : rated voltage amplitude
- ϕ_0 : rated phase angle ($\int \omega_0 dt = \omega_0 t$)
- ω_0 : rated angular frequency
- P^+ : positive sequence active powers
- Q^+ : positive sequence reactive power
- m_P : active power proportional coefficient
- m_I : active power integral coefficient
- n_P : reactive power proportional coefficient
- E^* : voltage amplitude reference
- ϕ^* : voltage phase angle reference

In fact, equation (4) acts as a proportional-derivative controller for frequency. The derivative term (m_P) helps to improve the dynamic behavior of the power control [12].

It is noteworthy that according to the equations (4) and (5), no integral term is considered for voltage frequency and amplitude control. If the microgrid operates in islanded mode (the case considered in this paper) the use of pure integrators is not allowed; since, the total load will not coincide with the total injected power, and it leads to instability [9],[14].

As it can be seen in Fig. 1, E^* and ϕ^* are used to generate the three phase reference voltages of the inverter. These voltages are positive-sequence components; thus positive sequence powers (P^+ and Q^+) are used in equations (4) and (5). The details of power calculation are provided in the next Subsection.

B. Power Calculation

According to Fig. 1, in order to calculate positive sequence powers, at first DG three-phase output voltage and current (v_{oabc} and i_{oabc} , respectively) are measured and transformed to $\alpha\beta$ frame. Then, positive sequence of output voltage ($v_{o\alpha\beta}^+$) and current ($i_{o\alpha\beta}^+$) are extracted. In the next step, the instantaneous values of positive sequence active and reactive powers are calculated as follow [15]:

$$p^+ = v_{\alpha}^+ i_{\alpha}^+ + v_{\beta}^+ i_{\beta}^+ \quad (6)$$

$$q^+ = v_{\beta}^+ i_{\alpha}^+ - v_{\alpha}^+ i_{\beta}^+ \quad (7)$$

Then, the dc components of p^+ and q^+ (P^+ , Q^+) are extracted using first-order low pass filters. In the present paper, cut-off frequencies of these filters are set to 1Hz.

C. Virtual Impedance Loop

Addition of the virtual resistance control loop makes the oscillations of the system more damped [12]. Also, virtual inductance is considered to ensure the decoupling of P and Q . Thus, virtual impedance makes the droop controllers more stable [16].

The virtual impedance can be achieved as shown in Fig.2, where R_v and L_v are the virtual resistance and inductance values, respectively. The basic idea of this scheme is presented in [17]. Here, the scheme of [17] is modified by adding the positive sequence extraction block to achieve “selective” virtual impedance. Thus, negative sequence current will not pass through virtual impedance. This way, the increase of DG output voltage unbalance due to the negative sequence voltage drop on the virtual impedance will be avoided.

D. Voltage and Current Controllers

Proportional-resonant (PR) controllers are often used in the stationary reference frame control systems [18]. In this paper, PR voltage and current controllers are as follow:

$$G_V(s) = k_{pV} + \frac{2k_{rV}\omega_{cV}s}{s^2 + 2\omega_{cV}s + \omega^2} \quad (8)$$

$$G_I(s) = k_{pI} + \frac{2k_{rI}\omega_{cI}s}{s^2 + 2\omega_{cI}s + \omega^2} \quad (9)$$

where, k_{pV} (k_{pI}) and k_{rV} (k_{rI}) are the proportional and resonant coefficients of the voltage (current) controller, respectively. Also, ω_{cV} and ω_{cI} represent the voltage and current controller cut-off frequencies, respectively.

The Bode diagrams of voltage and current controllers using the parameters listed in Table I are depicted in Fig. 3. As can be seen, the gains of voltage and current controllers at resonant frequency are high enough to ensure small tracking errors.

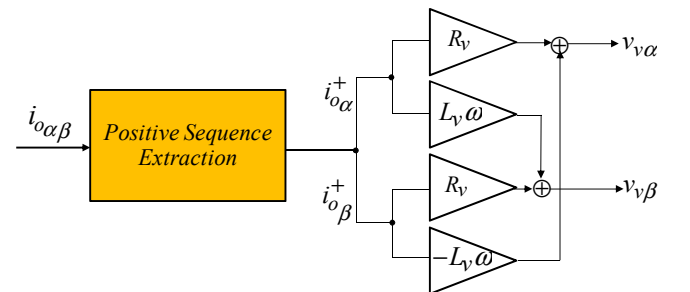

Fig. 2. Selective virtual impedance

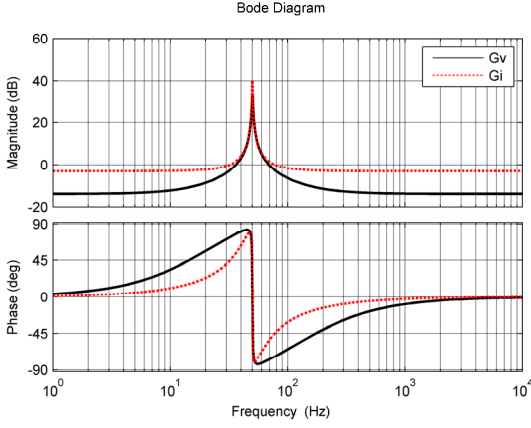

Fig. 3. Voltage and current controllers Bode diagrams

IV. SIMULATION RESULTS

The islanded microgrid of Fig. 4 is considered as the test system. This microgrid includes two DGs with power stage and control system shown in Fig. 1. Control system and power stage parameters are listed in Tables I and II, respectively. Switching frequency of the DGs inverters is set to 10 kHz. As seen in Fig. 4, a single-phase load is connected between phases “a” and “b” to create voltage unbalance. A balanced load is also connected to PCC. The switch shown in this Fig. is closed after DGs synchronization to form the microgrid. The synchronization method is explained in [9].

The communication delays of UCR transmission are $\Delta t_{d1} = \Delta t_{d2} = 2$ sampling periods. Fig. 5 shows VUF values at PCC and DGs terminal. Unbalance compensation is activated at $t=2$ sec. VUF^* is set to 0.5%. As shown, VUF of PCC follows the reference value, properly. Also, it can be seen that the improvement of PCC voltage quality is achieved by making the DGs output voltage unbalanced. It can be more clearly seen in Fig. 6. This Fig. shows three-phase voltages at PCC and DGs terminal before and after compensation.

Sharing of P^+ and Q^+ is shown in Figs. 7(a) and 7(b), respectively. As seen, in spite of asymmetrical distribution lines ($L_{l1} = 3.6mH, L_{l2} = 1.8mH$), active and reactive powers are shared properly between the DGs and compensation doesn't interfere with the operation of the power controllers. In this case, CSG_1 and CSG_2 are both set to 1; thus, the DGs compensation effort is equal. It leads to the same amount of after-compensation unbalance at DGs terminal.

A. Uneven Compensation Effort Sharing

In this case, $CSG_1=1$ and $CSG_2=1.25$ to simulate uneven compensation effort sharing. VUF s at PCC and DGs terminal are depicted in Fig. 8. It can be observed that the VUF^* is tracked well. Also, DG2 output voltage has become more unbalanced due to more compensation effort.

The active and reactive power sharing in this case is shown in Figs. 9(a) and 9(b), respectively. As seen, different CSG s lead to noticeable transient change of powers. Also,

sharing of after-compensation reactive powers is not as well as previous case.

B. Different Communication Lines Delays

In this case, both CSG s are set to 1; but, different communication delays are considered ($\Delta t_{d1}=2$ and $\Delta t_{d2}=8$ sampling periods). As depicted in Fig. 10, VUF^* is followed properly. Also, larger Δt_{d1} leads to slightly lower after-compensation VUF for DG1. In the other words, DG1 compensation effort is slightly lower.

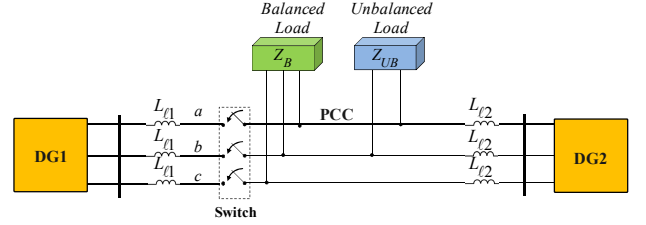

Fig. 4. Test system for simulation studies

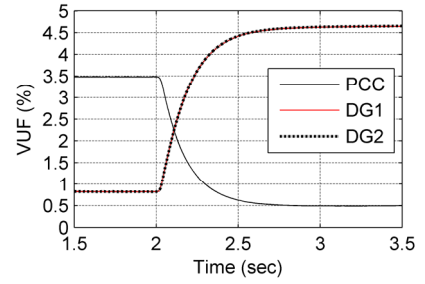

Fig. 5. VUF at PCC and DGs terminal

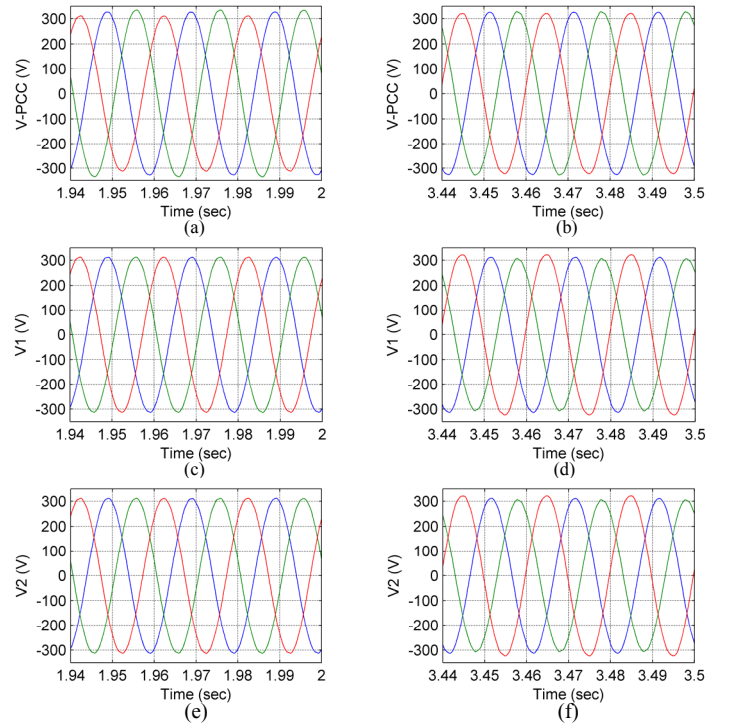
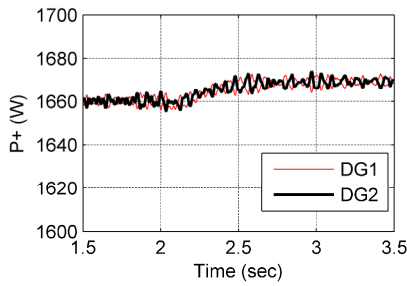
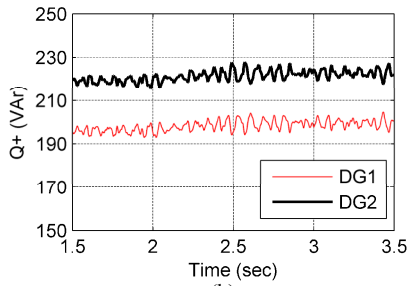

Fig. 6. Three-phase voltage waveforms (a) PCC-before comp. (b) PCC-after comp. (c) DG1-before comp. (d) DG1-after comp. (e) DG2-before comp. (f) DG2-after comp.

Figs. 11(a) and 11(b) show the power sharing of this case. As seen, oscillations of after-compensation active and reactive powers are larger comparing equal Δt_d case (Fig. 7).



(a)



(b)

Fig. 7. Power sharing: (a) active power, (b) reactive power

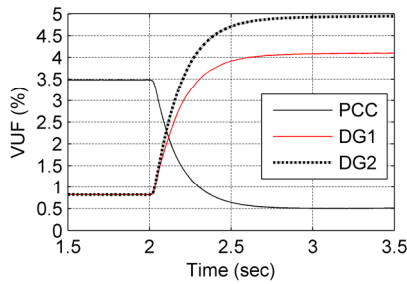
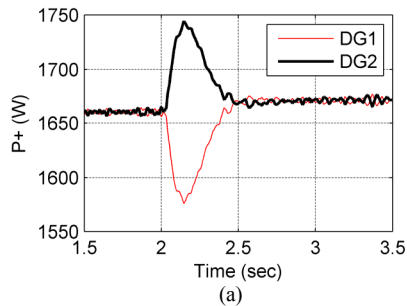
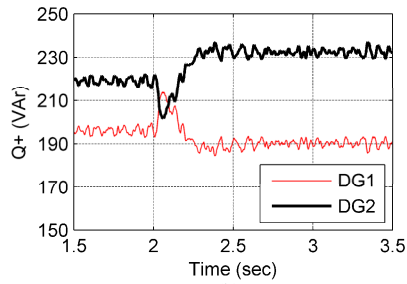

Fig. 8. VUF at PCC and DGs terminal ($CSG_1=1, CSG_2=1.25$)



(a)



(b)

Fig. 9. Power sharing: (a) active power, (b) reactive power ($CSG_1=1, CSG_2=1.25$)

C. Communication Link Failure

In this case, $\Delta t_{d1} = \Delta t_{d2} = 2$ sampling periods and $CSG_1 = CSG_2 = 1$. But, it is assumed that communication link to DG1 fails at $t=3.5$ sec. As seen in Fig. 12, after failure of DG1 communication link, VUF^* is still tracked well; DG1 VUF returns to before-compensation value (zero compensation effort). So, DG2 covers the absence of DG1 in unbalance compensation; thus, its VUF increases.

Figs. 13(a) and 13(b) show the power sharing in this case. As seen, in addition to noticeable change of power in transient state, the steady-state reactive powers are not shared well.

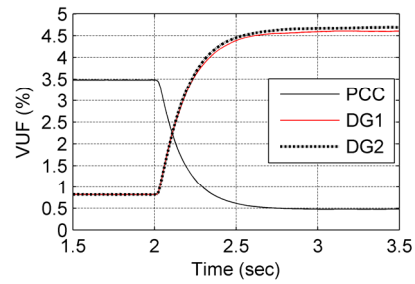
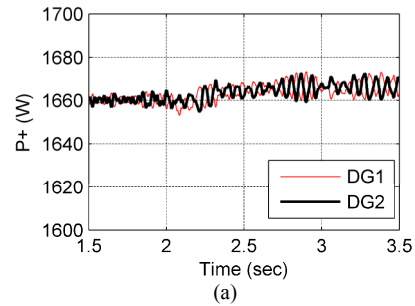
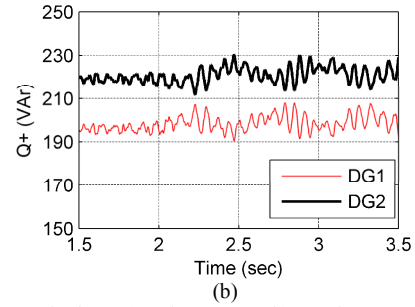

Fig. 10. VUF at PCC and DGs terminal (different Δt_d)



(a)



(b)

Fig. 11. Power sharing: (a) active power, (b) reactive power (different Δt_d)

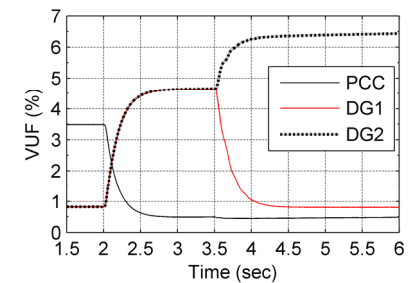

Fig. 12. VUF at PCC and DGs terminal (DG1 communication link failure at $t=3.5$ sec)

TABLE I. CONTROL SYSTEM PARAMETERS

Power Controllers					Virtual Impedance		Voltage Controller			Current Controller			Secondary PI Controller	
m_P	m_I	n_P	E_0	ω_0	R_V (Ω)	L_V (mH)	k_{pV}	k_{rV}	ω_{cV}	k_{pI}	k_{rI}	ω_{cI}	k_P	k_I
0.00003	0.0003	0.02	330	$2\pi*50$	1	4	0.2	50	2	0.7	100	1	0.75	0.2

TABLE II. POWER STAGE PARAMETERS

DG prime mover	inverter filter inductance	inverter filter capacitance	DG1 distribution line	DG2 distribution line	Unbalanced load	Balanced load
V_{dc} (V)	L (mH)	C (μF)	$L_{\ell 1}$ (mH)	$L_{\ell 2}$ (mH)	Z_{UB} (Ω)	Z_B (Ω)
650	1.8	25	3.6	1.8	550	$50+j6.3$

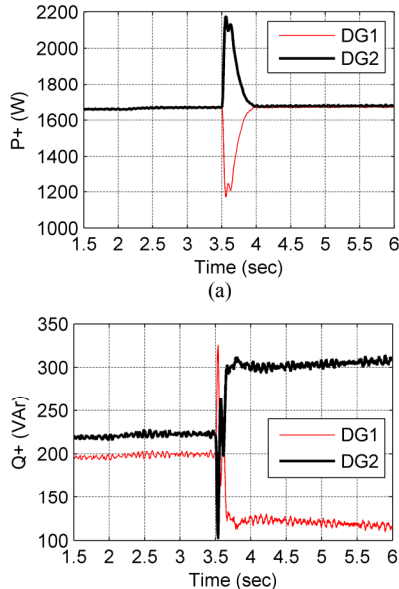
Fig. 13. Power sharing: (a) active power, (b) reactive power (DG1 communication link failure at $t=3.5$ sec)

V. CONCLUSIONS

A secondary control approach for compensation of PCC voltage unbalance in an islanded microgrid is presented. The compensation is achieved by proper control of DGs interface converter. Compensation references are transmitted through a low bandwidth communication link from the central secondary controller to local DGs controllers.

The results show that the PCC voltage unbalance is compensated to the desired value in different simulation cases.

REFERENCES

- [1] S. B. Patra, "Techniques for developing reliability-oriented optimal microgrid architectures," *PhD. Diss.*, New Mexico State University, May 2007.
- [2] Y. Li, D. M. Vilathgamuwa, and P. C. Loh, "Microgrid power quality enhancement using a three-phase four-wire grid-interfacing compensator," *IEEE Trans. Ind. Appl.*, vol. 41, no. 6, pp. 1707-1719, Nov./Dec. 2005.
- [3] Y. Li, D. M. Vilathgamuwa, and P. C. Loh, "A grid-interfacing power quality compensator for three-phase three-wire microgrid applications," *IEEE Trans. Pow. Elec.*, vol. 21, no. 4, pp. 1021-1031, Jul. 2006.
- [4] S. A. Oliveira da Silva, P. F. Donoso-Garcia, P. Cabaleiro-Cortizo, and P. F. Seixas, "A three-phase line-interactive UPS system implementation with series-parallel active power-line conditioning capabilities," *IEEE Trans. Ind. Appl.*, vol. 38, no. 6, pp. 1581-1590, Nov./Dec. 2002.
- [5] M. Hojo, Y. Iwase, T. Funabashi, and Y. Ueda, "A method for three-phase balancing in microgrid by photovoltaic generation systems," *In Proc. Pow. Elec. and Motion Cont. Conf. (EPE-PEMC)*, 2008.
- [6] P. T. Cheng, C. Chen, T. L. Lee and S. Y. Kuo, "A cooperative imbalance compensation method for distributed-generation interface converters," *IEEE Trans. Ind. Appl.*, vol. 45, no. 2, pp. 805-815, Mar./Apr. 2009.
- [7] M. Savaghebi, J. M. Guerrero, A. Jalilian, and J. C. Vasquez, "Experimental evaluation of voltage unbalance compensation in an islanded microgrid," *in Proc. 20th IEEE Int. Symp. on Ind. Elec. (ISIE 2011)*, Jun. 2011.
- [8] M. Savaghebi, A. Jalilian, J. C. Vasquez, J. M. Guerrero, and R. Teodorescu, "Distributed generator with voltage unbalance compensation capability," *in Proc. 25th Int. Pow. Sys. Conf. (PSC 2010)*, Nov. 2010. (available online: www.psc-ir.com/ed10/10-E-PQA-1943.pdf).
- [9] J. M. Guerrero, J. C. Vasquez, J. Matas, L. G. de Vicuña, and M. Castilla, "Hierarchical control of droop-controlled AC and DC microgrids—a general approach toward standardization," *IEEE Trans. Ind. Elec.*, vol. 58, no. 1, pp. 158-172, Jan. 2011.
- [10] M. Ciobotaru, R. Teodorescu, and F. Blaabjerg, "A new single-phase PLL structure based on second order generalized integrator," *in Proc. Pow. Elec. Specialists Conf. (PESC)*, Oct. 2006.
- [11] P. Rodriguez, A. V. Timbus, R. Teodorescu, M. Liserre and F. Blaabjerg, "Flexible active power control of distributed power generation systems during grid faults," *IEEE Trans. Ind. Elec.*, vol. 54, no. 5, pp. 2583-2592, Oct. 2007.
- [12] J. M. Guerrero, J. Matas and L. G. de Vicuña, M. Castilla, and J. Miret, "Decentralized control for parallel operation of distributed generation inverters using resistive output impedance," *IEEE Trans. Ind. Elec.*, vol. 54, no. 2, pp. 994-1004, Apr. 2007.
- [13] E. Barklund, N. Pogaku, M. Prodanovic, C. H. Aramburo, and T. C. Green, "Energy management in autonomous microgrid using stability-constrained droop control of inverters," *IEEE Trans. Pow. Elec.*, vol. 23, no. 5, pp. 2346-2352, Sept. 2008.
- [14] Y. Li, D. M. Vilathgamuwa, and P. C. Loh, "Design, analysis, and real-time testing of a controller for multibus microgrid system," *IEEE Trans. Pow. Elec.*, vol. 19, no. 5, pp. 1195-1204, Sept. 2004.
- [15] H. Akagi, Y. Kanagawa, and A. Nabase, "Instantaneous reactive power compensator comprising switching devices without energy storage components," *IEEE Trans. Ind. Appl.*, vol. IA-20, no. 3, p. 625, May/Jun. 1984.
- [16] J. M. Guerrero, L. G. Vicuna, J. Matas, M. Castilla, and J. Miret, "Output impedance design of parallel-connected UPS inverters with wireless load sharing control," *IEEE Trans. Ind. Elec.*, vol. 52, no. 4, pp. 1126-1135, Aug. 2005.
- [17] J. He, and Y. W. Li "Analysis and design of interfacing inverter output virtual impedance in a low voltage microgrid," *in Proc. Energy Conv. Cong. and Exp. (ECCCE)*, Sept. 2010.
- [18] F. Blaabjerg, R. Teodorescu, M. Liserre, and A. V. Timbus, "Overview of control and grid synchronization for distributed power generation systems," *IEEE Trans. Ind. Elec.*, vol. 53, no. 5, pp. 1398-1409, Oct. 2006.