



Aalborg Universitet

AALBORG UNIVERSITY
DENMARK

Wideband Limit Study of a GaN Power Amplifier Using Two-Tone Measurements

Tafari, Felice Francesco; Sira, Daniel; Studsgaard Nielsen, Troels; Jensen, Ole Kiel; Larsen, Torben

Published in:
29th NORCHIP Conference

DOI (link to publication from Publisher):
[10.1109/NORCHIP.2011.6126706](https://doi.org/10.1109/NORCHIP.2011.6126706)

Publication date:
2011

Document Version
Early version, also known as pre-print

[Link to publication from Aalborg University](#)

Citation for published version (APA):

Tafari, F. F., Sira, D., Studsgaard Nielsen, T., Jensen, O. K., & Larsen, T. (2011). Wideband Limit Study of a GaN Power Amplifier Using Two-Tone Measurements. In *29th NORCHIP Conference* (pp. 1-4). IEEE Press. <https://doi.org/10.1109/NORCHIP.2011.6126706>

General rights

Copyright and moral rights for the publications made accessible in the public portal are retained by the authors and/or other copyright owners and it is a condition of accessing publications that users recognise and abide by the legal requirements associated with these rights.

- ? Users may download and print one copy of any publication from the public portal for the purpose of private study or research.
- ? You may not further distribute the material or use it for any profit-making activity or commercial gain
- ? You may freely distribute the URL identifying the publication in the public portal ?

Take down policy

If you believe that this document breaches copyright please contact us at vbn@aub.aau.dk providing details, and we will remove access to the work immediately and investigate your claim.

Wideband Limit Study of a GaN Power Amplifier Using Two-Tone Measurements

Felice Francesco Tafuri*, Daniel Sira*, Troels Studsgaard Nielsen[†], Ole Kiel Jensen* and Torben Larsen*

*Department of Electronic Systems, Aalborg University, Niels Jernes Vej 12, 9220 Aalborg, Denmark

E-mail: {fft, ds, okj, tl}@es.aau.dk

[†]Agilent Technologies Belgium, Wingepark 51, B-3110 Rotselaar, Belgium

E-mail: troels_nielsen@agilent.com

Abstract—This paper studies the wideband limit (WBL) of a GaN RF power amplifier (PA). The WBL study is achieved by a PA characterization using two-tone measurements. The characterization method allows to identify the dependency of PA memory effects (MEs) on the two-tone frequency spacing. PA memory effects (MEs) are measured using the opening in the AM/AM and AM/PM curves and they were found to be located in a limited range of tone spacings. The outcome of this characterization procedure is the identification of the PA wideband limit defined as the upper limit of the MEs frequency range. The most interesting phenomenon related to the WBL is that for all tone spacings beyond the WBL the AM/AM curves of the PA collapse to a quasi-static case, which is different from the static case. The presence of the wideband limit is not so evident from AM/PM curves, where the phase loop is not collapsing beyond WBL. The wideband limit is an important aspect of the DUT behaviour and can be used to improve the accuracy of the DUT behavioral model identifying its memory range.

I. INTRODUCTION

Nowadays the transition to 3G/4G mobile communication standards is in progress. This changeover brings a wider bandwidth to users at the price of more demanding requirements on the transmitter and consequently on the power amplifier (PA). The PA design has become very challenging due to the efficiency and linearity specifications imposed by the new standards. In order to comply with the efficiency-linearity trade-off, PAs can be designed aiming for high efficiency and then linearized using a linearization technique.

In the past decade, digital predistortion has been one of the most emphasized linearization techniques [1]. However, this technique is very sensitive to PA memory effects [2], and a dynamic predistorter performs considerably better when significant memory effects (MEs) are detected [1].

In order to design an effective dynamic predistorter, a PA behavioral model including memory effects is needed. The identification and validation of such a behavioral model requires a measurement procedure that characterizes PA dynamic nonlinearities. Characterization methods based on two-tone measurements have been used in the past, predominantly to measure the asymmetries in the intermodulation products observed in the PA response [3], [4].

In this paper a two-tone input signal is applied to the PA sweeping the frequency spacing of the two tones and the complex envelope of the PA response is measured acquiring the I and Q waveforms. From the measured PA response the

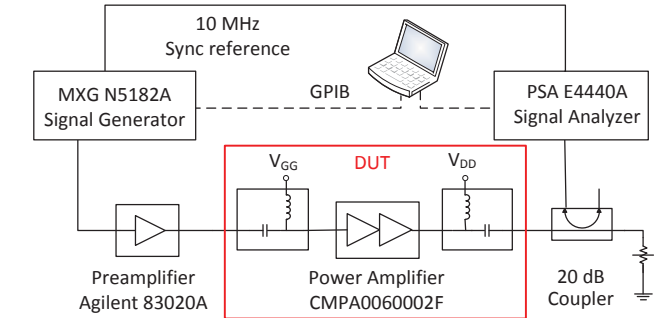

Fig. 1. Measurement set-up used for this paper. For PA biasing the external bias tees HP-11590B (at the input port) and HP-11612A (at the output port) have been used.

input-output voltage characteristic (AM/AM) and the phase deviation versus the input voltage (AM/PM) are obtained. The mapping of MEs versus the tone spacing is obtained from the analysis of the opening in the AM/AM and AM/PM curves. The memory effects mapping methodology presented in this paper was introduced in [5] to characterize a CMOS amplifier. In this article the method is applied to a GaN PA and further expanded to characterize the wideband limit of the PA.

II. TWO-TONE MEMORY EFFECTS CHARACTERIZATION

A. Measurement methodology

The measurement set-up used for this paper is shown in Fig. 1. The power amplifier is a Cree GaN PA with an output power of 35.7 dBm and a gain of 16.8 dB at 3 GHz. The Agilent signal generator and signal analyzer are controlled via a GPIB user interface. The device under test (DUT) is represented by the Cree GaN PA and the two bias tees at input and output port.

The input signal applied to the DUT was generated using the internal option for two-tone test of the signal generator and sweeping the tone spacing. The complex envelope of the two-tone signal can be represented as follows:

$$x(t) = A_R \sin(2\pi f_k t) + j A_I \sin(2\pi f_k t) \quad (1)$$

where k is the index representing the k^{th} tone spacing, A_R and A_I are the amplitude of the real part and the imaginary part of the complex envelope. The complex envelope of the applied

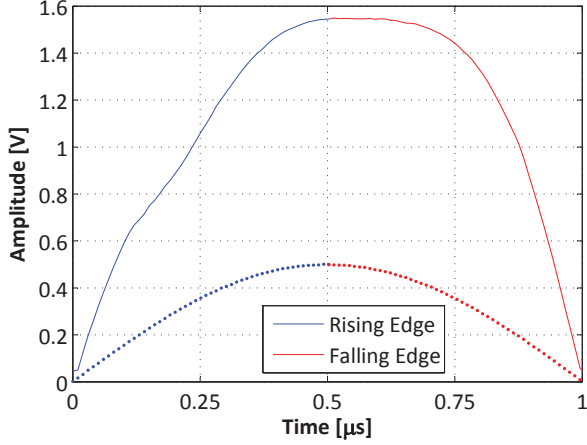

Fig. 2. Rising and falling edges of the amplitude of the measured PA input (dotted) and output (continuous) envelopes. The input signal is a two-tone signal with a tone spacing of 1 MHz.

two-tone signal is a complex sinusoid whose frequency f_k is half of the frequency spacing of the two tones. Eq. 1 can be expressed in polar form as follows:

$$x(t) = r(t) \cdot \exp[j\phi(t)] \quad (2)$$

$$r(t) = \sqrt{A_R^2 + A_I^2} \cdot |\sin(2\pi f_k t)| \quad (3)$$

$$\phi(t) = \frac{\pi}{2} - \frac{\pi}{2} \text{sgn}[\sin(2\pi f_k t)] + \arctan \frac{A_I}{A_R} \quad (4)$$

where $r(t)$ and $\phi(t)$ are the amplitude and phase of the two-tone complex envelope and they are expressed in Eq. 3-4 as functions of f_k , A_R and A_I .

The preamplifier has a gain of 38.6 dB at 3 GHz and for all the two-tone measurements, the power amplifier was driven with an average input power of -13 dBm from the signal generator which leads to 8 dB compression in the PA gain at the peak of the envelope. The I and Q components of the PA input and output signal were measured separately for each of the tone spacings using a 102 MHz sample rate. The PA input was measured at the output of the preamplifier and it was time-aligned to the PA output using a cross-correlation of the signals. The RF carrier was fixed at 3 GHz. The GaN PA was biased with 28 V of V_{DD} and 100 mA of I_D .

B. Characterization of Memory Effects

Due to the presence of MEs, an asymmetry between the rising and falling edges of the absolute value of the complex envelope of the PA response (Fig. 2) can be observed. This phenomenon is evident also in the corresponding AM/AM and AM/PM curves, in the form of a hysteresis loop (Fig. 3-4). The presence of hysteresis loops in the PA AM/AM and AM/PM curves is reported in [6] and MEs can be quantified calculating the loop opening in both Fig. 3 and Fig. 4:

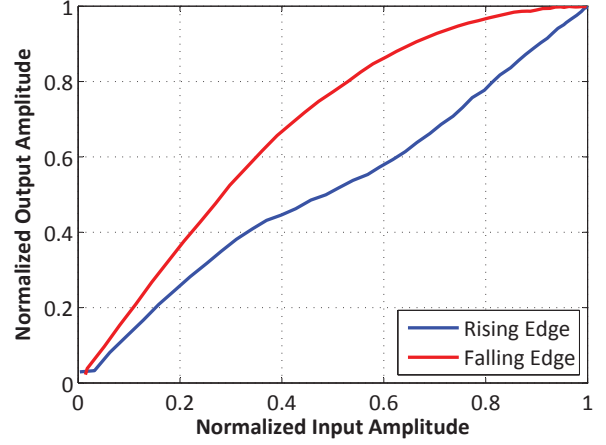

Fig. 3. Measured AM/AM characteristic. The blue trace is obtained from the rising edge and the red trace from the falling edge of PA input and output envelopes. The input signal is a two-tone signal with tone spacing of 1 MHz.

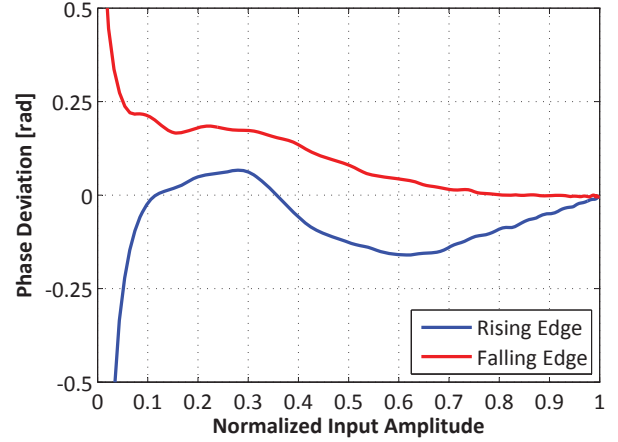

Fig. 4. Measured AM/PM characteristic. The blue trace is obtained from the rising edge and the red trace from the falling edge of PA input and output envelopes. The input signal is a two-tone signal with tone spacing of 1 MHz.

$$AM_{\text{opening}} = |y_{\text{fall}}(r)| - |y_{\text{rise}}(r)| \quad (5)$$

$$PM_{\text{opening}} = [\angle y_{\text{fall}}(r) - \angle x_{\text{fall}}(r)] - [\angle y_{\text{rise}}(r) - \angle x_{\text{rise}}(r)] \quad (6)$$

where r is the input amplitude, y_{rise} and y_{fall} are the rising and falling edge of the complex envelope of the PA response, x_{rise} and x_{fall} are the rising and falling edge of the complex envelope of the two-tone input signal, AM_{opening} is the amplitude loop opening in the AM/AM curve and PM_{opening} is the phase loop opening in the AM/PM curve.

Applying Eq. 5-6 to the AM/AM and AM/PM curves obtained for every two-tone measurement, the MEs can be plotted versus both the input signal amplitude and the two-tone frequency spacing. This dependency is shown in Fig. 5 when obtained from the AM/AM curves, and in Fig. 6 when obtained

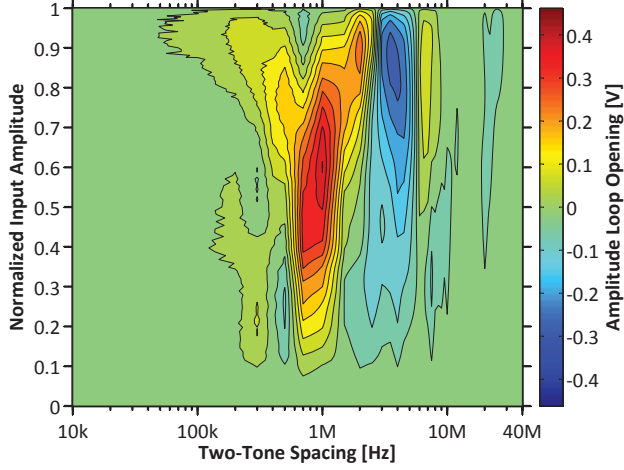

Fig. 5. Contour plot of the measured amplitude loop opening versus the input signal amplitude and the two-tone frequency spacing.

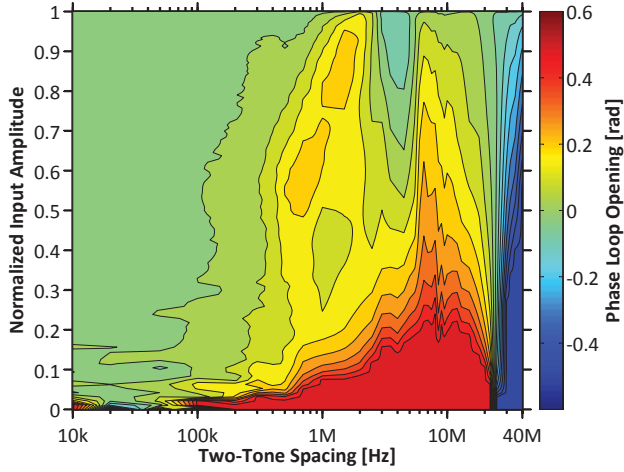

Fig. 6. Contour plot of the measured phase loop opening versus the input signal amplitude and the two-tone frequency spacing.

from the AM/PM curves. Fig. 5-6 are obtained interpolating the I and Q of each two-tone measurements in order to have the same number of points in the loop opening calculation. The values of the measured tone spacings are 10, 20, 50, 100, 200, 300, 400, 500, 700 kHz, and 1, 1.5, 2, 2.5, 3, 3.5, 4, 4.5, 5, 5.5, 6, 6.5, 7, 7.5, 8, 8.5, 9, 9.5, 10, 11, 12, 13, 15, 18, 20, 22, 25, 27, 30, 32, 35, 40 MHz. An interpolation between the measured tone spacings was also performed. The bottom part of Fig. 6 is not meaningful because of the large variations of the phase at amplitudes near to zero and to solve this issue the following estimators are proposed:

$$EVI = \text{Re} \left\{ \frac{EV \cdot AV^*}{|AV|} \right\} \quad (7)$$

$$EVQ = \text{Im} \left\{ \frac{EV \cdot AV^*}{|AV|} \right\} \quad (8)$$

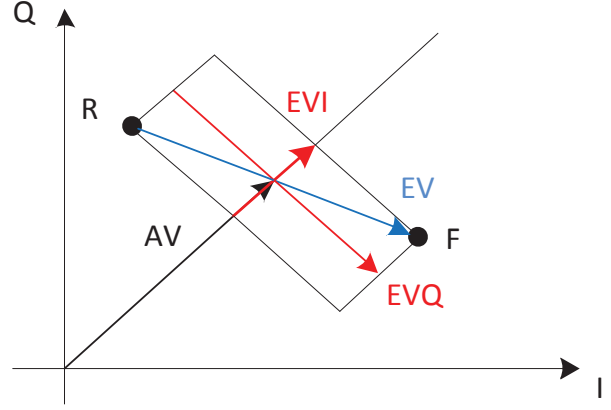

Fig. 7. Difference between two points of the rising edge (point R) and the falling edge (point F) of PA output. The difference vector EV is decomposed in its two components along AV and perpendicular to AV , where AV is the mean of vectors R and F .

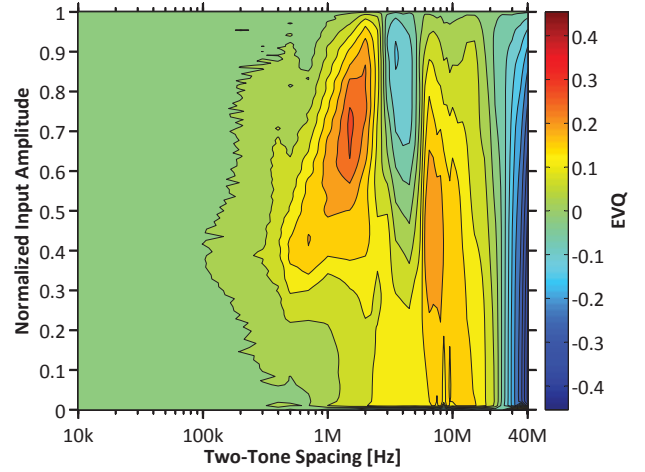

Fig. 8. Contour plot of the measured EVQ versus the input signal amplitude and the two-tone frequency spacing.

where EV is the difference between a pair of complex points (R and F) of the rising and falling edge of PA output taken at the same value of the input envelope amplitude $r(t)$, AV is the average between R and F and EVI and EVQ are the EV components parallel and perpendicular to the direction represented by the complex number AV when depicted as a vector in the I-Q plane (Fig. 7). The contour plot obtained when estimating the phase loop opening using the EVQ estimator is shown in Fig. 8 and it avoids the phase jumps corresponding to low amplitudes. The estimate performed using EVI produces a contour plot very similar to Fig. 5.

III. WIDEBAND LIMIT STUDY

From the ME mapping shown in Fig. 5 it is clear that the DUT shows predominant MEs in the frequency range from 400 kHz to 10 MHz. The application of the described ME mapping methodology allows to identify the wideband limit (WBL) of the DUT. It can be seen that the amount of memory

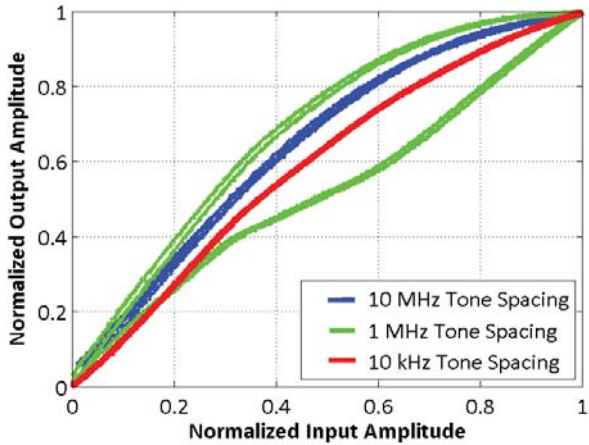

Fig. 9. Comparison of the AM/AM curves measured when applying a two-tone input signal with 10 kHz (quasi CW curve), 1 MHz (hysteresis loop) and 10 MHz (WBL) tone spacing.

effects is approximately zero for all tone spacings above 10 MHz and this represents the WBL of the measured DUT. The WBL can also be defined as the value of tone spacing beyond which the AM/AM curve collapses into a quasi-static curve. In [7] the authors have alluded to this phenomenon. The WBL is depicted in Fig. 9 by means of the comparison of the measured AM/AM curves for three different tone spacings. The static curve corresponds to a tone spacing of 10 kHz. By increasing the tone spacing, a hysteresis loop appears with different openings corresponding to different tone spacings. The wideband limit is observed at a tone spacing of 10 MHz, beyond which the AM/AM curve appears to be static again, with no presence of MEs. The quasi-static curve is different from the static one and it is caused by the fact that PA dynamic nonlinearities are not able to track the input two-tone signal. In the AM/PM curves the opening of the phase loop is not collapsing and an opening can be observed beyond the WBL (Fig. 10). It has been observed that in the AM/PM, the large opening at low input amplitudes is caused by a delay between the zero-crossings in the real and imaginary part of the PA response. The wideband limit can also be interpreted as a system feature. If a time constant is associated to each dynamic nonlinearity of the PA, the collapse of the AM/AM beyond the WBL is caused by the fact that the dynamic nonlinearities are not able to follow an input bandwidth larger than all the inverse of the time constants.

IV. CONCLUSION

In this paper the wideband limit of a GaN power amplifier is studied using two-tone measurements. The performed two-tone characterization procedure allows to estimate the magnitude and frequency range of PA dynamic nonlinearities. The upper limit of the ME frequency range represents the wideband limit (WBL) of the PA and it has been identified for the measured DUT. For all tone spacings beyond the WBL the AM/AM curve appears to be static again but this quasi-

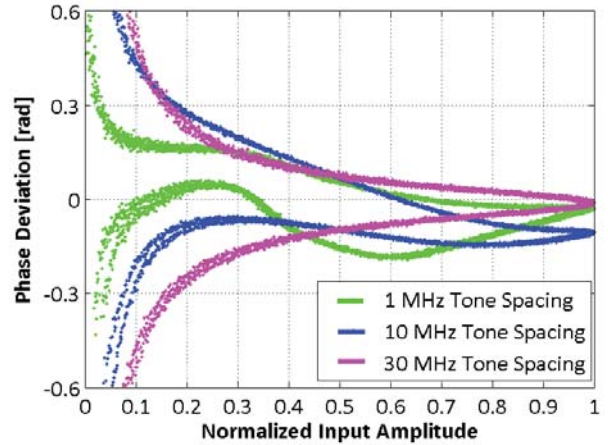

Fig. 10. Comparison of the AM/PM curves measured when applying a two-tone input signal with 1 MHz, 10 MHz (WBL) and 30 MHz (beyond WBL) tone spacing.

static case is different from the CW curve. From the AM/PM curves this collapse is not detected, but it has been observed that these curves are affected by measurement inaccuracies. The wideband limit is identified in this work for a device under test (DUT) that comprehends a GaN PA with two bias tees at input and output ports. Therefore, the mechanisms that cause the WBL to appear can be searched in both the PA dynamic nonlinearities (caused by trapping effects, self-heating, etc.) and also in the frequency response of the bias tees. The wideband limit is an important property of the DUT and its observation can be used to identify a behavioral model able to reproduce narrowly the range of the DUT memory effects.

ACKNOWLEDGEMENT

This work was supported by the Danish National Advanced Technology Foundation through the 4GMCT project.

REFERENCES

- [1] S. Cripps, *RF Power Amplifiers for Wireless Communication*. Artech House, 2006.
- [2] J. Vuolevi and T. Rahkonen, *Distortion in RF power amplifiers*. Artech House, 2003.
- [3] D. H. Wisell, B. Rudlund, and D. Ronnow, "Characterization of Memory Effects in Power Amplifiers Using Digital Two-Tone Measurements," *IEEE Transactions on Instrumentation and Measurement*, vol. 56, no. 6, pp. 2757–2766, Dec. 2007.
- [4] K. Remley, D. Williams, D.-P. Schreurs, and J. Wood, "Simplifying and Interpreting Two-Tone Measurements," *IEEE Transactions on Microwave Theory and Techniques*, vol. 52, no. 11, pp. 2576–2584, Nov. 2004.
- [5] N. Wolf, J.-E. Mueller, and H. Klar, "Identification of frequency dependent memory effects and the linearization of a CMOS PA for multiple standards," in *2009 IEEE Radio and Wireless Symposium*, Jan. 2009, pp. 598–601.
- [6] J. P. Martins, P. M. Cabral, N. Borges Carvalho, and J. C. Pedro, "A Metric for the Quantification of Memory Effects in Power Amplifiers," *IEEE Transactions on Microwave Theory and Techniques*, vol. 54, no. 12, pp. 4432–4439, Dec. 2006.
- [7] J. Verspecht, J. Horn, T. Nielsen, and D. E. Root, "Extension of X-parameters to Include Long-Term Dynamic Memory Effects," in *76th ARFTG Conference, IEEE Int. Microwave Symp. Dig.*, Clearwater beach, Florida, USA, 2010, pp. 1–45.