



UvA-DARE (Digital Academic Repository)

ARTICONF decentralized social media platform for democratic crowd journalism

Rito Lima, I.; Filipe, V.; Marinho, C.; Ulisses, A.; Chakravorty, A.; Hristov, A.; Saurabh, N.; Zhao, Z.; Xin, R.; Prodan, R.

DOI

[10.1007/s13278-023-01110-y](https://doi.org/10.1007/s13278-023-01110-y)

Publication date

2023

Document Version

Final published version

Published in

Social Network Analysis and Mining

License

CC BY

[Link to publication](#)

Citation for published version (APA):

Rito Lima, I., Filipe, V., Marinho, C., Ulisses, A., Chakravorty, A., Hristov, A., Saurabh, N., Zhao, Z., Xin, R., & Prodan, R. (2023). ARTICONF decentralized social media platform for democratic crowd journalism. *Social Network Analysis and Mining*, 13, Article 116. <https://doi.org/10.1007/s13278-023-01110-y>

General rights

It is not permitted to download or to forward/distribute the text or part of it without the consent of the author(s) and/or copyright holder(s), other than for strictly personal, individual use, unless the work is under an open content license (like Creative Commons).

Disclaimer/Complaints regulations

If you believe that digital publication of certain material infringes any of your rights or (privacy) interests, please let the Library know, stating your reasons. In case of a legitimate complaint, the Library will make the material inaccessible and/or remove it from the website. Please Ask the Library: <https://uba.uva.nl/en/contact>, or a letter to: Library of the University of Amsterdam, Secretariat, Singel 425, 1012 WP Amsterdam, The Netherlands. You will be contacted as soon as possible.



ARTICONF decentralized social media platform for democratic crowd journalism

Inês Rito Lima¹ · Vasco Filipe¹ · Claudia Marinho¹ · Alexandre Ulisses¹ · Antorweep Chakravorty² · Atanas Hristov³ · Nishant Saurabh⁴ · Zhiming Zhao⁵ · Ruyue Xin⁵ · Radu Prodan⁶

Received: 15 March 2023 / Revised: 27 July 2023 / Accepted: 28 July 2023 / Published online: 15 September 2023
© The Author(s) 2023

Abstract

Media production and consumption behaviors are changing in response to new technologies and demands, giving birth to a new generation of social applications. Among them, crowd journalism represents a novel way of constructing democratic and trustworthy news relying on ordinary citizens arriving at breaking news locations and capturing relevant videos using their smartphones. The ARTICONF project as reported by Prodan (Euro-Par 2019: parallel processing workshops, Springer, 2019) proposes a trustworthy, resilient, and globally sustainable toolset for developing decentralized applications (DApps) to address this need. Its goal is to overcome the privacy, trust, and autonomy-related concerns associated with proprietary social media platforms overflowed by fake news. Leveraging the ARTICONF tools, we introduce a new DApp for crowd journalism called MOGPlay. MOGPlay collects and manages audiovisual content generated by citizens and provides a secure blockchain platform that rewards all stakeholders involved in professional news production. Besides live streaming, MOGPlay offers a marketplace for audiovisual content trading among citizens and free journalists with an internal token ecosystem. We discuss the functionality and implementation of the MOGPlay DApp and illustrate four pilot crowd journalism live scenarios that validate the prototype.

Keywords Crowd journalism · Citizen-generated content · Decentralized app · Social media · Marketplace

✉ Radu Prodan
radu.prodan@aau.at

Inês Rito Lima
ines.lima@mog-technologies.com

Vasco Filipe
vasco.filipe@mog-technologies.com

Claudia Marinho
claudia.marinho@mog-technologies.com

Alexandre Ulisses
alexandre.ulisses@mog-technologies.com

Antorweep Chakravorty
antorweep.chakravorty@uis.no

Atanas Hristov
atanas.hristov@uist.edu.mk

Nishant Saurabh
n.saurabh@uu.nl

Zhiming Zhao
z.zhao@uva.nl

Ruyue Xin
r.xin@uva.nl

¹ Department of Innovation, MOG Technologies, R. Eng. Frederico Ulrich 265, 4470-605 Maia, Portugal

² Faculty of Science and Technology, University of Stavanger, Kristine Bonnevis vei 22, 4021 Stavanger, Norway

³ Faculty of Information Theory and Analysis, University for Information Science and Technology, Partizanska bb, 6000 Ohrid, North Macedonia

⁴ Department of Information and Computing Sciences, Utrecht University, Princetonplein 5, 3584 CC Utrecht, Netherlands

⁵ Multiscale Networked Systems, University of Amsterdam, Science Park 904, 1090 GH Amsterdam, Netherlands

⁶ Department of Information Technology, University of Klagenfurt, Universitätsstraße 65-67, 9020 Klagenfurt, Austria

1 Introduction

The last decade saw an exponential increase in people's online engagement regardless of age, gender, or nationality through popular social media platforms, eventually creating a "Social Continuum". Unfortunately, popular social networks such as Facebook, Twitter, LinkedIn, WeChat, or TikTok are monolithic platforms hosted on centralized Cloud data centers and controlled by a single company. Central ownership raises trust issues and increases concern for data security, privacy, transparency, and false content propagation. Typical examples are fake identities engaging in controversial discussions or deliberately communicating low-quality manipulative information that spreads quicker and attracts more audiences than credible sources. Consequently, the news media get increasingly polarized between different societal fractions generating conflicts of interest and biased debates that deviate from the authentic topic. Social networks spreading fake news worsen this fragmentation. Citizens lack trustworthy and objective sources of information to form an educated, unbiased opinion that does not raise political or societal conflicts of interest.

Crowd journalism The significant evolution of mobile devices with high video and audio capturing features has enabled the rise of the term *crowd journalism*, also referred to as citizen or crowdsourced journalism (Hunter 2021; Engelke 2019). This concept surfaced back in 2004 after the Indian Ocean tsunami and has gained prominence in discussions about journalism's current state and future as a collaborative model. Nowadays, it is common for ordinary citizens to arrive at breaking news locations and capture relevant videos of the incident using their smartphones. Moreover, there is often a significant delay between the content captured by the first citizen to arrive at the incident location and the professional journalists. In cases of breaking news with critical timings, such as explosions, informing the citizens as soon as possible is essential, even if the broadcast is of lower quality than waiting for professionals. Several citizen journalism websites foster active citizen-generated content production and collection¹ aiming to close the gap between participatory journalism and content published on social media. Despite the increasing ease of generating content and participating in news production, crowd journalism also entails risks since dark participation can deliberately produce misinformation and offensive content (Panagiotidis et al. 2020; Engelke 2019). Online newspaper participatory journalism (Spyridou 2019) highlights that contributions requiring prior registration have higher content quality than anonymous involvement. Nevertheless, balancing the control

shared between professional journalists and participatory audiences is paramount and a less covered topic (Borger et al. 2019).

Social DApps To mitigate such challenges, *Decentralized Social Applications (Social DApps)*, based on blockchain technology and hosted on a federated Cloud, promise to create a secure and practically inviolable Social Continuum, connecting billions of people under no centralized control and allowing them to share information using democratic consensus protocols safely. The *ARTICONF project* (Prodan et al. 2019) researches and develops a *Blockchain-as-a-Service (BaaS)* platform for building trustworthy, scalable, and democratic Social DApps on a decentralized, federated Cloud infrastructure by:

1. Streamlining the creation of agile DApps using a two-stage permissioned blockchain architecture;
2. Automatically detecting and analyzing contextualized interest groups and communities without privacy violation;
3. Elastically auto-scaling social media DApps on adaptive Cloud infrastructures according to their requirements;
4. Amplifying monetary inclusion in collaborative models through smart aggregation and guided analytics.

By creating an open, transparent, and agile ecosystem supported by underlying blockchain technology, ARTICONF presents itself as an alternative to centralized social media platforms controlled by single authorities.

MOGPlay This article presents a case study of applying the ARTICONF tools for implementing, operating, and validating a novel crowd journalism DApp called *MOGPlay* that allows regular citizens to capture live videos during an event and stream them in real time to a decentralized, federated Cloud platform. ARTICONF allows fast ad hoc Cloud deployment of a Social DApp by regular citizens near an unexpected or isolated event, allowing its coverage before professional journalists and media companies arrive. News reporters can use the DApp to create comprehensive joint event footage that accommodates diverse angles and perspectives, with integrated fake news identification and filtering. ARTICONF BaaS platform ensures the privacy and anonymity of citizens and journalists and prohibits censorship or fake news propagation. We tested and validated the MOGPlay DApp at the Jungfrau Marathon 2021 in Switzerland, one of the most demanding marathons in the world, gathering and engaging hundreds of journalists and users. Around 200 participants streamed the event from their mobile phones to the ARTICONF BaaS platform generating over six hours of coverage and over 500 views on a designated YouTube channel. Other events covered by the MOGPlay crowd journalism DApp are the Jornal de Notícias

¹ https://www.sourcewatch.org/index.php/List_of_citizen_journalism_websites.

book fair, the Extinction Rebellion's environment event, and the Jump Around hip-hop music festival in Porto.

Outline Sect. 2 summarizes the state-of-the-art in decentralized social media and existing crowd journalism. Section 3 introduces the ARTICONF toolset for DApp development. Section 4 describes the crowd journalism stakeholders and its integration with ARTICONF tools. Section 5 presents the architecture, implementation, and graphical interface of the MOGPlay DApp for crowd journalism. Section 6 explains the support of the integrated ARTICONF tools for crowd journalism. Section 7 describes the validation of the MOGPlay prototype for covering four public events with different profiles (cultural, sportive, and musical). Section 8 concludes the article.

2 Related work

We review in this work the related work in the two complementary areas unified in this article: decentralized social media in Sect. 2.1 and crowd journalism in Sect. 2.2.

2.1 Decentralized social media

Diaspora Bielenberg et al. (2012) is a non-profit, user-owned, distributed social network that addresses privacy concerns related to centralized networks. It consists of a network of nodes called pods hosted by different individuals and institutions. Each node operates a copy of the Diaspora software as a personal web server with social networking capabilities. Network users can host a pod on their server or create an account on any pod to interact with other users. The users retain data ownership and do not assign ownership rights.

Steem² Destabelle (2019) is a social blockchain (Guidi et al. 2020, 2021) that grows communities and generates revenue streams by rewarding users for sharing content. It supports community building and social interaction with cryptocurrency rewards. Steem supports social media and online communities by returning its value to those who provide valuable contributions (e.g., content generation and propagation) and rewarding them with cryptocurrency. This process creates a currency able to reach a broad market, including people who have yet to participate in any cryptocurrency-sharing economy.

UHIVE³ is a blockchain-based, privacy-aware social media with token rewards for content producers and consumers, which respects privacy by not logging user activities and by permanently deleting data. The network distributes

revenues and rewards in exchange for content, engagement with posts, and time spent on the app. It also provides a content discovery UX powered by interest-based user selection. Finally, it supports public, personal, and interest-based user profiles.

Minds⁴ is a decentralized social networking platform that rewards users with tokens for contributions to the community. Minds provides a free, open-source, distributed crypto-social networking service that uses blockchain to reward the community with ERC-20 tokens. Minds users can use their tokens to promote content or to crowdfund other users through monthly subscriptions to exclusive content and services.

Matic⁵ is a decentralized network that scales through sidechains for off-chain computation and uses the plasma framework and proof-of-stake validators for security. It provides scalability and superior user experience to DApps by using sidechains to guarantee fast, low-cost, secure transactions. Matic uses Ethereum but intends to offer support for additional base chains. Additionally, it provides a developer abstraction from the main chain to a Matic chain, native mobile apps, and wallet support. Moreover, Matic uses public, permissionless sidechains capable of supporting multiple protocols.

Sapien⁶ is a social news platform that offers users control over their data. Sapien utilizes a unique engine for rewarding content creators with SPN tokens by accepting micro-payments or subscriptions and allowing users to get SPN from advertisers. Additionally, it constructs a global reputation system that uses smart contracts to evaluate individual contributions.

AKASHA (Xu et al. 2018) (Advanced Knowledge Architecture for Social Human Advocacy) is a decentralized, alternative social media network resistant to Internet censorship, deployed using Ethereum blockchain and the Inter-Planetary File System (IPFS) (Benet 2014). AKASHA provides a modern content publishing platform across a decentralized network rather than proprietary servers. This enables users to share information independent of any centralized entity, primarily due to IPFS network use and P2P communication. Users can share and vote for the published content, bundled with microtransactions for each content to generate value based on quality.

MASTODON (Liu et al. 2020) is a free and open-source self-hosted social network that provides tools for community-based moderation (Zignani et al. 2018; Rossaro and Surquin 2019), where each hosting server can limit or filter undesirable types of content (Raman et al. 2019; Zignani

² <https://steem.com/>.

³ <https://www.uhive.com/>.

⁴ <https://www.minds.com/>.

⁵ <https://matic.network/>.

⁶ <https://www.sapien.network/>.

et al. 2019). MASTODON also provides an interface for finding appropriate communities.

2.2 Crowd journalism

Crowd or participatory journalism refers to professional news production with active audience participation (Engelke 2019; Hunter 2021; Antonopoulos et al. 2020) and inclusion of citizen-generated content in professional journalism. This form of content intends to supplement the professional news production processes and differs from the autonomous content published on social media (Engelke 2019). Media organizations are embracing participatory journalism to overcome the crisis of traditional journalism falling into a cycle of lower audiences, revenue, content quality, and credibility (Palomo et al. 2019; Antonopoulos et al. 2020). Other forms of audience involvement in journalism include crowdsourcing and crowdfunding, where citizens share ideas, sources, or expertise with journalists and financially support journalistic projects (Hunter 2021). Both strategies help shift the traditional news production mindset and business model (Hunter 2021; Antonopoulos et al. 2020).

An extensive literature overview on crowd journalism (Engelke 2019) divides citizen participation into formation, dissemination, and interpretation. Within formation, journalists' increasing use of citizen-generated content supplements their news production process. The advantage of crowd journalism is its potential to attract new users, foster transparency and credibility in the news generated, build trust regarding its content, and increase web traffic (Palomo et al. 2019). Its conditions and requirements include decentralization, collaboration, and (non-proprietary) democratization (Antonopoulos et al. 2020), attracting more citizens to contribute to news production actively. Crowd journalism enables the publication and dissemination of news that otherwise would not reach the public (Palomo et al. 2019) and potentially impacts all information areas.

Registration rules imposing named (as opposed to anonymous) participation tend to positively influence content creation (Diakopoulos and Naaman 2011) and upper quality of debates in online newspapers (Spyridou 2019)

Recent research addresses the open issue of managing crowd journalism content. Five isolated projects on active collaboration between professional journalists and audiences (Borger et al. 2019) evaluate the different management models, participation roles, and control shared over the news produced. Additionally, (Palomo et al. 2019) debates the need for formalized collaborative platforms to securely leverage citizen content into professional news production. The SEMPRATO open-source semantic platform (Panagiotidis et al. 2020; Saridou et al. 2019) manages a flexible collection of textual participatory citizen content but lacks content

prioritization according to journalists' needs (Panagiotidis et al. 2020).

The state-of-the-art highlights the need for collecting and managing high-quality citizen content that meets journalism standards. A decentralized platform increases trust and reliability from citizens' perspectives and motivates participation. Crowd journalism on audiovisual content for media production is a less covered topic and the focus of this article.

3 ARTICONF toolset for social DApps

ARTICONF researches and develops BaaS consisting of four open-source tools that support the development of trustworthy, secure, and scalable Social DApps. Although several platforms (e.g., Steem, AKasha) address similar goals, ARTICONF is the first European open-source initiative to build its solution on a Cloud-agnostic BaaS federated infrastructure. The ARTICONF project aims to create an ecosystem supported by four tools for social DApp development, with crowd journalism as one of its representative use cases.

3.1 Trust and integration controller (TIC)

DApp deployment requires a diverse computing infrastructure and many frameworks, solutions, and standards integrated cohesively to facilitate acceptable performance and security. State-of-the-art still lacks the necessary tools to provision the required infrastructure and ensure its continued maintenance while at the same time ensuring adherence to privacy, security, and trust policies. Furthermore, the inherent complexities of the underlying infrastructure need to be encapsulated in a manner that allows DApp developers to prioritize their applications rather than the infrastructure itself. TIC's cloud-agnostic toolkit allows blockchain-based deployments for creating social media DApps with increased participant outreach. With other tools, TIC enables customers, consumers, prosumers, and businesses to participate in a trustful, secure, and transparent environment while providing monetization opportunities.

Architectural microservices TIC provides several microservices to offer this functionality.

Blockchain consortium It is the core service that integrates several third-party authentication providers to verify and provide a unique identity to users joining the network. TIC automatically deploys a blockchain to any Cloud infrastructure by specifying the required architecture and connection details through a configuration file.

Relationship system It offers a library to create and manage Turing-complete smart contracts that handle logical processing and allow users to set data sharing and rights with

complete content control. DApp developers can extend it according to their specific privacy and security requirements.

Certificate authority It is a client software development kit for issuing user certificates, encrypting sensitive data before broadcasting, and persisting it on the blockchain and the Cloud data storage.

Cloud big data storage It allows distributed storage of large, shared data with efficient indexing and traversals that ensure the same version of the truth among all nodes. The storage also offers redundancy and encryption by maintaining a map for each encrypted content transacted on the blockchain with their respective hash identifiers.

Software development kit It offers drivers for developers to integrate their DApps developed for different platforms with the blockchain network. It facilitates initiating new transactions by reviewing the existing ones and calling the smart contracts.

3.2 Co-located and orchestrated network fabric (CONF)

CONF supports elastic provisioning of virtual infrastructures for social media DApps over an orchestrated network. It seamlessly integrates with Cloud infrastructures to intelligently provision services based on the DApp requirements. CONF can stream and automate the runtime DApp deployment, monitoring, and adaptation.

Architectural microservices CONF provides four microservices to offer this functionality.

Infrastructure planer It uses a critical path algorithm optimized for handling time-critical constraints in decentralized applications. Its main goal is to create efficient infrastructure topologies for the application, selecting the most cost-effective virtual machines (VM).

Provisioning agent It automates the provisioning of the infrastructure plans onto the underlying services. The provisioning agent interprets and deploys the infrastructure configuration with transparent network configuration across multiple Cloud infrastructures.

Deployment agent It is responsible for installing the DApp and a monitoring system that autonomously collects runtime execution metrics on the underlying infrastructure.

Controller agent It controls and adjusts the cloud infrastructure at runtime in response to the quality of service metrics of the deployed application and its underlying infrastructure to ensure system self-adaptability.

3.3 Semantic model with self-adaptive autonomous relevant technology (SMART)

SMART data-driven tool finds relevant interest groups without violating users' privacy and anonymity. Moreover, SMART provides democratic and tokenized

decision-making and reputation mechanisms to solve disputes in collaborative models, preserving the trustful and autonomous users-centric environment.

Architectural microservices SMART provides five microservices to offer this functionality.

Semantic framework for federated social media It is a conceptualization model that exploits decentralized reasoning and relevant communities with interest groups, involving large-scale entities with three levels of abstraction: concrete perception of users and of associated smart objects in a global domain, structure of the perceived relationships, and communication among entities

Autonomous and adaptive user-centric model It consists of role-stage programming model techniques that integrate various facets of social media to design and implement a flexible, adaptive, user-centric ecosystem. This microservice also implements a human-agent collective-based model describing, reasoning, and conceptualizing consumer, prosumer, and business processes at model description and runtime.

Anonymized trace abstraction It uses the experiential anonymized activities embedded in blockchain as traces that take advantage of trace comparison and retrieval, providing effective and quick adaptation.

Anonymized trace abstraction It uses the experiential anonymized activities embedded in blockchain as traces that take advantage of trace comparison and retrieval, providing effective and quick adaptation. Smart matching with community detection consists of predictive techniques for social media businesses to engage with relevant audiences and communities based on semantic abstraction and application requirements.

Decentralized decision-making and reputation It provides opportunities to all entities, irrespective of their roles, to improve the efficiency of collaborative business and prosumer models. Therefore, it eliminates disputes and dissatisfaction between entities via decentralized participation while providing incentivization opportunities.

3.4 Tools for analytics and cognition (TAC)

TAC is a tool for analytics and cognition (Karadimce et al. 2020) that injects additional information to improve operational tasks, planning, and managing social media DApp providers. TAC handles geospatial and temporal data pre-processing, visualizes them in a guided analytics dashboard, and introduces intelligent business revenue predictions with the help of the SMART tool.

Architectural microservices TAC provides several microservices to deliver this functionality.

Geospatial It gathers, displays, and manipulates the data consisting of longitude and latitude information, meaningful

to prosumers for boosting their experience and economic benefits.

Temporal It supports complex analyses of the ARTI-CONF social network and allows users to benefit from actionable insights from a large amount of data processed over a short period.

Return on investment (ROI) It runs the testing, measurement, and evaluation of the DApp's key performance indicators and calculates the ecosystem's overall success metric. This measurement supports the customizations according to the needs of the social media providers.

Return on collaboration (ROC) It provides quantified values representing revenues relative to each functional area's capital invested. Measuring ROC determines the impact of integrating social media services by real-time tracking of engagements' true reach and ROI. It enables providers to receive real-time cost-per-engagement analyses and define their use case's success indicators.

Visualization It guides social network providers by analyzing and visualizing the parameters of interest with specific configurations for each DApp. Thus, the analysis moves beyond reporting shallow summary data to provide solid and actionable consumer insights. The goal is to aid in-depth studies of social media data. The validation of the visualization diagrams takes place in three steps: (1) *TAC developers* provide visualizations using carefully simulated sample datasets, (2) *Providers* deliver real datasets, undergoing specific processing and manipulations for obtaining the same visualization insights, and (3) *TAC testers* compare sets' output to validate data flows, applications, and visualization changes.

Guided analytics It provides social media providers with dashboards for different DApps that display aggregated summary information and visualizations of their objective metrics.

3.5 Implementation

ARTICONF uses the following Cloud technologies as part of its BaaS toolset for Social DApp development and operation:

- *Hyperledger fabric* (open source) for blockchain implementations;
- *OpenStack* (open source), *Amazon Web Services*, and *Google Cloud* for federated BaaS deployment;
- *Gluster file system* (open source) for distributed, scalable, resilient, and concurrent blockchain data storage for Social DApps;
- *Kubernetes* for reliable and scalable Cloud-native BaaS orchestration;
- *Topology and orchestration specification for cloud applications (TOSCA)* for describing and mapping the Cloud

infrastructure topology with performance requirements of Social DApps;

- *Elasticsearch* and *Kibana* (open-source) for blockchain transaction analysis and visualization;
- *Docker CE* (open-source) for the tools packaging and delivery;
- *SonarQube* (open-source) for measuring and analyzing code quality;
- *Jenkins* (open-source) based on continuous development, integration, and delivery of the toolset microservices.

4 Crowd journalism

Crowd journalism allows independent journalists and the news broadcasting industry to create content outside the mainstream media by gathering crowdsourced news from public participation. It enhances the video and audio capture experiences for collaborative news content creation. Additionally, multi-user live streaming functionality optimizes cooperation among citizens (i.e., crowd entities) and professional journalists to produce news content with increased benefit and democratic credibility.

4.1 Stakeholders

Users can assume three crowd journalism roles: citizen, news reporter, or news platform manager. Most functionalities are available to all stakeholders, but some have restrictions or special permissions. All stakeholders can contribute anonymously to the coverage of breaking news events or use a personal account.

Citizens They have standard permissions and produce community content using their free time and personal resources or as video consumers to visualize contributions from other users (live or on-demand). Citizens can receive textual feedback from the editing room while capturing a live event, which motivates them to continue streaming. There are two types of citizens.

Workers They use their smartphones to access the MOG-Play DApp to capture high-quality video or audio of a breaking news event.

Video consumers They use the DApp to watch multiple simultaneous live videos showing different perspectives of the event from different workers. In this process, consumers classify and rate the videos in real time, considering various parameters, such as their perceived impact on the video. Consumers can also access a *News Video Marketplace* to browse, search, filter, sort (e.g., by rating, duration), and preview contributions from other users (in a video-on-demand (VOD) format), and download their videos. Consumers can also trade videos with other users and receive rewards for covering an event.

News reporters News reporters are professional journalists who, like citizens, can act as workers to produce live video contributions or as consumers to browse them. News reporters have three privileges over citizens.

Enhanced access While citizens can freely register and access their accounts, only news platform managers can create news reporter accounts with enhanced access rights.

Audio feedback News reporters can receive audio and textual feedback while creating live feeds.

News video editor News reporters can provide professional video switching of live streams created on the platform. This interface allows them to analyze, browse, filter, and select the most relevant streams relayed to external broadcast channels such as YouTube Live.

News platform managers They are professional journalists with more permission than news reporters. They access an administration dashboard to create events associated with their interest. Only citizens within this specific event area can contribute to the community during the event. News platform managers can invite new professional users to join the platform through the administration dashboard.

4.2 Design

To deploy a crowd journalism DApp in ARTICONF, a news platform manager must define and send a Topology and Orchestration Specification for Cloud Applications (TOSCA) file to CONF with the different microservices' configurations and their means of communication using a representational state transfer (RESTful) API (see Fig. 1). CONF parses the configuration file and deploys the requested containers in VM exclusively created for the DApp instance. The TOSCA file also describes the policies for managing the scaling microservices. CONF can scale the instance up or down at the container or VM level according to the guidelines defined by the news platform manager. TIC uses the deployment capabilities of CONF to run a blockchain network and its management tools to monitor the network and retrieve runtime information. SMART and TAC, simultaneously instantiated with the TIC deployment, jointly retrieve information from the blockchain (TIC), analyze (SMART), and present it (TAC). The news platform manager accesses a TAC dashboard containing relevant information about the use case. After deploying the use case, the user has four ways to interact with TIC.

Identity registration A stakeholder uses this identity to invoke or query the chaincode instantiated in the TIC blockchain network. An identity can have different permission policies depending on the stakeholder.

Capture module The Media Engine receives the stream incoming from the Capture Module and uses TIC to register the associated information in the blockchain. The

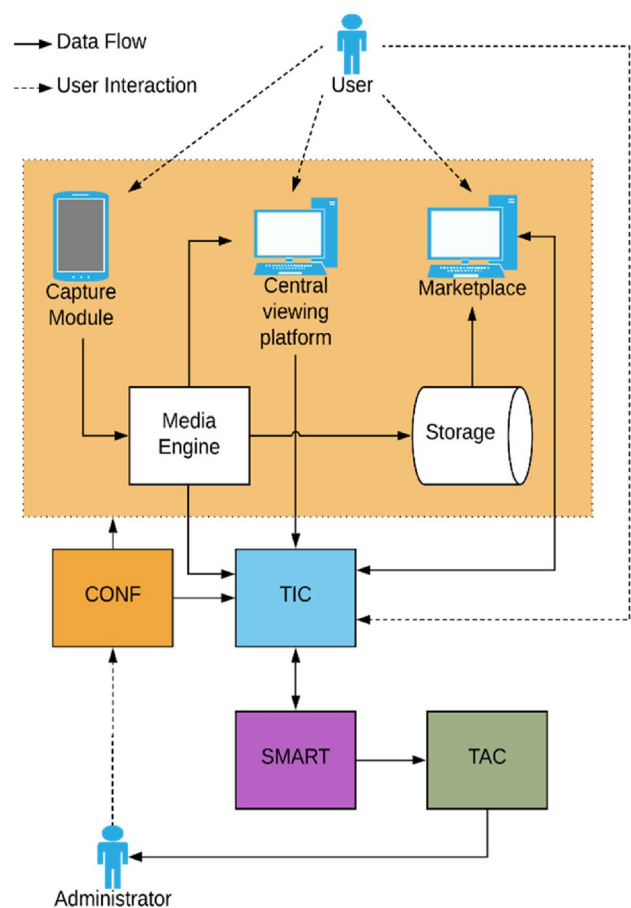

Fig. 1 Crowd journalism design in ARTICONF

stakeholder must provide the Capture Module with an identifier for purchase rewards.

Central viewing platform The blockchain network records each video with a unique worker identifier, used by consumers to query and associate ratings. Consumers can rate a video multiple times, but only the latest one is relevant.

News video marketplace By querying the blockchain, consumers can associate a video with its owner identifier. Consumers can purchase video on the blockchain marketplace by transferring a certain number of tokens to its owner and then accessing the video asset link.

4.3 News verification

Crowd journalism allows citizens and journalists to receive insights into the credibility of the news videos in the News Video Marketplace. The objective is not to provide a binary decision on the news authenticity but to associate a level of credibility to each news video, which helps potential buyers make an informed decision. This

Fig. 2 MOGPlay DApp architecture

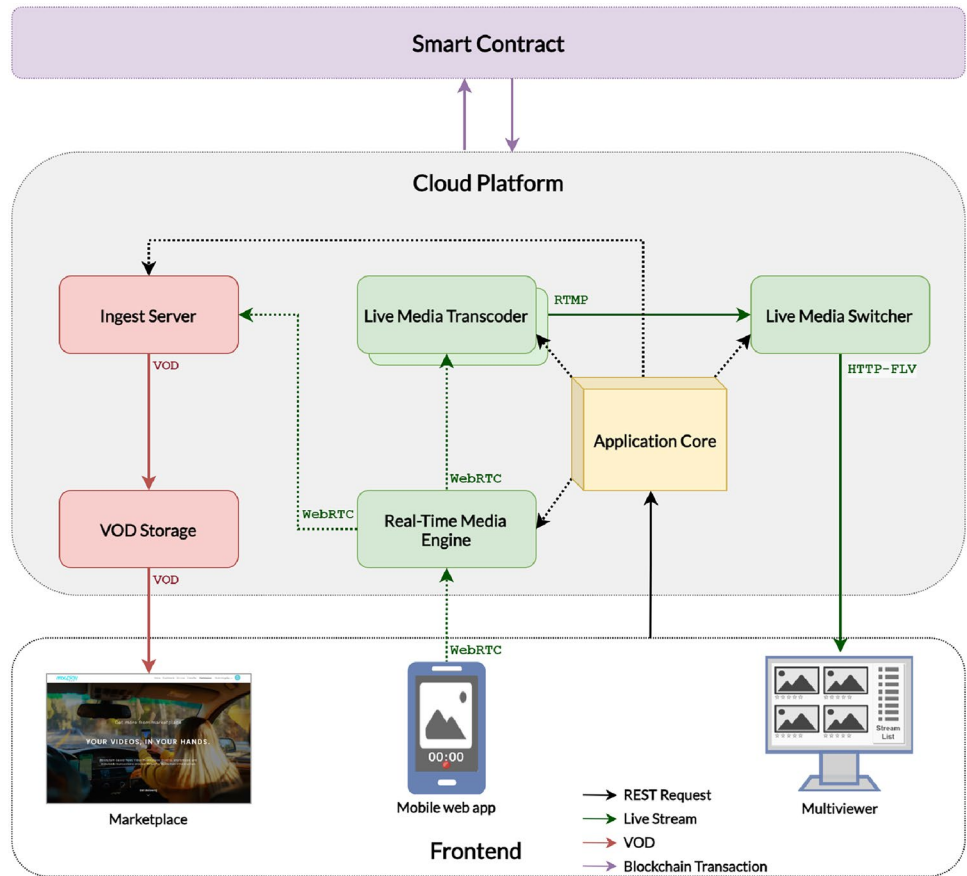

approach reduces misinformation and contributes to the fight against fake news dissemination. Crowd journalism uses three methods for news verification.

Geolocation of citizens and journalists The news platform manager assigns a specific geographical area to a crowd journalism event during the news video creation. Afterward, only citizens and journalists within this area can capture news videos with the mobile app. This constraint ensures that all videos stream from the event location and avoids malicious actors sharing fake videos from other areas.

Democratic live watching and rating During a crowd journalism event, citizens and journalists watch and classify the live news videos other citizens and journalists capture. The key in this democratic process is to gather information provided by citizens and journalists during this classification process and to use this data to assign a preliminary level of credibility to each news video. Citizens and journalists can rate three parametric levels of a news video: informativeness, impact, and trustiness. Such a democratic and participatory news ecosystem lets buyers know what the other crowd entities think about a particular video to better reflect on their transactions.

ML-based verification SMART helps increase credibility accuracy by employing ML-based classification techniques on the news available on the blockchain.

5 MOGPlay crowd journalism DApp

Figure 2 presents an overview of the MOGPlay crowd journalism architecture comprising three major components: Cloud Platform, Smart Contract, and MOGPlay Mobile App.

5.1 Cloud platform

The Cloud Platform is the backbone of the DApp, comprising seven back-end microservices responsible for media processing, serving live or VOD videos to the end-users, and processing their input, among others (see Fig. 2). The Cloud Platform runs in a Kubernetes cluster managed through Helm to ensure availability, reliability, and scalability. Kubernetes allows for a distributed deployment, possibly deploying new services or decommissioning them as needed. It also collects hardware, network, and application-level metrics to help load balancing, scaling, and fault recovery.

Real-time media engine This Web Real-Time Communication (WebRTC) server receives the live video and

Fig. 3 Application Core architecture

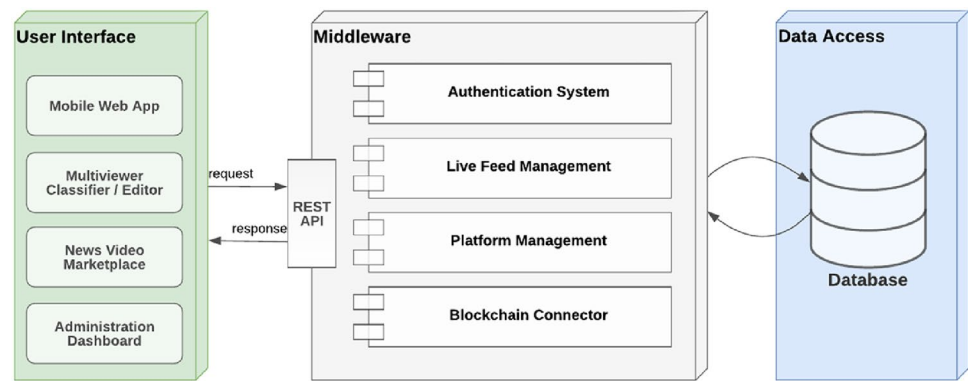

audio captured by the users and relays it to the Live Media Transcoder for further media processing. It further acts as a signaling broker for the WebRTC connections to establish media sessions between the web clients and exchange the necessary metadata to coordinate communication. The Real-Time Media Engine uses Session Traversal Utilities for NAT (STUN), and Traversal Using Relays around NAT (TURN) servers based on the Coturn open-source implementation to traverse firewalls and the network address translations in real-world scenarios. Coturn acts as a STUN server and uses a TURN server as a fallback if a direct peer-to-peer (P2P) connection fails. If the Web application fails to connect with the Real-Time Media Engine, the STUN server deployed using Coturn represents a fallback. If the STUN server also fails, routing the traffic via the TURN relay server (also deployed with Coturn) is the last resort.

Live media transcoder The variable framerates and resolutions supported by the WebRTC streaming protocol can lead to delivery compatibility problems. The Live Media Transcoder implemented by a Node.js server converts all streams to standardized specifications using the GStreamer command-line interface. It uses FFmpeg to publish the output feed to a Real-Time Messaging Protocol (RTMP) channel, such as YouTube Live.

Live media switcher This media server simultaneously receives RTMP streams from the Live Media Transcoder and chooses one as output, supplied to broadcast on channels like YouTube Live. It is also responsible for delivering live feeds to the Multiviewer Editor or Classifier. Since browsers do not support RTMP videos without plug-ins (e.g., Adobe Flash Player deprecated in 2020), the Live Media Switcher uses NGINX to provide four monitoring streams to the Multiviewer interface in the HTTP-FLV format.

Ingest server This media engine, implemented by a Node.js server, converts video streams from the VOD Storage to playable files using FFmpeg and Janus post-processing record tools. Furthermore, it communicates with the blockchain to provide additional video data, including the identifier, video and audio codecs, duration, paths to the

original video and watermark preview, creation timestamp, MD5 protection hash, the creator, and a thumbnail array.

VOD storage This media database implemented using NGINX stores all captured videos, either temporarily or permanently, with a unique associated fingerprint. Upon completing a transaction (e.g., News Video Marketplace purchase), the video is available for download, and the Smart Contract service rewards its producer using the corresponding fingerprint. The VOD Storage also implements access control to the videos of the News Video Marketplace. Downloading or visualizing original videos is possible upon supplying the authorization token, which identifies the intended recording and gives access for a limited time.

Resource manager This Express Web Server implemented using Node.js supports multiple user live feeds distributed among multiple Live Media Transcoder pods and keeps track of their availability. If no transcoder is available, it issues a pod creation request to the Kubernetes API Server. As the request is asynchronous, it waits for the complete initialization of the transcoder before relaying the new pod's IP address to the Application Core. The Resource Manager subscribes to pod deletions so that a newly created transcoder takes over in case of crashes.

Application Core This server, implemented using a Node.js JavaScript runtime environment outside a browser, communicates with other services via REST requests, ensuring the complete workflow (see Fig. 3) using four components.

Authentication system It allows the DApp to register new user identities in the blockchain. Each user adding transactions to the blockchain has a certificate to authenticate and validate the operation requests.

Live feed management It is responsible for handling the whole media workflow and communicating with other platform components to forward the content created on the application to the respective modules for further media processing. As such, this component ensures the live and VOD media workflow in the MOGPlay DApp.

Platform management It is responsible for processing the user's inputs and actions while storing and retrieving the data between the GUI and a local PostgreSQL database and between the GUI and the Smart Contract in response to the users' actions. This data includes mostly auxiliary information necessary for the GUI to function, such as the user credentials' details, login sessions, and shopping cart data.

Blockchain connector It facilitates communication with the blockchain network and invokes Smart Contract methods asked by the front end.

Microservices workflow The Application Core provides essential instructions to the different microservices of the Cloud Platform.

Resource Manager When a worker starts streaming, the Application Core queries the Resource Manager for Media Transcoder pods with resources available to transcode one live feed. Likewise, when one user stops streaming, the Application Core informs the Resource Manager to free the user's resources;

Real-time media engine When a worker creates a live stream, the Application Core provides the network information to relay it to the Real-Time Engine;

Live media transcoder When a citizen creates or stops a live feed, the Application Core informs the Live Media Transcoder and acts accordingly. Additionally, it reports to the Live Media Transcoder upon request to start or stop broadcasting the output feed to external channels;

Live media switcher Upon a selection in the Multiviewer Editor, the Application Core uses the Live Media Switcher to change the active stream;

Ingest server When a worker stops streaming, the Application Core informs the Ingest Server, which processes and stores the video contribution.

5.2 Smart contract

The Smart Contract registers and validates all information relevant to the MOGPlay DApp, such as new events or videos, video classifications, and purchases. It is also responsible for identity registration on the blockchain. All users invoke or query the chaincode instantiated in the blockchain network through this identity. An identity can have different permission policies depending on the user type. For example, users must have previously purchased a video to access it. We present the following most critical functionality.

Event creation When a news agency creates a breaking news event, a new event object in the blockchain contains its name, associated tags, geolocation range, and event duration.

Start live stream When a worker starts recording a live video, a new blockchain transaction is registered, creating a new Video object containing information about its ownership, geolocation, and associated event.

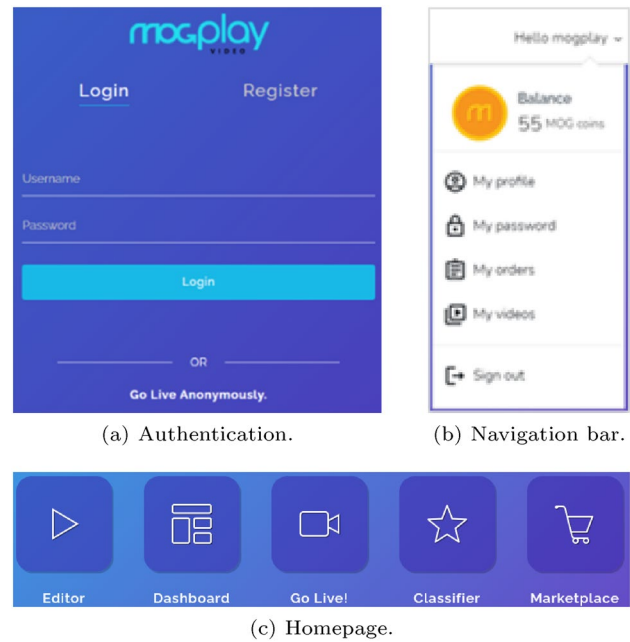

Fig. 4 MOGPlay entry interface to crowd journalism stakeholders

Stop live stream When completing a video capture, media operations generate the video assets (such as thumbnails, watermarked version, and the original video asset) and update the corresponding Video object in the blockchain with this new information.

Classify video When a user classifies a video, a transaction submitted to the ledger contains three rating parameters: impact, trustiness, and informative.

Set video price When workers finish the live stream, they define or update a price for the video published in the News Video Marketplace.

Publish or unpublish the video These functions show or hide videos from the News Video Marketplace, which will only display videos with a published price.

Search videos When a user searches for videos matching specific criteria, a query to the blockchain uses the world state to retrieve the desired set.

Purchase video When a marketplace user purchases a video, a new blockchain transaction request validates the balance to ensure the availability of enough credits. An authorized transaction grants access to the video asset and registers a new purchase object into the blockchain ledger with a predefined price. This transaction goes through the consensus mechanism to guarantee its truthfulness. Workers receive tokens for trading videos on the News Video Marketplace.

5.3 MOGPlay mobile app

This section presents the graphical interface of the MOG-Play mobile app for intuitive interaction with the citizens, news reporters, and news platform managers.

Authentication page All users use the same authentication form to log in, regardless of their role, as depicted in Fig. 4a. Citizens can either authenticate with their existing credentials (on the “Login” tab) or create a new account (on the “Register” tab), providing an email, a username, and a password. The Capture Module is the only component accessible without an account.

Homepage When users login into the platform with their credentials, they can access different functionalities depending on their permissions. For example, news platform managers can access all the application components through the platform’s homepage (see Fig. 4c). The parts with restricted access are the Editor and Dashboard. The Editor page restricts one journalist user per event, while the Dashboard is only available to the news platform managers. These two options are not visible to users without enough permission.

Navigation Bar It provides access to additional pages (see Fig. 4b).

My profile This page allows stakeholders to see their current wallet balance and profile data (including user type, email, blockchain identifier, and username), update their username, and delete their accounts;

My password This page allows stakeholders to update their account password;

My orders This page allows consumers to visualize their previous orders on the News Video Marketplace (e.g., video price, owner, publication date) and provides a shortcut to download the purchased videos;

My videos This page allows workers to visualize stream information, set the videos’ price, publish or remove them from the News Video Marketplace, or download them to their devices.

Multiviewer editor It enables news reporters to browse, watch live feeds, publish relevant feeds to external broadcast channels, such as YouTube Live, and communicate with the workers (see Fig. 5a) through three components.

Thumbnail sidebar It contains image previews of the feeds created by the workers, updated every few seconds. News producers can drag and drop each thumbnail into one of the four video players in the editing panel. They can also add or remove favorite users and sort the thumbnails by type, by favorites or by newest.

Editing panel It provides three features to news producers: (1) *watch* four simultaneous live feeds in near real-time (dragged from the thumbnail sidebar), (2) *select* live feeds for external broadcasts, and (3) *communicate* with

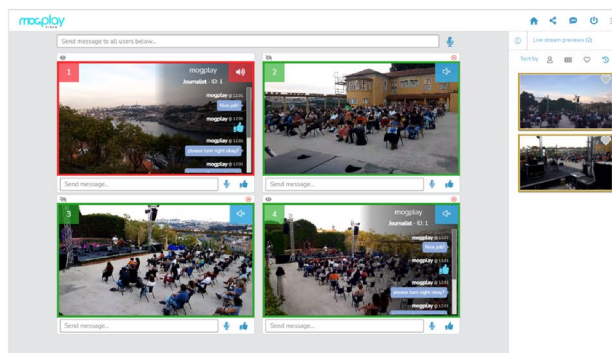

(a) Multiviewer Editor.

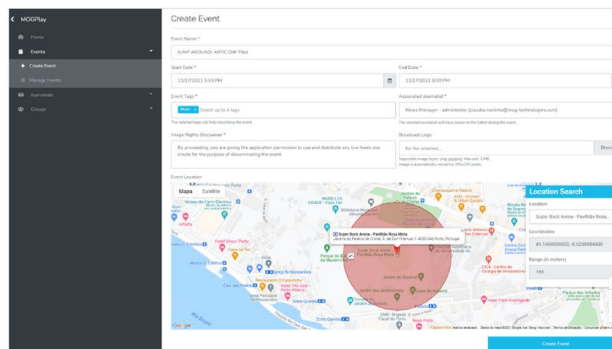

(b) Event creation.



(c) Journalist creation.

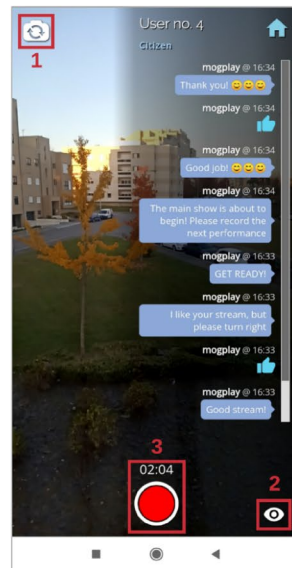

(d) Capture Module.

Fig. 5 MOGPlay video streaming interface

the live streaming users using text or short likes and journalists using audio messages.

Navigation bar offers the following options to the news producers: (1) *Homepage* to access the DApp; (2) *Publish settings* of the selected feed in the editing panel to external broadcast channels, such as YouTube Live; (3) *Messaging options* to customize the messaging system and disable individual messaging options; (4) *Sign out* of the application; and (5) *Collapse sidebar* and enlarge the video players to fit the new space.

Administration dashboard It enables news platform managers to create and manage events and professional users.

Event creation News platform managers can create events associated with an area of interest using the Google Maps interface displayed in Fig. 5b and start collecting live streams by specifying the event name, start and end dates, event tags, associated journalist, image rights disclaimer, and broadcast logo.

Journalist creation In Fig. 5c, the news platform manager creates new accounts for professional users by entering the email address, username, and journalist role (i.e., news reporter and news manager).

Capture module This module allows authenticated and anonymous users to capture audio and video using their mobile devices and stream it to the Cloud Platform. It also handles heterogeneous essence encoders available in the browser and selects the ones taking the best advantage of the available bandwidth. The streaming is disabled if the user is outside the event area, the event has yet to start or has already ended, and it displays an appropriate popup message. All users receive textual feedback from the editing room, motivating them to continue streaming. However, only journalists can receive audio messages from the editing room while capturing live videos. Figure 5d highlights the features available to all users that access this interface, comprising: 1. front/rear camera switch; 2. show/hide an overlay with received messages; 3. record streaming session and its duration; 4. mute/unmute audio during streaming.

The page also displays the authenticated usernames and the identifiers of anonymous users. Authenticated users access the other platform pages through a menu, while anonymous users can only choose a “home” icon to return to the authentication page.

Multiviewer classifier News reporters employ the Multiviewer Classifier for selecting videos, creating their perspectives of an event, and rating and classifying content based on preferences. Similarly to the Multiviewer Editor (see Fig. 5a, the page allows users to browse all live feeds and drag and drop them to the four available video players. Therefore, users can watch four simultaneous live videos showing different streaming perspectives. While watching a live feed, users can classify

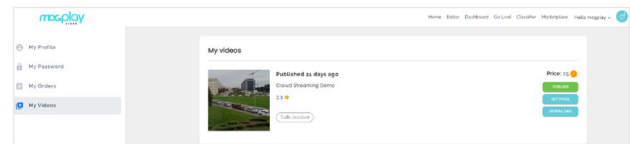

(a) My videos.

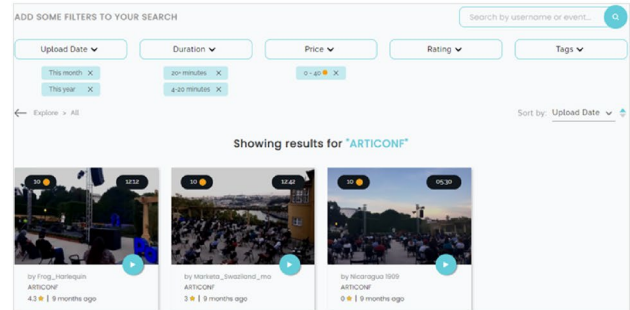

(b) News Video Marketplace.

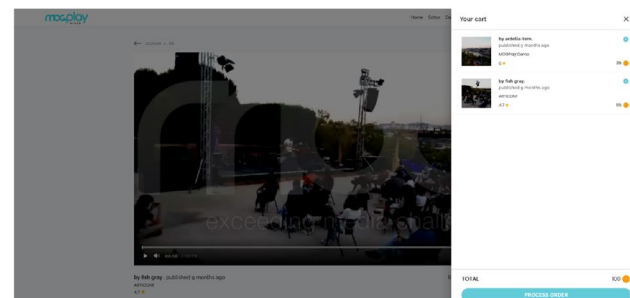

(c) Shopping cart.

Fig. 6 News Video Marketplace interfaces

the video content considering the impact, trustiness, and informativeness, rated on a scale from one to five. This page also enables adding and removing favorite users and sorting them according to different criteria, similar to the Multiviewer Editor.

News video marketplace The blockchain-based marketplace allows users to create, produce, and trade videos in a secure, decentralized, and democratic fashion with ensured anonymity and ownership. This compensation mechanism encourages citizens to adopt the MOCPLAY DApp despite other well-established social media platforms. The page depicted in Fig. 6a allows the workers to publish or unpublish videos from the News Video Marketplace and update their selling price. The main page depicted in Fig. 6b enables easy and quick video searching using multiple dropdown filtering and sorting criteria, including upload date, video duration, price, average rating, and event tags. Users can filter marketplace results by selecting the username or event in each video card. Figure 6c displays the shopping cart with information about the enclosing videos and their total price. The cart allows users to remove videos and process their orders. If the consumer has enough tokens to complete the order, the

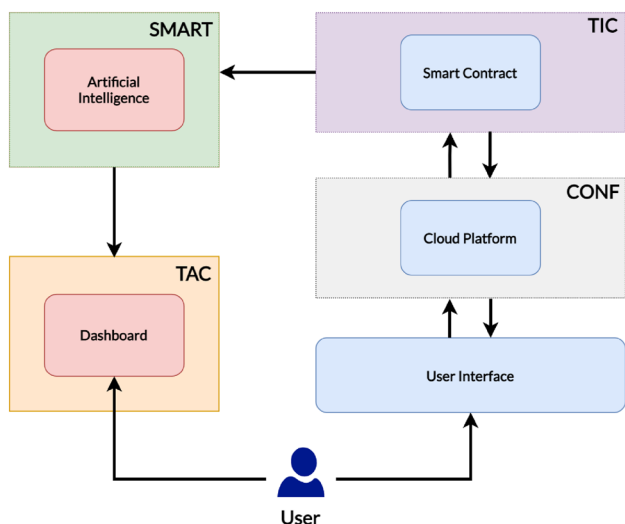
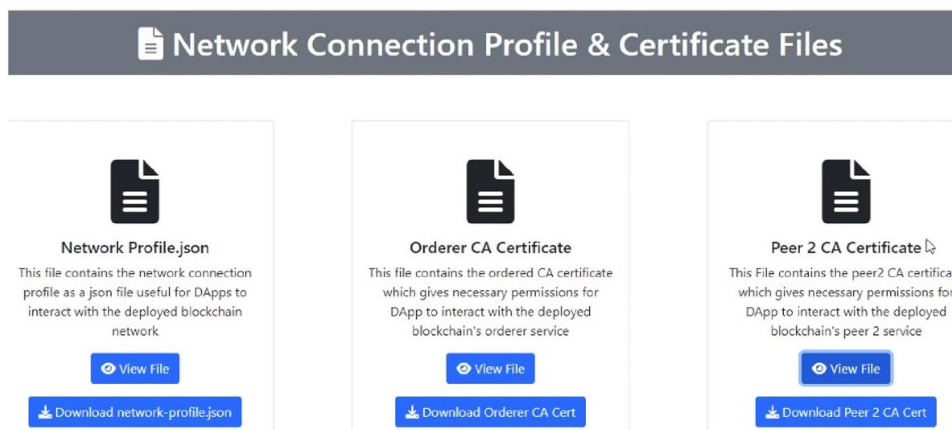

Fig. 7 MOGPlay and ARTICONF tool integration

Fig. 8 Blockchain configuration dashboard



transaction completes, transfers the tokens to the video owner, and updates the remaining user tokens.

6 ARTICONF tools for crowd journalism

Figure 7 displays the integration of the MOGPlay DApp with the ARTICONF platform and operational tools.

6.1 TIC

The MOGPlay DApp uses the Cloud-agnostic tool offered by TIC for blockchain deployment for increased outreach to trustworthy stakeholders (e.g., citizens and news reporters) in the crowd journalism marketplace. Additionally, TIC facilitates an advanced environment for the MOGPlay DApp providers and developers to quickly deploy and

configure a secure crowd journalism network with several advantages.

Automated customization MOGPlay automatically configures the permissioned blockchain network with reduced time and complexity (see Fig. 8) in two steps: (1) a network profile architecture description of the number of peers and orderers, and (2) a secure connection and operation on the blockchain through two certificates.

Smart contract implementation MOGPlay enables secure live streaming of news content and corresponding metadata, using the relationship system to integrate the generated certificates and perform blockchain transactions easily.

High-throughput MOGPlay enables news content generation and trading of blockchain transactions through the storage module handling a large and continuous stream of incoming data and information securely, encrypted, and recorded using the content identifier only.

Online visualization MOGPlay collects visual feedback on the traceability of executed news content transactions

across the MOGPlay blockchain network in real time, governed by a uniform set of policies implemented via smart contracts to ensure the same level of security, privacy, and trust.

MOGPlay stakeholder federation It implements a decentralized blockchain consortium of citizens, news reporters, and news platform managers with guaranteed consistency, accountability, and traceability of news content creation, sharing, and propagation. Additionally, TIC facilitates the integration of third-party authentication providers with a unique, verified identity in the MOGPlay federation. TIC uses fault-tolerant consensus algorithms to achieve soft real-time agreement among various news platform managers, which is crucial for large-scale crowd journalism services handling multiple and frequent streams of news content production supply chains.

Relationship system It is a Turing-complete blockchain component. It enables MOGPlay stakeholders to set news content sharing and rights conditions through smart contracts, giving them complete control over their content. TIC also generates a membership agreement between citizens, news reporters, and news platform managers to establish secure communication with the MOGPlay network and access authorized news content in persistent Cloud storage.

MOGPlay certificate authority It is a client-side software development kit that issues certificates to MOGPlay stakeholders, encrypting sensitive news content before broadcasting and persisting it on the blockchain and Cloud storage.

6.2 CONF

CONF is a tool for customizing a Cloud infrastructure for the MOGPlay microservices considering specific crowd journalism requirements:

1. High news media streaming throughput (of 100Mbit/s) during video ingestion;
2. On-demand provisioning and deployment of resources for dynamically increasing number of marketplace users;
3. Monitoring and visualization of resources, services, and DApp metrics for the high quality of experience (QoE) to MOGPlay users.
4. Performance anomaly and root cause detection to maintain the smooth operation of the MOGPlay microservices.

Infrastructure description CONF provides an interface to describe the MOGPlay microservice (e.g., news video ingestion, selection, transcoding) requirements for deployment. Based on this description, it generates a plan for the underlying virtual infrastructure running a DApp instance. For example, a generated plan can contain two VMs acting as nodes in a Kubernetes cluster and an NFS server for data persistence. The developer can modify the plan, add more VMs or change their properties, such as the number of cores and memory size.

Infrastructure provisioning The MOGPlay DApp developer uses CONF to provision the infrastructure resources (e.g., VM, network) on selected Cloud providers. CONF also automates the platform installation, such as Kubernetes and the NFS server, required by MOGPlay.

DApp deployment CONF deploys MOGPlay microservices (e.g., media ingestion, transcoding), resolves their dependencies, and configures their auto-scaling thresholds. Afterward, it validates the microservices by ensuring an accessible interface and dashboard URL endpoints to news platform managers and MOGPlay DApp developers. Finally, CONF returns all the infrastructure attributes, such as the

VMs' public IP addresses and the deployed MOGPlay DApp URL endpoints, including its monitoring services.

Monitoring and performance diagnosis After provisioning and deployment, CONF monitors various runtime metrics of Cloud infrastructure (i.e., CPU, memory, network) and presents the information to the DApp developer using a graphical dashboard (see Fig. 9). CONF processes the aggregated data using ensembles of machine learning (ML)-based anomaly detection and root cause analysis models and proactively detects performance abnormalities in the MOGPlay DApp and blockchain network (e.g., news content-related transaction failures, lower throughput) in the next four minutes with an F1 score higher than 0.8. If necessary, it takes corrective actions to prevent the failure or congestion of MOGPlay microservices for a fluent QoE. CONF uses causal inference and graph theory techniques to accurately discover anomaly propagation paths and the root cause, which enables the DApp developers to take appropriate actions, such as scaling resources, resolving performance anomalies, and maintaining the smooth operation of the MOGPlay microservices.

6.3 SMART

The SMART tool retrieves, parses, and analyzes the crowd journalism information stored on the MOGPlay blockchain federation. SMART uses immutable content traces embedded within the blockchain network to provide a semantic mapping that captures thematic mismatches between news consumption and creation activities. Such contextual mapping enables the crowd journalism marketplace to enhance news consumption by discovering and grouping content based on thematic context (e.g., politics, movies, climate, sports). Additionally, SMART's proactive event-based clustering enables the marketplace to identify semantically similar pseudonym user groups based on news type and consumption preferences. It also personalizes content recommendation and predicts the news consumption of thematic contexts. SMART further provides trust metrics for news content authenticity and pseudonym user reputation, facilitating user-level decision-making and trustworthy and authenticated content creation, management, and propagation.

SMART user To achieve these goals, SMART integrates with the TIC tool that initializes a "SMART user" with each instantiated blockchain network handling access permission of user data for analytic purposes. The SMART user initiates a request to pseudonym users to access encrypted data associated with their transactional activities (e.g., content creation, view, purchase). Upon getting access permissions, the SMART user pushes the gathered data to the SMART tool using a RESTful API, which allows decentralized analysis of transactional activities without privacy violation with

Fig. 9 CONF monitoring dashboard

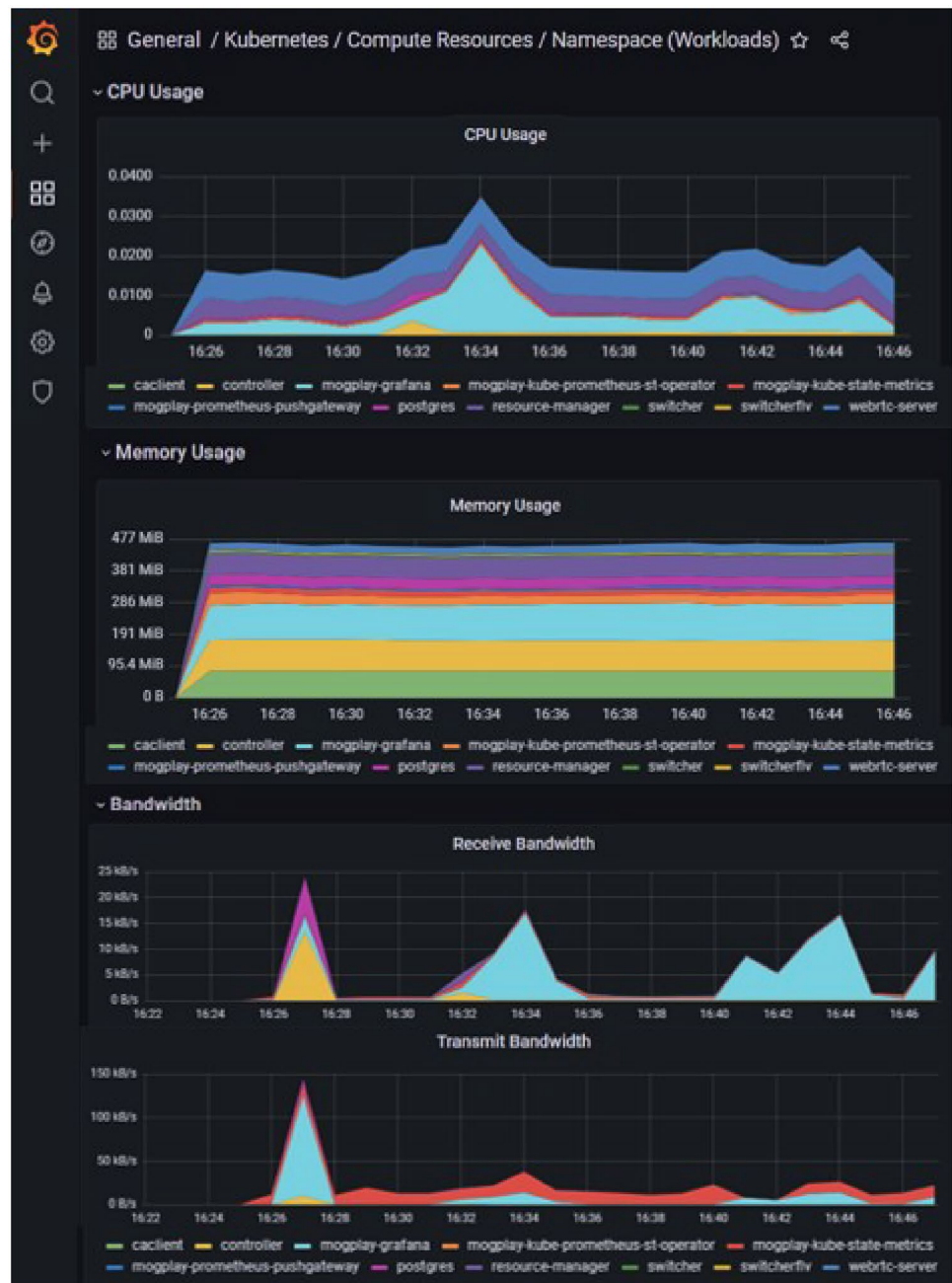

important stakeholder benefits, presented in the following paragraphs.

Contextual thematic news grouping SMART integrates a multilayer contextualized semantic linking microservice (Kivelä et al. 2014) that splits semi-structural transactional blockchain data into unique contexts (e.g., politics, movies, sports) based on popularity, demand, and consumption pattern. Furthermore, SMART clusters contextualized news content transactions with similar properties using the augmented OPTICS (Ankerst et al. 1999) (e.g., politics, movies, creation timestamp). For example, within a thematic news content context, an explanatory cluster could span over

an international politics theme IP in a country C. Hence, the cluster of pseudonym users performing transactions receives a label IP-C.

Crowd journalism event prediction SMART partitions the labeled cluster groups into multiple temporal time windows that allow the discovery of cluster evolution (e.g., continuing, growth, shrinkage) chains over time, capturing behavioral patterns in news creation and consumption. For this purpose, it employs six ML classification techniques (i.e., naïve Bayes (NB) (Takaffoli et al. 2014), support vector machines (SVM) (Dakiche et al. 2019), k-nearest neighbors (KNN) (Saganowski et al. 2019), boosting, decision trees

(DT) (Takaffoli et al. 2014), random forest (Saganowski et al. 2019) (RF)) for crowd journalism event prediction, allowing the news marketplace to recommend personalized content for consumption based on past behavior.

Trustworthy news management SMART employs a decision-making methodology that engages citizens, news reporters, and news platform managers in content voting and classifying trustworthy news (Saurabh et al. 2022). It employs authenticity ratings for news content and a rescaled sigmoid model (Ren et al. 2007) to compute the citizens' reputation ratings. SMART associates each user with a contextualized *local reputation* reflecting the trust in news creation within the same context (e.g., politics, sports, movies). In contrast, the *global reputation* provides enhanced weighted trust ratings of a user across all contexts of the crowd journalism marketplace. Such a design allows fair and democratic decision making for content trust management and prevents infinite accumulation of reputation by any user.

News popularity classification Citizens and news reporters use SMART's contextual grouping and cluster evolution prediction methods to decide the type of news videos to create at the crowd journalism marketplace. Consequently, crowd journalism campaigns initiated by news platform managers can focus on a suitable set of news videos to reach a broader audience without analyzing the activity history of individual citizens or news reporters. To demonstrate this functionality, we run a simulation using a real-world video dataset from Kaggle⁷ containing ten top trending video lists per country with events such as the number of likes, dislikes, and views. Figure 10a visualizes video news popularity clusters (i.e., none, low, moderate, many likes) between week 47 and 48, where the cluster diameter indicates its size. Interestingly, many videos reached the trending page without any likes and are part of the empty *continuing cluster none* with the largest size. The clusters with many and moderate likes are *shrinking*, indicating that news videos with low likes have a higher chance of reaching trending. Consequently, crowd journalism news platform managers can also add advertisements to news videos receiving 300–400 likes, as they are more likely to reach trending and narrow down the trending candidates. Similarly, the news platform managers use SMART to predict news *category cluster evolution*, which helps citizens and news reporters proactively decide the topics for creating news videos to reach trending easier. Figure 10b evaluates the news popularity cluster evolution prediction using the six ML classifiers and their principal component analysis versions, denoted as NB*, SVM*, KNN*, DT*, RF*, and boosting*, compared to baseline majority class (Thomason et al. 2018), and persistence (Bludszuweit et al. 2008)) ML

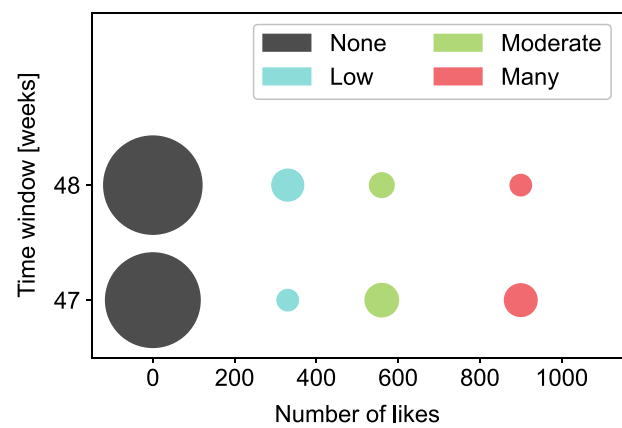

(a) Cluster evolution over time.

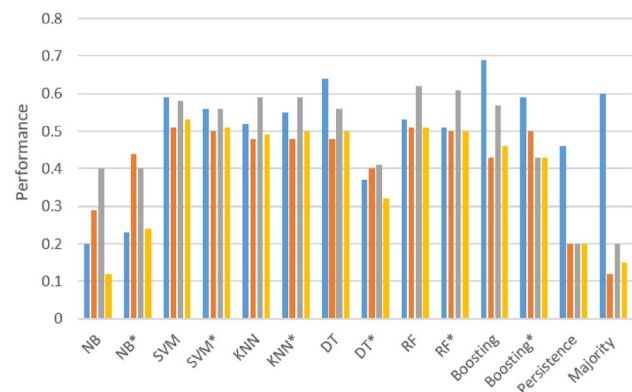

(b) Cluster evolution prediction.

Fig. 10 News popularity classification and evolution in crowd journalism

methods. The results show that RF- and SVM-based models achieved the best accuracy (57% and 59%), precision (52%, and 55%), recall (59% and 65%), and F1 score (50% and 55%), with up to three times improvement over baseline predictions.

6.4 TAC

TAC aggregates the contextualized information generated by the SMART tool and presents it on a user-friendly dashboard. TAC develops geospatial, temporal, return on investment, return on collaboration, visualization, and guided analytic microservices that help to meet specific crowd journalism criteria and requirements, such as:

1. Identify locations with the most engagement;
2. Overview the history of created and purchased videos to understand user activities;
3. Identify successful videos creators and influencers in the crowd journalism network;

⁷ <https://www.kaggle.com/datasnaek/youtube-new>.

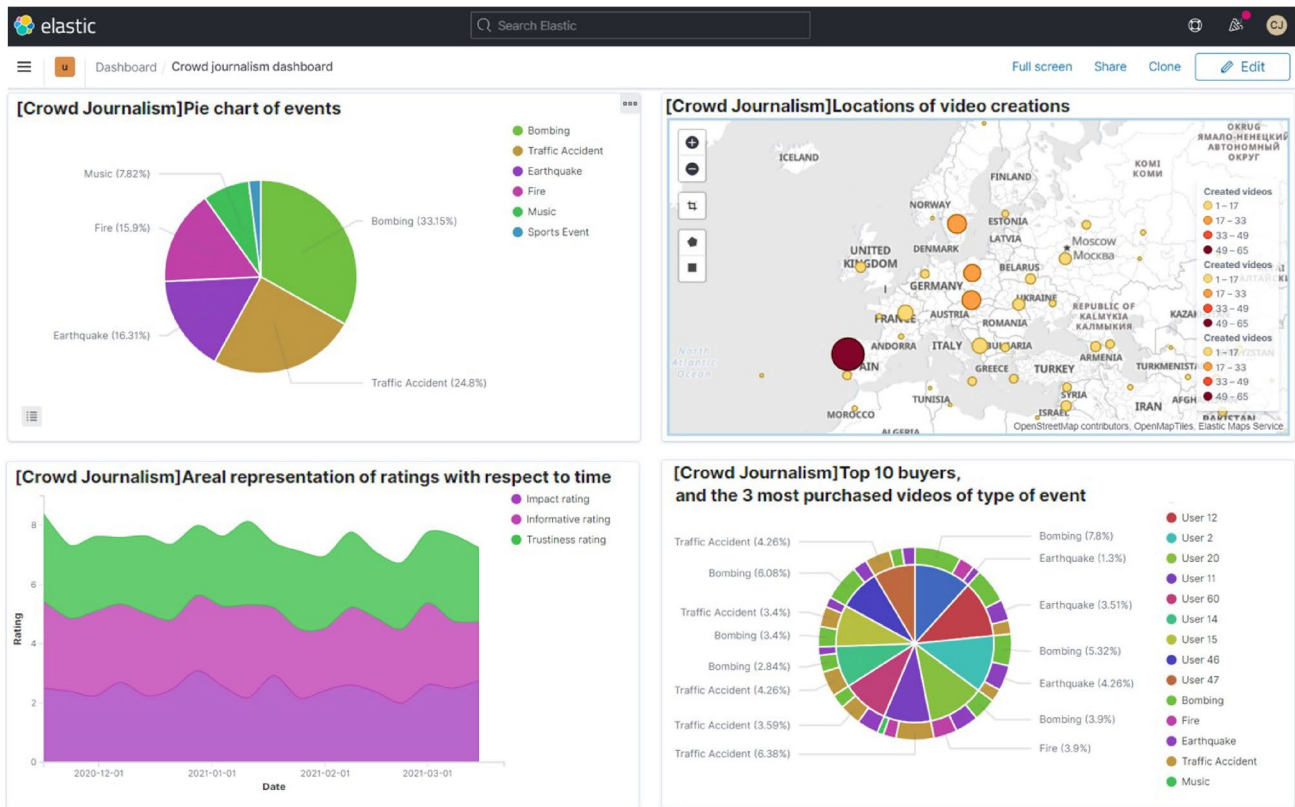

Fig. 11 Geospatial and temporal dashboard for crowd journalism statistics

4. Visualize event registration and login statistics over time.

Initially, TAC aggregates the data flow obtained by the SMART tool and fits it in the corresponding microservice group based on the content and format. Each microservice uses its mechanism to interpret and analyze the data matching it with the specific crowd journalism requirements. The outcome of this process is a visual interactive guided analytic dashboard exporting valuable insights to expand and strengthen the business activities and profits and improve users’ QoE using an efficient and meaningful information transfer from the machine to the human brain. The news platform managers can perform various reorganization, filtering, analysis, and visualization activities over the dashboard data. TAC provides three dashboards for crowd journalism.

Geospatial and temporal dashboard Fig. 11 shows a dashboard covering four significant guided analytics insights conducted using SMART on the crowd journalism marketplace:

- *Crowd journalism events* presents a set of contextualized news and a percentage of related marketplace videos.

- *Geoprofiling video capture and creation* visualizes the geolocation of videos created for different news events.
- *Marketplace ratings* provides a temporal analysis of the cumulative impact (i.e., citizens outreach and views), informative (i.e., citizen endorsement), and trust (i.e., authenticity) ratings of all news events and videos;
- *Buyers and video purchase trends* provides a visual analysis of the top ten video buyers and the three most popular crowd journalism event videos purchased on the marketplace.

Predictive community dashboard It represents insights provided using ML techniques over predefined communities, such as the video popularity cluster evolution prediction in Fig. 10b.

Business revenue dashboard This dashboard shown in Fig. 12 tracks the trend of crowd journalism business revenue progress through:

- *Engagement rate* representing the ratio between the current video price (in tokens) and total price (aggregated tokens of all purchases) and providing insights into ROC, depending on the current price of the video and the total price of all video purchases.

Fig. 12 Business revenues dashboard for crowd journalism



- ROI depending on the current and the purchased video prices.

7 Crowd journalism validation pilots

This section presents three validation pilots conducted to explore the use of MOGPlay DApp for live coverage of

Fig. 13 Porto Book Fair event coverage

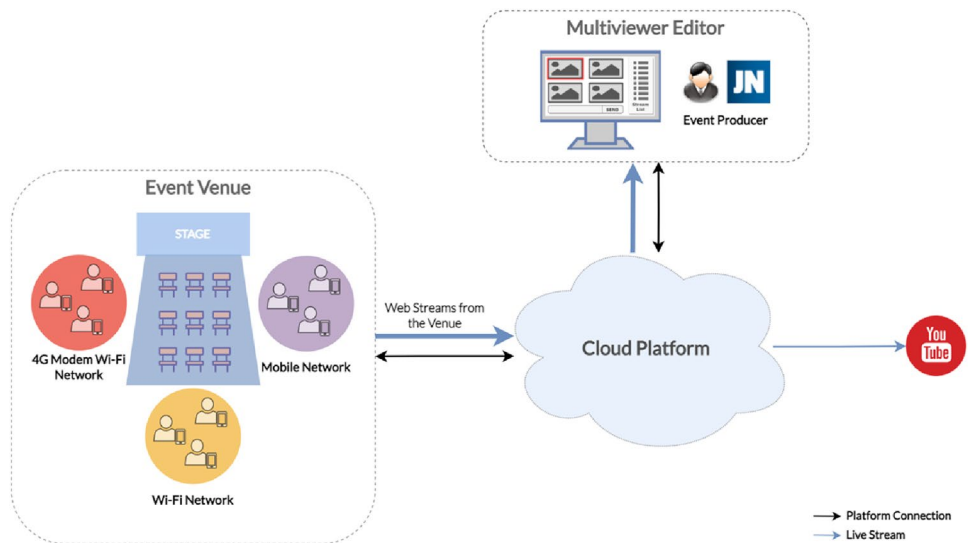

(a) Book Fair pilot workflow.



(b) Capture Module (citizens).



(c) Multiviewer Editor (reporters).

Fig. 14 MOGPlay monitoring interface during the Porto book fair pilot

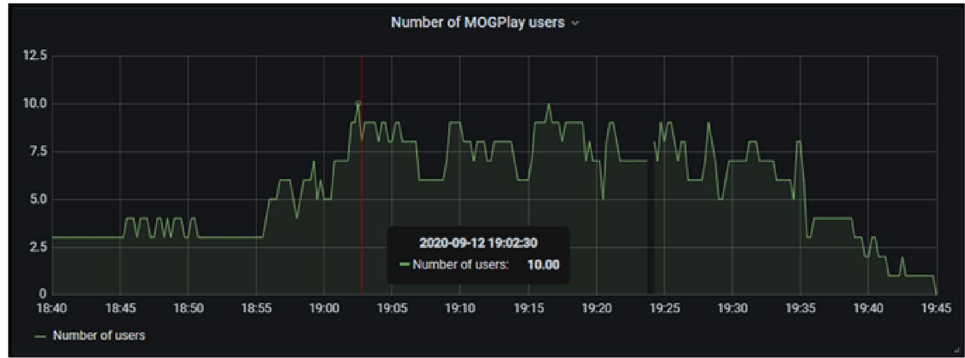

(a) Number of live feeds.

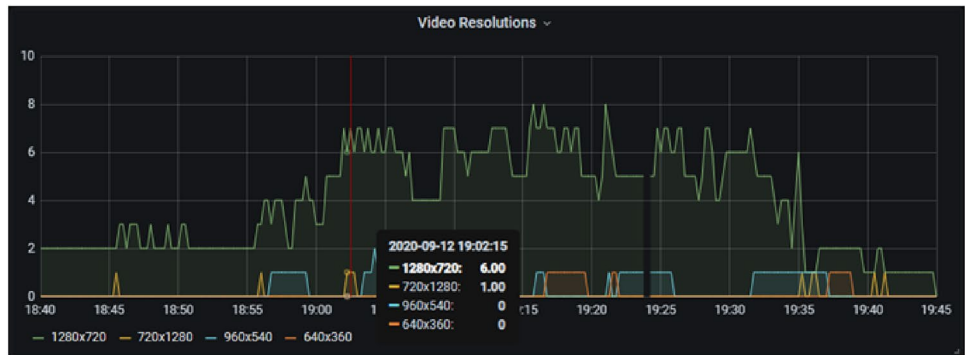

(b) Number of live feeds.

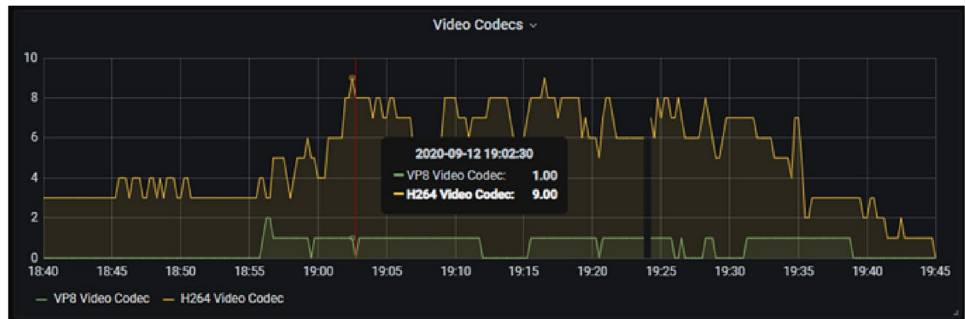

(c) Number of live feeds.

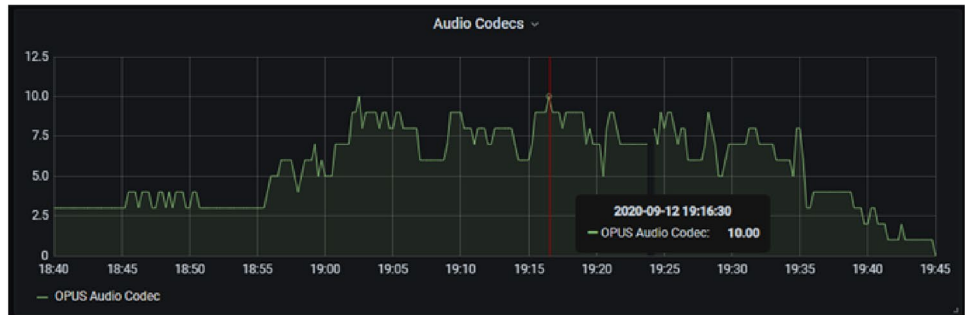

(d) Number of live feeds.



(a) Marathon live snapshots.

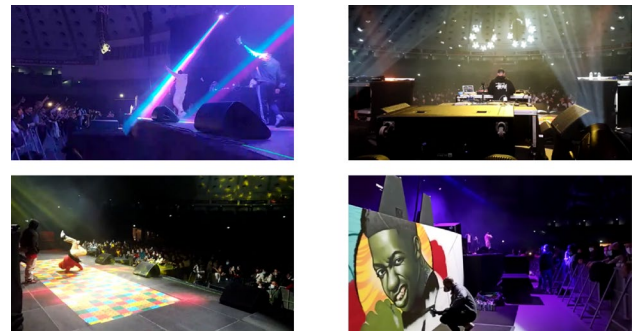

(a) Live concert snapshots.



(b) HELIOS CJ Reporter and MOGPlay apps.



(b) Flyer.



(c) MPGPlay – HELIOS CJ Reporter workflow.

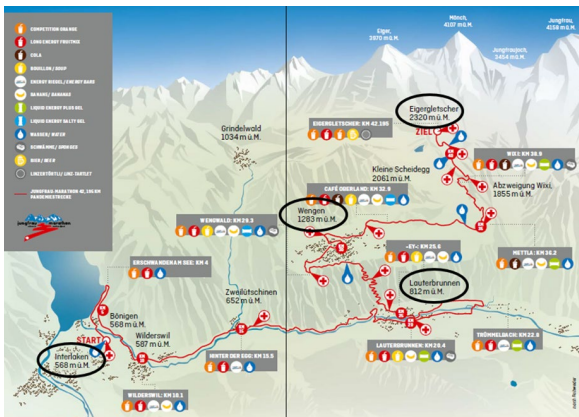

(c) Capture locations.

Metric	Result
Number of live concert streams	122
Number of trial citizens	13
Number of simultaneous live citizens	5
Total concert footage	7 h 15 min

(d) Live coverage metrics

Metric	Result
Number of live streams	173
Number of trial citizens	11
Number of simultaneous live citizens	6
Total marathon footage	6 h 24 min
YouTube live stream views	51

(d) Marathon live coverage metrics.

Fig. 15 Jungfrau Marathon event coverage

public events with complementary social profiles: cultural (Porto Book Fair), sportive (Jungfrau Marathon and championship football match), and entertainment (Jump Around hip-hop concert). Sanitary and social distancing rules imposed by the COVID-19 pandemic constrained some of the pilots to smaller citizen participation and limited the validation scale.

Fig. 16 Jump around event coverage

7.1 Porto book fair

The first pilot took place at the 2020 Porto Book Fair, held annually at Jardins do Palácio de Cristal and featuring a series of outdoor concerts at the Terreiro da Casa do Roseiral. The pilot covered the show of the Retimbrar musical artist following the workflow depicted in Fig. 13a. Figure 13b displays trial participants using the Capture Module on their smartphone to create live videos, stream to the Cloud Platform, and send them to the Multiviewer Editor. The production of the event’s footage involved technicians and journalists from the Jornal de Notícias (Portuguese newspaper), who used the Multiviewer Editor on a high-end backstage computer to preview the live event footage with high QoE, communicate with the streamers and commute among videos broadcasted to YouTube Live (see Fig. 13c). MOGPlay offers a rich set of monitoring charts that help news platform managers monitor important metrics during the operation of an event, such as the number of processed feeds (Fig. 14a), the acquired video resolutions (1280 × 720 and 720 × 1280

Fig. 17 Football match event coverage

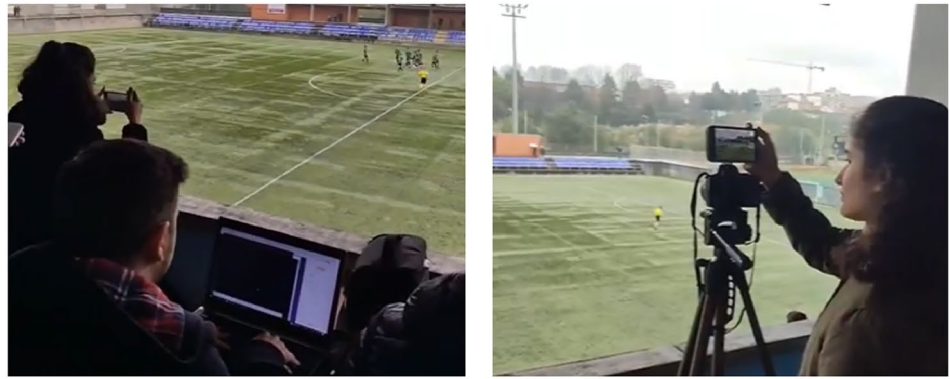

(a) News reporters (left) and citizens (right).

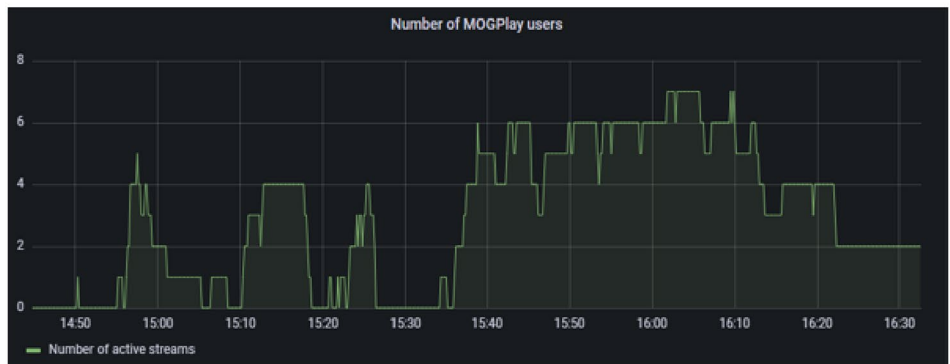

(b) Number of simultaneous users.

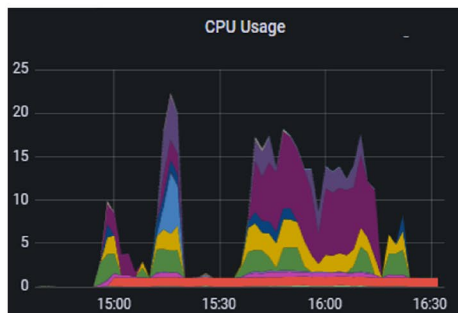

(c) CPU use.

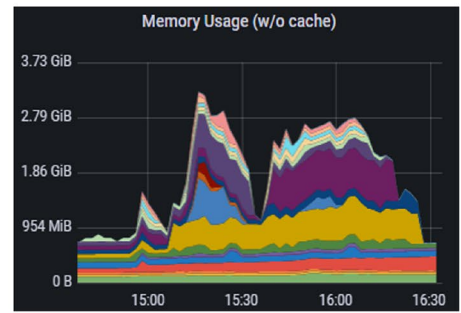

(d) Memory use.

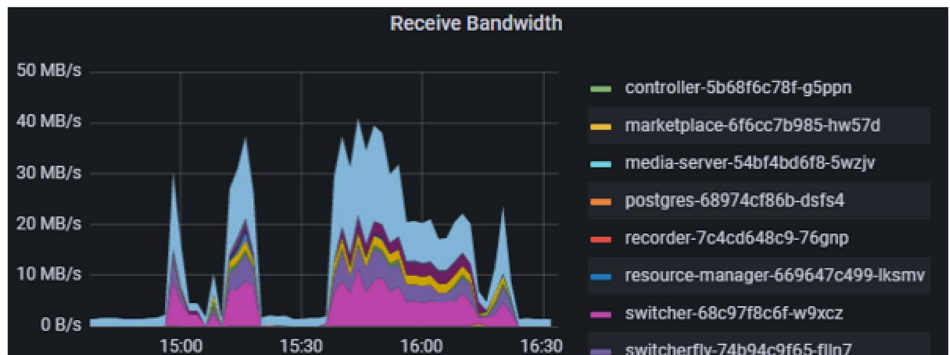

(e) Bandwidth use.

in Fig. 14b), the video codec (H.264 and VP8 in Fig. 14c) and the audio codec (OPUS in Fig. 14d).

7.2 Jungfrau Marathon

The second pilot covered the 28th Jungfrau Marathon in Interlaken spanning over 40 km and an altitude difference of 1829m on the famous Eiger, Mönch, and Jungfrau mountains of the Swiss Alps. During the marathon, the trial participants captured footage of a blind celebrity called Chantal Cavin, a former world record holder in swimming and triathlete, well recognized in the Swiss sports community (see Fig. 15b). The goal of the joint coverage was to propose a unified crowd journalism solution to stakeholders that extends the CJ Reporter with MOGPlay media capture, streaming, curation, and editing functionality (see Fig. 15a). The citizens used public transportation to capture the footage in four locations (see Fig. 15c): Interlaken (start line), Lauterbrunnen, Wengen, and Eigergletscher (finish line). The event coverage was a collaboration with the SWISS TXT subsidiary and the center of multimedia expertise of the Swiss Broadcasting Corporation. SWISS TXT operates a similar tape-based crowd journalism app called HELIOS *CJ Reporter* that allows citizens to record content for the broadcasting company using their smartphones. Table 15d summarizes the monitoring metrics resulting from the marathon coverage. A summary of the extensive YouTube coverage of the marathon is available at <https://www.youtube.com/watch?v=iGk90k77HDY>.

7.3 Jump around concert

The third pilot covered the Jump Around event at the Superbock Arena in Porto, a Portuguese show of over three hours, hosting the most renowned national hip-hop artists uniting its four pillars: rapping, DJing, breakdancing, and graffiti. The aim was to promote different aspects of this cultural movement with the most significant expression among the young public. The participants captured live videos using the CJ Reporter or MOGPlay apps (see Fig. 16a) and sent them to the Cloud Platform and the Multiviewer Editor (see Fig. 15a). This interface enabled the event producer to preview the live footage of the event, switch the video shown on the output stream, communicate with the streamers, and broadcast the output stream on a private YouTube Live channel (see Fig. 16c). Table 16d summarizes the parameters defined to monitor the performance of the crowd journalism pilot during the Jump Around concert. The feedback concerning the unique lighting, sound, and crowd-gathering challenges was positive too. Although the event organizers prohibited a public broadcast, a short video summary of the

coverage is available at <https://www.youtube.com/watch?v=eWsRT7yrSEQ>.

7.4 Championship football match

The final crowd journalism pilot covers a football championship match in Gaia, Portugal, between the Clube Desportivo Candal and Sport Clube Os Dragões Sandinenses teams of the Pro-national Series 1 2022/23. The pilot tested the final refinements in the MOGPlay DApp since the previous pilots and disseminated its features to potential stakeholders for future exploitation. We explored MOGPlay's potential to integrate professional news production (Fig. 17a, left) and citizen streams (right) for full match coverage from various perspectives, including flash player interviews complying with standard media procedures. Overall, the TIC and CONF successfully adjusted the blockchain configuration and deployment according to the needs during the match, and the resulting metrics follow the trend in the number of simultaneous streams. The highest CPU use is the result of the transcoding tasks (Fig. 17c), scaled vertically according to the number of users (Fig. 17b) to ensure a responsive experience. The memory use is neglectable (Fig. 17d), and the bandwidth accompanies the number of streams, never creating a bottleneck in the data flow (Fig. 17e). A mobile router used to cover the event recorded a streaming bandwidth of 1.25MB/s, representing an overall consumption of 36.3GB for the complete 120 minute event, representing an average of 8GB per citizen. A section of the stream coverage is available at <https://www.youtube.com/watch?v=VazV3vus5XI>.

8 Conclusion

We presented in this article a novel DApp for crowd journalism called MOGPlay that provides a novel strategy for collaborative news production. MOGPlay exploits the ARTI-CONF project tools and ecosystem for decentralized joint media production, enabling secure live news video capture, streaming, editing, and trade. We presented the use of MOGPlay DApp in four crowd journalism scenarios capturing live cultural, sportive, and musical events, illustrating its potential to animate the media and journalism industries in a dynamic, rewarding, and trustworthy ecosystem, motivational to all involved stakeholders. The following steps involve defining adequate business models for deployment and commercialization among media stakeholders. MOG Technologies will further explore the MOGPlay DApp in the PLAYOFF project, funded by the Portuguese National Innovation Agency.

Acknowledgements This work received funding from: European Union's Horizon 2020 research and innovation program, grant agreement 825134 (ARTICONF project); Portuguese National Innovation Agency, grant agreement NORTE-01-0247-FEDER-046553 (PLAY-OFF project).

Author contributions All authors reviewed the manuscript

Funding Open access funding provided by University of Klagenfurt.

Open Access This article is licensed under a Creative Commons Attribution 4.0 International License, which permits use, sharing, adaptation, distribution and reproduction in any medium or format, as long as you give appropriate credit to the original author(s) and the source, provide a link to the Creative Commons licence, and indicate if changes were made. The images or other third party material in this article are included in the article's Creative Commons licence, unless indicated otherwise in a credit line to the material. If material is not included in the article's Creative Commons licence and your intended use is not permitted by statutory regulation or exceeds the permitted use, you will need to obtain permission directly from the copyright holder. To view a copy of this licence, visit <http://creativecommons.org/licenses/by/4.0/>.

References

- Ankerst M, Breunig MM, Kriegel H-P, Sander J (1999) OPTICS: ordering points to identify the clustering structure. *ACM SIGMOD Rec* 28(2):49–60
- Antonopoulos N, Lamprou ED, Kiourexidou M, Konidaris A, Polykalis S (2020) Media websites services and users subscription models for online journalism. *Media Watch* 11(2):310–322
- Benet J (2014) IPFS-content addressed, versioned, P2P file system. [arXiv:1407.3561](https://arxiv.org/abs/1407.3561), July
- Bielenberg A, Helm J, Gentilucci A, Stefanescu D, Zhang H (2012) The growth of Diaspora—a decentralized online social network in the wild. In: *INFOCOM Workshops*, pp 13–18. IEEE, Mar
- Bludszuweit H, Dominguez-Navarro JA, Lombart A (2008) Statistical analysis of wind power forecast error. *IEEE Trans Power Syst* 23(3):983–991
- Borger M, van Hoof A, Sanders J (2019) Exploring participatory journalistic content: objectivity and diversity in five examples of participatory journalism. *Journalism* 20(3):444–466
- Dakiche N, Tayeb FB-S, Slimani Y, Benatchba K (2019) Community evolution prediction in dynamic social networks using community features' change rates. In: *34th ACM/SIGAPP symposium on applied computing*. ACM, pp 2078–2085
- Destabelle G (2019) Through a review of the main improvements of the blockchain and an analysis of the steem's model and token creation, how viable is the steem model compared to the bitcoin and what impact has the steem's inflation on its price?.
- Diakopoulos N, Naaman M (2011) Towards quality discourse in online news comments. In: *Conference on computer supported cooperative work*, ACM pp 133–142
- Engelke KM (2019) Online participatory journalism: A systematic literature review. *Media Commun* 7(4):31–44
- Guidi B, Michienzi A, Ricci L (2020) Steem blockchain: mining the inner structure of the graph. *IEEE Access* 8:210251–210266
- Guidi B, Michienzi A, Ricci L (2021) A graph-based socioeconomic analysis of steem. *IEEE Trans Comput Soc Syst* 8(2):365–376
- Hunter A (2021) *Crowdfunding and crowdsourcing in journalism*. Routledge, London
- Karadimce A, Bogatinoska DC, Sefidansoki M, Dimoska NP, Marina N (2020) Tools for analytics and cognition framework for a car-sharing use case. In: *43rd international convention on information communication and electronic technology (MIPRO)*. IEEE, pp 954–959
- Kivelä M, Arenas A, Barthelemy M, Gleeson JP, Moreno Y, Porter MA (2014) Multilayer networks. *J Complex Netw* 2(3):203–271
- Liu M, Gehl RW, Zulli D (2020) Rethinking the 'social' in 'social media': insights into topology, abstraction, and scale on the mastodon social network. *New Media Soc* 22:1188–1205
- Palomo B, Teruel L, Blanco-Castilla E (2019) Data journalism projects based on user-generated content. How la nacion data transforms active audience into staff. *Digit J* 7(9):1270–1288
- Panagiotidis K, Tsipas N, Saridou T, Veglis A (2020) A participatory journalism management platform: design, implementation and evaluation. *Social Sciences* 9(2):1–15
- Prodan R, Saurabh N, Zhao Z, Orton-Johnson K, Chakravorty A, Karadimce A, Ulisses A (2019) ARTICONF: Towards a smart social media ecosystem in a blockchain federated environment. *Euro-Par 2019: parallel processing workshops*, vol 11997. Springer, New York, pp 417–428
- Raman A, Joglekar S, Cristofaro ED, Sastry N, Tyson G (2019) Challenges in the decentralised web: the Mastodon case. In: *Proceeding of the internet measurement conference*. ACM, pp 217–229
- Ren J, McIsaac KA, Patel RV, Peters TM (2007) A potential field model using generalized sigmoid functions. *IEEE Trans Syst Man Cyberne Part B (Cybernetics)* 37(2):477–484
- Rossaro A, Surquin C (2019) Supporting the Portability of Profiles using the Blockchain in the Mastodon Social Network. PhD thesis, Louvain School of Engineering
- Saganowski S, Bródka P, Koziarski M, Kazienko P (2019) Analysis of group evolution prediction in complex networks. *PLoS ONE* 14(10):1–18
- Saridou T, Panagiotidis K, Tsipas N, Veglis A (2019) Designing and implementing a participatory journalism management platform. In: *Future of journalism conference: innovations, transitions and transformations*
- Saurabh N, Herold M, Fard HM, Prodan R (2022) SMART: A tool for trust and reputation management in social media. In: *Euro-Par 2021: parallel processing workshops*, vol 13098. Springer, pp 417–427
- Spyridou LP (2019) Analyzing the active audience: reluctant, reactive, fearful, or lazy? forms and motives of participation in mainstream journalism. *Journalism* 20(6):827–847
- Takaffoli M, Rabbany R, Zai'ane O. R (2014) Community evolution prediction in dynamic social networks. In: *International conference on advances in social networks analysis and mining (ASONAM 2014)*. IEEE, pp 9–16
- Thomason J, Gordon D, vBisk Y (2018) Shifting the baseline: Single modality performance on visual navigation & QA. [arXiv:1811.00613](https://arxiv.org/abs/1811.00613)
- Xu Q, Song Z, Goh R. S. M, Li Y (2018) Building an ethereum and IPFS-based decentralized social network system. In: *24th International conference on parallel and distributed systems*, IEEE, pp 986–991
- Zignani M, Gaito S, Rossi G. P (2018) Follow the “Mastodon”: Structure and evolution of a decentralized online social network. In: *12th international AAI conference on web and social media*. AAAI Press, pp 541–550
- Zignani M, Quadri C, Gaito S, Cherifi H, Rossi G. P (2019) The footprints of a “Mastodon”: How a decentralized architecture influences online social relationships. In: *Conference on computer communications workshops*. IEEE, pp 472–477

Publisher's Note Springer Nature remains neutral with regard to jurisdictional claims in published maps and institutional affiliations.