



**Aalborg Universitet**

**AALBORG UNIVERSITY**  
DENMARK

## **Experience with the Notch Stress Approach for Fatigue Assessment of Welded Joints**

Pedersen, Mikkel Melters; Mouritsen, Ole Ø.; Hansen, Michael Rygaard; Andersen, Jes G.

*Published in:*

Proceedings of Swedish Conference on Lightweight Optimised Welded Structures, LOST

*Publication date:*  
2010

*Document Version*  
Publisher's PDF, also known as Version of record

[Link to publication from Aalborg University](#)

*Citation for published version (APA):*

Pedersen, M. M., Mouritsen, O. Ø., Hansen, M. R., & Andersen, J. G. (2010). Experience with the Notch Stress Approach for Fatigue Assessment of Welded Joints. In Z. Barsoum, & J. Samuelsson (Eds.), *Proceedings of Swedish Conference on Lightweight Optimised Welded Structures, LOST* Kungliga Tekniska Högskolan. TRITA-AVE 2010:23

### **General rights**

Copyright and moral rights for the publications made accessible in the public portal are retained by the authors and/or other copyright owners and it is a condition of accessing publications that users recognise and abide by the legal requirements associated with these rights.

- ? Users may download and print one copy of any publication from the public portal for the purpose of private study or research.
- ? You may not further distribute the material or use it for any profit-making activity or commercial gain
- ? You may freely distribute the URL identifying the publication in the public portal ?

### **Take down policy**

If you believe that this document breaches copyright please contact us at [vbn@aub.aau.dk](mailto:vbn@aub.aau.dk) providing details, and we will remove access to the work immediately and investigate your claim.

## Experience with the Notch Stress Approach for Fatigue Assessment of Welded Joints

M.M. Pedersen<sup>1,3</sup>, O.Ø. Mouritsen<sup>1</sup>, M.R. Hansen<sup>2</sup>, J.G. Andersen<sup>3</sup>

<sup>1</sup> Aalborg University, Dept. of Mechanical Engineering, DK-9220, Denmark

<sup>2</sup> University of Agder, Dept. of Engineering, NO-4876, Norway

<sup>3</sup> HMF A/S, DK-8270, Denmark

[mmp@hmf.dk](mailto:mmp@hmf.dk)

### Abstract

In this paper, fatigue assessment using the notch stress approach is discussed based on re-analysis of many fatigue test results and experience from practical application. Three topics are treated; evaluation of the fatigue strength for as-welded details (FAT225) in the notch stress system, problems regarding assessment of mild-SCF details and a novel proposal for extension of the notch stress approach for use with post-weld treated details.

### Introduction

The notch stress approach has received much attention lately due to the increasing available computational power and the need for assessing more increasingly complex geometries. The approach is very flexible in the sense that both the toe and the root of all types of welded joints can be assessed using a single S-N curve.

Radaj *et al.* [1] presents a thorough review of the history of the approach. Fricke [2] gives practical guidelines for the notch modelling and stress analysis and Sonsino [3] proposes S-N curves to be used under different conditions. The approach is included in the IIW fatigue design recommendations by Hobbacher [4].

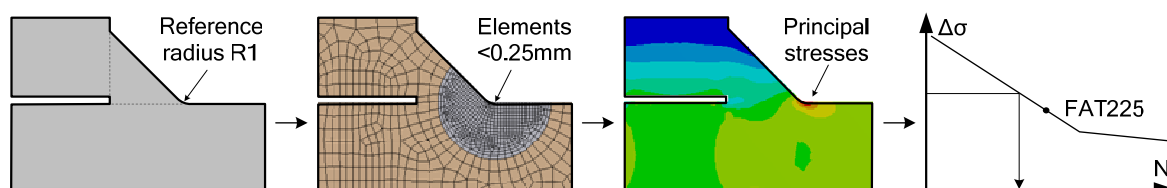

Fig. 1: Schematic principles of fatigue assessment using the notch stress approach.

The notch stress approach correlates the stress range in a fictitious rounding in the weld toe or root to the fatigue life using a single S-N curve. The notch stress is typically obtained using finite element models with the reference radius of 1mm in order to avoid the stress singularities in sharp notches. The approach is schematically illustrated in Fig. 1. In this paper, notch stresses are calculated using the first principal stress (denoted by index PS in diagrams).

The approach is based on the work by Radaj [5] and modified by Seeger and co-workers, see Olivier *et al.* [6,7]. Here, the reference radius of R1 is determined as a mean value and the design fatigue strength (FAT225) is derived from experiments.

### Fatigue strength in the notch stress system

The IIW recommends the use of FAT225 when considering the fatigue strength of welded steel joints using the notch stress approach. This value was derived based on the results of a large experimental investigation of different T- and Y-joints [6,7] and further re-analysis of the results assembled by Olivier & Ritter [8]. Kranz & Sonsino [9] explain the assumptions that led to the derivation of the FAT225 fatigue class.

Pedersen *et al.* [10] carried out a re-analysis using the notch stress approach, and found the FAT225 to be slightly non-conservative, as shown in Fig. 2. The re-analysis was carried out to evaluate the notch stress approach according to the IIW and provide further experimental evidence to the approach.

The fatigue data was extracted from recent publications and converted to the notch stress system by scaling the nominal stress range with the stress concentration factor determined by FE analysis. Only tests carried out in the as-welded condition and under positive stress ratio ( $R \geq 0$ ) were considered. The steel grade varied from S235-S1100 and the thickness was 5-25mm.

Four different specimen types were considered; T-joints, double-sided transversal attachments, butt joints and double-sided longitudinal stiffeners. The T-joints are assessed very conservatively because they are tested in bending. In the nominal stress system, the fatigue data agree quite well with the FAT classes suggested by the IIW [4], therefore, the quality of the specimens is considered to be representative of normal quality.

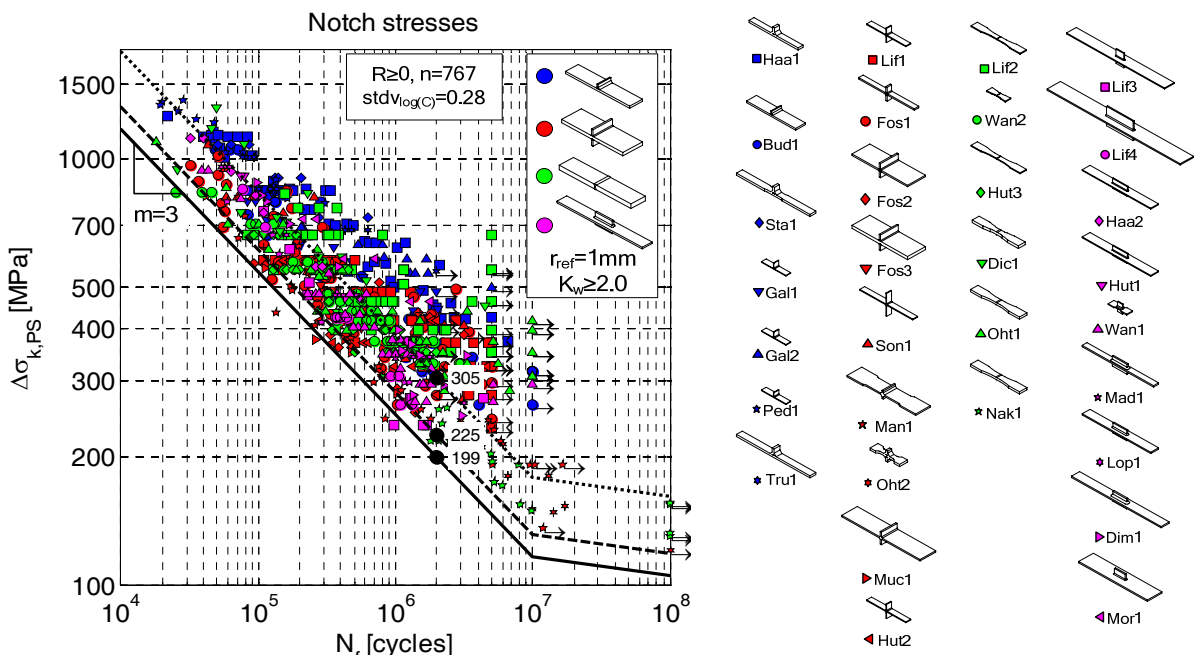

**Fig. 2: FAT225 seems to be too optimistic and the reduced FAT200 is therefore proposed in order to achieve approximately the same safety as in the nominal stress system [10].**

If excluding run-outs and using a slope of  $m=3.0$ , the mean fatigue strength ( $P_S=50\%$ ) is FAT305. The standard deviation of  $\log(C)$  is 0.28, and thus the design curve can be calculated ( $P_S=97.7\%$ ) to FAT199 (mean - 2 standard deviations). It was therefore suggested to reduce the fatigue strength from FAT225 to FAT200 to achieve approximately the same safety as observed in the nominal stress system.

### Mild SCF joints

It is well known that the notch stress approach can lead to non-conservative assessment of mild SCF joints, e.g. thin butt joints, thus there is a need for further insight into the problem. The subject is discussed in terms of thin butt joints and a mild SCF crane detail.

### Butt Joints

For butt joints, the IIW suggests the idealized geometry shown in Fig. 3 for notch stress analysis. The problem with this geometry is that the resulting SCF will be very, low especially for thin joints, e.g.  $K_t \sim 1.6$  for 8mm thickness.

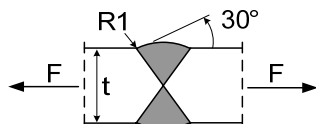

Fig. 3: Idealized geometry for notch stress assessment of butt joints.

In Fig. 4 fatigue test data for many butt joints are compared in the nominal (left) and notch stress system (right). The fatigue data is converted using the formula  $K_t(t) = 1.055 \cdot t^{0.216}$  derived in [10] and  $k_m = 1.10$  to consider a stress increase due to misalignment, as suggested by Hobbacher [4].

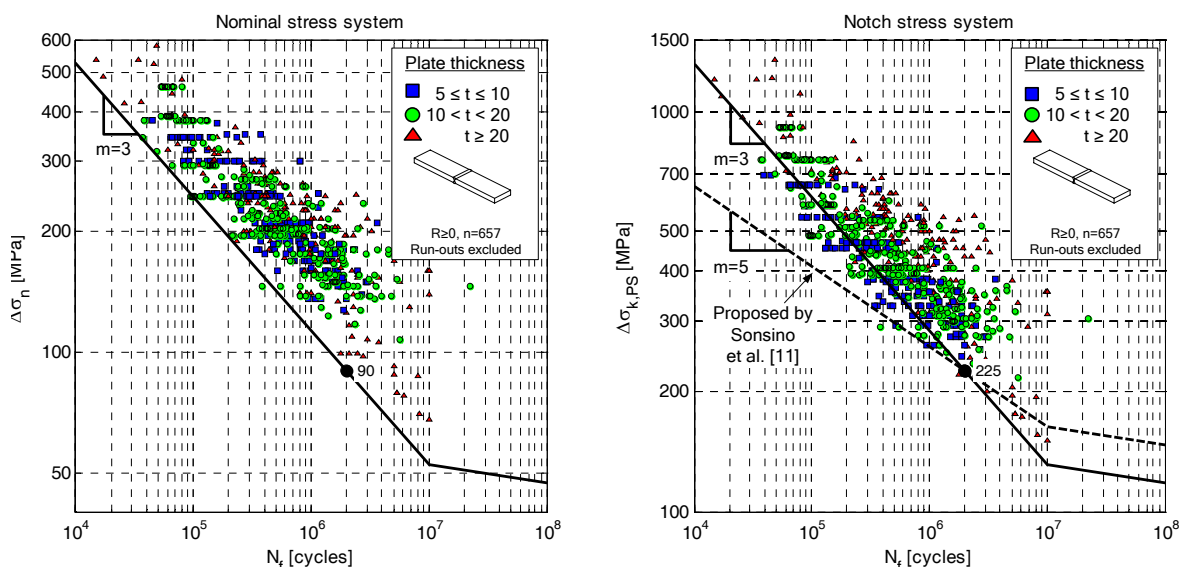

Fig. 4: Thin butt joints can be assessed non-conservatively by the notch stress approach [10].

It is seen that the fatigue strength of all butt joints are approximately identical in the nominal stress system, regardless of the different specimen thickness. In the notch stress system, however, many thin joints are assessed non-conservatively because of the very low SCF determined for these joints. A remedial action was therefore suggested, i.e. requiring a minimum notch factor of  $K_w \geq 2.0$ , instead of the current  $K_w \geq 1.6$  given by the IIW [2].

Sonsino *et al.* [11] also reports problems with fatigue assessment using the notch stress approach considering thin/flexible welded joints, e.g. butt joints. They observed shallower slopes for these particular joints and therefore suggest the use of a shallower slope,  $m=5.0$ , while maintaining the FAT225 value. As it is seen in Fig. 4 (right), this approach seems promising in the high cycle area, but too conservative in the medium-to-low cycle area.

### Crane Detail

Another type of mild SCF joint where the notch stress approach can lead to non-conservative results is the crane detail shown in Fig. 5. The fatigue critical location is the weld toe in front of the termination of the weld seam around the reinforcement plate. This type of reinforcement is often used in high strength steel structures, where a concentrated load is distributed into the main plate, e.g. in a revolutive joint, since the bearing load will otherwise be too high. There are many examples of complicated geometries used in order to 1) reduce the stress concentration factor by softening/tapering out the reinforcement and 2) move the fatigue critical location to an area with reduced loading, e.g. near the centreline of beams.

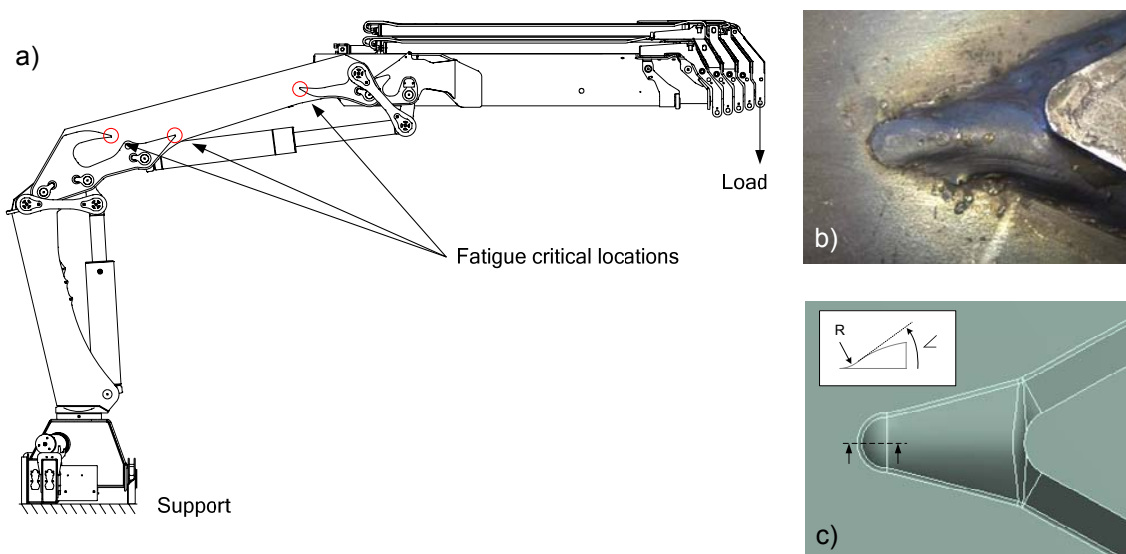

Fig. 5: a) Crane with reinforcement detail, b) actual weld, c) idealized weld.

Rasmussen [12] investigated the considered detail experimentally and numerically, Tab. 1 and Fig. 6. This detail is a good example of a weld, where the geometry of the weld itself has a significant influence on the fatigue strength and therefore has to be taken into account, e.g. by using the notch stress approach.

The welded specimens were manufactured by the Danish crane manufacturer HMF A/S using 5mm thick S700 and normal quality MAG welding. Fatigue testing were carried out at Aalborg University at a stress ratio of  $R=0.1$  and with special attention to the medium cycle area.

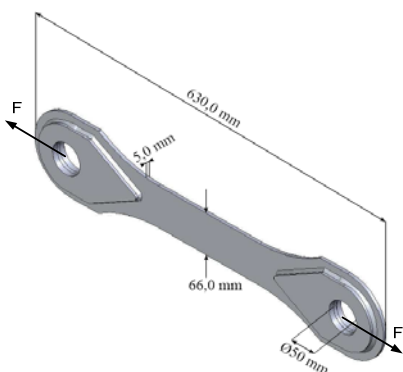
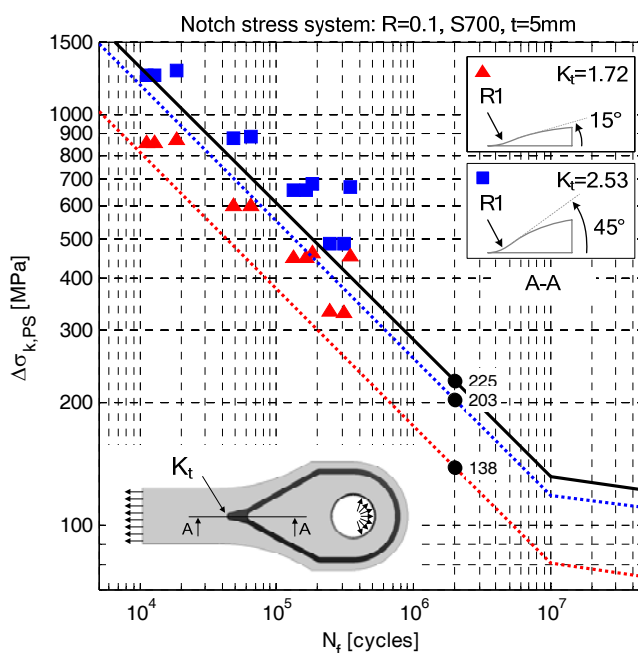

Fig. 6: Specimen geometry [12].

$\Delta F$ [kN]	$\Delta\sigma_n$ [MPa]	$N_f$ [cycles]
168	509	18.414
168	509	12.966
88	267	183.228
86	261	131.935
115	348	48.740
63	191	306.932
164	497	12.805
164	497	11.148
87	264	346.114
115	348	64.980
64	194	242.445

For such at detail, the question arises, how to idealize the local weld geometry? Assuming a reference radius of R1 seems logic, but what about the remainder of the weld, especially the flank angle?

The results are presented in Fig. 7 in the notch stress system using two different modelling techniques – real flank angle (15°) and assumed flank angle (45°). Using the real flank (15°), the SCF is determined to  $K_t=1.72$  and using the assumed 45° flank angle, the SCF is  $K_t=2.53$ . It is clear from Fig. 7, that the results fit the FAT225 curve best, if the assumed 45° flank angle is applied. It is however a quick-and-dirty solution for achieving conservative results using the notch stress approach for this particular detail.



**Fig. 7: Fatigue testing results for crane detail, incl. design curves ( $P_S=97.7\%$ ) for two different modelling techniques compared with the FAT225 curve.**

The example shows how important the idealization of the weld geometry is to the final result of the fatigue assessment using the notch approach. It is clear, that experience with the approach is needed, and it is highly recommended to compare results with other (local) approaches.

### Extension to post weld treatment

Using the notch stress approach for fatigue assessment of post weld treated details is a subject still under debate. The IIW recommendations by Fricke [2] suggest using a model of the real toe radius + 1mm and evaluate the principal stress range here against the FAT200 SN curve. However, it is also stated, that this approach is only valid for relatively sharp notches, i.e. with a toe radius of R1-3mm, and that the approach has not been verified.

Fig. 8 shows examples of increased weld toe radii due to different post weld treatments. Typically, when performing post weld treatment, a large toe radius is desired and e.g. grinding and TIG dressing will generally leave a radius larger than R3.

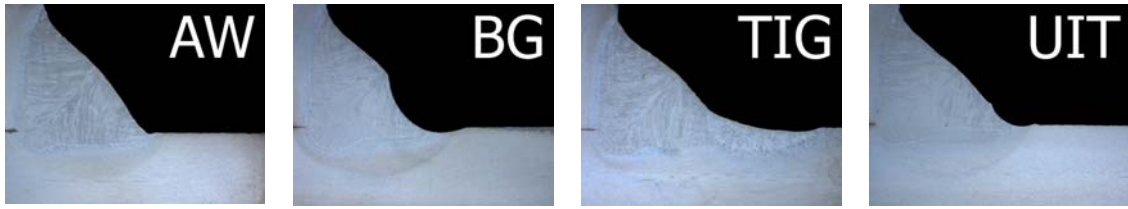

Fig. 8: Typical toe profiles for post-weld treated welds compared to as welded condition [23].

Fig. 9 shows the results of measurements of weld toe profiles published in the literature. It is clear, that the toe radius will vary a lot in production and will be difficult to estimate in a design situation. The question therefore arises, which "real" radius to use – the mean, or some lower value? Since the value of the toe radius typically follows a Gaussian distribution, the minimum value is not well defined.

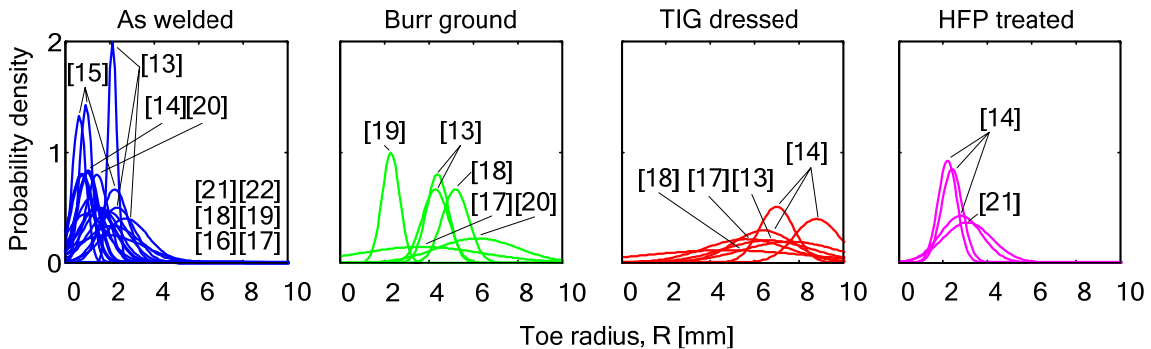

Fig. 9: Measurements of toe radius for as welded and post weld treated welds toes [13-22].

For welds in the as-welded condition, the average toe radius is approximately R1-R1.5, depending on the quality level. For burr ground welds, the average is in the order of R4, depending on the chosen burr and the skill of the operator. The radius of TIG dressed welds varies the most – from R0 to R12+. This radius depends heavily on the skill of the operator and position of the weld relative to gravity. The average is approximately R6. Welds treated by high frequency peening (HFP) also achieves varying radii, but not as random as TIG – here the average is around R2.5.

Conclusively, if the approach suggested by IIW [2], should be applied with the average radius, it will only be applicable for HFP post weld treatment, since BG and TIG typically results in radii larger than R3.

Weich [24] recently proposed an approach for assessing HFP treated welded joints using the notch stress approach. The idea is to consider an effective stress ratio and hereby apply an improvement factor of up to  $f(R'_{eff})=1.6$  for effective stress ratios of  $R'_{eff} < -1$ . The effective stress ratio is based on a superposition of the local stresses and compressive residual stresses introduced by the treatment. This approach is presumably quite accurate, but difficult to apply in a design situation, because the level of compressive residual stresses introduced by the treatment will be unknown.

### A New Approach

An alternative procedure for assessing post weld treated joints using the notch stress approach is investigated in the following. The basic idea is to maintain the reference radius at R1 and use a higher FAT class for fatigue assessment of post weld treated joints. This is chosen such that an engineer can easily assess whether post weld

treatment is necessary and sufficient, using the same FE model as used for assessing the joint in as-welded state. This approach seems very practical, but also has the obvious drawback, that the computed notch stress becomes even more of a model-number, than in the as-welded case, because the model geometry differs more from the actual geometry.

The higher FAT classes are derived based on a large collection of experimental results for post weld treated details. Only burr grinding, TIG dressing and high frequency peening (HFP), e.g. UIT, are considered and only fillet welded joints. Post weld treated butt joints are considered unsuitable for assessment using the notch stress approach, since the notch stress concentration may be completely removed, as in the case of disc grinding.

Most test results considered are for high strength steel, S355-S1100, except some in the series denoted Hut2, Kud1 and Wan1 which also considers mild steel. Only fatigue tests carried out under positive stress ratios are considered and only publications with thorough description of the specimen geometry.

By considering the fatigue data for post weld treatment in the notch stress system, the difference in the geometry of the test specimens can be disregarded to some extent. At least the effect of different stress concentration factors of the specimens can be disregarded. However, some specimens can contain higher levels of tensile residual stresses than others and this effect cannot be disregarded. Still, suggestions for design curves can be given based on a larger volume of fatigue data than usual.

Traditional statistical treatment of the experimental results yields poor results because of very large scatter in the data. This is due to different testing conditions, quality of the post weld treatment, thickness etc. The suggested FAT classes are therefore not directly calculated but simply given based on practical estimation.

T-joints					Transversal attachments					Longitudinal attachments				
ID	Ref	S <sub>y</sub> MPa	t [mm]	K <sub>t</sub> -	ID	Ref	S <sub>y</sub> MPa	t [mm]	K <sub>t</sub> -	ID	Ref	S <sub>y</sub> MPa	t mm	K <sub>t</sub> -
Haa1	[25]	420	20	2.80	Lif1	[30]	700-1100	8	2.35	Lif3	[30]	690-1100	8	3.42
Bud1	[26]	550-690	16	2.64	Fos1	[14]	355-690	12	2.49	Lif4	[30]	690-1100	8	3.85
Sta1	[27]	420	20	2.91	Fos2	[14]	355-690	12	2.57	Haa2	[34]	355-700	8	3.73
Gal1	[28]	700	5	1.99	Fos3	[14]	690	25	2.69	Hut1	[18]	700	8	3.73
Gal2	[28]	355	6	2.03	Son1	[31]	1100	8	2.20	Wan1	[35]	235-700	8	2.69
Ped1	[23]	700	6	2.03	Man1	[32]	355-700	12.5	2.72	Wei2	[36]	690	16	2.40
Tru1	[29]	420	20	2.73	Hut2	[19]	235-355	8	2.32	Mad1	[37]	355	13	3.32
					Kud1	[33]	260	20	3.10	Lop1	[38]	355-590	12	3.82
										Dah1	[39]	355-590	12	3.82
										Mor1	[20]	417	12	4.01

Tab. 2: Extracted experimental fatigue data series. K<sub>t</sub> is determined according to [2].

### Burr Grinding & TIG Dressing

Grinding reduces the stress concentration factor of welded joints and removes included defects in the ground area. The experimental data suggests parallel shifting of the S-N curve upwards and FAT300 is suggested, as shown in Fig. 10. This corresponds to an increase of approximately a factor of 1.3 on the fatigue strength. This is the same factor as suggested by the IIW [40] for mild steel joints in the nominal stress system.



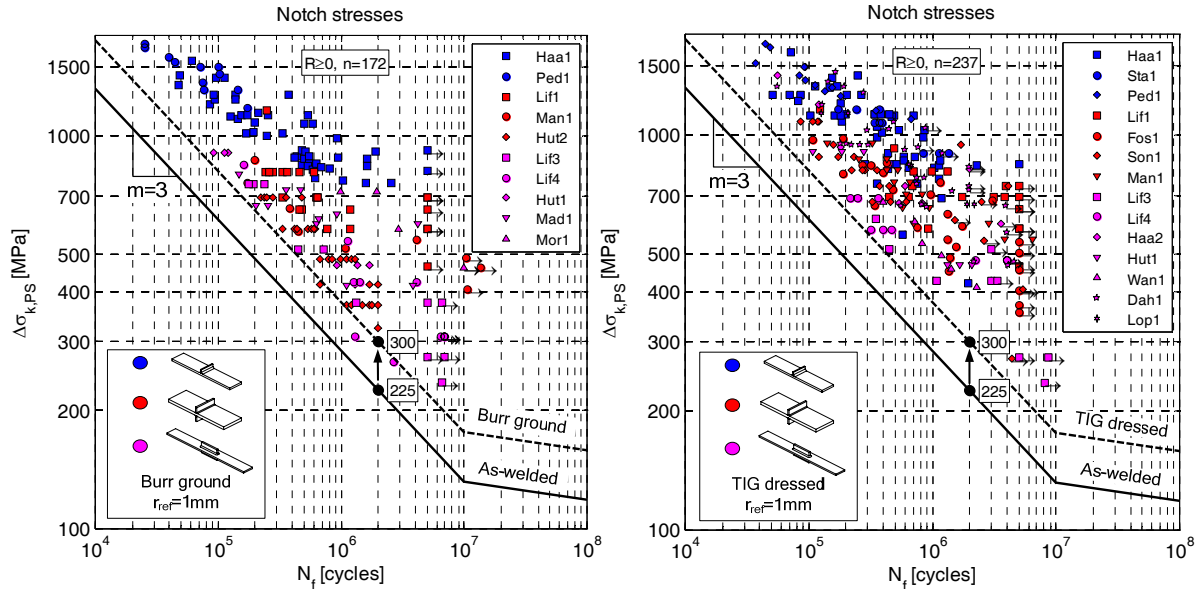

**Fig. 10: Fatigue data for burr grinding (left) and TIG dressing (right) compared to the as-welded design curve in the notch stress system.**

TIG dressing improves the welded joint in much the same way as grinding, i.e. the stress concentration is reduced and defects are removed. The experimental data also supports the use of the same S-N curve for both ground and TIG dressed welded joints, i.e. FAT300.

### High Frequency Peening (HFP) Treatment

The following different types of high frequency peening treatments are described in the literature; ultrasonic impact treatment (UIT) [14], ultrasonic peening (UP) [29], high frequency impact treatment (HiFIT) [36] and ultrasonic needle peening (UNP) [41]. UIT is based on magnetostriction, UP uses a piezoelectric transducer, whereas HiFIT is pneumatically actuated.

Although they are different processes, their properties and resulting improvement in fatigue strength appear to be similar. Here, the treatments are considered equal and denoted HFP treatments.

The HFP treatments improve the fatigue strength of the welded joint in several ways by plastic deformation of the weld toe. Firstly, the tensile residual stress state present in the weld seam is relieved and beneficial compressive residual stresses are introduced. Secondly, the sharp notch in the weld toe is blunted and the treatment leaves behind a smooth trace with a radius of 2-3mm, see Fig. 8. Finally, the surface material is mechanically hardened, which locally increases the fatigue strength of the material in the notch [42].

Since peening treatments improve the fatigue strength of welded joints primarily based on the introduction of compressive residual stresses, a flatter S-N curve is expected. As evident from Fig. 11, a rotated S-N curve using FAT360 with the slope of  $m=5.0$ , fits the experimental data well.

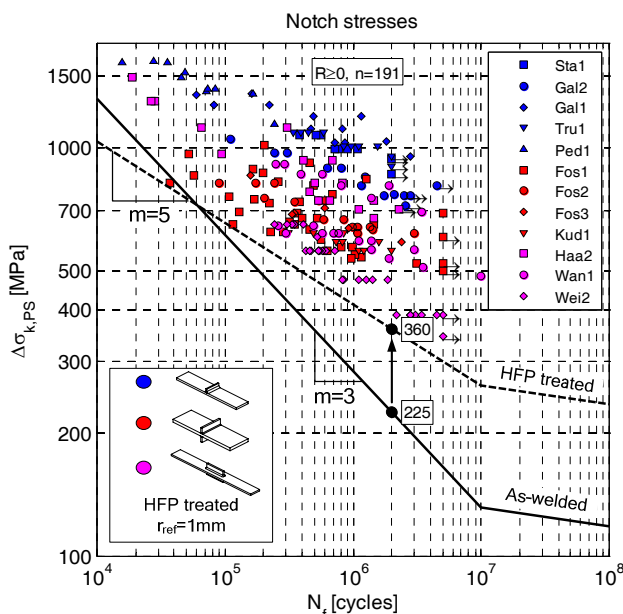

**Fig. 11: Fatigue data for HFP treatment compared to the as-welded design curves in the notch stress system.**

Due to the flatter slope, the HFP design curve is lower than the as-welded design curve for  $N < 50.000$ . However, it is clear that the lack of further experimental data, especially in the low cycle area, limits the reliability of the suggested design curve here. It is not likely, that the HFP treatment decreases the fatigue strength in the low cycle area; therefore, the as-welded design curve could be applied here.

## Conclusions

The following conclusions are drawn based on re-analysis of fatigue data and practical experience with the notch stress approach.

- For fatigue assessment using the notch stress approach, it is proposed to reduce the fatigue strength to FAT200 for as-welded normal quality, based on a large amount of experimental data.
- For mild SCF joints, it is suggested to use a minimum notch factor of  $K_w \geq 2.0$  instead of the current  $K_w \geq 1.6$ . Alternatively, conservative results can be achieved by modelling the flank angle steeper than the real flank angle.
- For fatigue assessment of post-weld treated details, an approach is suggested where the stress analysis is carried out identically to as-welded details, i.e. the reference radius of R1 is maintained, but the FAT class is increased.
  - For both burr ground and TIG dressed details, a FAT class of FAT300 using  $m=3.0$  is suggested.
  - For HFP treated details, e.g. UIT, FAT360 is suggested with a flatter slope of  $m=5.0$ .

## Acknowledgements

The research work is funded by HMF A/S and an industrial PhD-grant from the Danish Ministry for Science, Technology and Innovation.

## References

1. Radaj D., Sonsino C.M., Fricke W., "Fatigue Assessment of Welded Joints by Local Approaches", 2<sup>nd</sup> ed., Woodhead Publishing Ltd., Cambridge, 2006.
2. Fricke W., "Guideline for Fatigue Assessment by Notch Stress Analysis for Welded Structures", IIW Doc. XIII-2240r1-08/XV-1289r1-08, 2008.
3. Sonsino C.M., "Suggested Allowable Equivalent Stresses for Fatigue Design of Welded Joints According to the Notch Stress Concept with the Reference Radii  $r_{ref}=1.00$  and  $0.05\text{mm}$ ", IIW Doc. XIII-2216-08/XV1285-08, 2008.
4. Hobbacher A., "Recommendations for Fatigue Design of Welded Joints and Components", IIW Doc. IIW-1823-07, 2008.
5. Radaj D., "Design and Analysis of Fatigue Resistant Welded Structures", Woodhead Publishing Ltd., Cambridge, 1990.
6. Olivier R., Köttgen V.B., Seeger T., "Schweissverbindung I", FKM Forschungshefte 143, Frankfurt/M, 1989.
7. Olivier R., Köttgen V.B., Seeger T., "Schweissverbindung II", FKM Forschungshefte 180, Frankfurt/M, 1994.
8. Olivier R., Ritter W., "Wöhlerlinienkatalog für Schweissverbindungen aus Baustählen", DVS GmbH, Düsseldorf, 1979.
9. Kranz B., Sonsino C.M., "Verification of the Notch Stress Concept for the Reference Radii of  $R_{ref} = 1.00$  and  $0.05\text{mm}$ ", IIW Doc. XIII-2274-09, 2009.
10. Pedersen M.M., Mouritsen O.Ø., Hansen M.R., Andersen J.G., Wenderby J., "Re-analysis of Fatigue Data for Welded Joints Using the Notch Stress Approach", accepted for publication in International Journal of Fatigue, 2010.
11. Sonsino C.M., Bruder T., Baumgartner J., "SN-curves for Welded Thin Joints – Suggested Slopes and FAT-values for Applying the Notch Stress Concept with Various Reference Radii", IIW-Doc. XIII-2280-09, 2009.
12. Rasmussen L.V., "Levetidsbestemmelse og analyse af typisk svejst krandedetalje i højstyrkestål" (Danish), M.Sc. thesis, Inst. of Mechanical Engineering, Aalborg University, 2008.
13. Lieurade H.P., Huther I., Lefebvre F., "Effect of Weld Quality and Post Weld Improvement Techniques on the Fatigue Resistance of Extra High Strength Steels", IIW Doc. XIII-2184-07, 2007.
14. Kuhlmann U., Dürr A., Bergmann J., Thumser R., "Effizienter Stahlbau aus höherfesten Stählen unter Ermüdungsbeanspruchung", Forschungsvorhaben P620, FOSTA, Verlag und Vertriebsgesellschaft GmbH, Düsseldorf, 2006.
15. Jonsson B.J., Barsoum Z., Ghavi Bazou A., "Influence From Weld Position on Fillet Weld Quality", IIW Doc. XIII-2273-09, 2009.
16. Barsoum Z., "Residual Stress Analysis and Fatigue Assessment of Welded Steel Structures", Ph.D. Thesis, KTH, Stockholm, 2008.
17. Moura Branco C., Gomes E.C., "Development of Fatigue Design Curves for Weld Improved Joints", Fatigue Design 1995. Proceedings VTT Symposium 157, Helsinki, 5-8th Sept. 1995.
18. Huther I., Suchier Y., Lieurade H.P., "Fatigue Behaviour of Longitudinal Non-load Carrying Joints Improved by Burr Grinding, TIG dressing", IIW Doc. XIII-2108-06, 2006.
19. Huther I., Minard V., Royer Y., Lieurade H.P., "Burr Grinding Effect on the Fatigue Strength as Regard to Initial Weld Quality", IIW Doc. XIII-2038-04, 2004.
20. Mori T., Inomata T., "Influence of Grinding Method on Fatigue Strength of Out-of-Plane Gusset Welded Joints", IIW Doc XIII-1970-03, 2003.
21. Tominaga T., Matsuoka K., Sato Y., Suzuki T., "Fatigue Improvement of Weld Repaired Crane Runway Girder by Ultrasonic Impact Treatment", IIW Doc. XIII-2170-07, 2007.
22. Lee C-H., Chang K-H., Jang G-C, C-Y. Lee, "Effect of Weld Geometry on the Fatigue Life of Non-load-Carrying Fillet Welded Cruciform Joint", Engineering Failure Analysis, 16, pp.849-855, 2009.

23. Pedersen M.M., Mouritsen O.Ø., Hansen M.R., Andersen J.G., Wenderby J., "Comparison of Post Weld Treatment of High Strength Steel Welded Joints in Medium Cycle Fatigue", IIW Doc. XIII-2272-09, 2009.
24. Weich I., "Edge Layer Condition and Fatigue Strength of Welds Improved by Mechanical Post Weld Treatment", IIW Doc. XIII-2265-09, 2009.
25. Haagensen P.J., "IIW's Round Robin and Design Recommendations for Improvement Methods", Proc. IIW 50th Annual Assembly Conference, San Francisco, Welding Research Council Inc., New York, 1997.
26. Budano S., Kupperts M., Kaufmann H., Meisozo A.M., Davis C., "Application of High Strength Steel Plates to Welded Deck Components for Ships and Bridges Subjected to Medium/High Service Loads", EUR22571EN, European Commission, Brussels, 2007.
27. Statnikov E.S., Muktepavel V.O., Blomqvist A., "Comparison of Ultrasonic Impact Treatment (UIT) and Other Fatigue Life Improvement Methods", *Welding in the World* 46, pp.28-39, 2002.
28. Galtier A., Statnikov E.S., "The Influence of Ultrasonic Impact Treatment on Fatigue Behaviour of Welded Joints in High-Strength Steel", *Welding in the World*, 48 (5/6), 2004.
29. Trufiakov V.I., Statnikov E.S., Mikheev P.P., Kuzmenko A.Z., "The Efficiency of Ultrasonic Impact Treatment for Improving the Fatigue Strength", IIW Doc. XIII-1745-98, 1998.
30. Lagerqvist O., Clarin M., Gozzi J., Völling B., Pak D., Stötzl J., Lieurade H.P., Depale B., Huther I., Herion S., Bergers J., Martsch R.M., Carlsson M., Samuelsson A., Sonander C., "LiftHigh – Efficient Lifting Equipment with Extra High-Strength Steel", European Commission, EUR22569EN, Brussels, 2007.
31. Sonander C., "Ermüdung von geschweissten Kreuzstößen aus Weldox 1100", *Stahlbau*, 69 (4), 2000.
32. Manteghi S., Maddox S.J., "Methods for Fatigue Life Improvement of Welded Joints in Medium and High Strength Steels", IIW-Doc. XIII-2006-04, 2004.
33. Kudryavtsev Y., Kleiman J., Lugovskoy A., Lobanov L., Knysh V., Voitenko O., Prokopenko G., "Rehabilitation and Repair of Welded Elements and Structures by Ultrasonic Peening", *Welding in the World*, 51 (7/8), 2007.
34. Haagensen P.J., Alnes Ø., "Progress Report on IIW WG2 Round Robin Fatigue Testing Program on 700MPa and 350MPa YS Steels", IIW Doc. XIII-2081-05, 2005.
35. Wang T., Wang D., Huo L., Zhang Y., "Discussion on Fatigue Design of Welded Joints Enhanced by Ultrasonic Peening Treatment (UPT)", *International Journal of Fatigue*, 31, pp. 644-650, 2009.
36. Weich I., "Ermüdungsverhalten mechanisch nachbehandelter Schweißverbindungen in Abhängigkeit des Randschichtzustands", Ph.D. Thesis, Technischen Universität Braunschweig, 2008.
37. Maddox S.J., "Improving the Fatigue Strength of Toe Ground Welds at the End of Longitudinal Stiffeners", IIW-Doc. XIII-2156-07, 2007.
38. Lopez Martinez L., Blom A., "Influence of Life Improvement Methods on Different Steel Grades under Fatigue Loading", *Fatigue Design 1995. Proc. VTT Symposium 157*, Helsinki, 5-8. Sept., 1995.
39. Dahle T., "Design Fatigue Strength of TIG-dressed Welded Joints in High-Strength Steels Subjected to Spectrum Loading", ABB Corporate Research, S-721, 78, Sweden, 1998.
40. Haagensen P.J., Maddox S.J., "IIW Recommendations on Post Weld Improvement of Steel and Aluminium Structures", IIW Doc. XIII-2200-07, 2007.
41. Bousseau M. & Millot T., "Fatigue Life Improvement of Welded Structures by Ultrasonic Needle Peening Compared to TIG Dressing", IIW-Doc. XIII-2125-06, 2006.
42. Ummenhofer T., Weich I., "Fatigue Design Concepts for Welds Improved by High Frequency Hammer Peening Methods", *Proceedings of the Fatigue Design 2007 conference, CETIM 21-23. November, 2007.*