



International Symposium on "Novel Structural Skins: Improving sustainability and efficiency through new structural textile materials and designs"

Cable Erection of Krasnodar Stadium Suspended Roof

Daniela Lombardini^{a*}, Silvia Geyer^a

^aRedaelli Tecna, Via Alessandro Volta 16, Cologno Monzese 20093, Italy

Abstract

The Krasnodar Stadium, hosting FC Krasnodar of Russian Premier League, has a capacity of 36.260 seats. The stadium roof is designed as a typical looped cable roof containing two compression rings and one tension ring. The roof is covered by a folded membrane, the inner perimeter towards the pitch is built as a 7m wide glass roof to improve the natural lighting of the pitch. The radial cables run along 56 axes from compression to tension rings. All cables forming the tension ring are connected by couplers, thus creating round cables. Redaelli took part in the project providing the supply, installation and big lift of 416 steel ropes, for a total mass of 500 tons including sockets and cast ring connectors.

© 2016 Published by Elsevier Ltd. This is an open access article under the CC BY-NC-ND license

(<http://creativecommons.org/licenses/by-nc-nd/4.0/>).

Peer-review under responsibility of the TensiNet Association and the Cost Action TU1303, Vrije Universiteit Brussel

Keywords:

1. Introduction

This paper describes Redaelli contribution to the construction of the Krasnodar Stadium roof. The cable supported membrane structure of the roof is based on the spoke wheel principle, with two steel box compression rings and one cables tension ring. The lower compression ring is placed on top of the inner wall of the arcade, the upper compression ring is sustained by outer columns. Radial cables span in between circumferential steel structures at the two levels and they are connected by hanger cables, thus forming radial cable trusses.

* Corresponding author.

E-mail address: daniela.lombardini@redaelli.com

The roof cladding is a double layer membrane. The top layer is folded on cables trusses, alternating between upper and lower radial cables and forming a peak at the outer hanger. Towards the pitch there is a 7 m wide glass roof made of panels sustained by cantilever beams, which are resting on the tension ring and are supported by the first hangers of cable trusses.

2. Redaelli supply

Redaelli supplied the entire cable system for the Krasnodar Stadium Roof, including clamps and connectors. The following table summarizes the entire supply, in terms of cable type, diameter, number of elements and socket types.

Table 1. Summary of Redaelli Supply.

Item	Cable Type	Diameter (mm)	Element number	Socket 1	Socket 2
Tension Ring	FLC	95	16	CYC	CYC
Upper Radial Cables	FLC	70 to 115	56	TTF	TTF
Lower Radial Cables	FLC	55 to 75	56	TTF	TTF
Bracings	FLC	55	64	TTF	TBF
Diagonal	OSS	31	56	TTF	TTF
Hanger Cables	OSS	17	168	MCC	MCC
Ring Cables Connectors	-	-	56	-	-
Hanger Clamps	-	-	308	-	-
Roof Cap Clamp	-	-	2	-	-

All Redaelli cables are made by hot-dip galvanized high strength steel round wires, spun in opposite directions around a central core. Open spiral strands (OSS) cables are made up of several layers of round wires, Full lock coil cables (FLC) have external layers of Z-shaped wires which provide self-locking of the cable section.

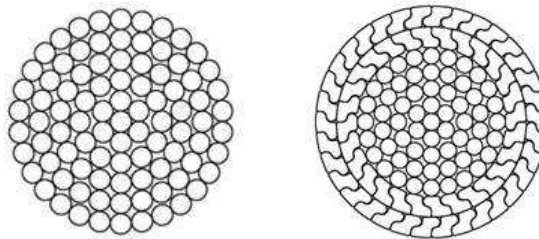

Fig. 2. Open Spiral Strand Cables (left) and Full Lock Coil Cables (right).

In order to eliminate initial anelastic strains, cables were prestretched with minimum five cycles. The desired cable cutting lengths and intermediate clamp positions were precisely marked under specific loads and controlled temperature, a total of 56 marking positions on each ring cable and 3 marking positions on each radial cable was executed.

Fork sockets and connectors were made of high strength cast steel, whereas the cylindrical sockets, turnbuckles, pins and clamps were produced using machined high strength alloy steel. Sockets and ring cable connectors were painted, on top of the corrosion protection zinc layer, in grey color. Krasnodar Roof cables were connected to the sockets with Polyester resin, with the only exception of hanger cables which were fixed to the sockets by swaging, ensuring nevertheless a breaking force of the final cable system not lower than 0,9 times the breaking force of the initial cable.

Hereafter some pictures illustrate the main items of Redaelli's supply.

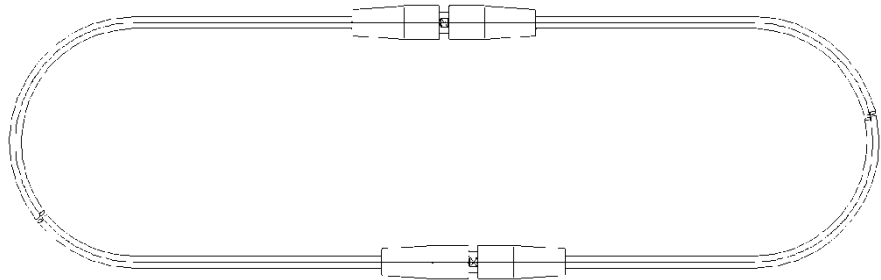

Fig. 3. Full Lock Coil Cable (FLC) with CYC Coupler Cylindrical Sockets (Tension Ring Cables).

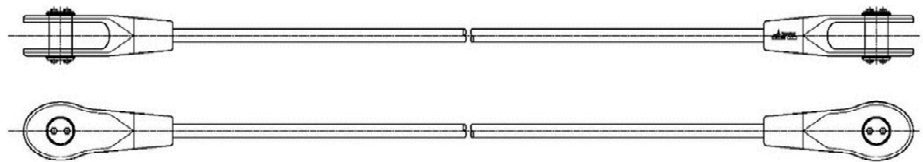

Fig. 4. Full Lock Coil Cable (FLC) with TTF/TTF Sockets (Radial and Diagonal Cables).

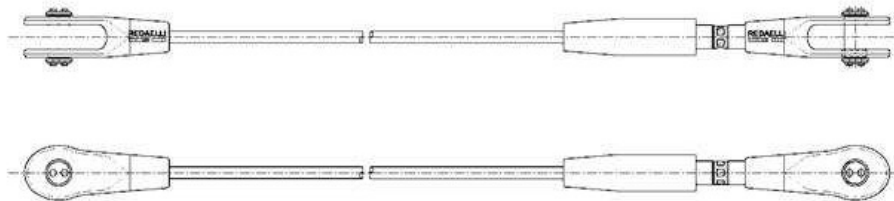

Fig. 5. Full Lock Coil Cable (FLC) with TTF/TBF Sockets (Bracings).

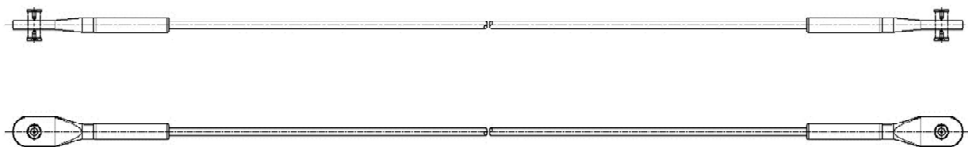

Fig. 6. Open Spiral Strand Cable (OSS) with MCC Swaged Sockets (Hanger Cables).

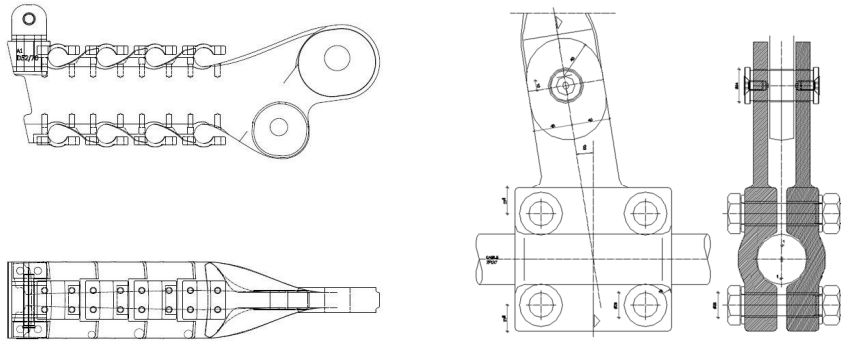

Fig. 7. Ring Cables Connector (left) and Hanger Clamp (right).

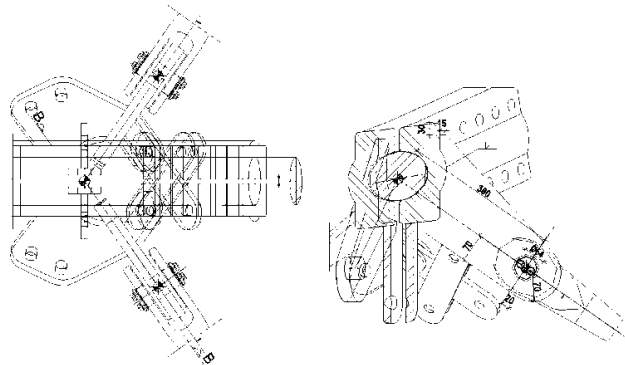

Fig. 8. Roof Cap Clamp.

The overall quality of the supply was assured by a wide campaign of tests on every component. In addition to destructive and not destructive controls on castings and forged sockets, full scale tensile tests were executed on one cable sample for each size, the samples were fitted with sockets equal to permanent ones. Furthermore, 200-hour long term tests helped to verify the creep on the cables, as well as slipping force tests were used to establish the sliding force of hanger cable clamps and ring cable connectors. Control activities were carefully inspected and examined, also by means of external supervisors, and each step of the production process was accurately tracked and overseen.

3. Site activities

All activities related to cables installation and tensioning were agreed with the Main Contractor so that Redaelli presence on site was organized and synchronized with other site works. Cable installation and tensioning followed the procedure defined by the Designer (SBP GMBH). Site activities performed by Redaelli are grouped and described in the following paragraphs.

3.1. Site preparation and lay down of the cables

Site preparation was carefully planned taking into account necessary storage areas for such a large supply and required assembly areas at proper location according to the site activities schedule.

All cables were supplied in coils and were unwound using uncoilers with the required capacity.



Fig. 9. Redaelli Cable on the uncoiler.

The first step of cable installation was to uncoil every cable and to lay it down. Cables were uncoiled lifting the top socket with a crane and placing each cable lying at the corresponding position, so that cable system layout was generated on the ground level. For each axis of radial cables, reinforced wooden strips were previously placed on stadium stands and wooden saddles were provided to let the cable sliding over the parapet.



Fig. 10. Site Preparation with Reinforced wooden strips.

Similarly, timber platforms were built at the location of ring connector castings to protect their surface and the concrete below. The exact position of each timber platform was calculated theoretically according to the cable system layout. These platforms had an internal opening to allow for the sliding of ring connectors during tensioning operations.

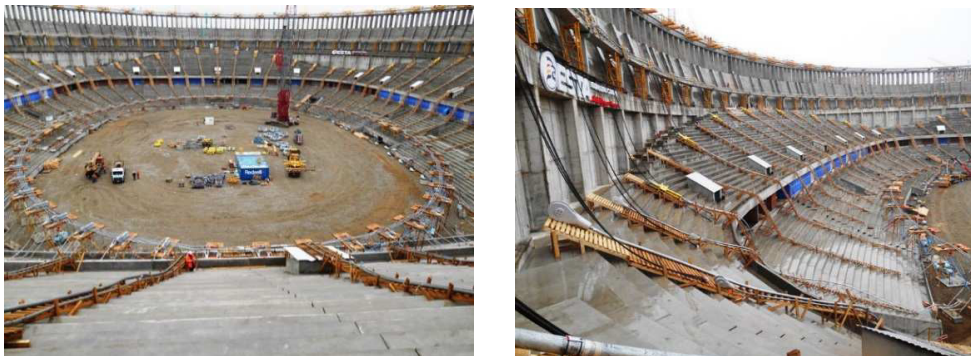

Fig. 11 Cables Lay Down

4. Clamps installation and spreader beams

Once the radial cables were laid down, hanger cable clamps were located at the corresponding marking positions and they were installed and tightened to connect hanger cables to radial cables, thus forming cable trusses along radial axis. After the lay down of the lower ring cables and before the lay down of the upper ring cables, ring cable connectors were installed on ring cables upon the corresponding platforms.



Fig. 12 Ring Cables Connector.

The spreader beams are temporary steel structures used to connect the radial cables to the pulling strands, they are made in two halves clamped around the radial cables and they transfer the pulling force of the strands to the cables. A stabilization nose is necessary to prevent the spreader beam from rotating; it is also important that the alignments of the fork sockets are correct to facilitate the insertion of the pins in the final configuration. The spreader beams were assembled on wooden platforms at the top end of radial cables.



Fig. 13. Spreader beam.

4.1. Installation and tensioning of bracings cables

Bracing cables were installed one by one, according to Designer procedure and cable tensioning started only after completion of their installation. Four bracing cables had to be tensioned simultaneously, in order to keep the structure sufficiently balanced. Installation and tensioning of bracing cables was performed as per Redaelli standard method.

5. Big Lift

The cable net of the Krasnodar Stadium consists of 16 tension ring cables, 112 radial cables and 56 diagonal cables. Once the tension ring was laid down on the ground, radial cables were attached to the tension ring connectors and disposed along corresponding axis for final pin connection. Strand jacks were installed on the upper compression ring and radial cables were pulled by temporary strands, lifting the entire cable net. The tension ring was lifted pulling each upper radial cable with two strand jacks.

It is plain to understand that such a challenging operation requires the greatest care and accuracy at each stage.

5.1. Preliminary activities

It was essential that all equipment was carefully overhauled and inspected prior to transportation on site, equipment testing being documented in details. Likewise, it was crucial to verify the strands resistance and their safety coefficient with respect to the expected loads.

5.2. Installation of Big Lift equipment

Working on such a large-scale structure, accessibility had to be taken into proper and careful consideration. Particularly, it was necessary to be able to operate promptly and smoothly on socket pins and spreader beams at each upper radial cable top anchorage point, where strand jacks were located.

At two sides of each upper radial cable anchoring plate, symmetric holes crossed the upper compression ring to allow for the installation of the pulling strands devices. Behind the compression ring, in correspondence of each hole, a contrast system for the jacks was adapted so that strands jacks worked parallel to the cables direction at the end of tensioning operations, when the forces involved are the largest. Sliding saddles for strands were temporarily connected inside the compression ring.

Every jacking system was connected with a control cable to the Lifting Control Centre, which was located in a control room on the top of the tribune, from where a full and good overview of site operations was guaranteed.

5.3. Cables lifting

Cables were lifted at 56 points strictly following the Design procedure. Some strand jacks had a nominal pulling capacity of 1.400 kN, while others had a nominal pulling capacity of 2.400 kN. Hydraulic pumps were used, to achieve an equal pulling speed on radial cables. The main target during lifting operation was to succeed in lifting the entire cable net from its supports minimizing the sliding.

At each step of cables lifting, topographic survey of the structure was executed to compare actual positions and theoretical values supplied by the Designer, as geometrical and tensional status of the roof had to be continuously monitored.

5.4. Pinning of cables

Cable nets was lifted until external sockets of lower radial cables could be easily pinned on their final anchor plates. At that point, lifting operation was interrupted and the pinning of lower radial cables was carried out. The cables were pulled manually towards the anchoring plate. Where necessary, due to relevant final cables force, the tensioning system was installed and the cable was pulled to its final position using jacks connected to hydraulic pump. As fork socket was in position, the pin was inserted and the tensioning operation was completed.

After pinning of lower radial cables, diagonal cables were connected to the lower compression ring. As the pinning of diagonal cables did not require considerable forces, it could be carried out using only a pulling device operated by hand.

As pinning of lower radial and diagonal cables was completed, tensioning of upper radial cables by means of strand jacks was continued until fork sockets reached their anchoring plates and the pins could be inserted, completing the big lift operations.

6. Conclusions and remarks.

The overall production process succeeded in delivery the supply within the required time schedule and quality target. Throughout the supply, the characteristics of each component were monitored and evaluated in order to guarantee the final output to be satisfactory.

Site activities planning and logistics proved to be accurate and efficient, all site activities were performed successfully. Despite the complexity of such a large building site and the challenge of several concurring site activities, the greatest control of each step related to the installation and tensioning of cable system was upheld. It was also guaranteed the necessary accessibility and broad outlook on working areas, so that any possible difficulty could be promptly detected and solved.