

DIAGNOSIS OF AN UNUSUAL STRUCTURAL INSTABILITY: THE CASE STUDY OF THE CATHEDRAL OF SAN LORENZO IN VITERBO

M.CANDELA^{1*}, M.EICHBERG², C.TARANTINO¹

¹Studio di Ingegneria Michele Candela,
via Circumvallazione 76, 83100, Avellino, Italy
e-mail: ing.mcandela@libero.it; arch.cristarantino@gmail.com

²Soprintendenza archeologia, belle arti e paesaggio per l'area metropolitana di Roma, la provincia di
Viterbo e l'Etruria meridionale
via Cavalletti 2, 00186, Rome, Italy
e-mail: sabap-rm-met@beniculturali.it, web page: <http://www.sabap-rm-met.beniculturali.it/>

Keywords: Historical Building, Masonry, Tensile Crack, Thermal Variations, FE Analysis

Abstract. *The cathedral of San Lorenzo is a Romanesque church sited in Viterbo (Lazio, Italy), founded in the XII century on a site characterized by a complex archaeological stratification. The building is a fine example of religious monumental architecture, built upon well-laid masonry walls, made of squared blocks of piperine stone and very thin layers of mortar. Its basilica-shaped plant is divided into three aisles by two rows of marble columns connected by arches. The structure, that has undergone many transformations during the centuries, was severely damaged during the II world war and a restoration executed in 1947 has brought it back to its romanese appearance.*

Currently, a peculiar crack pattern can be observed in the structures, which is mainly characterized by recurring sub-vertical fissures appearing on the keystones of the arches that run along the central nave.

The purpose of this paper is to illustrate the diagnostic path which enabled to rule out the most common damage mechanisms, as a main cause of the damages, and led to the identification of the most probable cause for the instabilities.

A critical reading of the geometry of the cracks, supported by several static verifications, resulted in the exclusion of mechanisms associated with the arches thrust actions or with the compressive stresses in the walls. The hypothesis of soil settlement is rejected by the mechanical characteristics of the foundation soil, provided from a previous study.

An original diagnostic hypothesis of tensile stresses induced by thermal variations is formulated and a fully coupled temperature-displacement analysis is carried out, with the FE software Abaqus, to investigate the effects of the thermal gradient on structures behavior.

1 INTRODUCTION

The history of structural damages in historical constructions went hand in hand with the evolution of constructive systems. The rise of new structural conceptions has been constantly followed by the occurrence of new unknown instabilities, which highlighted the lacks of its design ^[1].

Based on this experience, a specific technical discipline developed, which provides advanced analytical methods for the diagnosis of the structural instabilities and new systems for classifying the recurrent damages ^[2]. In this regard, the damage schemes referable to masonry splitting, to foundation settlements and other phenomena affecting the masonry structures are well known ^[3]. Not infrequently, it is possible to find these damage schemes combined together in the same building. Yet, a keen eye is still able to distinguish them and assess their prominence. Nevertheless, there are cases, as that of the Cathedral of Saint Lorenzo, where the well known patterns are not identifiable and hence the diagnostic methodology has to proceed by steps, through studies and investigations that progressively lead to the exclusion of the main damage mechanisms.

Based on these considerations, this study presents the diagnosis path that led to the identification of the probable, and unusual, cause of the building instability.

The object of study is the cathedral of Viterbo (fig.1), a fine example of monumental religious' architecture. The building is affected by a peculiar crack pattern which develops along the main nave walls. On the base of the correspondence between damage intensity variations and temperature distribution along the walls, the hypothesis of thermal variations inducing tensile stresses is formulated. A fully coupled temperature-displacement analysis is carried out with the FE Abaqus software to investigate the behavior of the walls under thermal variations.

In section 2 a building description is provided, together with historical and context information; Section 3 illustrates the crack pattern and the in site inspections; The FE model and the results of the analyses are presented in Section 4.

Register for free at <https://www.scipedia.com> to download the version without the watermark



Figure 1: The Cathedral of Saint Lorenzo. View from the square outside.

2 THE CATHEDRAL OF SAINT LORENZO

2.1 Description of the monument

The Cathedral of Saint Lorenzo lies on the highest hill of the city of Viterbo (Lazio, Italy), known as the "City of Popes", since it hosted the papal seat between 1257 to 1281. The building was founded in the XII century on the remains of an ancient Roman temple. The original core, in Romanesque style, had a limited extension. The current layout is the result of numerous transformations and enlargements related to the increase in importance of the site over the centuries.

A transept was added in 1192. The Romanesque facade was demolished in the 1570 and replaced with a new one in Renaissance style^[4]. During the XVII century, a new Baroque skin was given to the inside of the building and vaulted structures were built on the aisle spans to hide the timber structures of the roofs.

Severe damages were caused by the bombing of the II World War and significant restoration interventions were carried out which canceled the stratifications and brought the building back to its Roman style shape^[5].

The current layout of the building shows a typical basilica scheme with three aisles, a transept contained in the building width and three ending apses (fig.2).

The three aisles develop for eleven spans, scanned by monolithic columns in piperine stone and marked by double ring round arches, which separate the central aisle from the lateral ones.

Over the arches, two walls elevate themselves beyond the lateral aisle roofs, defining the central nave space. A protruding cornice, supported by corbels, runs along these walls, dividing the nave arcade from the clerestory.

The cathedral has a total length of 60 meters and covers a 20 meters width. The nave is 35 meters long and 22 meters high at the top of the truss roof, while the aisles reach the height of 11 meters. The masonry walls, with an average thickness of 1,00 m, are made of squared blocks, in piperine stone and thin layers of mortar. The central nave has a truss roof, while the aisles are covered by a single pitch tiled roof. The foundation structures are of the shallow type (fig.3).

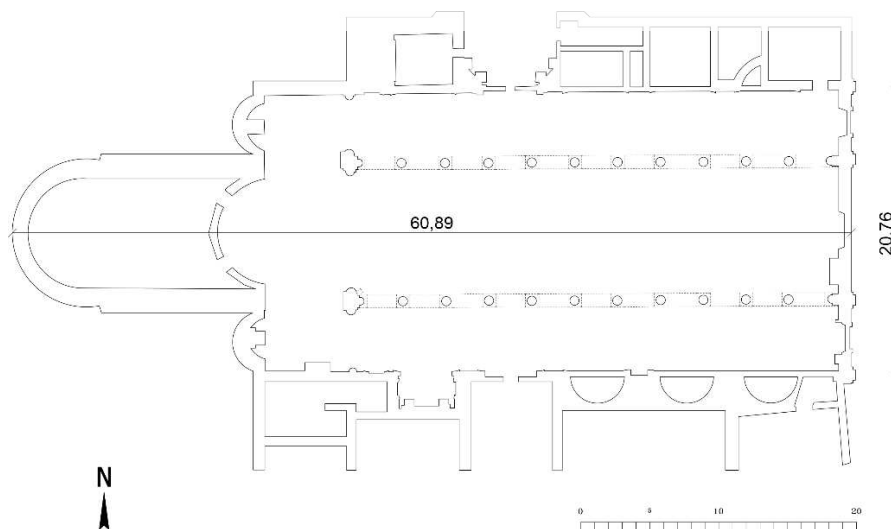

Figure 2: The Cathedral plan (dimensions in meters).

2.2 The foundation soil

The geomorphology of the site where the Cathedral is settled is characterized by the presence of volcanic formations from the Vicano district.

In particular, the formation named “Unità del tufo rosso a scorie nere del Vicano” is detectable, with thickness vary between 5 and 30 meters. Anthropic caves are detectable.

The formation is a reddish coloured tuff, with black slags made of lapillus, light plinian pumice and pyroclastic flow deposits.

The bedrock shows the following Geotechnical characteristics: 1,9 g/cm³ weight in the unit; 1,9 – 2,0 N/mm² compressive strength; 1,7 kg/cm² tensile strength. The values are compatible with the load conditions. Differing from the loose soils, which are susceptible to compaction under load also in the long term, this bedrock is not prone to sagging phenomena. Small displacements can only occur contextually to the application of the load. Thus, considering the long time passed since the cathedral construction, there are low probabilities of the occurrence of absolute or differential settlements in the recent time.

3 THE DAMAGE SURVEY AND DIAGNOSTIC TESTING

3.1 Description of the crack pattern

The building exhibits a peculiar crack pattern which exclusively affects the high walls bounding the central nave. The damage occurs at half height of the walls and, specifically, at the level of the arches separating the aisles, where sub-vertical fissures recurrently appear in the proximity of the keystones (fig.3). The cracks start at the intrados of the arches and rise up for few meters, disappearing immediately after the cornice adorning the walls. The damage doesn't involve any fracture of the stones and the cracking path follows the arrangement of the mortar lines.



Figure 3: Lesions on the arches keystones along the nave wall.

To a close observation, the fissures' edges appear coplanar and aligned. This configuration corresponds to a horizontal displacement between the two portions of the wall the crack separates, and it can be possibly caused by a tensile stress, developing into the plane of the wall and acting parallel to its longitudinal axis.

As acknowledged by scientific literature and professional experience, this mechanism is characteristic of some recurrent phenomena: crushing, combined bending and axial loading, foundation settlements with a horizontal component [6].

The first two conditions can be excluded, considering the magnitude of the loads, the stress paths in the walls and the mechanical characteristics of the masonry structures investigated through in-site inspections.

The hypothesis of a foundation settlement is incompatible with the extension of the damage, limited to a confined area of the wall, and with the cracks' constant amplitude. Moreover, it would be inconsistent with the geomorphology of the site and the characteristics of the soil analysed by previous geognostic studies.

A correspondence between the variation of damage's intensity and that of the walls thermal conditions can be observed. The crack pattern shows a symmetry in its localization but is prominent in the south wall with respect to the north wall. The damage concentrates in a border region between two areas characterized by different thermal conditions: the upper clerestory, highly exposed to the solar radiation, and the arcade below, protected by the aisles' roofs.

Based on these considerations, it appeared appropriate to make the assumption of the presence of tensile stresses, induced by a thermal gradient developing in the plane of the nave walls (fig.4).

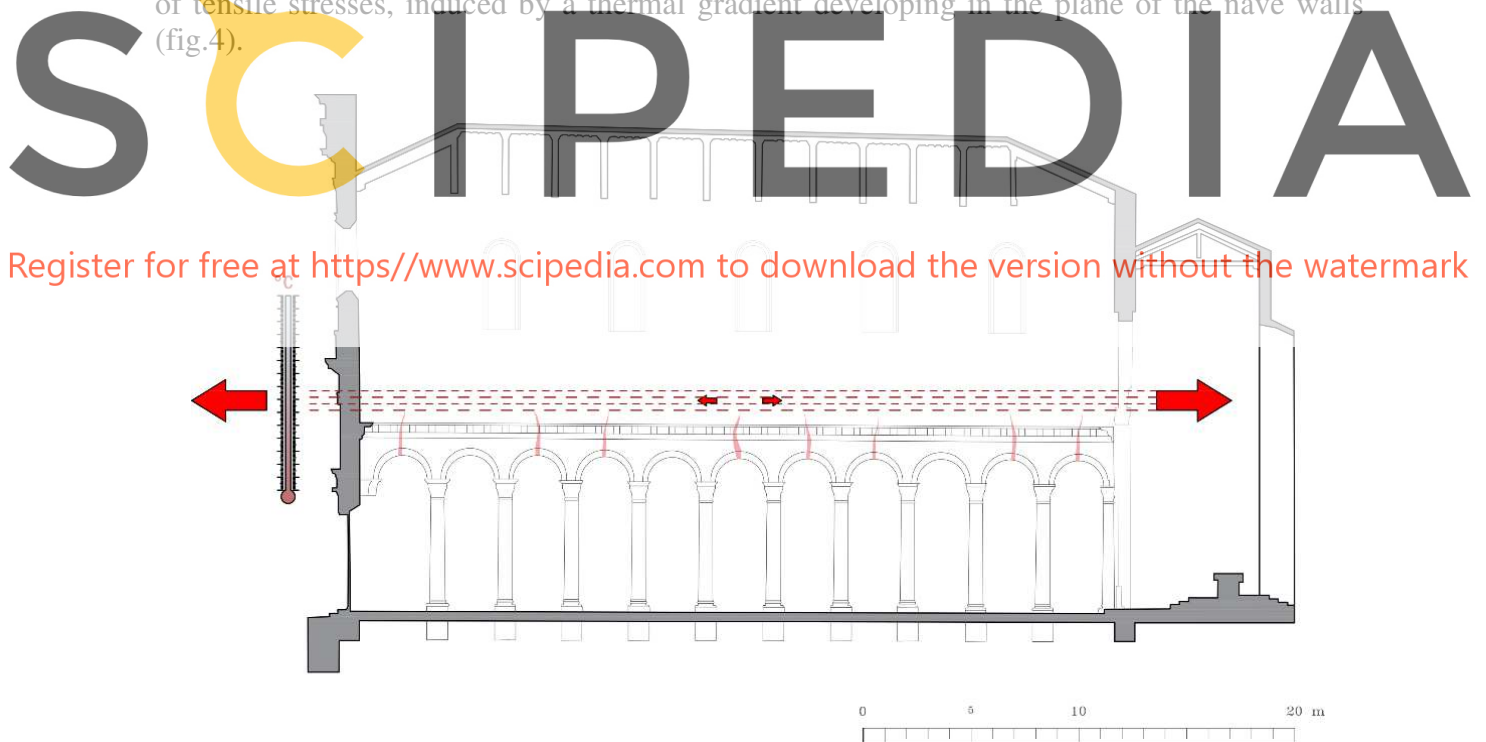

Figure 4: Longitudinal Section of the cathedral. Scheme of the effect produced by the thermal gradient inside the nave wall.

3.2 In-site inspections and material characterization

Based on the hypothesis of damages induced by thermal variations, a diagnostic campaign of non destructive tests has been planned.

Ultrasonic tests were performed to estimate elastic and mechanical characteristics of the masonry. As it is known from scientific literature, the recurring values of ultrasonic pulse velocity, referred to masonry, range between 1000 and 2000 m/s. Velocity values lower than 1000 m/s reveal the presence of fractures or voids in the thickness. Values higher than 2000 m/s are attributed to well constructed masonry, endowed with high compressive strength values. The average value of velocity measured on the two walls is 3100 m/s.

Extensimetric tests were executed to assess the stress conditions in the walls affected by the damage. Eight tests were performed in the proximity of the arches keystones, selecting the most damaged spans of both the walls. Each test has consisted in the measurement of the stresses value in the horizontal direction in two points vertically aligned: the first at the arch intrados, the second close to the cornice. The two walls are characterized by different stress conditions. Except for the damaged areas, in the north wall the horizontal compressive stresses values vary but are constantly detected. On the south wall the values of the compressive stresses are significantly low near the cornice and frequently vanish at the arches' intrados. This result highlights that there are tensile stresses acting in the region between the arches and the cornice, where the thermal variation is greater.

Temperature measurements were carried out to estimate the thermal gradient along the wall's height and between the external and the internal face. The measurements were taken on the south wall, which is the most exposed to solar radiation (fig.5), in the month of August, during the warmer hours. The results are reported in Table 1.



Figure 5: Satellite view of the cathedral and schematization of the sun path.

Table 1: Inside and Outside temperature values (°C) on the south wall, at different heights.

Height (m)	TEMPERATURE (°C)			
	12.00 am		1.15 pm	
	Indoor	outdoor	Indoor	outdoor
18.00	26,6	32,0	27,5	39,0
16.00	26,8	32,4	27,3	39,0
13.00	26,6	32,5	27,2	38,8
11.80	26,7	32,2	27,2	38,8
8.00	26,5	-	27,1	-

4 FULLY COUPLED TEMPERATURE-DISPLACEMENT ANALYSIS

The analytical study of the Duomo of Viterbo colonnade behavior under thermal excursion is carried out using the Abaqus v.6.14 Finite Element software. A numerical model is implemented on the basis of the real geometric dimensions of the columns, arches and walls of the colonnade, as well as on their constitutive materials, represented by *piperino of Viterbo stones for columns, walls and arches*. Mechanical characteristics of materials are derived from the Italian Standard [Circular no. 7 of 21/01/2019] using a LC2 confidence factor. Table 2 summarizes the mechanical characteristics used.

Table 2: Mechanical characteristic: w specific weight; E elastic modulus; α thermal expansion coefficient; ν Poisson's ratio; λ thermal conductivity; c specific heat.

Masonry type	w [kN/m ³]	E [N/mm ²]	ν [-]	α [1/°C]	λ [W/m·°C]	c [kJ/Kg·K]
Piperino	21,0	5500	0,5	$0,6 \times 10^{-5}$	0,4	1,3

Register for free at <https://www.scipedia.com> to download the version without the watermark

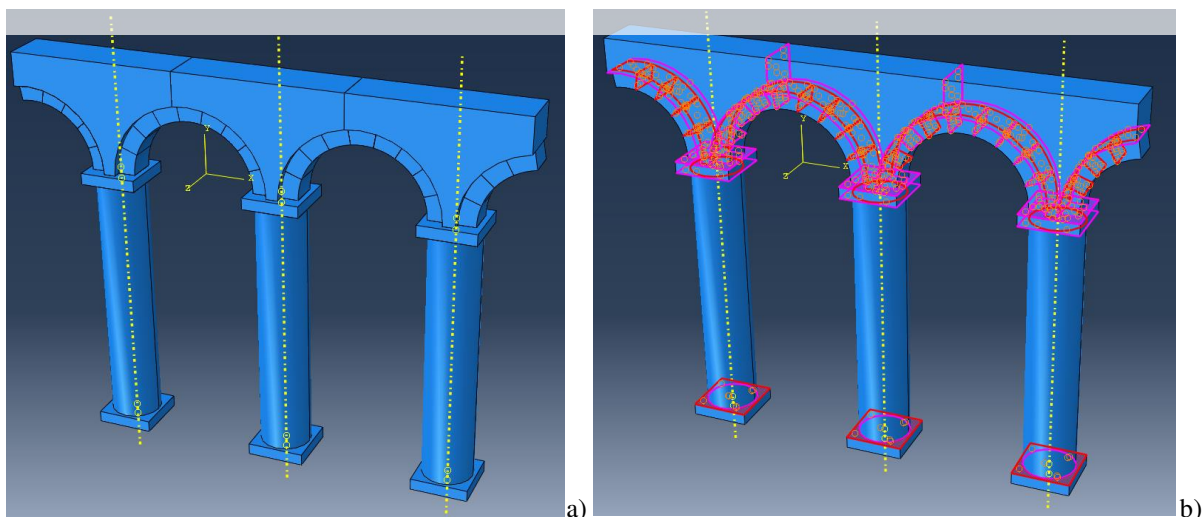

Figure 6: The FEM model of the colonnade portion considered (a) and constraints among masonry parts (b)

In the modelling phase, a significant portion of the colonnade, consisting of three columns inferiorly and superiorly supported by masonry bases, two arches and a part of masonry wall above arches, is considered. All the FE model parts are modelled with C3D8R brick elements. The masonry arches are modelled as individual ashlar, while columns and masonry bases and wall are considered as unique finite elements (Figure 6a). Columns are superiorly and inferiorly constrained to the masonry bases by a “tie” contact; the arches are connected to the walls by a surface-surface contact (Figure 6b), where “hard” contact in case of axial loads is considered and friction and thermal coefficients of 0.5 and 1, respectively, is used. Also, ashlars are connected to each other by means of the surface-surface contact above described.

The structure is fixed to the ground through fixed supports; in order to simulate the colonnade continuity, also the two end parts of the colonnade are fully restrained (Figure 7).

A distributed load is applied at the top of the masonry wall above arches aiming at considering the actions deriving from unmodelled elements, such as the upper masonry wall and the above roof (Figure 8). A further boundary condition is considered, namely the temperature of the external and internal faces of the wall.

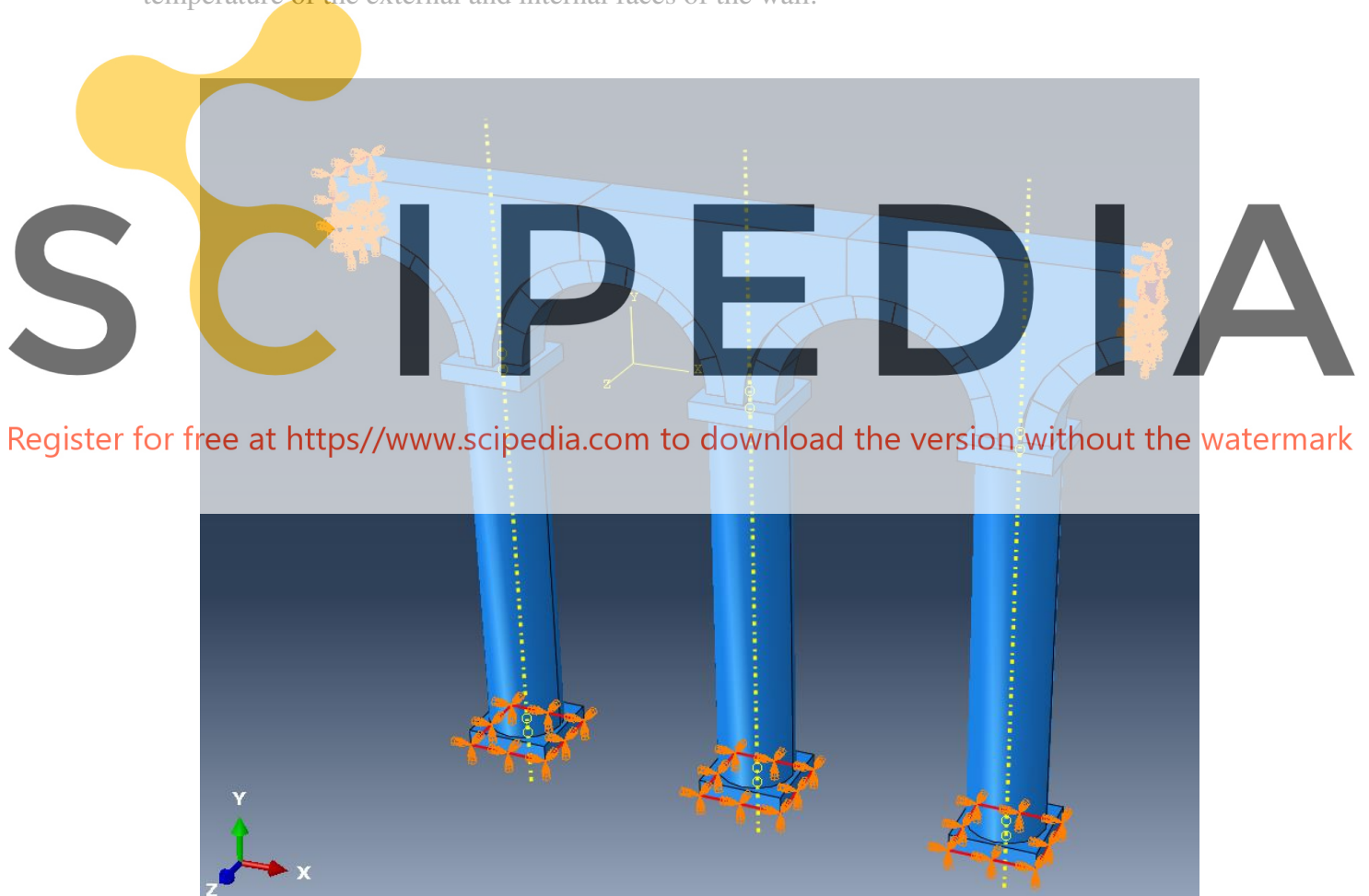

Figure 7: Restraint conditions of the FEM model.

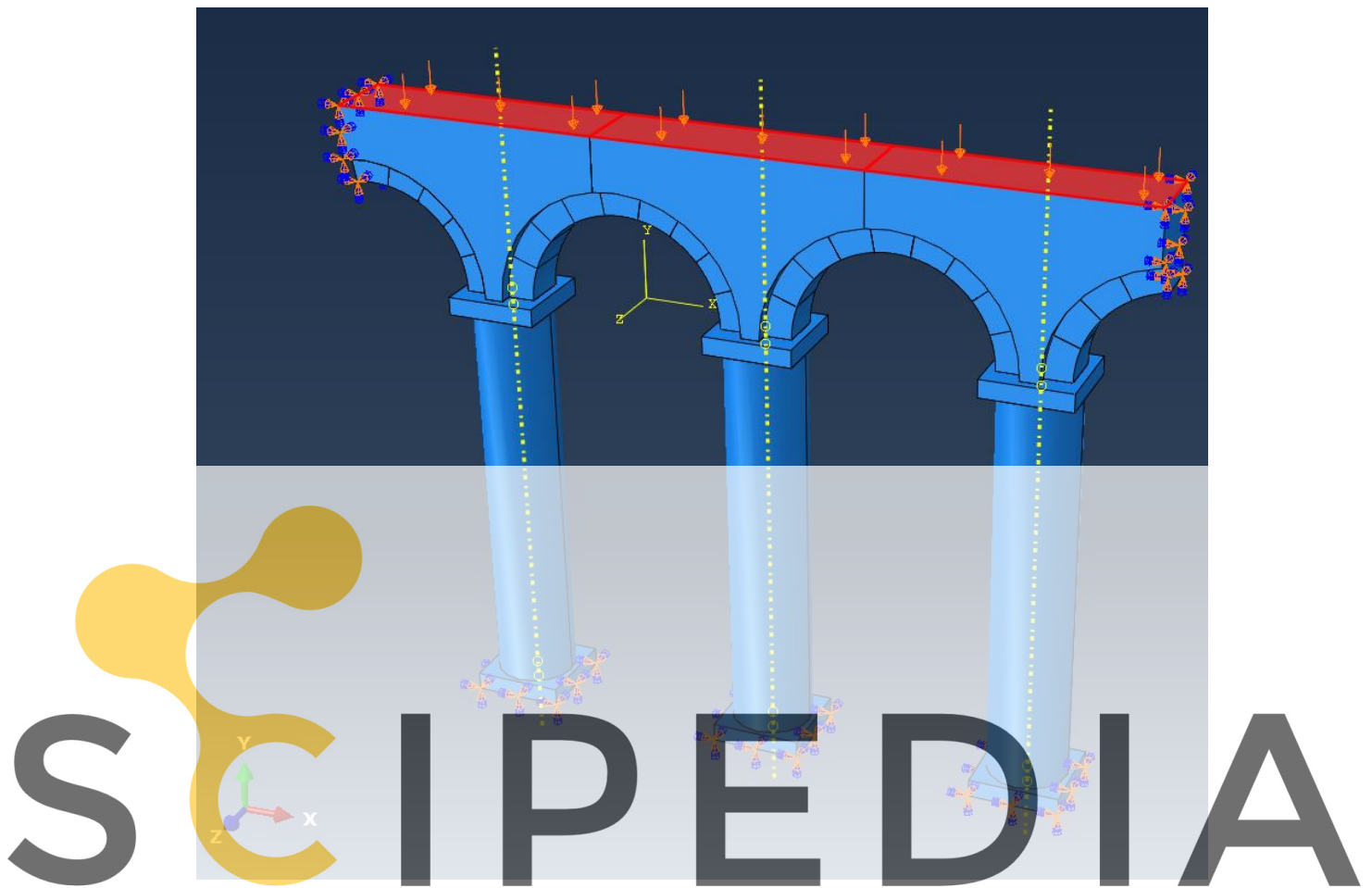

Figure 8: Loads applied on the top surface of the colonnade to simulate the presence of the above wall and roof.

Register for free at <https://www.scipedia.com> to download the version without the watermark

Temperature values on these faces, namely 38.9°C on the external face and 27.3°C on the internal one (Figure 9), refer to the experimental data recorded inside and outside the church in the summer season. These values have a subsequent digression up to the winter conditions, where internal and external temperatures are approximately assumed as equal to 11°C and 0°C , respectively. In addition, a heat flux of 10°C from the bottom to the top, which propagates between arches and the above wall, is considered. The colonnade parts are discretized with a mesh having side length of 10 cm (Figure 10), which guarantees the best accuracy of results with the minimum analysis time.

The numerical analysis takes place through two consecutive steps. The first step concerns a “static general” analysis, where the colonnade behavior subjected to the self-weight and the distributed loads coming from the above wall and roof structures is studied. The second step deals with a “fully coupled temperature-displacement” linear analysis. This type of analysis is chosen because stress analysis is dependent on the temperature distribution in the structure and the temperature allocation depends on the stress solution. The numerical analyses are developed by Newton's partial derivative resolving technique and direct iterative method, dividing the analysis time into amplitude increments equal to 0.1 s.

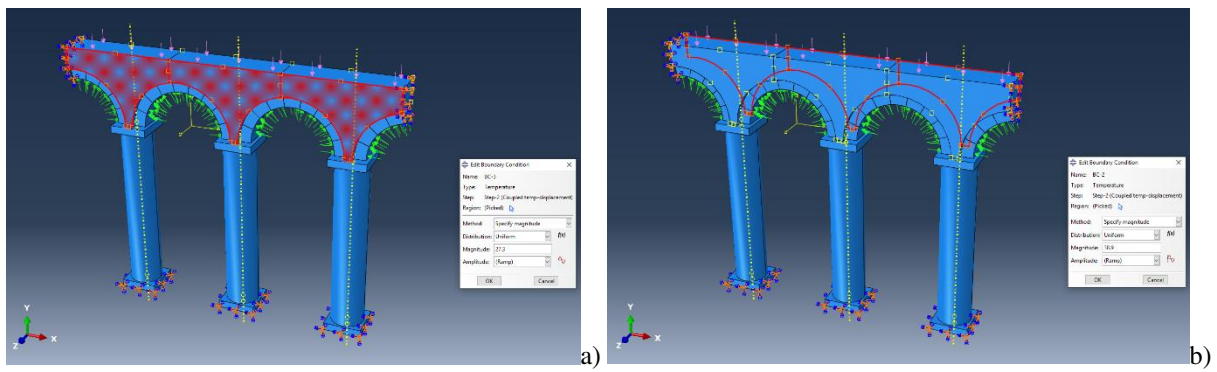

Figure 9: Temperature fields applied on the internal (a) and external (b) sides of the structure.

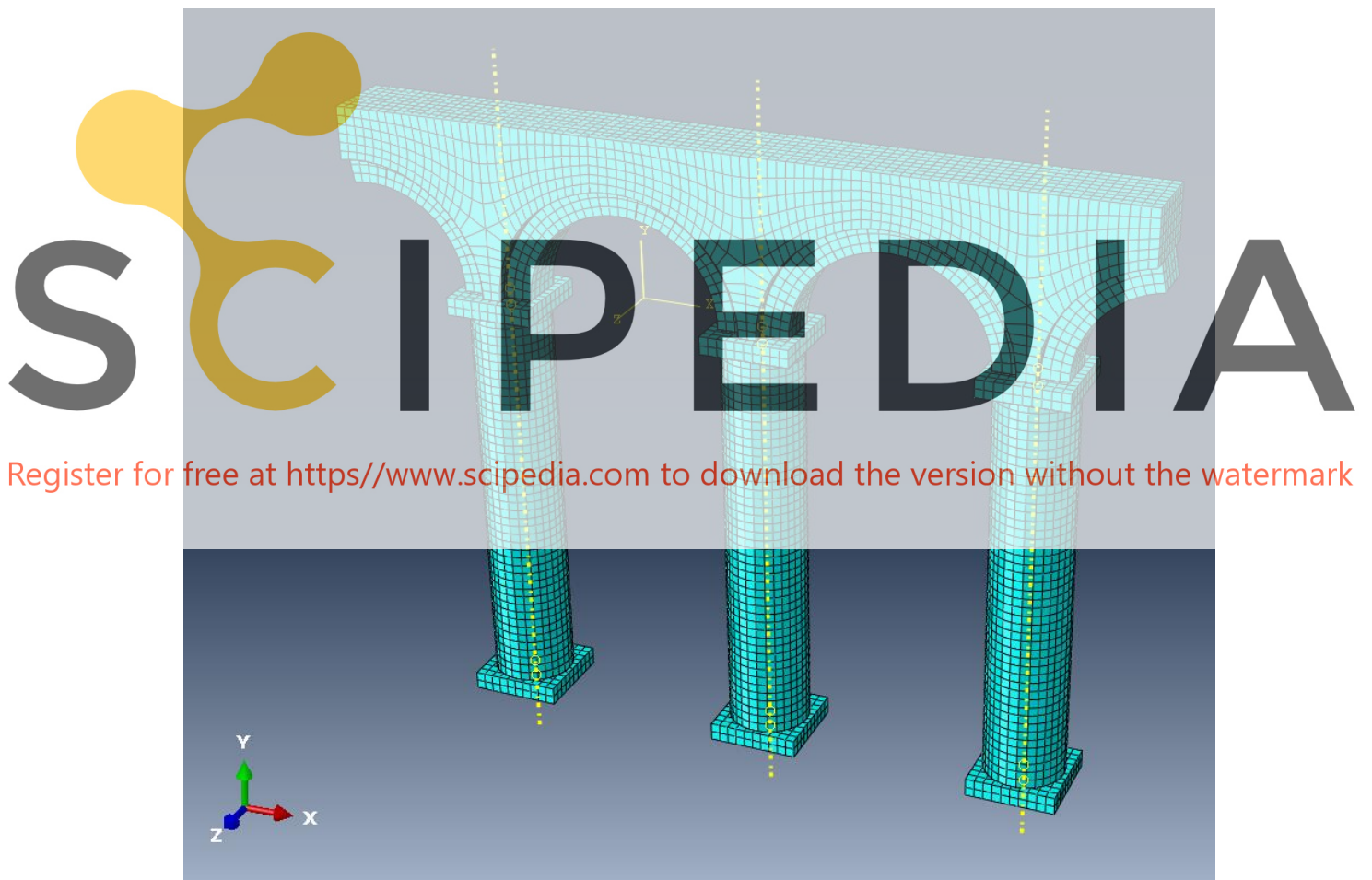

Figure 10: The discretization of the colonnade FEM model.

The results of the numerical analyses on the colonnade FEM model with reference to the summer and winter conditions are depicted in Figure 11, where a focus on the stress distribution in the model part represented by arches and upper wall only is made.

Results of Figure 11a show that in the hot season a concentration of tensile stress with more or less the same magnitude of $1,297 \times 10^4 \text{ N/m}^2$ (0,01297 MPa) occurs in the central part of arches and in the above wall. Such a result is very close to the one attained under experimental way in the church, where in the arch internal side a tensile stress of 0,01 MPa activating the cracks in the mortar joints is detected. This means that the orange area observed in Figure 11a represents a potential damage zone where a crack pattern could develop. Contrary, in winter condition (Figure 11b), it is noted that, as temperatures decreases, tensile stresses values increase in intensity, but the extension of the masonry zone subjected to tensile actions is reduced.

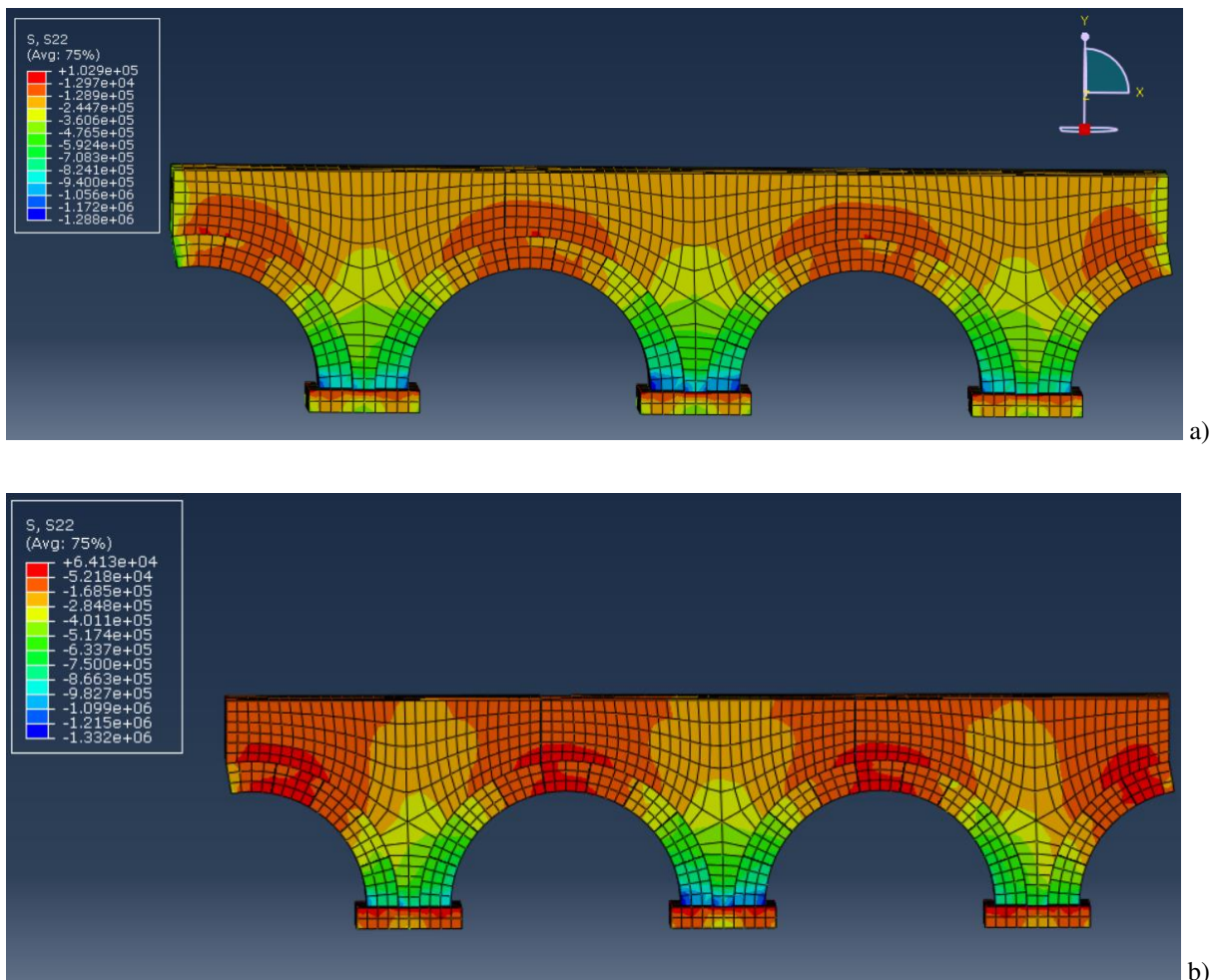

Figure 11: Stress distribution in the structure in summer (a) and winter (b) conditions.

4 CONCLUSIONS

In this paper the damage analysis of the cathedral of Saint Lorenzo in Viterbo is presented. The building is a religious monumental architecture from the XII century, built upon well-laid masonry walls, made of squared blocks of piperine stone and very thin layers of mortar.

The structures exhibit an unusual crack pattern, concentrated along the nave walls, not referable to classic and most common damage mechanisms.

Based on the correspondence between damage intensity variations and temperature distribution along the walls, an original hypothesis of tensile actions induced by thermal variations has been advanced. A Finite Element analysis was carried out with the FE software Abaqus v.6.14 to investigate the behavior of the masonry walls under thermal variations, in both cases of the summer and winter radiation. The results of the analyses are in good agreement with the stresses values measured in the experimental tests and the existent damage scenario.

The reason of the occurrence of this damage in Saint Lorenzo Cathedral, and not in other buildings with same orientation and similarly exposed to solar radiations, lies in the quality of the masonry and the stones composing it. Due to the high strength of the piperine stone and the poor presence of mortar, the masonry shows a low ductility, needed to dissipate the thermal actions, and behaves as a wall of rigid blocks. This mechanical behavior, extended to the whole length of the walls produces the observed damage.

The reason of the recent occurrence of the cracks, although the building has been always exposed to solar radiation, is to be found in the increase of the average stagional temperatures, traceable to the recent climate changes.

Acknowledgements. The Authors acknowledge: Eng. Antonio Formisano, Eng. Generoso Vaiano and Nicola Junior Petrucci, who contributed to develop the numerical analyses; Roberto Delgado, Gerardo Antonello, Giuseppe Cicala and Eng. Alfredo Galasso, who worked on the in-site inspections and surveys; Arch. Federica Cerroni from the Archeologic, Fine Arts and Landscape Superintendence of Rome municipality, for the technical support in the study of the cathedral.

REFERENCES

- [1] Benvenuto, E., *La scienza delle costruzioni: e il suo sviluppo storico*. Firenze: Sansoni (1981).
- [2] Sparacio, R., *La scienza ed i tempi del costruire*, UTET Università (2012).
- [3] Heyman, J., *The Stone Skeleton: Structural Engineering of Masonry Architecture*, Cambridge: Cambridge University Press (1995).
- [4] Valtieri, S., Bentivoglio, E., *Viterbo nel Rinascimento*, (2012).
- [5] Egidì P., L'Archivio della cattedrale di Viterbo. In: *Bollettino dell'Istituto Storico Italiano e Archivio Muratoriano*, Roma: Sede dell'Istituto Palazzo dei Lincei 28 (1906), pp 7-381.
- [6] Mastrodicasa, S., *Dissesti statici delle Strutture Edilizie*. Milano: Hoepli, (2006).