

PROCEEDINGS OF SPIE

[SPIDigitalLibrary.org/conference-proceedings-of-spie](https://spiedigitallibrary.org/conference-proceedings-of-spie)

Assembly integration and testing facility for the x-ray telescope of ATHENA

Valsecchi, G., Bianucci, G., Marioni, F., Vernani, D., Zocchi, F. E., et al.

G. Valsecchi, G. Bianucci, F. Marioni, D. Vernani, F. E. Zocchi, T. Korhonen, M. Pasanen, G. Pareschi, M. Bavdaz, Eric Wille, D. Doyle, "Assembly integration and testing facility for the x-ray telescope of ATHENA," Proc. SPIE 11852, International Conference on Space Optics — ICSO 2020, 1185221 (11 June 2021); doi: 10.1117/12.2599346

SPIE.

Event: International Conference on Space Optics — ICSO 2021, 2021, Online Only

International Conference on Space Optics—ICSO 2020

Virtual Conference

30 March–2 April 2021

Edited by Bruno Cugny, Zoran Sodnik, and Nikos Karafolas



Assembly integration and testing facility for the x-ray telescope of ATHENA



International Conference on Space Optics — ICSO 2020, edited by Bruno Cugny, Zoran Sodnik, Nikos Karafolas, Proc. of SPIE Vol. 11852, 1185221 · © 2021 ESA and CNES
CCC code: 0277-786X/21/\$21 · doi: 10.1117/12.2599346

Proc. of SPIE Vol. 11852 1185221-1

Assembly Integration and Testing facility for the X-ray Telescope of ATHENA

G. Valsecchi, G. Bianucci, F. Marioni, D. Vernani, F. E. Zocchi

T. Korhonen^a, M. Pasanen^a, G. Pareschi^b, I. Ferreira^c, M. Bavdaz^c, E. Wille^c, D. Doyle^c

Media Lario S.r.l., Località Pascolo, 23842 Bosisio Parini (LC), Italy

^aOPTEON Oy -Väisäläntie 20, FI-21500 PIIKKIÖ, Finland

^bINAF Osservatorio Astronomico di Brera, Via E. Bianchi 46, 23807 Merate, Italy

^cEuropean Space Agency, ESTEC, Keplerlaan 1, NL-2200 AG Noordwijk, The Netherlands

giuseppe.valsecchi@medialario.com; phone +39 031 867111; medialario.com

ABSTRACT

The optics of ATHENA (Advanced Telescope for High-ENERgy Astrophysics) consists of several hundreds of Silicon Pore Optics mirror modules integrated and co-aligned onto a Mirror Assembly Module (MAM). The selected integration process exploits an optical bench to capture the focal plane image of each mirror module when illuminated by an UV plane wave at 218 nm. Each mirror module focuses the collimated beam onto a CCD camera placed at the 12 m focal position of the ATHENA telescope and the acquired point spread function is processed in real time to calculate the centroid position and intensity parameters. This information is used to guide the robot-assisted alignment sequence of the mirror modules.

The ATHENA Assembly Integration and Testing (AIT) facility has been designed and is now under construction. It consists of a vertical tower, in which clean room conditions are maintained. Inside the tower, the MAM is supported at ground level on a gravity release system and a robot device above the MAM is used for alignment of the SPO Mirror modules. A paraboloid mirror that collects the light from an ultraviolet point source and generates a single reference plane wave large enough to illuminate the 2.6 m aperture of the X-ray telescope is placed 6 m below the MAM, whereas a CCD camera for the detection of the focused beam is placed at the top of the tower, 12 m above the MAM.

The 2.6 m parabolic mirror is already in the polishing phase and the related mechanical hardware is in manufacturing.

Keywords: X-ray optics, X-ray telescopes, ATHENA, Silicon Pore Optics, Integration, Optical Alignment.

1. INTRODUCTION

The ATHENA (Advanced Telescope for High-ENERgy Astrophysics) mission [1] of the European Space Agency is based on an X-ray telescope with a focal length of 12 m and an angular resolution of 5 arcsec half energy width (HEW). The telescope consists in a 2.6 m circular supporting structure on which about 600 Silicon pore optics (SPO) mirror modules (MM) [4] are integrated. Media Lario and a scientific and industrial team composed by ADS International, BCV Progetti, Cosine, INAF-OAB, and TAS-I have developed the process for the alignment and assembly of the MMs into the ATHENA telescope within the 1.5 arcsec (1 arcsec goal) [5] error budget allocated for integration. The process has the following distinguishing characteristics:

- implementation in standard ISO 5/6 cleanroom (no vacuum infrastructure needed);
- integration of 2 MMs per day, equivalent to 2-year total integration time for the entire telescope;
- arbitrary integration sequence of the 600 SPO MMs;
- option to remove, re-align, or replace any MM in any integration sequence scenario;
- full-telescope illumination, to monitor the optical performance during integration;
- easy telescope dismount/realign procedures for intermediate tests at X-ray facilities.

The alignment and integration concepts consist in using a vertical optical bench to capture the focal plane image of each SPO MM while illuminated by a reference plane wave at a wavelength of 218 nm. The light emitted by the UV source is reflected by a parabolic mirror to generate a beam collimated to better than 95 km, thus simulating illumination from deep

space. The Mirror Module focuses the collimated beam onto a CCD camera placed at the focal position and the acquired point spread function (PSF) is processed in real time to calculate the centroid position and intensity parameters. This information is then used to guide the robot-assisted alignment sequence.

The simplicity, precision, and accuracy of this process is based upon the fact, that the centroid position of the UV focal image and the X-ray focal image correspond. This is supported by simulations and confirmed by X-ray measurements at the PANTER test facility [6] in Munich.

The same integration process has been successfully used in all major X-ray missions, from Beppo-SAX, SWIFT, XMM-Newton, eROSITA and Einstein Probe [7].

2. INTEGRATION FACILITY

The conceptual scheme of the integration facility is shown in Figure 1.

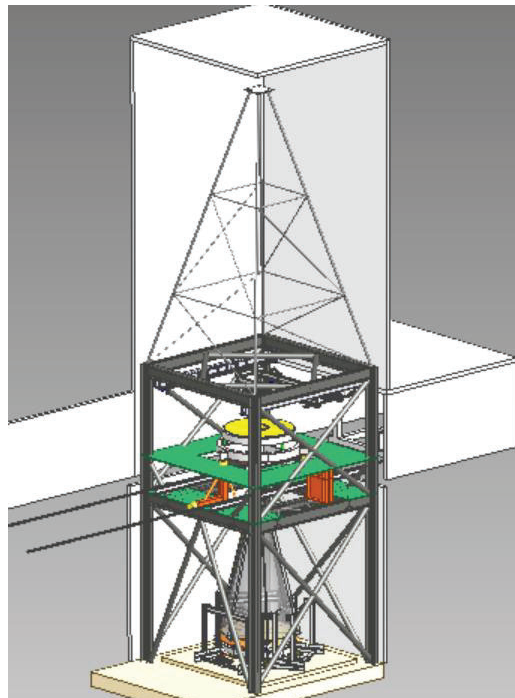

Figure 1. UVOB Cross section.

It consists of:

- Reinforced concrete foundation block, designed for accommodation of the AIT facilities.
- External well made of concrete diaphragms technique.
- Jet Grouting technique to assure water tightness.
- Water proofing membrane and inner wall of the underground facility
- Carbon Steel Mirror-Cell supporting the UV parabolic collimator mirror.
- UV parabolic collimator mirror.
- CFRP frame to maintain the UV source in the focus position of the parabolic collimator.
- XYZ stage for fine tuning of the UV focusing.
- Steel base frame supporting the ATHENA Mirror Assembly Module (MAM).
- Gravity release system for the ATHENA MAM.
- CCD positioner, XYZ stage on top of the tower.
- Handling and Alignment Devices (HAD) with their XYZ mechanism for the integration of the SPO MM.

The UVOB building comprises two main parts: one in the ground, approximately 6.5 m deep, and one above the ground, which is 17 m high.

From the structural point of view, the underground area consists in a rectangular well (Figure 2) with a large watertight reinforced wall made of a series of concrete diaphragms. The bottom slab is also made of concrete with waterproof materials inserted in between the parts.

The concrete slab is also supported by underground layer of soil that is treated by Jet Grouting technique. This approach improves mechanical and permeability properties of the soil by using high-speed jets of water/cement mixtures injected at high pressure into the soil.



Figure 2. Concrete diaphragms, 13.5 m deep, define the rectangular well

Both the lateral diaphragms and the Jet Grouting layer are realized before beginning the excavation, which is then done in a predefined volume. After the excavation is completed, the bottom concrete slab is realized and anchored to the diaphragms along its lower perimeter.

The building above the well contains the assembly and integration facility as well as the VERT X facility. The latter is the ATHENA X-Ray calibration instrument (see Figure 3).

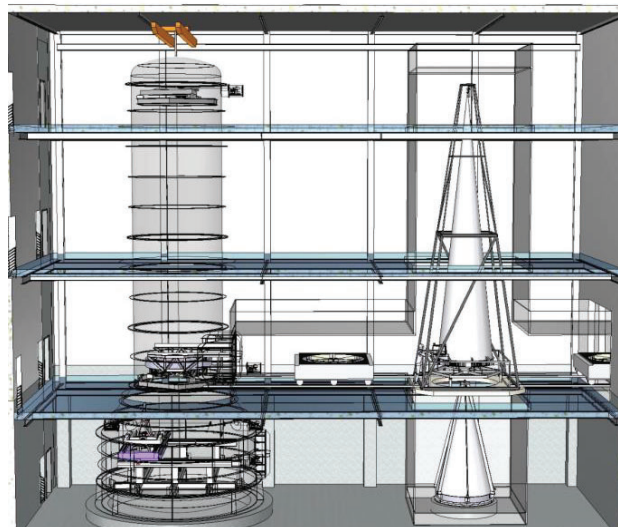

Figure 3. ATHENA building with VERT X (left) and ATHENA AIT (right)

The UVOB is contained in an ISO 5 clean room that takes the form of a square tower, with an area of $6 \times 6 \text{ m}^2$, extending down to the parabolic collimator and up to the detector. Requirements of position stability allow a maximum total focal length variation of 0.096 mm; therefore, the temperature inside the tower must be maintained within $\pm 1 \text{ }^\circ\text{C}$.

A CCD is suspended at the focus of the ATHENA telescope by means of a CFRP tower. The CCD is mounted on the tower by means of X, Y, Z translating stages for its fine positioning.

Laser trackers will routinely monitor the positions of the CCD, the ATHENA telescope, the collimator mirror, and the UV source. To this purpose, retroreflectors are mounted on each component. Tiltmeters are also foreseen to verify the stability of the entire system and to maintain its optical axis parallel to the local gravity direction.

The laminar flow of the air conditioning (0.36-0.45 m/s) must be controlled in order to avoid fluctuations that can cause micro-movement of the CCD.

3. THE UVOB COLLIMATOR

The 2.6 m collimator mirror is placed in the AIT tower at 6 m under ground level. The area provides a dry, water-tight, and vibration-isolated accommodation for the collimator supporting cell.

The latter consists in a carbon steel, ribbed structure, resting on the foundation slab of the well. The collimator mirror is equipped with 54 pads in metal with elastomeric parts. The collimator cell allows adjusting the collimator with respect to the gravity direction by three tip/tilt mechanisms. On the collimator side, a series of Invar pads are bonded to interface the CFRP structure that supports the UV source.

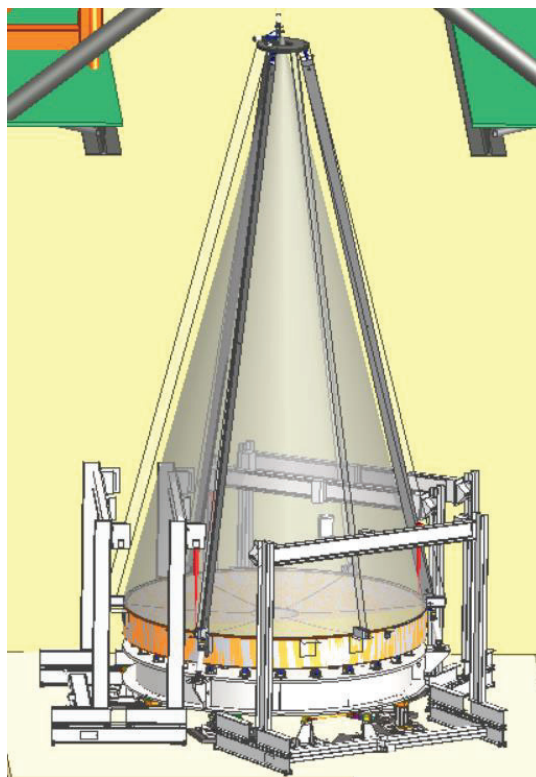

Figure 4. UV source supporting structure (above the mirror) and the 54 pads below the mirror.

At the top of the CFRP structure, X, Y, Z translating stages are mounted to hold the fiber optics of UV source. The design of the CFRP structure allows a good circulation to the air of the conditioning system.

The weight of the CRFP beams and structure itself is compensated by three actuators, which load the cell without inducing any deformation on the collimator mirror surface.

Since the collimator mirror will be polished while resting on the same 54 pads mentioned above, the deformation under gravity is absorbed by the polishing error budget. When installed on the UVOB cell, the surface error should be the same obtained in the polishing configuration.

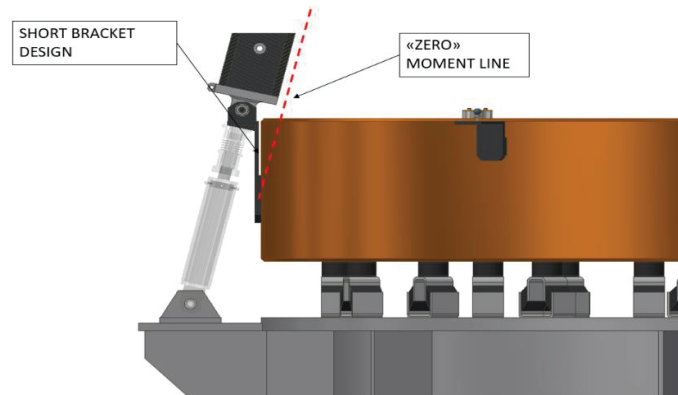

Figure 5. Gravity release mechanism for the 3 legs of the CFRP structure.

A picture of the 2.6 m collimator mirror at OPTEON Oy is shown in Figure 6. Completion of the polishing phase is foreseen in March-April 2021. Aluminum coating is planned at the CALAR ALTO OBSERVATORY in May 2021.

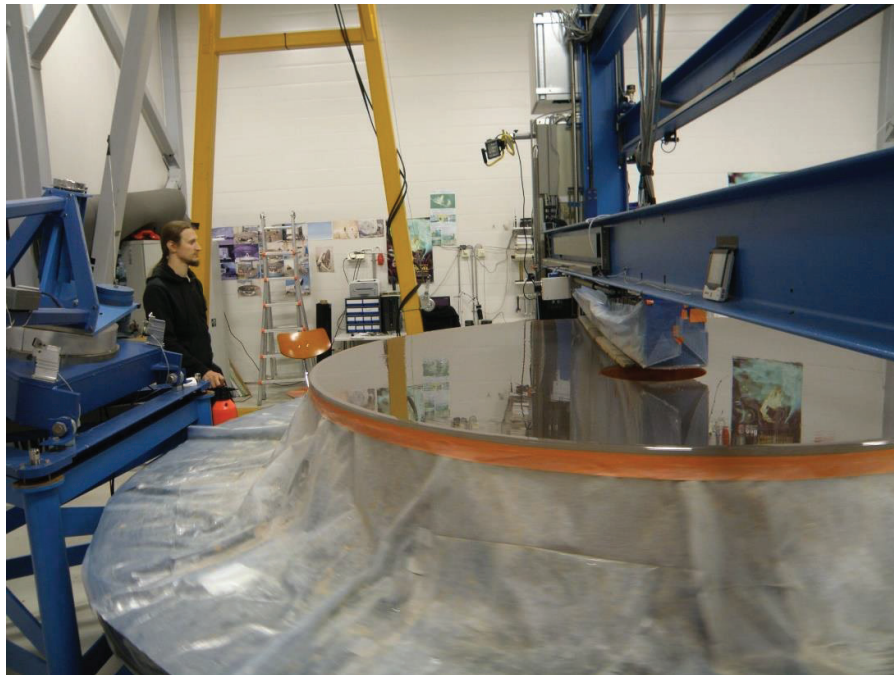

Figure 6. Polishing of the 2.6 m UV collimator at OPTEON Oy.

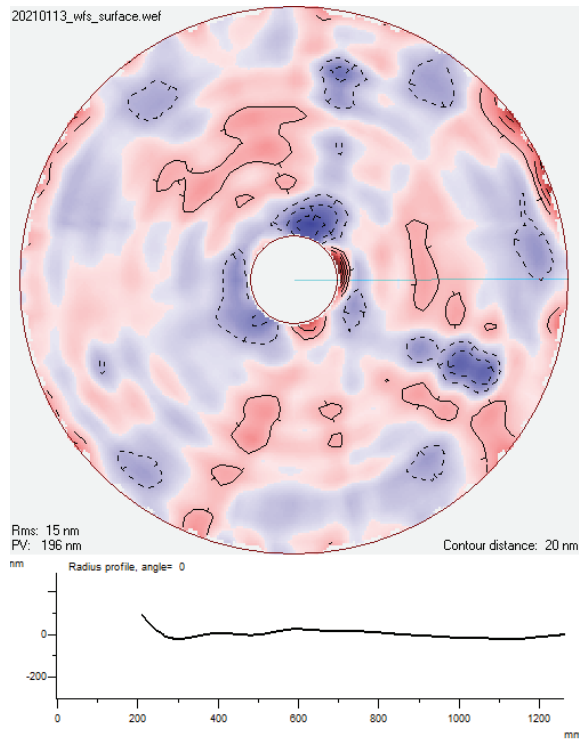

Figure 7. Latest surface accuracy measurement performed at OPTEON.

The current status of the collimator mirror is shown in the error map in Figure 7. The progress of the surface accuracy of the collimator versus time is shown in Figure 8. As of today, the polishing and lapping phase has taken 15 months.

Log RMS for the shape accuracy of the optical surface of the mirror vs time

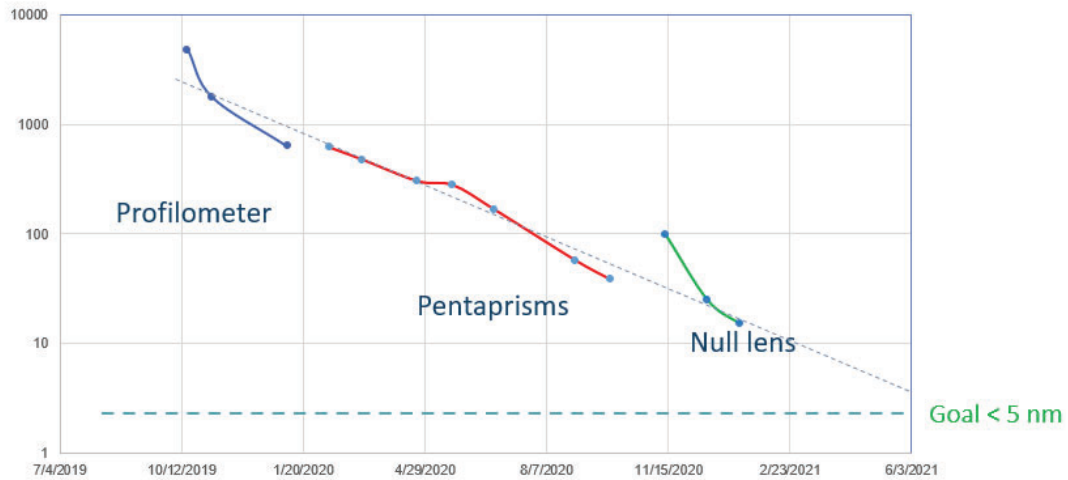

Figure 8. Surface accuracy of the Collimator mirror versus time

4. ATHENA MAM STRUCTURE SUPPORT

The steel structure supporting the ATHENA Mirror Assembly Module (MAM) is fixed to the concrete well slab by means of pre-stressed anchor bolts. It consists in a structure made of standard carbon steel, painted against corrosion.

On top of this structure the ATHENA MAM rests on nine actuators, three fix points and six spring-loaded interfaces. This configuration allows minimizing the gravity deformation.

The Handling and Alignment Device (HAD) system, for the positioning and integration of the Silicon Pore optics Mirror Modules, is mounted on top of the MAM.

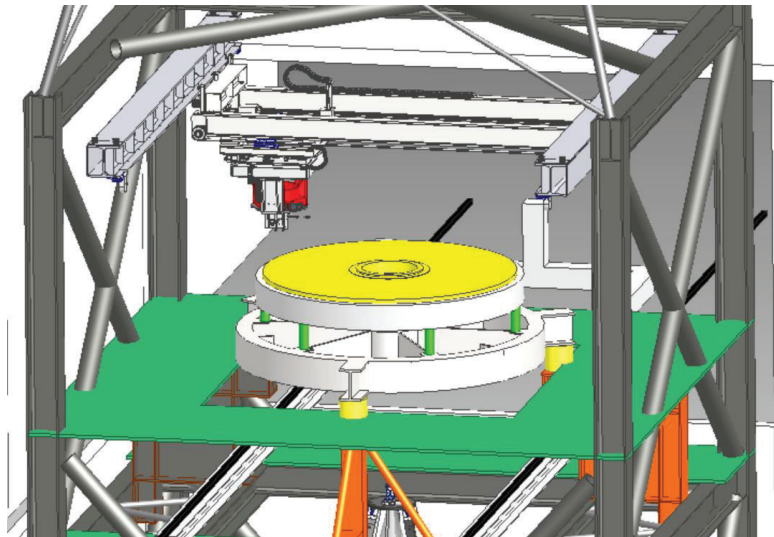

Figure 9. ATHENA MAM structure and Handling and Alignment Device

5. CONCLUSIONS

Media Lario and the team of scientific and industrial partners have developed the process for the alignment and integration of the silicon pore optics mirror modules in the structure of the x-ray ATHENA telescope. The demonstration of the process was done by integrating silicon pore optics mirror modules using an existing optical bench. The UV optical bench (UVOB) for the ATHENA telescope is currently under construction.

The preliminary version of the UVOB is planned to be used in early 2022 for the integration of the Engineering Model (EM) of ATHENA in view of the mission adoption milestone.

ACKNOWLEDGMENT

This work has been done in the framework of the European Space Agency contracts 4000114931/15/NL/HB and 4000126922/19/NL/IB/gg.

REFERENCES

- [1] ESA, "2ATHENA: Assessment of an X-Ray telescope for ESA Cosmic Vision Program," CDF-150(A) (2014).
- [2] <http://www.the-athena-x-ray-observatory.eu>.
- [3] <http://sci.esa.int/cosmic-vision/54517-athena>.

- [4] Collon, M.J., et al., "Development and manufacturing of SPO x-ray mirrors," Proc. SPIE 11119-13, (2019).
- [5] Ayre, M., Bavdaz, M., Ferreira, I., Wille, E., Fransen, S., Stefanescu, A., "ATHENA: phase A study status and optics/instrument," Proc. SPIE 11119-27 (2019).
- [6] <<http://www.mpe.mpg.de/heg/panter>>.
- [7] Burwitz, V., et. al., "PANTER activities toward testing and calibrating ATHENA optics," Proc. SPIE 11119-24, (2019).
- [8] Spiga, D., Collon, D.M., Conconi, P., Valsecchi, G., Wille, E., et al., "Optical simulations for design, alignment, and performance prediction of silicon pore optics for the ATHENA X-ray telescope," Proc. SPIE 10399-16 (2017).
- [9] Valsecchi, G., Marioni, F., Bianucci, G., Zocchi, F.E., Gallieni, D., Parodi, G., Ottolini, M., Collon, D.M., Pareschi, G., Spiga, D., Bavdaz, M., Wille E., et al. "Optical integration of SPO mirror modules in the ATHENA telescope," Proc. SPIE 10399-13 (2017).
- [10] https://www.helmholtz-berlin.de/quellen/bessy/index_en.html.