

Design and Test of Pneumatic Systems for Production Automation

Giorgio Figliolini and Pierluigi Rea

LARM - Laboratory of Robotics and Mechatronics
DiMSAT, University of Cassino
G. Di Biasio, 43 - 03043 Cassino, ITALY
e-mail: figliolini@unicas.it and rea@unicas.it

Abstract

This paper deals with the teaching activity on the design and test of pneumatic and electro-pneumatic systems, which is carried out at the University of Cassino in Italy, since the academic year 1994/95.

In particular, the design and test of a vacuum gripper and an automatic packaging machine, are proposed as examples of components and systems operating in on/off environment.

Likewise, a proportional pressure valve and a robotic automatic packaging are presented as examples of components and systems operating in analogue environment for the production automation.

1. Introduction

Pneumatic and electro-pneumatic components find several applications in the industrial environment, mainly to solve problems of product automation.

Most of the applications are in the field of the low-cost automation because the traditional pneumatic and electro-pneumatic components are conceived to work in on/off environment. In particular, a great development of the electro-pneumatics has been due to the development of the electronics, which has given many other solutions in terms of sensors, controllers and mechatronic devices.

Moreover, the electro-pneumatics is not only on/off, but several analogue components can be found, as proportional valves in pressure or flow, which can be used to design suitable servo-systems with good static and dynamic performances.

Some books dealing with pneumatics and electro-pneumatics can be found in literature, as reported in [1-6], but also a research activity can be found, as in [7-14]. In particular, the design of a biped walking robot with pneumatic actuation was proposed in [7], some electro-pneumatic force control systems for gripper and robotic hands were proposed in [8-10], and the modeling and experimental investigation of electro-pneumatic components were reported in [11-13].

This paper deals with the teaching activity on the design and test of pneumatic and electro-pneumatic systems, which has been carried out within the course of "Regulation and Control of Mechanical Systems" for mechanical engineers at the Faculty of Engineering of the University of Cassino in Italy, since the academic year 1994/95. In addition, according to the reform of the Italian University, the courses of "Fluid Automation" and "Fluid Servo-Systems" have been conceived and activated since the academic year 2003/04 for mechanical engineers at the same Faculty, which are given at last year for undergraduates and graduates, respectively.

Moreover, although after a suitable simplification, the contents of these courses are continuously improved and implemented of new results, which are obtained by a strong theoretical and experimental research activity on these topics, as reported in [7-13].

The course of "Fluid Automation" deals with the fundamentals of the digital pneumatics and electro-pneumatics, since the analysis of components, as actuators, valves and sensors, up to the design and control of automatic systems in on/off environment. All this theoretical teaching activity is supported by a consistent practical activity, which is carried out at LARM (Laboratory of Robotics and Mechatronics) in Cassino because of suitable test-beds. Hard-wired logic systems with pneumatic and relay technologies are designed, assembled and tested, while different automatic cycles are obtained through a suitable programming of PLCs.

In particular, the design and test of a vacuum gripper and an automatic packaging machine, are proposed as examples of components and systems operating in on/off environment.

Likewise, a proportional pressure valve and a robotic automatic packaging are presented as examples of components and systems operating in analogue environment of the production automation.

2. Design and test of a vacuum gripper

Vacuum grippers can be used for mechanical handling and low-cost automation as gripping components during robotic manipulations. Some applications can be found as vacuum egg lifter, high speed labeling machine, vacuum feeding sheet of carton or steel.

The design of vacuum grippers is usually based on the use of ejectors driven by compressed air because they represent a compact and economical solution, which can be obtained through single or multi-ejectors.

A typical ejector is a Venturi pipe between a supply port to the exhaust port, while a third vacuum port is connected to a suction-cup and in particular, to the inner chamber, which is obtained when the suction-cup is in contact with the object to grasp.

The holding force of a suction-cup corresponds usually to the maximum force as the product of the area of the inner sealing lip and the depression inside the chamber. However, a minimum safety factors of 2 for horizontal surfaces and 4 for vertical surfaces is recommended.

In particular, the electro-pneumatic circuit of a vacuum gripper is shown in Fig.1, as composed by

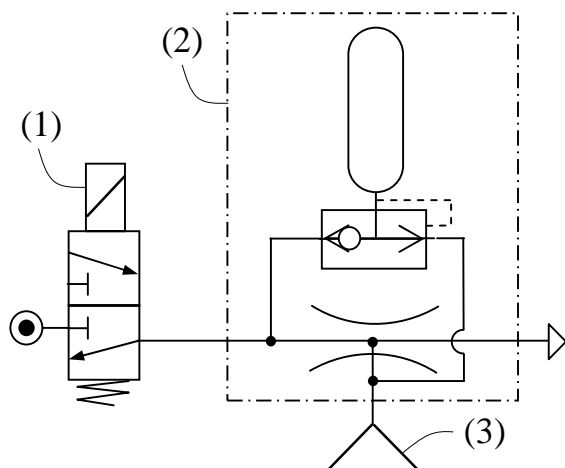

Fig.1 Electro-pneumatic circuit of the vacuum gripper: 1) three-way / two-position solenoid / spring-return valve; 2) ejector with release device; 3) suction-cup

a three-way/two-position solenoid/spring-return valve 1, the ejector 2 that is provided of a suitable release device and a suction-cup 3. The release device lets to apply a positive pressure in the chamber between the suction-cup and the object in order to release it quickly. In this paper, the design and test of the vacuum gripper of Fig.1 is presented through suitable sketches of the pneumatic circuit and results of several experimental tests, which have been carried out at LARM in Cassino. Thus, the flow-rate diagrams of Figs.4 to 6 for the valve of type Metalwork SOV-23-SOS-NC and for the ejector of type Festo VAK ¼ have been determined in agreement with the ISO 6358 [14] by using the experimental test-bed of Fig.2.

In particular, this test-bed is composed by the valve 1 or the pneumatic component to test, the metering pipes 2 and 3 to detect the upstream P_{UP} and downstream P_{DW} pressures, respectively, through the pressure transducers 4 and 5, as displayed also in Fig.3; the adjustable choke valve 6 in order to set the downstream pressure; the flow-meter 7 and the supply operating unit 8 to ensure a constant pressure supply P_s .

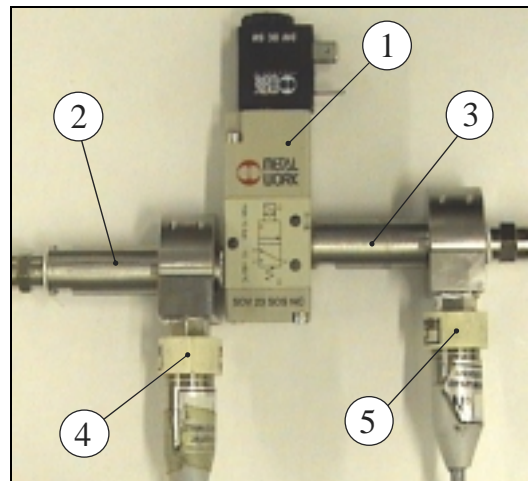

Fig.3 Particular view of the test-bed of Fig.2: 1) test-valve; 2) and 3) tubes for measuring the upstream and downstream pressures; 4) and 5) pressure transducers.

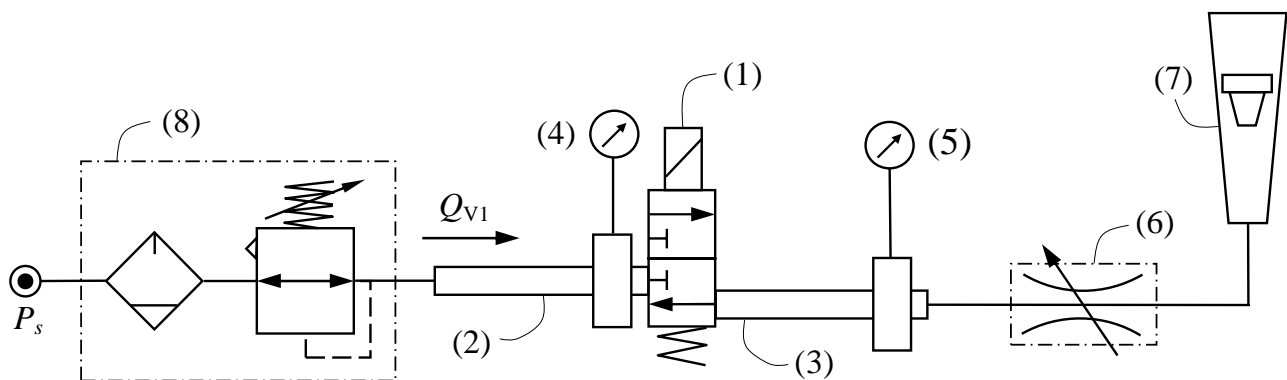

Fig.2 Sketch of the test-bed for measuring the flow-rate across the valve according to the ISO 6358

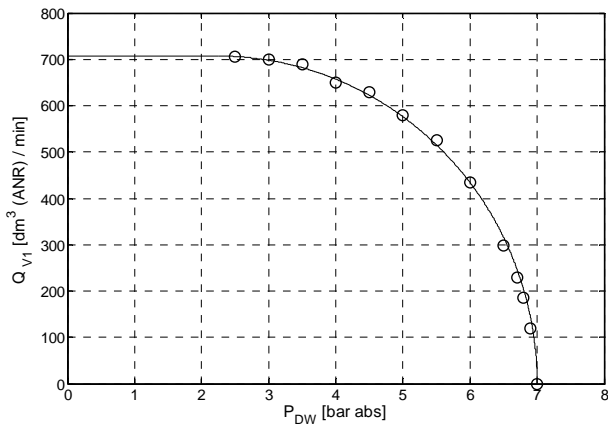

Fig.4 Flow-rate Q_{V1} of the valve from the supply port at pressure $P_S = 7$ bar abs to the outlet port at pressure P_{DW}

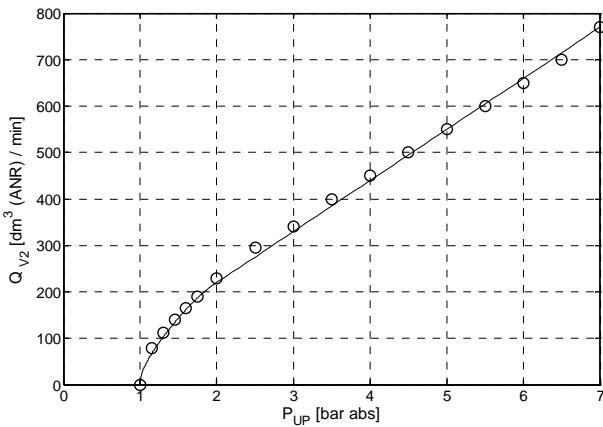

Fig.5 Flow-rate Q_{V2} of the valve from the outlet port at pressure P_{UP} to the exhaust port at pressure $P_0 = 1$ bar abs

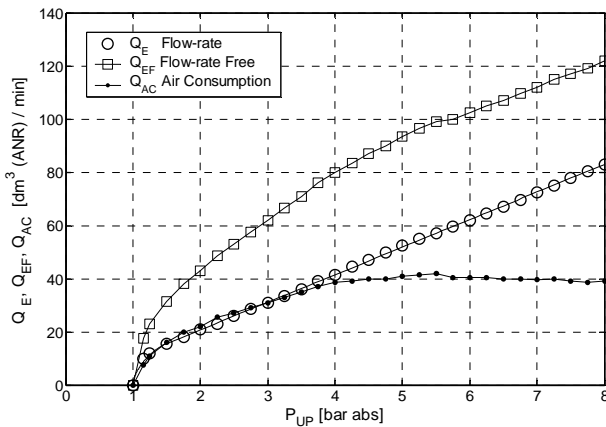

Fig.6 Flow-rate across the ejector of the vacuum gripper: Q_E flow-rate with the vacuum port closed; Q_{EF} flow-rate with the vacuum port free; Q_{AC} air consumption

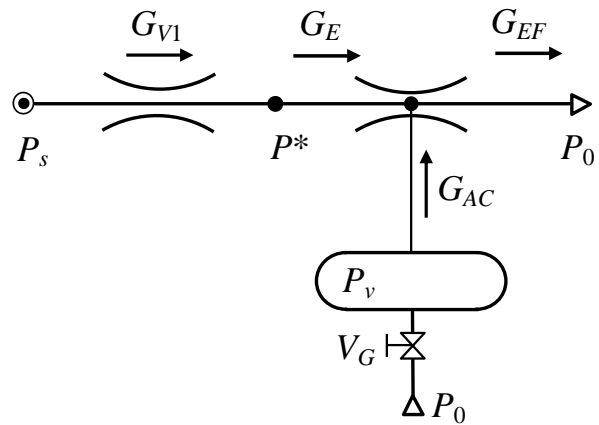

Fig.7 Scheme of the pneumatic circuit of the vacuum gripper when the valve is operated (cut-off valve V_G closed or open sketches the suction-cup in grasp or not)

The flow-rate Q_{V1} across the valve from the supply port at the constant pressure $P_S = 7$ bar abs to the outlet port at pressure P_{DW} is reported in the diagram of Fig.4, while the diagram of the flow-rate Q_{V2} across the valve from the outlet port at pressure P_{UP} to the exhaust port at constant pressure $P_0 = 1$ bar abs is reported in Fig.5. The experimental points are indicated through small circles, while the theoretical flow-rates according to the ISO 6358 are shown in continuous line [14].

Likewise, the flow-rate diagrams of Fig.6 for the ejector have been obtained, where the flow-rate Q_E with the vacuum port closed, the flow-rate Q_{EF} with the vacuum port free have been measured versus the upstream pressure. The air consumption Q_{AC} has been evaluated as difference between Q_{EF} and Q_E .

Figure 7 shows a scheme of the pneumatic circuit for the vacuum gripper, while the Fig.8 shows both diagrams of Q_{V1} from Fig.4 and that of Q_E from Fig.6.

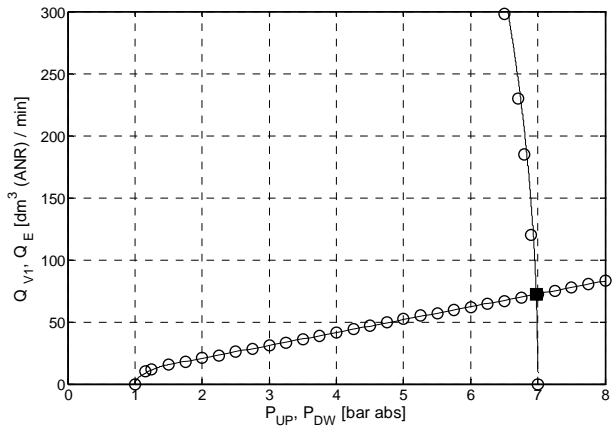

Fig.8 Working point (indicated through a square-marker) of the vacuum gripper with its suction-cup in grasp, as intersection of the curves of Q_{V1} and Q_E by Figs.4 and 6

In particular, the inner restriction between the supply port and the outlet port of the valve is sketched through a pneumatic resistance working between the pressures P_s and P^* . The ejector is sketched through a pneumatic resistance, which is connected with a small tank corresponding to the chamber between the suction-cup and the object in grasp. In this operating condition, the ejector works with three ports at pressures P^* , P_v and P_0 , respectively (the cut-off valve V_G is closed). Instead, when the vacuum port is free (the cut-off valve V_G is open), P_v is equal to P_0 and the flow-rate Q_{EF} is obtained. The cut-off valve V_G is reported in the scheme of Fig.7 just with the aim to consider the case with the object in grasp for V_G closed or not for V_G open.

Moreover, the mass flow-rate G_{V1} across the valve, and the mass flow-rates G_E , G_{EF} and G_{AC} across the ejector, are represented in Fig.7 as related to the volumetric flow-rates Q_{V1} , Q_E , Q_{EF} and Q_{AC} respectively.

Therefore, referring to the Fig.8, the working point of the vacuum gripper that is indicated with a square-marker, has been evaluated by intersecting the flow-rate diagram of Fig.4 for the valve and the flow-rate diagram of Fig.6 for the ejector. This intersection point gives the pressure P^* of Fig.7 and the flow-rate Q^* across the vacuum gripper when the suction-cup is in grasp.

2. On/off automatic packaging

A lay-out of the proposed on/off automatic packaging of bottles of water is shown in Fig.9. The automatic machine is supposed to be provided of six pneumatic cylinders \mathcal{A} , \mathcal{B} , \mathcal{C} , \mathcal{D} , \mathcal{E} and \mathcal{F} in order to perform the automatic packaging through suitable on/off displacements. In particular, it is supposed that each carton box reaches the position in front at the rigid plate, which is attached to the piston rod of the cylinder \mathcal{B} , because of the cylinder \mathcal{F} , while the bottles reach the right position because of the cylinder \mathcal{E} .

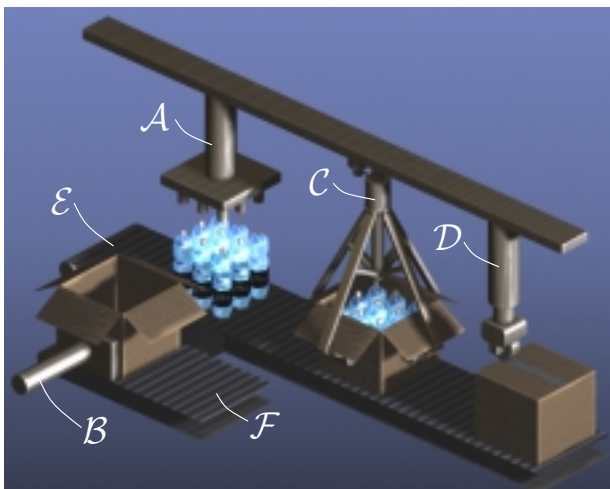

Fig.9 Three-dimensional sketch of the proposed lay-out for the automatic packaging of bottles of water

Cylinder \mathcal{A} is provided of suitable suction-cups in order to grasp nine bottles at same time and put them in the carton box. Cylinder \mathcal{C} actuates a suitable mechanism that allows the closure of the carton box and finally cylinder \mathcal{D} completes the packaging with an adhesive stream, which is attached on the carton by means of a suitable roller.

The electro-pneumatic circuit of the proposed on/off automatic machine is reported in Fig.10, where each double-acting cylinder is operated through a five-way/two-position solenoid-solenoid valve, while twelve Reed are used as end-stroke sensors for the pneumatic cylinders.

The proposed on/off automatic packaging machine works according to the cycle, which is represented in the Grafcet diagram of Fig.11, where the command signals of the pneumatic cylinders are reported for each phase of the automatic cycle under the condition imposed by the feed-back signals that come from the sensor system. Thus, the packaging machine works as an event-based system in on/off environment. In particular, referring to the Grafcet of Fig.11, in the first phase the cylinder \mathcal{D} moves downward by pushing the roller on the box;

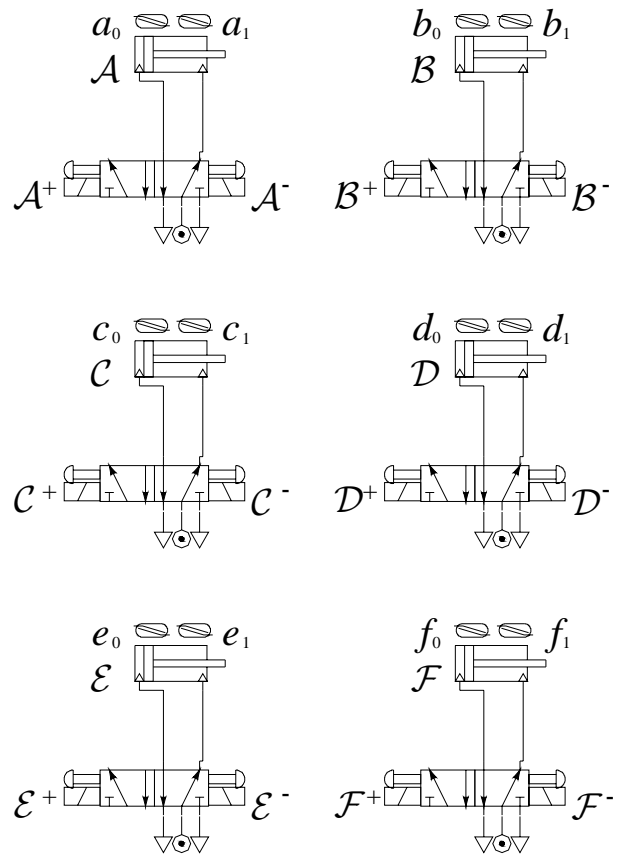

Fig.10 Electro-pneumatic circuit of the automatic machine of Figs.9 and 10

in the second phase, both cylinders \mathcal{F} and \mathcal{E} are moved outstroke, by positioning an open carton box in front at the cylinder \mathcal{B} and nine bottles under the cylinder \mathcal{A} , respectively; in the third phase, cylinder \mathcal{D} is moved upward; in the fourth phase, cylinders \mathcal{E} and \mathcal{F} return at starting instroke position, while \mathcal{A} and \mathcal{C} are moved outstroke, in order to grasp the bottles and the bending parts of the carton box, respectively; in the fifth phase, \mathcal{A} and \mathcal{C} move upward by lifting the bottles and closing the carton box, respectively; in the sixth phase, cylinder \mathcal{B} makes the positioning of the empty carton box; in the seventh phase, cylinder \mathcal{A} makes the packaging of the bottles in the carton box, while \mathcal{B} moves instroke; finally, cylinder \mathcal{A} moves upward to start a new loop.

This automatic cycle has been programmed in Ladder, as reported in Fig.12, and implemented in a PLC controller of type Festo FPC 404 in order to test the proposed on/off automatic packaging on the test-bed of Fig.14.

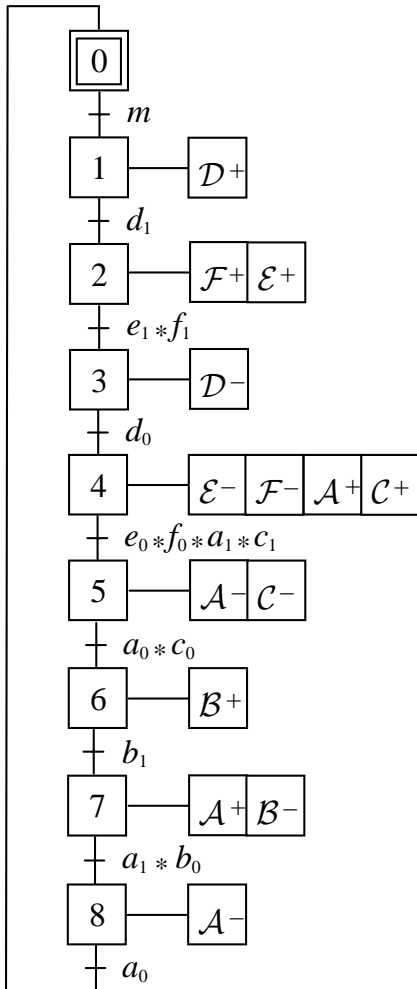

Fig.11 Grafcet diagram for the automatic packaging

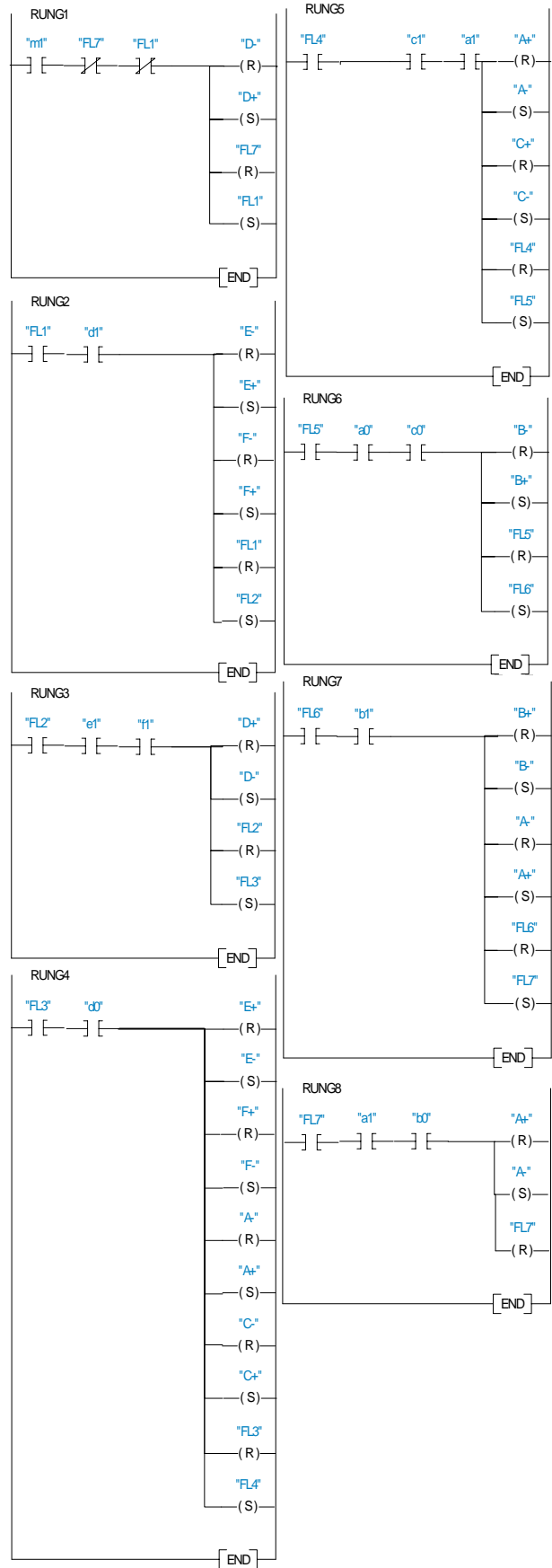

Fig.12 Ladder-diagram for the automatic packaging

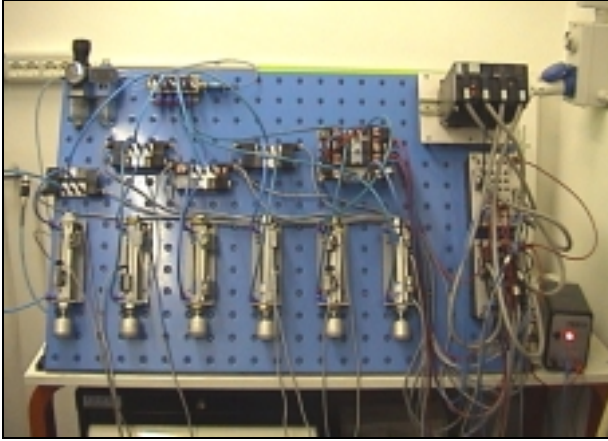

Fig.13 Test of the electro-pneumatic circuit of Fig.10 for the automatic packaging of bottles of water

4. Experimental analysis of a pressure proportional valve

A three-way pneumatic pressure proportional valve with double plunger and a command block that is composed by a pair of modulated digital valves is analyzed and experimentally tested. A section of the valve of type Lucifer EPP3 J-21-U-100-10, actually Parker P3P-R, is shown in Fig.14, while the electro-pneumatic circuit of its internal mechatronic devices is shown in Fig.15.

In particular, the actuation system is composed by the plungers 1 and 2, which can connect the supply port S to the outlet port C , or S to the vent port V . At the rest condition of Fig.14, the valve is closed because the spring pushes upward both plungers by closing the supply port S . Moreover, the controlling pressure inside the servo-chamber keeps both plungers in contact by closing the connection of the outlet port C with the vent port V . Thus, the outlet pressure can be kept at the set value and some disturbance is detected by the internal pressure sensor in order to inform the electronic controller to compensate the disturbance. In fact, because of a disturbance or because of a changing of the electric reference signal V_{REF} , the outlet pressure P_C is changed consequentially. When the pressure P_C has to increase, both plungers are moved downward against the spring by connecting S to C , while when P_C has to decrease, the lower plunger is pushed by the spring against the valve body and the upper plunger is moved upward by connecting C to V .

Thus, the positioning of the plungers is mainly given by the equilibrium between the resulting force of the absolute control pressure, within the servo-chamber, and that due to P_C . In particular, the pressure inside the servo-chamber is controlled by means of two 2/2 (two-way/two-position) valves V_1 and V_2 , which are installed in supply and discharge, respectively, in order to obtain an equivalent three-way proportional flow valve.

The closed-loop control of the pressure is carried out through a suitable electronic board that is situated in the internal upper part of the valve (not shown in Fig.14).

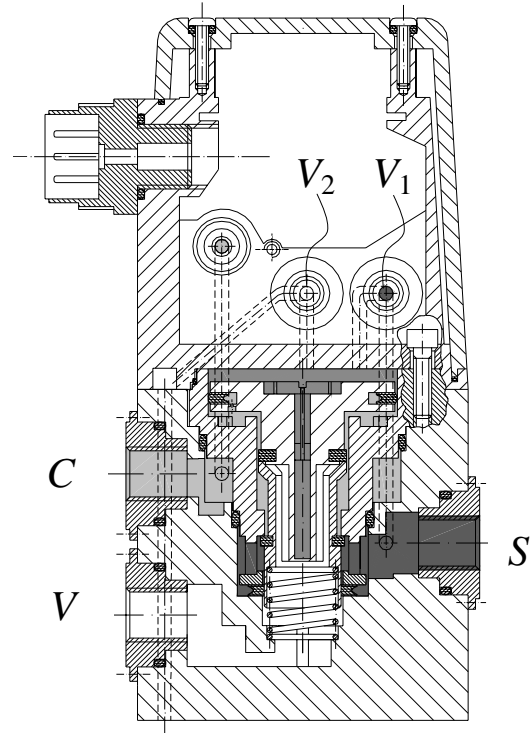

Fig.14 Section of the proportional valve, type Lucifer Honeywell EPP3 J 21 U 100 10, actually Parker P3P-R

An experimental analysis of this pressure proportional valve has been carried out in order to determine its static and dynamic performances.

The static characteristic curve of Fig.16 has been determined between the electric reference signal V_{REF} and the outlet pressure P_C . A static gain $K_V = 0.99917$ bar rel / V has been evaluated.

The experimental frequency response has been analyzed and represented in the Bode diagrams of Figs.17 and 18. The experimental points are indicated through small circles in the diagrams of Figs.16 to 18.

The frequency response in the time domain can be analyzed by referring to the diagrams of Figs.19 to 21.

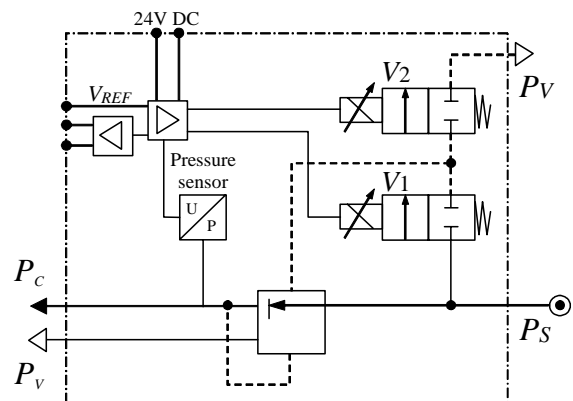

Fig.15 Electro-pneumatic circuit of the valve by taking into account its internal mechatronic devices

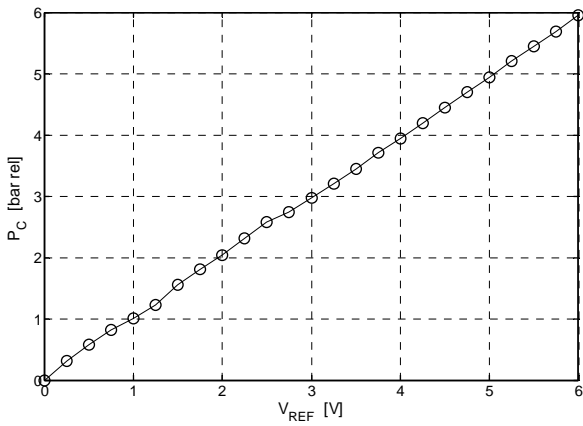

Fig.16 Static characteristic curve between the V_{REF} voltage input signal and the outlet pressure P_C (static gain of the valve $K_V = 0.99917$ bar rel / V)

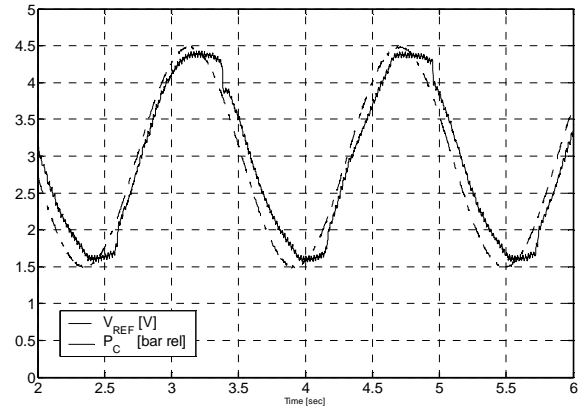

Fig.19 Frequency response in the time domain for a sinusoidal input signal with $V_A = 3$ V, $A = 1.5$ V and frequency $f = 0.6$ Hz

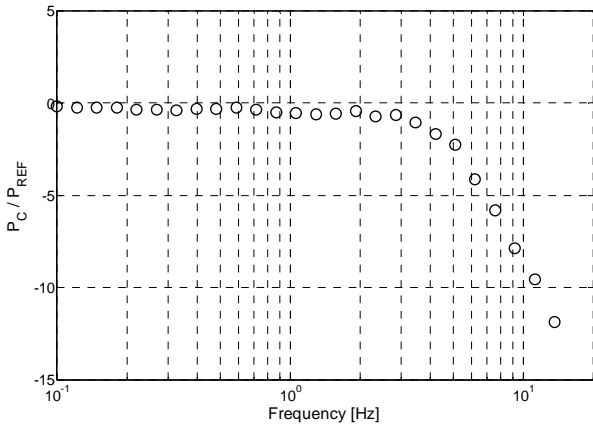

Fig.17 Bode diagram (module) of the valve for a sinusoidal input signal V_{REF} with average value $V_A = 3$ V and amplitude $A = 1.5$ V

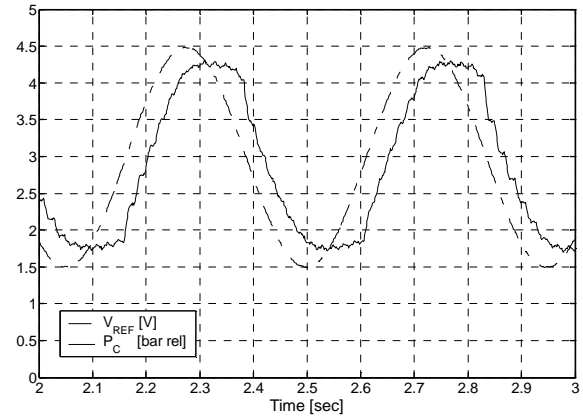

Fig.20 Frequency response in the time domain for a sinusoidal input signal with $V_A = 3$ V, $A = 1.5$ V and frequency $f = 2.2$ Hz

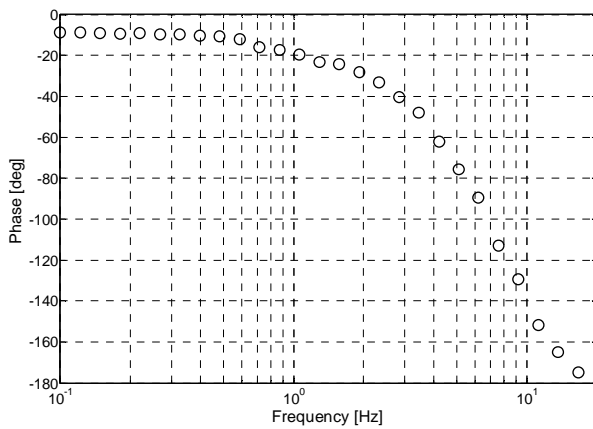

Fig.18 Bode diagram (phase) of the valve for a sinusoidal input signal V_{REF} with average value $V_A = 3$ V and amplitude $A = 1.5$ V

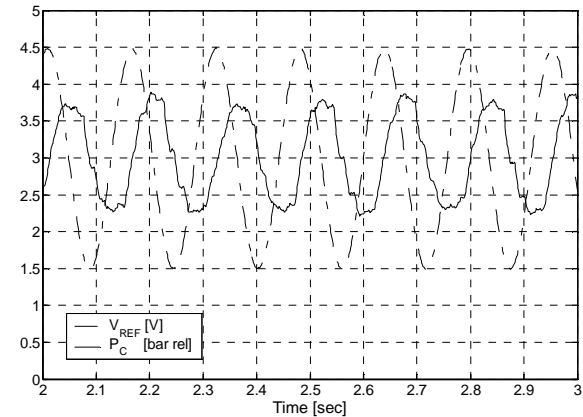

Fig.21 Frequency response in the time domain for a sinusoidal input signal with $V_A = 3$ V, $A = 1.5$ V and frequency $f = 7.95$ Hz

5. Robotic automatic packaging

An multilayer automatic packaging of cylindrical products in group of four for each layer has been considered in order to analyze the performances of a Cartesian robot with pneumatic actuation and electronic control. Moreover, a suitable programming in Ladder of the PLC controller has been carried out and tested for controlling a part of the system in on/off environment and a part in continue mode.

Thus, supposing a packaging with four layers, which are different alternatively, where each one is composed by four equal products, a possible lay-out is shown in Fig.22. Two different kinds of cylindrical products, which are sketched in white and grey colors in Fig.22, are supposed to be positioned along two different lines in the working area of a Cartesian robot. Thus, a typical operation of pick and place from the supplying line to a square packaging box has to be performed by taking into account that four different layers with group of four products are required.

The Cartesian robot allows displacements of the end-effector within a working area of 60000 mm² since the maximum displacement along the X-axis is 200 mm and that along the Y-axis is 300 mm.

Instead, the vertical displacements of the end-effector are carried out in on/off environment, which simplifies the programming and the control, but gives some limitation in the performances of the robot. However, these difficulties have been overcome by using an end-effector, which is provided of a suitable auto-adaptability for reaching different vertical positions, even if the actuator is operated in on/off environment. A solution that seems to be appropriate for this application has been a suction-cup with vertical auto-adaptability.

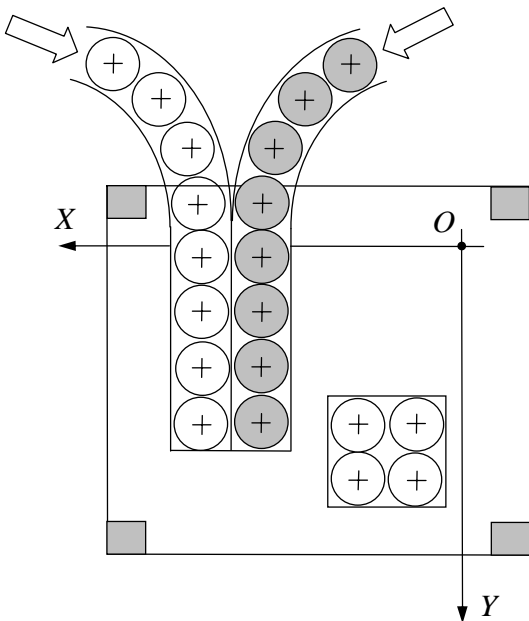

Fig.22 Lay-out for the automatic packaging

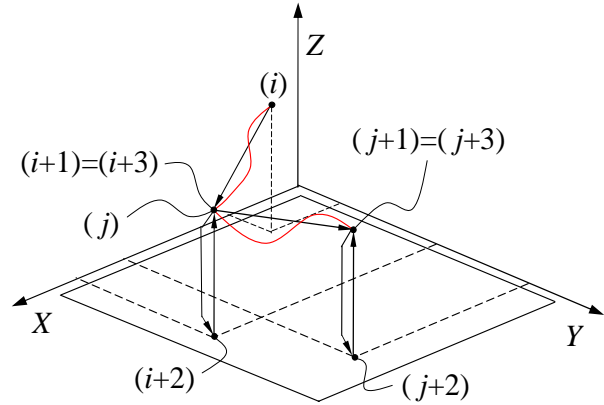

Fig.23 Sketch of the pick and place operation performed by the Cartesian robot

The programming of the Cartesian robot has been carried out by sketching and analyzing in depth the pick and place operation, as reported in Fig.23. In particular, the pick operation starts from the position (i) to (i+1), and then to (i+2) in order to finish in (i+3) that coincides with (i+1). Likewise, the place operation starts from the (j) position to (j+1), and then to (j+2) in order to finish in (j+3) that coincides with (j+1). This sketching has been used to program the PLC controller as reported in Fig.24. Moreover, the programming has been carried out by considering that a part of the electro-pneumatic system operates in on/off environment and a part operates as a pneumatic servo-system.

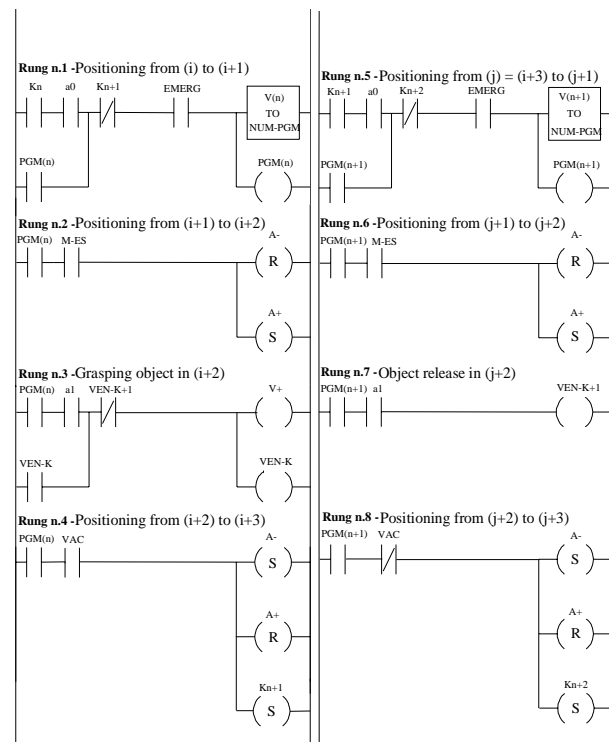

Fig.24 Ladder diagram program to perform the pick and place operation of the Cartesian robot

The actuation of the Cartesian robot for obtaining the displacements along the X, Y and Z-axes is performed by three double-acting pneumatic cylinders. The electro-pneumatic circuit of Fig.25 is composed by Festo components: the rod-less pneumatic cylinders 1 and 2 of type 25-200 and 25-300, respectively, where each one is operated through a flow proportional valve of type MPYE-5-1/8; the pneumatic cylinder 3 of type DGLL-25-160 with magnetic piston and double piston rod, which is operated by the solenoid-solenoid valve of type JMYH-5/2-M5; the vacuum gripper 4 as composed by a suction-cup of type SMC with diameter 25 mm and maximum compression of 50 mm, which is actuated by the ejector of type VAD-1/8 and operated by the solenoid / spring-return valve of type MFH-3/2-M5. Moreover, two check-choke valves of type GRLZ-1/8 allows a manual speed regulation of the cylinder 3. Both end-stroke positions of the cylinder 3 are detected through the Reed sensors a_0 and a_1 , while the displacements along the X and Y-axes of the cylinders 1 and 2 are detected by means of two linear potentiometer position sensors. Finally, the vacuum inside the chamber between the suction-cup and the object to manipulate is detected through a vacuum switch sensor.

The control of the Cartesian robot is performed in a mix environment because both cylinders 1 and 2 are controlled in continue mode through two Festo UCC 100 controllers in order to obtain a suitable positioning of the vacuum gripper in the plane XY, while the cylinder 3 and the vacuum gripper 4 are controlled in on/off mode by means of a PLC (Programmable-Logic-Controller), which also performs a suitable supervision of the whole manipulation. The PLC is connected through a serial port RS-232 with a common PC in order to implement suitable programs to perform several flexible packaging. In particular, the ladder-diagram of Fig.24 has been implemented in the PLC controller in order to test the pick and place operation of the Cartesian robot displayed in Fig.26. Thus, supposing that two different kinds of small plastic discs have to be packaged in a square box through a multilayer positioning, as sketched in the layout of Fig.22, a suitable test-bed has been built at LARM (Laboratory of Robotics and Mechatronics) in Cassino. The multilayer positioning has been possible because of the particular adaptability of the suction-cup, even if the pneumatic cylinder 3 is operated in on/off environment by reaching the same end-stroke positions. The experimental tests have given good performances.

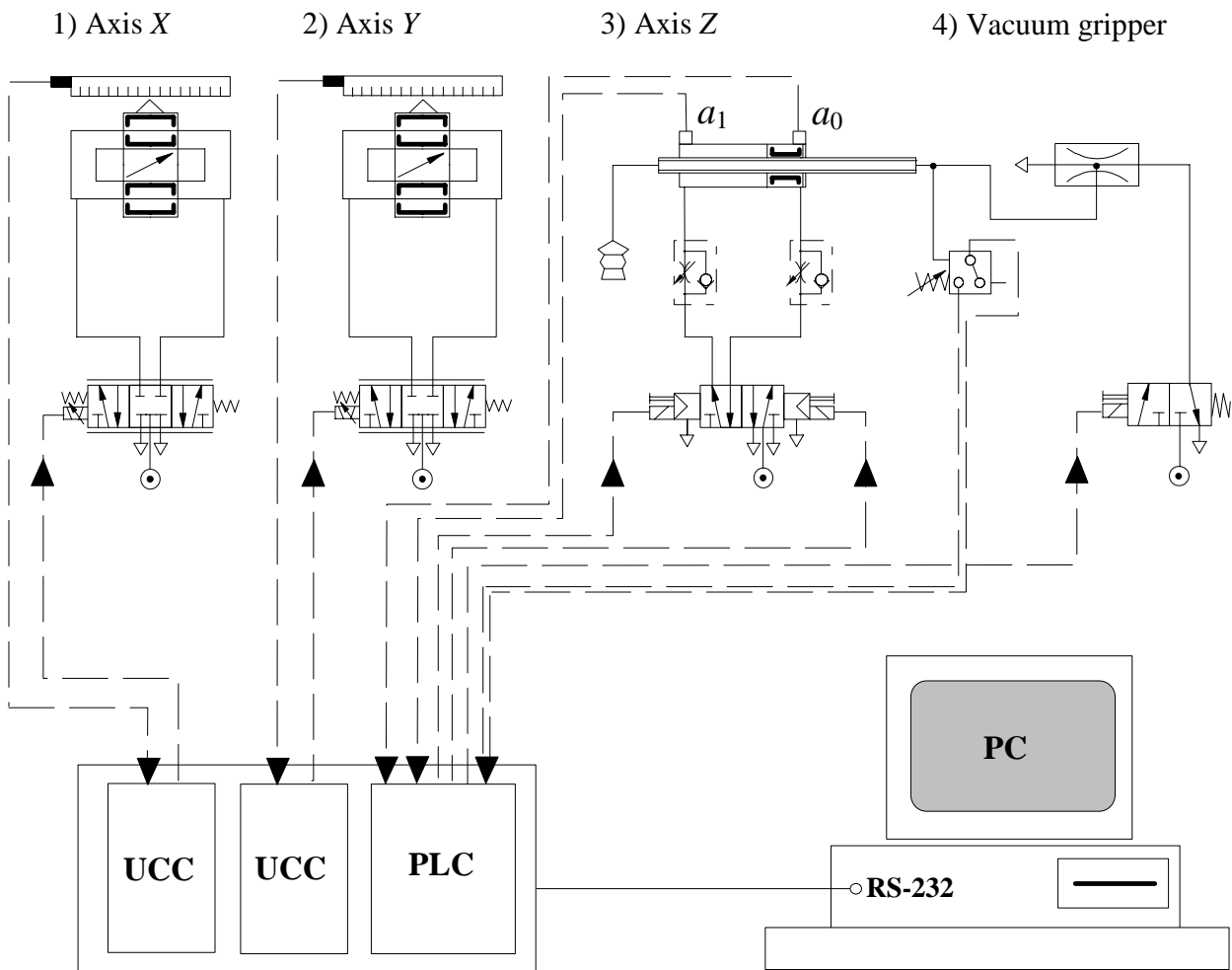

Fig.25 Electro-pneumatic circuit of the three-axes Cartesian robot

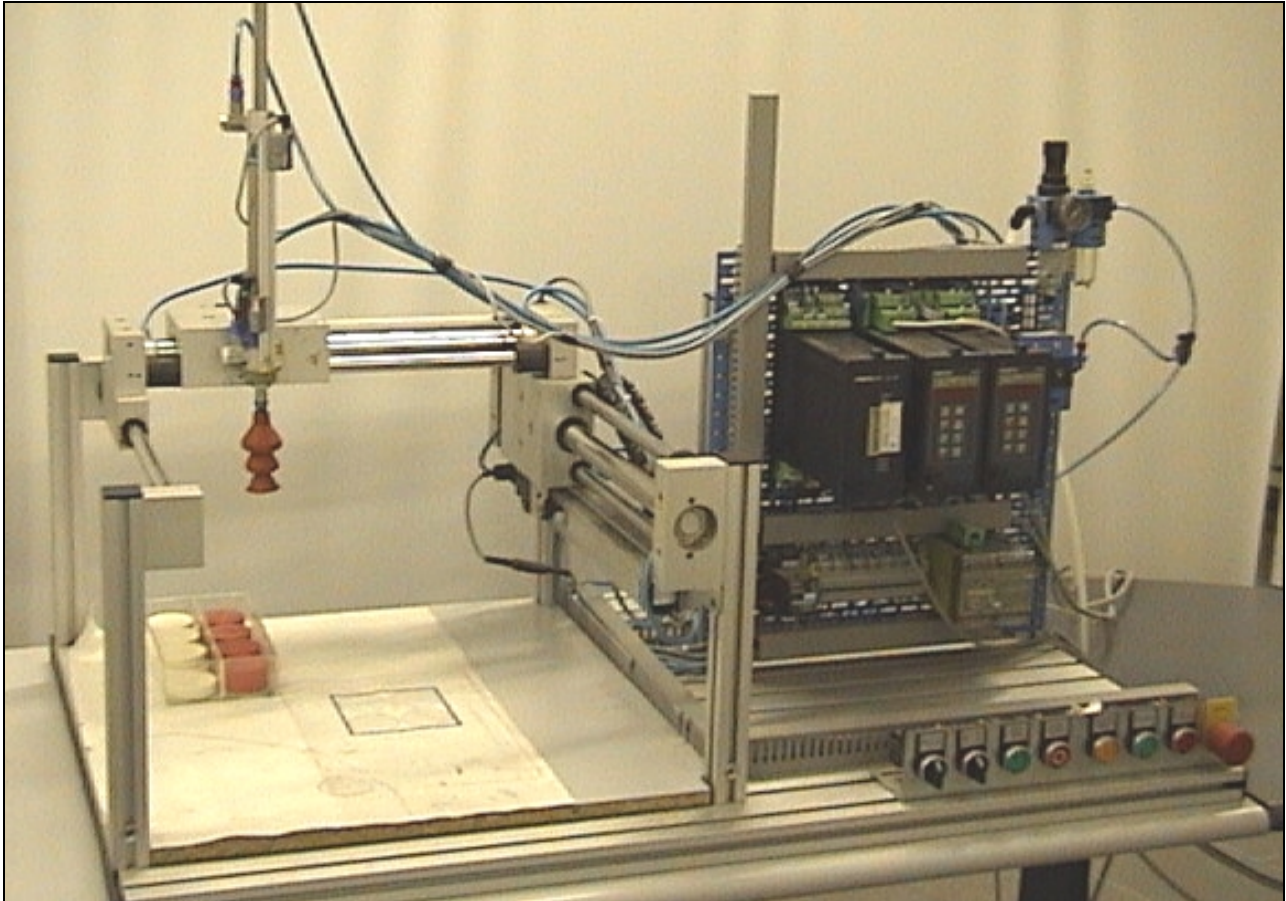

Fig.26 View of the three-axes Cartesian robot with pneumatic actuation and programmable electronic control, which has been used for testing the automatic packaging sketched in the lay-out of Fig.22

6. Conclusions

The design and test of several kinds of pneumatic systems for production automation have been presented. This activity has been developed in the courses dealing with pneumatics at the University of Cassino.

In particular, a vacuum gripper and an on/off automatic packaging have been considered for what concerns on/off systems, while a proportional pressure valve and a robotic automatic packaging have been analyzed for what concerns the analogue systems.

7. References

1. Balla R., 1991. *Electro - Pneumatics*, Mannesman Rexroth Pneumatik GmbH, Hannover.
2. Belforte G., Manuello Bertetto A., Mazza L., 2003. *Pneumatics*, Tecniche Nuove, Milan. (in italian)
3. Deppert W., Stoll K., 1988. *Cutting Costs with Pneumatics*, Vogel - Buchverlag, Würzburg.
4. Fleischer H., 1995. *Manual of Pneumatic Systems Optimization*, McGraw Hill, New York.
5. Hasebrink B.J., 1991. *Basic Pneumatics*, Mannesman Rexroth Pneumatik GmbH, Hannover.
6. Wojtecki R., 1999. *Air Logic Control for Automated Systems*, CRC Press, New York.
7. Figliolini G., Ceccarelli M., "Walking programming for an electropneumatic biped robot", *Mechatronics*, 1999, **9**, pp.941-964.
8. Figliolini G., Sorli M., "Open-loop force control of a three-finger gripper through PWM modulated pneumatic digital valves", *Journal of Robotics and Mechatronics*, 2000, **12** (4), pp.480-493.
9. Figliolini G., "A force control system for grippers with pneumatic actuation", *10th RAAD Workshop on Robotics in Alpe-Adria-Danube Region*, Wien, 2001, paper RD-9.
10. Rea P., Figliolini G., "Actuation force control of Ca.U.M.Ha. robotic hand through PWM modulated pneumatic digital valves", *PhD Symposium - 3rd Fluid Power Net International*, Terrassa, 2004.
11. Figliolini G., Sorli M., "Experimental investigation on a proportional flow valve", *Seventh Triennial International Symposium on Fluid Control, Measurement and Visualization*, Sorrento, 2003, paper n.169.
12. Sorli M., Figliolini G., Pastorelli S., "Dynamic model and experimental investigation of a pneumatic proportional pressure valve", *IEEE/ASME Transactions on Mechatronics*, 2004, **9** (1), pp.78-86.
13. Sorli M., Figliolini G., Pastorelli S., "Modeling and experimental validation of a two-way pneumatic digital valve", *Bath Workshop on Power Transmission & Motion Control*, Eds. C.R. Barrows and K.A. Edge, Professional Engineering Publishing, London, 2003, pp.291-305.
14. ISO 6358, *Pneumatic Fluid Power Components Using Compressible Fluids, Determination of Flow-rate Characteristics*, 1992.