

## Design of Smoke Detector for Smart Room Based on Arduino Uno

Dirja Nur Ilham<sup>1\*</sup>, Rudi Arif Candra<sup>2</sup>, Muhammed Saat Talib<sup>3</sup>, Mario di Nardo<sup>4</sup>, Khusnul Azima<sup>5</sup>

<sup>1,2</sup>Politeknik Aceh Selatan, Indonesia, <sup>3</sup>University of Babylon, Iraq, <sup>4</sup>Universita degli Studi di Napoli, Italy, <sup>5</sup>STIT-HAFAS Subulussalam, Indonesia

<sup>1</sup>[dirja.poltas@gmail.com](mailto:dirja.poltas@gmail.com), <sup>2</sup>[rudiarifcandra@gmail.com](mailto:rudiarifcandra@gmail.com), <sup>3</sup>[mohammed90.saad1@gmail.com](mailto:mohammed90.saad1@gmail.com), <sup>4</sup>[mario.dinardo@unina.it](mailto:mario.dinardo@unina.it),

<sup>5</sup>[khusnulzimex@gmail.com](mailto:khusnulzimex@gmail.com)



### \*Corresponding Author

#### Article History:

Submitted: 09-01-2021

Accepted: 09-04-2021

Published: 09-05-2021

#### Keywords:

MQ2; Arduino Uno; Smoke; Smart room.

#### Brilliance: International Journal of Artificial

Intelligence is licensed under a Creative Commons Attribution-NonCommercial 4.0 International (CC BY-NC 4.0).

### ABSTRACT

Smoke is one of the air pollutions that is very detrimental to the health of both the smoker himself and others around him. Inhaling other people's smoke is even more dangerous than inhaling your own smoke. Even the dangers that must be borne by passive smokers are three times greater than the dangers of active smokers. Smoke is also very detrimental to the health of patients in hospitals, especially patients who suffer from asthma. For people with asthma who have problems in the respiratory tract, asthma can recur at any time due to inhaling smoke. This research will develop a smart room that can detect smoke to maintain and protect the room from smoke that interferes with health. The tool to be developed uses an MQ2 sensor, LCD, exhaust fan, buzzer, and Arduino Uno microcontroller. Where an MQ2 sensor is needed to detect smoke around it, an LCD is needed to display the percentage of smoke, a microcontroller as a controller for all components, a buzzer is used as an alarm when the smoke level in the room is unhealthy, and the exhaust fan functions as a sucker for dirty air so that the smoke level in the room can be reduced.

### INTRODUCTION

Air is one of the sources of human life that can be obtained freely. Good and bad air quality can affect human health and activities. Clean air can cause a person to feel comfortable in a certain place so that they can do activities well and have fun. On the other hand, poor air quality due to pollution can actually interfere with life activities because it is polluted with various kinds of toxic substances originating from natural pollution, vehicle pollution, and cigarette smoke pollution that are harmful to human health.

Cigarette smoke is one of the air pollutions. Inhaling other people's cigarette smoke is more dangerous than smoking your own cigarette. Even the dangers that must be borne by passive smokers are three times that of active smokers. Cigarette smoke is also very detrimental to the health of patients in hospitals, especially patients suffering from asthma. For people with asthma who experience problems in their airways, their asthma can relapse from time to time because of inhaling cigarette smoke. And from previous studies that discuss the detection of cigarette smoke, there are quite a number of them, including a cigarette detection system in a closed room based on the Internet of Things (IoT) (Sulistyowati, Findawati, Ayubi, Jamaaluddin, & Sulistyanto, 2019). Design of a cigarette smoke detection system using an Arduino-Based Short Message Service (SMS) Alert (Mandarani et al., 2016) and (Utomo & Saputra, 2016). Design of the Multiple Warning system for detecting cigarette smoke using an Arduino-based MQ-135 sensor (Gustavia & Nurraharjo, 2018). Design and build an alarm for detection of cigarette smoke and noise in the classroom automatically based on a microcontroller (Ratnasari, 2018). Design of a smoke detector in a smoking room using an MQ-2 sensor with an Atmega328 microcontroller (Rahmadani, 2018). Sensor, microcontroller, and IoT based smoke and fire detection system design (Waworundeng, 2020). Design and build a detector and neutralizer of indoor cigarette smoke using the Arduino-based PI (Propositional Integral) method (Rahmat, Somawirata, & Nasional, 2018). Design and build a smoke and flame detector for health and fire prevention based on Arduino Uno and GSM Sim900A (Hamdani, Handayani, & Risdianto, 2019). The application of the internet of things has also been carried out for heart rate monitoring (Ilham, Hardisal, Balkhaya, Candra, & Sipahutar, 2019). also applied to light control using social media applications (Rudi Arif Candra, Ilham, Hardisal, & Sriwahyuni, 2019). Control the infusion run out with Arduino Uno with social media apps (Rudi Arif Candra, Saputra, Ilham, Setiawan, & Hardisal, 2020). Designing an Arduino-based Automatic Cocoa Fermentation Tool (Ilham, Balkhaya, Candra, Hardisal, & Hasbaini, 2020). control the water pump on traditional boats automatically (Ihsan, Ilham, Candra, Yunan, & Hardisal, 2020). Rain monitoring system for nutmeg drying based on internet of things (Ilham, Satria, Anugreni, Candra, & Kusumo, 2021). Amplitude range data validation in the Internet of Things (IoT) sensor (R. A. Candra, Suherman, & Ilham, 2021).

From the above background, this research will design a healthy smart room from Arduino Uno-based cigarette

smoke by using the application of the MQ 2 sensor and displaying the percentage of smoke and also based on warning and neutralizing smoke in the room.

### LITERATURE REVIEW

There were many previous studies that discussed smoke detection, there are quite a number of them, including a cigarette detection system in a closed room based on the Internet of Things (IoT) (Sulistiyowati et al., 2019). Design of a cigarette smoke detection system using an Arduino-Based Short Message Service (SMS) Alert (Mandarani et al., 2016) and (Utomo & Saputra, 2016). Design of the Multiple Warning system for detecting cigarette smoke using an Arduino-based MQ-135 sensor (Gustavia & Nurraharjo, 2018). Design and build an alarm for detection of cigarette smoke and noise in the classroom automatically based on a microcontroller (Ratnasari, 2018). Design of a smoke detector in a smoking room using an MQ-2 sensor with an Atmega328 microcontroller (Rahmadani, 2018). Sensor, microcontroller, and IoT based smoke and fire detection system design (Waworundeng, 2020). Design and build a detector and neutralizer of indoor cigarette smoke using the Arduino-based PI (Propositional Integral) method (Rahmat et al., 2018). Design and build a smoke and flame detector for health and fire prevention based on Arduino Uno and GSM Sim900A (Hamdani et al., 2019).

### METHOD

The tools and materials we use in designing a CO<sub>2</sub> level detector in a smoke-free room consist of hardware and software, including:

#### Hardware

The hardware used includes:

- A computer with a minimum specification of Dual Core Ram 2Gb works as a place to run Arduino Applications
- Minimum Arduino Uno Microcontroller System is the main minimum board in running the Arduino Uno microcontroller
- 16x2 LCD as a tool to display the result of reading the percentage value of CO<sub>2</sub> gas content
- Buzzer as a tool to make sound
- Relay as regulator On/Off Cooling Fan
- MQ2 sensor as a CO<sub>2</sub> gas detection sensor
- Power Supply 9 V as a microcontroller and relay power supply

#### Software

The software used in this research are:

- Windows 7 Ultimate 32 Bit: The operating system used to run all the software on the computer
- Arduino IDE 1.8.2: a software used in developing microcontroller applications starting from writing source programs, compiling, uploading, and testing terminals.
- Fritzing 0.9.3b.pc: open-source software that can be used to design electronic circuits
- Microsoft Visio 2007: a computer application program used to create diagrams, flowcharts, and network schematics.
- Proteus 8 Professional: software for PCB design with PSpice simulation at the schematic level.

#### System planning

This design is made to simplify the process of designing a CO<sub>2</sub> level detector in a smoke-free room. The series of tools is shown in Figure 1.

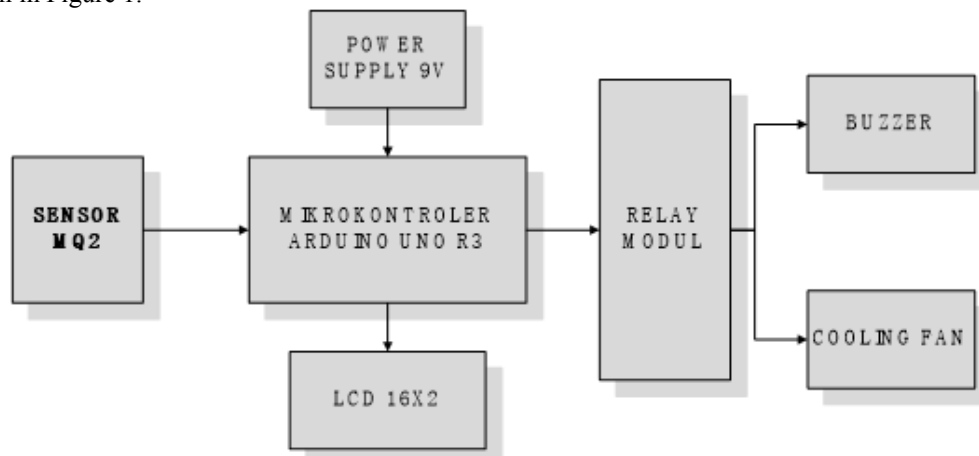

Figure 1. System Design

#### Tool Working Principle

The following is a flowchart of how the CO2 level detection tool works. In Figure 2 there is a series of Flowchart programs for detecting CO2 levels in a smoke-free room where the program starts from the beginning then the source will be installed with an MQ2 sensor, a program that will detect CO2 levels if it is more than 20% then the fan and alarm will turn on.

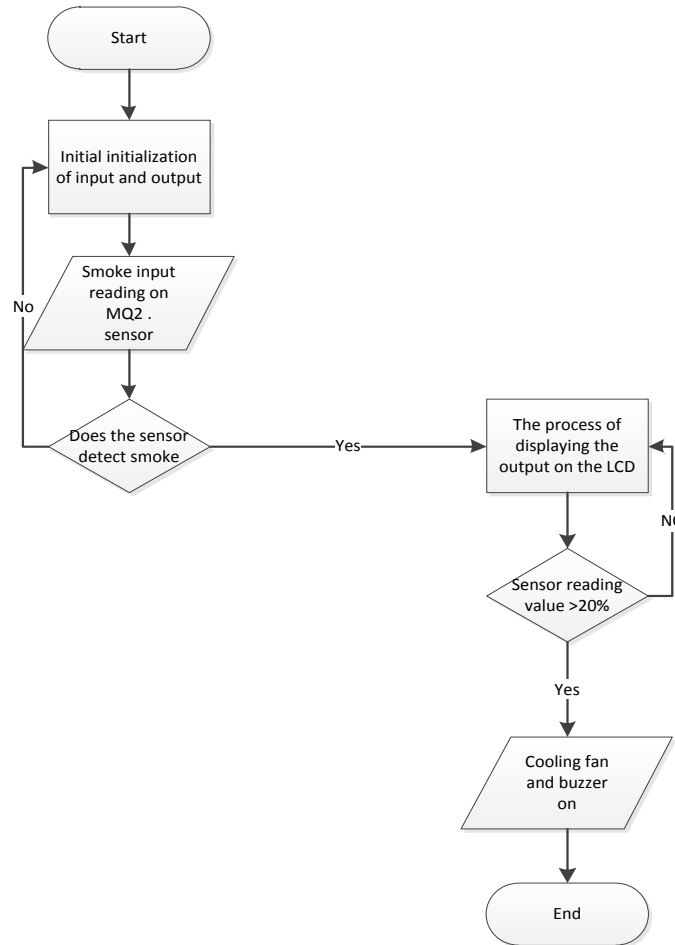

Figure 2. The working principle of the tool

**Set of tools**

By using the Fritzing application, the following tool design is obtained, this co2 level detector works based on input from the MQ2 sensor which will read the co2 level, then the HX711 module will process the data, then be notified to NodeMCUESP8266 and controlled by Arduino, which then Node MCU instructs the fan and buzzer to live.

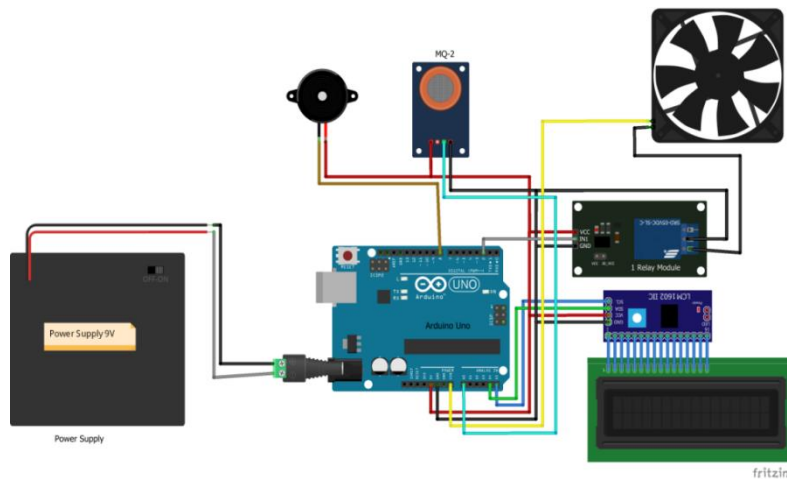

Figure 3. Schematic of the Tool

Tool Construction and Circuit explanation According to the tool design in Figure 3 are as follows:

Table 1. Tool specifications

Component name	Specification	Number of units
Power Supply	9V	1
Sensor	Mq2	1
Buzzer	5v	1
Arduino	Uno R3	1
Relay Modul	12V	1
LCD	LCM 1602 IIc	1
Cooling Fan	Fan	1
Kabel Jumper	Male to female	12

When the voltage source is given, the power supply is on, the power supply provides a voltage of 9V to the relay, where the relay has 2 voltages, to activate the buzzer it takes 5 volts of power and to activate the Cooling Fan uses 5 volts of power too. The Mq2 sensor has been connected to the Arduino Uno Microcontroller and will activate when it detects smoke and the LCD will display the value to be detected, in the form of a percentage.

## RESULT

### Hardware implementation

Hardware implementation for making prototypes is using one MQ-2 sensor, Arduino Uno, and Cooling Fan, assembled using a breadboard, for voltage divider using 5V Relay, 5v buzzer, while LCD to Arduino output to read the content value as soon as possible in the test process try.



Figure 4. Hardware Implementation

### Sensor Test

The MQ-2 smoke sensor circuit can be directly adjusted for sensitivity by turning the trim pot. This sensor is commonly used to detect gas leaks both at home and in the gas industry. The following table shows the measurement results of the MQ-2 sensor using an Analog Multimeter:

Table 2. Calculation of Voltage with Analog Multimeter

No. Sensor Room MQ-2	Sensor Voltage When There is Smoke	MQ-2 Sensor Voltage When There is Smoke
MQ-2 Sensor In Room 1	4.1 Volts	4.2 - 4.4 Volt
MQ-2 Sensor In Room 2	4.1 Volts	4.2 - 4.4 Volt

### Tool Testing and Implementation

In this experiment, the author conducted testing in several Cafés or Coffee Shops whose building constructions were closed, including Premier Cafe, Polytechnic Canteen, and Radja Kopi Café.

Table 3. Testing Criteria

Nama Café	Room Area(meters)	Number of Smokers	Fast rate (%)	Room Criteria	Information
King Coffee	8 x 8 m	15	22, 24, 25, 27	Semi Closed	4 Fans
Premier	8 x 7 m	18	21,22,22,26,27,	Semi Closed	2 Fans

Coffee			30,32,33,35,36, 39, 42, 46		
Poltas Canteen	4x5 m	17	55,50,43,39,28, 27,26,25,24,23, 22,21,21,20,22, 21,19,19,20	Open	No Fans

### DISCUSSION

Testing of the detection and cleaning system of cigarette smoke was carried out at three different locations, namely at Raja coffee, Primer Caffe, and Poltas Kantin, and the results showed that open spaces had higher CO<sub>2</sub> levels than closed spaces because they were easy to detect and clean using a colling fan.

### CONCLUSION

The ability of this smoke detector to detect the presence of cigarette smoke in the air depends on the concentration of smoke, the distance from the source and sensor, and the direction of movement of the smoke. and from the results of tests carried out at three locations, it was explained that a closed room equipped with a colling fan to clean cigarette smoke levels made the room cleaner and reduced co<sub>2</sub> levels.

### REFERENCES

- Candra, R. A., Suherman, & Ilham, D. N. (2021). Amplitude range data validation in Internet of Things (IoT) sensor. *IOP Conference Series: Earth and Environmental Science*, 644(1). <https://doi.org/10.1088/1755-1315/644/1/012063>
- Candra, Rudi Arif, Ilham, D. N., Hardisal, H., & Sriwahyuni, S. (2019). Light Control Design by Using Social Media Telegram Applications Based on Internet Of Things (IOT). *Sinkron*, 3(2), 200. <https://doi.org/10.33395/sinkron.v3i2.10094>
- Candra, Rudi Arif, Saputra, D. S., Ilham, D. N., Setiawan, H., & Hardisal, H. (2020). The Infusion of Notification Design With an Application of Social Media Based on a Internet of Things (IOT). *Sinkron*, 5(1), 129. <https://doi.org/10.33395/sinkron.v5i1.10610>
- Gustavia, R. A., & Nurraharjo, E. (2018). Rancang Bangun Sistem Multiple Warning Deteksi Asap Rokok. *Prosiding SINTAK 2018*, 278–282.
- Hamdani, D., Handayani, E., & Risdianto, E. (2019). Rancang Bangun Alat Pendeteksi Asap Rokok Dan Nyala Api Untuk Penanggulangan Kesehatan Dan Kebakaran Berbasis Arduino Uno Dan GSM SIM900A. *Jurnal Ilmu Fisika | Universitas Andalas*, 11(1), 37–46. <https://doi.org/10.25077/jif.11.1.37-46.2019>
- Ihsan, I., Ilham, D. N., Candra, R. A., Yunan, A., & Hardisal, H. (2020). Design of an Automatic Water Pump on a Traditional Boat. *Sinkron*, 5(1), 100. <https://doi.org/10.33395/sinkron.v5i1.10635>
- Ilham, D. N., Balkhaya, B., Candra, R. A., Hardisal, H., & Hasbaini, H. (2020). Designing an Arduino-based Automatic Cocoa Fermentation Tool. *Sinkron*, 5(1), 92–99. <https://doi.org/10.33395/sinkron.v5i1.10611>
- Ilham, D. N., Hardisal, H., Balkhaya, B., Candra, R. A., & Sipahutar, E. (2019). Heart Rate Monitoring and Stimulation with the Internet of Thing-Based (IoT) Alquran Recitation. *Sinkron*, 4(1), 221. <https://doi.org/10.33395/sinkron.v4i1.10392>
- Ilham, D. N., Satria, E., Anugreni, F., Candra, R. A., & Kusumo, H. N. R. A. (2021). Rain Monitoring System for Nutmeg Drying Based on Internet of Things. *Journal of Computer Networks, Architecture, and High-Performance Computing*, 3(1), 52–57. <https://doi.org/10.47709/cnahpc.v3i1.933>
- Mandarani, P., Ariani, R., Jurusan, D., Informatika, T., Industri, F. T., Jurusan, M., ... Nanggalo, K. (2016). Perancangan Sistem Deteksi Asap Rokok Menggunakan Layanan Short Message Service ( Sms ) Alert Berbasis Arduino. *Jurnal TEKNOIF*, 4(2), 66–75. <https://doi.org/10.21063/JTIF.2016.V4.2.66-75>
- Rahmadani, S. (2018). *Perancangan Alat Pendeteksi Asap pada Ruang Bebas Rokok Menggunakan Sensor MQ-2 dengan Mikrokontroler Atmega328*.
- Rahmat, A., Somawirata, I. K., & Nasional, I. T. (2018). *Rancang Bangun Alat Pendeteksi Dan Penetralisir Asap Rokok Dalam RUangan Menggunakan Metode PI (Proportional Integral) Berbasis Arduino*. 1–8.
- Ratnasari, I. D. (2018). Rancang Bangun Alarm Deteksi Asap Rokok dan Kebisingan Pada Ruang Kelas Secara Otomatis Berbasis Mikrokontroler. *Elinvo (Electronics, Informatics, and Vocational Education)*, 3(2), 54–60. <https://doi.org/10.21831/elinvo.v3i2.18747>
- Sulistiyowati, I., Findawati, Y., Ayubi, S. K. A., Jamaaluddin, J., & Sulistyanto, M. P. T. (2019). Cigarette detection system in closed rooms based on Internet of Thing (IoT). *Journal of Physics: Conference Series*, 1402(4). <https://doi.org/10.1088/1742-6596/1402/4/044005>
- Utomo, B. T. W., & Saputra, D. S. (2016). Simulasi Sistem Pendeteksi Polusi Ruang Menggunakan Sensor Asap Dengan Pemberitahuan Melalui SMS (Short Message Service) Dan Alarm Berbasis Arduino. *Jurnal Ilmiah Teknologi Informasi Asia*, 10(1), 56–68.
- Waworundeng, J. M. S. (2020). Desain Sistem Deteksi Asap dan Api Berbasis Sensor, Mikrokontroler dan IoT. *CogITo Smart Journal*, 6(1), 117. <https://doi.org/10.31154/cogito.v6i1.239.117-127>