



Aalborg Universitet

AALBORG UNIVERSITY
DENMARK

Carrier Aggregation for LTE-Advanced

Functionality and Performance Aspects

Pedersen, Klaus Ingemann; Frederiksen, Frank; Rosa, Claudio; Nguyen, Hung Tuan; Garcia, Luis Guilherme Uzeda; Wang, Yuanye

Published in:

I E E E Communications Magazine

DOI (link to publication from Publisher):

[10.1109/MCOM.2011.5783991](https://doi.org/10.1109/MCOM.2011.5783991)

Publication date:

2011

Document Version

Early version, also known as pre-print

[Link to publication from Aalborg University](#)

Citation for published version (APA):

Pedersen, K. I., Frederiksen, F., Rosa, C., Nguyen, H. T., Garcia, L. G. U., & Wang, Y. (2011). Carrier Aggregation for LTE-Advanced: Functionality and Performance Aspects. *I E E E Communications Magazine*, 49(6), 89-05. <https://doi.org/10.1109/MCOM.2011.5783991>

General rights

Copyright and moral rights for the publications made accessible in the public portal are retained by the authors and/or other copyright owners and it is a condition of accessing publications that users recognise and abide by the legal requirements associated with these rights.

- ? Users may download and print one copy of any publication from the public portal for the purpose of private study or research.
- ? You may not further distribute the material or use it for any profit-making activity or commercial gain
- ? You may freely distribute the URL identifying the publication in the public portal ?

Take down policy

If you believe that this document breaches copyright please contact us at vbn@aub.aau.dk providing details, and we will remove access to the work immediately and investigate your claim.

Carrier Aggregation for LTE-Advanced: Functionality and Performance Aspects

Klaus Ingemann Pedersen, Luis Guilherme Uzeda Garcia, Hung Nguyen,
Yuanye Wang, Frank Frederiksen, Claudio Rosa

Abstract – Carrier aggregation (CA) is one of the key features for LTE-Advanced. By means of CA, users gain access to a total bandwidth of up to 100 MHz in order to meet the IMT-Advanced requirements. The system bandwidth may be contiguous, or composed of several non-contiguous bandwidth chunks, which are aggregated. This paper presents a summary of the supported CA scenarios as well as an overview of the CA functionality for LTE-Advanced with special emphasis on the basic concept, control mechanisms, and performance aspects. The discussion includes definitions of the new terms primary cell (PCell) and secondary cell (SCell), mechanisms for activation and deactivation of CCs, and the new cross-CC scheduling functionality for improved control channel optimizations. We also demonstrate how CA can be used as an enabler for simple yet effective frequency domain interference management schemes. In particular, interference management is anticipated to provide significant gains in heterogeneous networks, envisioning intrinsically uncoordinated deployments of home base stations.

I. Introduction

The first version of long term evolution (LTE) was completed in March 2009 as part for 3GPP Release-8 (Rel-8) [1]. LTE is based on flat radio access network architecture without a centralized network component, offering flexible bandwidth options ranging from 1.4 MHz to 20 MHz using orthogonal frequency division multiple access (OFDMA) in the downlink and single-carrier frequency division multiple access (SC-FDMA) in the uplink [1]. Multiple-input-multiple-output (MIMO) up to order 4x4 are supported for the downlink, while only single layer transmission is supported in the uplink. In March 2008, 3GPP started a new study item in order to further develop LTE towards LTE-Advanced targeting the IMT-Advanced requirements as defined by the International Telecommunications Union (ITU) [2]-[5]. The LTE-Advanced study item was closed March-2010. The outcome was a set of new radio features, which are currently being standardized to become part of LTE-Advanced in 3GPP Rel-10.

Carrier aggregation (CA) is one of the main features for LTE-Advanced in Rel-10 for meeting the peak data rate requirements of IMT-Advanced, namely 1 Gbps and 500 Mbps for the downlink and uplink, respectively [6]. This paper provides a thorough overview of CA for LTE-Advanced, while elucidating its impact on the overall system design and performance. Although we primarily focus on CA for the downlink of frequency division duplex systems, CA is supported in the uplink as well as in time division duplex systems [7].

CA is designed to be backward compatible, meaning that legacy Rel-8 and Rel-9 users should still be able to co-exist with LTE-Advanced on at least part of the total bandwidth. Thus, each individual spectrum chunk, denoted component carrier (CC), inherits the core physical layer design and numerology from LTE Rel-8. Nevertheless, the introduction of CA for LTE-Advanced does include new functionalities and modifications to the link layer and radio resource management (RRM) framework. In our description of such modifications for LTE-Advanced, we

assume that the corresponding LTE Rel-8 design is known by readers, who may otherwise refer to [1], [8], [9] for additional information.

Additionally, we discuss the potential of CA as an enabler for new frequency domain interference management schemes, providing attractive gains for heterogeneous environments with dense deployment of small base station nodes (e.g. pico or home base stations). For example, a fully distributed interference management concept with a CC resolution, called autonomous component carrier selection (ACCS) has been proposed in [10].

A set of system level performance results are presented in order to demonstrate the benefits of CA. In particular, we focus on comparing the performance of N separate LTE Rel-8 carriers versus using CA of N carriers. The performance comparison is presented for a dynamic birth-death traffic model to illustrate how the performance varies with the offered traffic per cell. Performance results for heterogeneous networks with dense deployment of small base station nodes are also presented in order to illustrate the potential of the developed ACCS concept.

The rest of the paper is organized as follows; Section II outlines the scenarios and basic assumptions for CA configurations. The CA functionality and impact on radio resource management (RRM) algorithms is described in Section III. Section IV addresses interference management on a carrier resolution, followed by presentation of performance results in Section V. Finally, Section VI recapitulates the main findings and points out to future work.

II. CA scenarios and CC types

The maximum supported bandwidth for LTE-Advanced of 100 MHz can be achieved via CA of 5 CCs of 20 MHz as illustrated in Fig. 1a. Thus, an LTE-Advanced user supporting such high bandwidths can be served simultaneously on all 5 CCs. The bandwidth of each CC follows the LTE Rel-8 supported bandwidth configurations, meaning 1.4, 3, 5, 10, 15, and 20 MHz. The aggregated CCs may be contiguous as illustrated in Fig. 1a, or non-contiguous as depicted in Fig. 1b. Notice also from the example in Fig. 1b that the aggregated CCs can in principle also have different bandwidths. The support for both contiguous and non-contiguous CA of CCs with different bandwidths offers significant flexibility for efficient spectrum utilization, and gradual re-farming of frequencies previously being used by other systems such as e.g. Global System for Mobile Communications (GSM) or Code Division Multiple Access (CDMA). From an implementation and physical layer perspective, contiguous CA is easier, in the sense that it can be realized with a single Fast Fourier Transform (FFT) and a single Radio Frequency (RF) unit, while non-contiguous CA in most cases requires multiple RF chains and FFTs. The non-contiguous CA cases have additional implications; the radio network planning phase and the design of the RRM algorithms need to take into account that different CCs will exhibit different path loss and Doppler shifts. For example, Doppler shift influences on the ability to gain from frequency domain packet scheduling within a CC [8].

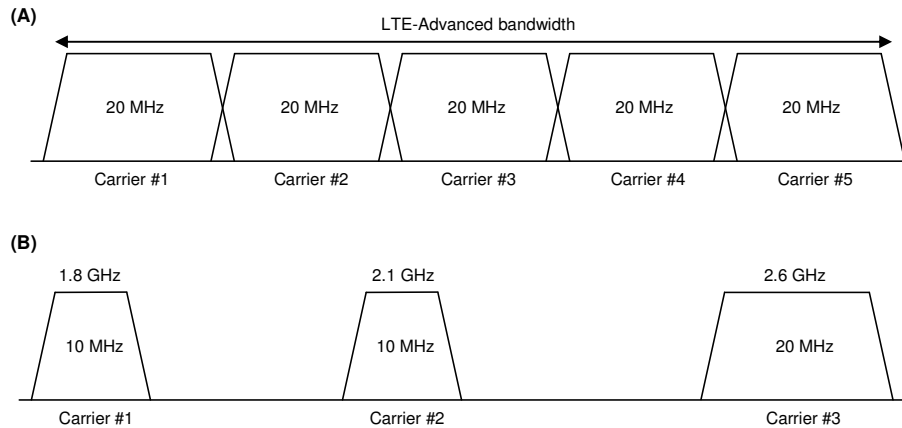

Fig. 1: Example of carrier aggregation scenarios: Contiguous aggregation of 5 component carriers with equal bandwidth (A) and non-contiguous aggregation of component carriers with different bandwidths.

Notice that for LTE Rel-8 with frequency division duplex (FDD), uplink and downlink carriers are always paired with options for defining the frequency duplex distance and bandwidth through system information signaling. With CA it is also possible to have asymmetric configurations, so there for example is multiple downlink CCs configured for a UE and only one uplink CC. The linking between uplink and downlink configured CCs is signaled to the UE with higher layer signaling. For each LTE-Advanced user, a CC is defined as its Primary cell (PCell) [7]. Different users may not necessarily use the same CC as their PCell. The PCell can be regarded as the anchor carrier for the terminal and is thus used for basic functionalities such as radio link failure monitoring. If more than one CC is configured for user, the additional CCs are denoted as Secondary Cells (SCells) for the user.

III Functionality and terminology

III-A Protocol stack

Figure 2 shows an overview of the downlink user plane protocol stack at the base station, as well as the corresponding mapping of the most essential RRM functionalities for CA. Each user has at least one radio bearer, denoted the default radio bearer. The exact mapping of data to the default bearer is up to the operator policy as configured via the Traffic Flow Template (TFT). In addition to the default radio bearer, users may have additional bearers configured. There is one Packet Data Convergence Protocol (PDCP) and Radio Link Control (RLC) per radio bearer, including functionalities such as robust header compression (ROHC), security, segmentation, outer automatic repeat request (ARQ), etc. Thus, the PDCP and RLC are the same as in LTE Rel-8 [1],[8],[9]. The interface between the RLC and the Medium Access Control (MAC) is referred to as *logical channels*. There is one MAC per user, which controls the multiplexing (MUX) of data from all logical channels to the user, and how this data is transmitted on the available CCs. As illustrated in Fig. 2, there is a separate Hybrid ARQ (HARQ) entity per CC, which essentially means that transmitted data on CC #X shall also be retransmitted on CC #X in case prior transmission(s) are erroneous. The interface between the MAC and physical layer (PHY) layer – denoted *transport channels* – is also separate for each CC. The transport blocks sent on different CCs can be transmitted with independent modulation and coding schemes, as well as different MIMO coding schemes. The latter allows that data on one CC is transmitted with open loop transmit diversity, while data on another CC is sent with dual stream closed loop pre-coding.

Thus, there is independent link adaptation per CC to benefit from optimally matching the transmission on different CCs according to the experienced radio conditions, i.e. corresponding to frequency domain link adaption on a CC resolution. The system also allows for using different transmit power settings for the CCs, so that they in principle could have different levels of coverage as also discussed in [7].

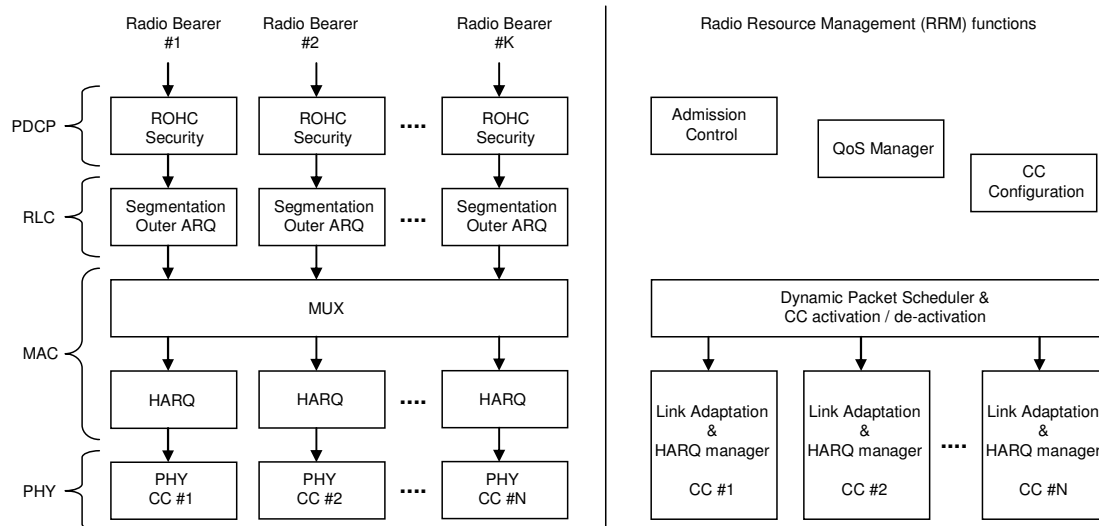

Fig. 2: Overview of the downlink user plane architecture (left side) and the corresponding RRM algorithms (right side).

The LTE Rel-8 control plane protocol stack also applies to LTE-Advanced with multiple CCs, meaning that there is one Radio Resource Control (RRC) per user, independent of the number of CCs. Similarly, idle mode mobility procedures of LTE Rel-8 also apply in a network deploying CA. It is also possible for a network to configure only a subset of CCs for idle mode camping.

III-B RRM considerations

The RRM framework for LTE-Advanced has many similarities with that of LTE Rel-8 [9]. Admission control is performed at the base station prior to establishment of new radio bearers, and the corresponding quality of service (QoS) parameters are configured. The QoS parameters are the same for LTE Rel-8 and LTE-Advanced, and are thus CC independent – see more information in [1], [8], [9]. However, a new RRM functionality is introduced with LTE-Advanced, which we refer to as *CC configuration* in the following. The latter functionality configures a CC set for each user. The CC set is the collection of CCs where the user may afterwards be scheduled. The CC set is configured to the users with RRC signaling. The CC configuration functionality is an important apparatus for optimizing the system performance, as well as limiting the power consumption for the users. The latter originates from the fact that the power consumption per user increases with the number of CCs that a user has to receive (i.e. increases with bandwidth it needs to process). The overall framework for the CC configuration is illustrated in Fig. 3, where an example of input information is illustrated. For each user, QoS parameters, radio bearer configuration, and terminal capability are useful a priori knowledge for determining the CC set. Legacy Rel-8 users naturally only support one CC, and shall therefore only be allocated on a single CC. For optimal system performance, it is desirable to have

approximately equal load on different CCs, so own-cell load information (including load per CC) is needed as input as well to facilitate optimal CC load balancing and configuration [11]. For LTE-Advanced users supporting multiple CCs, QoS parameters such as the QoS class identifier (QCI), guaranteed bit rate (GBR), and the aggregated maximum bit rate (AMBR) for non-GBR bearers provide useful information for determining the number of required CCs for the user. As an example, users only having a voice over IP (VoIP) call or a streaming connection with moderate GBR can be assigned a single CC, while still being able to fulfill the users QoS requirements. For users with best effort traffic, the AMBR can be used to estimate the most sensible CC set size for such users. Assigning a single CC to such user has the advantage that terminal power consumption is kept lower, as compared to cases where the user is configured with a CC set larger than one. Secondly, corresponding control signaling overhead is also reduced by configuring a smaller number of CCs for the user. The exact algorithm for the CC configuration functionality is base station vendor specific, and thus not strictly specified in the standard.

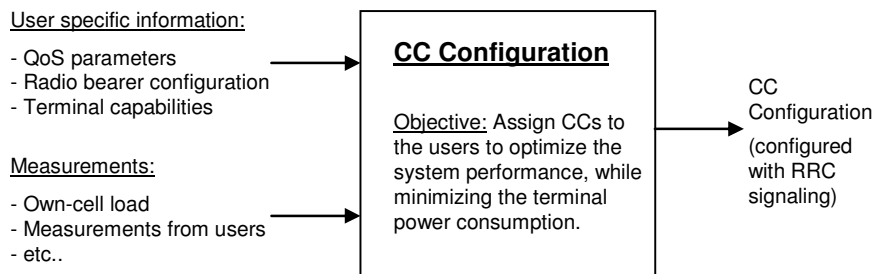

Fig. 3: Overview of CC Configuration functionality, including illustration of possible input parameters.

As illustrated in Fig. 2, the Layer-2 packet scheduler (PS) is tightly coupled with an additional functionality for more dynamically (de-)activating CCs configured as SCells for the different users. This functionality is anticipated as an additional control tool to further optimize the users' power consumption. A user is only schedulable on configured and activated CCs, while it is not schedulable on deactivated CCs. Similarly, a user does not report channel state information (CSI) for deactivated CCs as needed by the base station for radio channel aware link adaptation and frequency domain packet scheduling [9]. SCells are activated/de-activated independently via MAC signaling [7]. It is furthermore possible to set a so-called deactivation timer, so an activated SCell automatically gets deactivated without explicit deactivation message if no traffic has been scheduled on the CC for a given time-period. Configured SCells are by default de-activated, so they have to be explicitly activated before being schedulable. However, the PCell for a user is always assumed to be activated and is therefore not subject to any deactivation procedures [7].

The dynamic PS at Layer-2 is responsible for scheduling the eligible users on their configured and activated CCs. In coherence with LTE Rel-8 PS framework [9], the smallest frequency domain scheduling resolution within each CC is a physical resource block (PRB) of 12 sub-carriers, constituting an equivalent bandwidth of 180 kHz. The PS aims at benefiting from multi-user frequency domain scheduling diversity by primarily allocating PRBs to the different users that experience good channel quality (i.e. avoid to schedule users on PRBs in deep fades). The PS functionality for LTE-Advanced with CA is very similar to the PS for LTE Rel-8, except that the LTE-Advanced PS is allowed to schedule users across multiple CCs. The fact that LTE-Advanced relies on independent transport blocks, link adaptation, and HARQ per CC opens for various implementations of the scheduler. As an example, the scheduling could be done in

parallel for the different CCs, including some coordination to ensure fairness and joint control for users being scheduled on multiple CCs [11]. As in LTE Rel-8, dynamic scheduling of a user is facilitated via sending a scheduling grant on the control channel (called the physical dedicated control channel - PDCCH), which is time-multiplexed in each TTI just before the data channel [9]. One PDCCH is limited to one CC, and the same addressing is used per user independent on the CC where it is scheduled (called the cell radio network temporary identifier, C-RNTI, in 3GPP LTE terminology). However, LTE-Advanced includes enhancements allowing the base station to send a scheduling grant on one CC for scheduling the user on another CC. The latter is referred to as cross-CC scheduling as the scheduling grant and the corresponding data transmission takes place on different CCs. The cross-CC scheduling functionality is incorporated by appending a so-called carrier indicator field (CIF) to the downlink control information (DCI). The DCI is used to indicate the user allocations for uplink and downlink traffic, and the CIF is used to address which CC the user data is transmitted on. When the CIF is appended to the DCI, the payload size increase slightly, and as the radio resources for the transmission of the data is constant, the link performance is slightly worse due to weaker coding. The user configuration and interpretation of the CIF is semi-statically configured on a per-UE basis, and is thus fully backwards compatible with legacy Rel-8 users not having the CIF in the DCI transmitted on the PDCCH. The cross-CC scheduling functionality offers additional system flexibility for further optimizing control and data channel performance across multiple CCs.

In addition to the dynamic Layer-2 packet scheduling, LTE Rel-8 also supports so-called semi-persistent-scheduling (SPS) as a special packet scheduling mode for quasi-deterministic traffic flows such as VoIP to save control channel resources [9]. SPS is also supported for LTE-Advanced with CA, but is limited to be configured on the users PCell only (configured via RRC signaling).

IV. Dynamic interference management

For properly planned macro cellular networks, it has typically been found that deployment of LTE (or LTE-Advanced) with plain frequency reuse one is an attractive configuration: simply put, all cells have access to all CCs. However, on heterogeneous networks (HetNet) the interference footprint deviates significantly from that of planned macro cells. This arises from the coexistence of the ordinary macro cell layer with a layer of scattered smaller base station such as micro, pico, and home base stations (HeNB) with closed subscriber groups (CSG). Specifically, dense roll-outs of co-channel CSG HeNBs, popularly known as femtocells, are bound to result in chaotic inter-cell interference if left completely unchecked. It has therefore been found that HetNet cases in many scenarios can benefit from interference management. It then follows naturally, that CA could be employed as a new and promising instrument of inter-cell interference coordination in the frequency domain.. The frequency reuse, i.e. CC, configuration yielding the most attractive performance is time-variant and depends on many factors such as the traffic distribution, the relative location of base stations, their mutual interference coupling, etc. Thus, manual configuration of the optimal CC usage pattern becomes nearly impossible.

In an ideal world, each base station node would dynamically select from a finite set which CCs it should deploy. Fig. 4 shows an example of a scenario with three available CCs for each base station node. The selected CCs by each node are marked with the grey color code, meaning that e.g. the macro eNB is using all three CCs. For the densely deployed indoor HeNBs / pico nodes, each node only uses a subset of available CCs, as this is the best configuration for optimizing the system performance as there is severe interference coupling between those nodes. Notice that by conducting the adaptive frequency reuse on CC resolution, both data and control channels experience benefits as all physical channels are within a single CC.

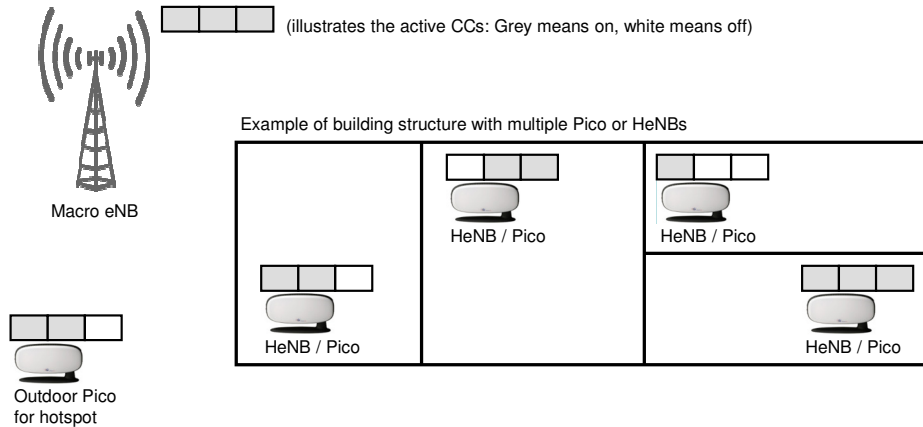

Fig. 4: Simple illustration of autonomous CC selection (ACCS) principle for heterogeneous networks.

In this light, a concept called autonomous CC selection (ACCS) has therefore been proposed. The interested reader can find a comprehensive description of ACCS in [10], yet its key principles are outlined next. The basic ACCS concept is based on three fundamental premises: (i) Each base station node has the right to always have at least one active CC with full cell coverage. (ii) As the offered traffic increases, additional CCs can be taken into use to increase its capacity. (iii) However, a base station node is only allowed to take additional CCs into use, provided it does not result in excessive interference to the surrounding cells. The condition expressed in (iii) shall prevent so-called greedy base station nodes from generating disruptive interference levels that severely reduce the performance of surrounding cells. Thus, before a node takes additional CCs into use, it shall estimate the impact on the surrounding cells. The latter evaluation relies on Background Interference Matrices (BIMs) which are built locally by each HeNB based exclusively on *downlink* reference signal received power (RSRP) measurements. Such measurements are processed in a meaningful way and subsequently exchanged among HeNBs. The BIM information essentially predicts the downlink carrier to interference ratios (C/I) experienced whenever two cells (serving and interferer) use the same CC at the same time with equal transmit power spectrum densities. Consequently, by collecting RSRP measurements from the terminals for different cells, each eNB “learns” the interference coupling with neighbouring cells in terms of C/I ratios. It is relevant to mention that the collection of various measurements is a by-product of normal system operation and does not entail an extra burden to UEs. Thus, ACCS is essentially a fully distributed and dynamic interference management concept operating in the frequency domain on a CC resolution, based on sensing (measurements) and minimal signaling between base station nodes. A related autonomous carrier selection concept is outlined in [12].

V. Performance of CA

In order to further illustrate the gain of using CA, extensive system level simulations are conducted for a configuration with 2x20 MHz in the downlink. The considered environment is a standard 3-sector macro cellular layout with 500 meter inter-site distance and a 2x2 antenna

configuration with rank adaptation (also known as macro case #1 environment by 3GPP in Technical Report 36.814). Simulations are conducted for cases where all users are legacy Rel-8 (single CC per user) as well as for cases where all users are LTE-Advanced, and thus are schedulable on multiple CCs. For the cases with Rel-8 users, we use a simple round robin CC load balancing approach, where we aim at having the same number of users allocated on each CC [11]. Frequency domain radio channel aware proportional fair scheduling is applied within each CC. A dynamic birth-death traffic model is considered, where new users arrive in the system according to a homogenous Poisson process (birth process) [3]. The payload for each best effort user equals 4 Mbit, and once this data amount has been successfully delivered to the user the call is terminated (death process). Fig. 5 shows the mean experienced, 5%-ile (outage), and 95%-ile (peak) user data rates versus the average offered traffic per cell. At low offered traffic, it is observed that LTE-Advanced with CA offers significant gains in both mean experienced user data rates and outage performance. A two-fold improvement is exhibited for the LTE-Advanced cases due to using two CCs as compared to the legacy Rel-8 users that are restricted to a single CC. Thus, when there is only a single user in the cell (low offered load), the LTE-Advanced user has access to double bandwidth for this particular example, and hence experience twice as good performance. As the average offered traffic per cell increases to the point where multiple simultaneously schedulable users are present at both CCs for both the Rel-8 and LTE-Advanced cases, the gap between experienced data rate of the two user categories diminishes. This behavior is observed because the user experienced performance for large values of N-users is approximately the same independently of whether N-users are multiplexed across 2 CCs, or two groups of N/2 users are multiplexed on each CC. The latter observation links to discussions in Section III-B and Fig. 3, where we recommended that the number of CCs configured per user is done as a function of own-cell load. Thus, for highly loaded cells, one may as well configure single CC per user to save on terminal power consumption.

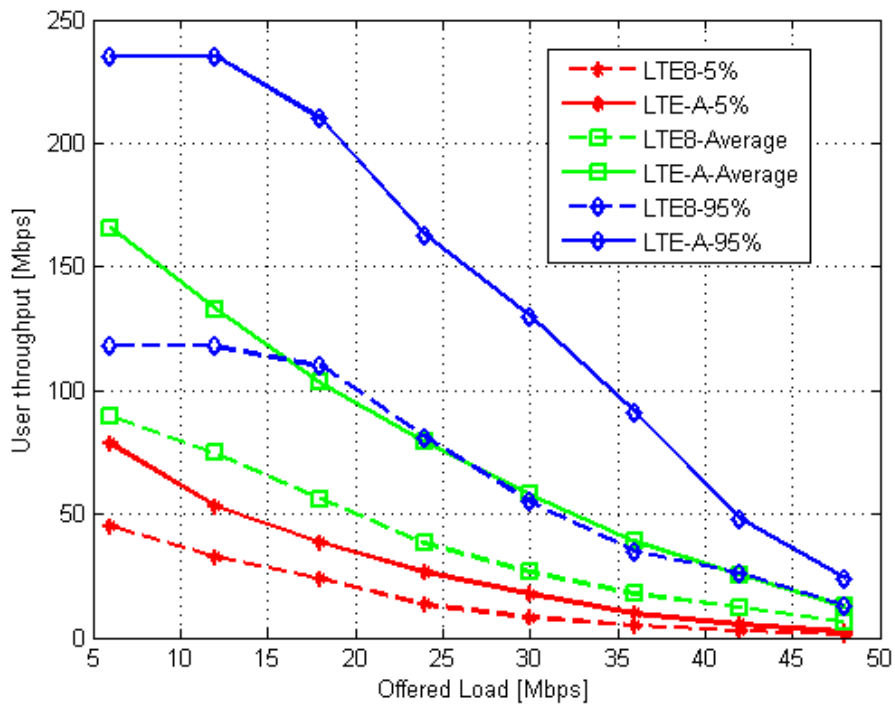

Fig. 5: Experienced user throughput performance versus the average offered load per cell.

In order to further exemplify the possibilities opened by CA, the performance of the proposed autonomous interference management concept for local areas (ACCS) is illustrated in Fig. 6 for a case with three CCs. The three curves shown therein are the result of extensive simulations modeling a dense urban environment with two building blocks separated by a 10m wide street, totaling 120 apartments. Each block consists of 60 apartments, 20 per floor, assuming a CSG access policy. In our analysis, the probability of having a HeNB deployed and a single active LTE-Advanced user per apartment assumed the values of 25%, 50% and 75% in order to emulate the transition from slightly sparser to extremely dense HeNB deployments. Both HeNBs and UEs are dropped uniformly at random indoor locations, while macro-cells are not considered here. A full buffer traffic model is assumed. Figure 6 shows the relative performance for two different static frequency reuse schemes (labelled R1 and R3) and ACCS. Here R1 refers to plain reuse one (all CCs used by all HeNBs, while R3 corresponds to reuse 3, i.e. each HeNB only uses one of the three available CCs). All mean throughput results were normalized by the maximum theoretical capacity of the system. Hence, a normalized throughput of 100% means transmission over the whole bandwidth (all 3 CCs) at the maximum system spectral efficiency.

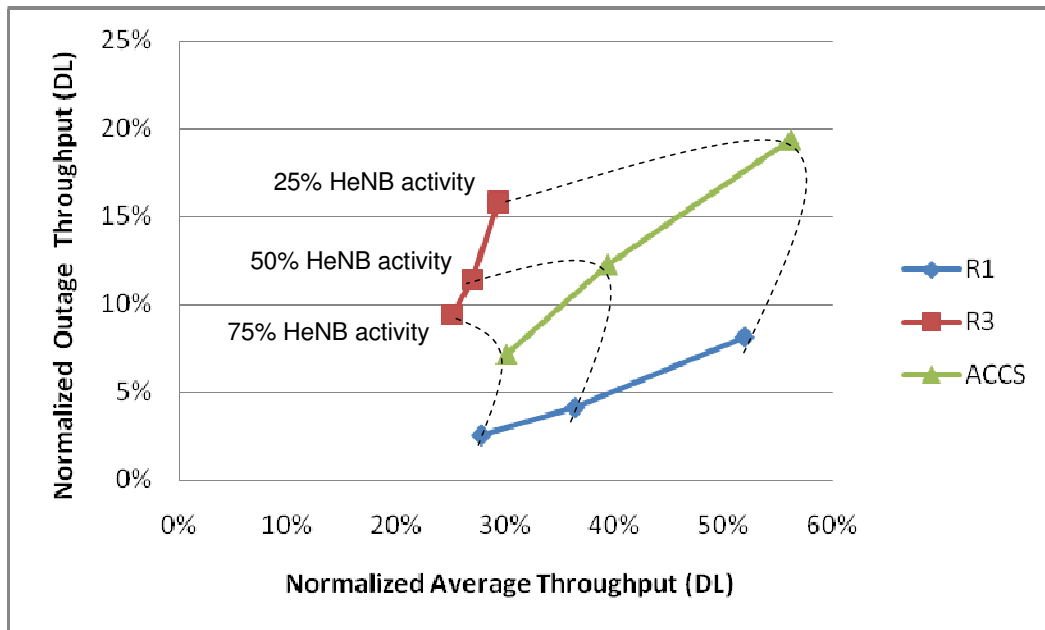

Fig. 6: Relative performance and of different fixed frequency reuse schemes and ACCS for an environment with densely deployed CSG HeNBs.

When compared to universal reuse, the simple yet adaptive nature of ACCS leads to a vastly superior performance in terms of experienced 5%-ile (outage) data rates, on par with those offered by sparser and often unpractical pre-planned frequency patterns. This trait is especially relevant in very dense deployments, represented by the leftmost points of each curve in Fig. 6. Additionally, it also retains the benefits offered by universal reuse in terms of average data rates, simply because ACCS, as opposed to sparser reuse schemes, does not render cells severely bandwidth-limited when that is absolutely not required e.g. in sparser deployments. In fact, it may even surpass the performance of universal reuse, since it allows for a sensible trade-off between

bandwidth and signal to interference plus noise ratio. The latter becomes evident when the rightmost points of each curve are compared.

VI. Conclusion

In this article we outlined the basic CA concept for LTE-Advanced with both contiguous and non-contiguous aggregation of bandwidths up to 100 MHz. The larger bandwidth obviously results in improved user data rates. But equally important, CA is a powerful feature that enables more flexible and optimal utilization of frequency assets. Especially, non-contiguous CA offers new opportunities for gradually starting to use more and more frequency resources for LTE in different bands that previously were used for e.g. GSM or CDMA without suffering in peak data rates. CA for LTE-Advanced is fully backward compatible, which essentially means that legacy Rel-8 terminals and LTE-Advanced terminals can co-exist. The latter is achieved by relying on MAC level CA with independent Release-8 compliant HARQ and link adaptation per CC. This also implies that CA is transparent from Layer-3 and upwards for the user-plane. A flexible layered approach for managing the CCs per LTE-Advanced user is defined; offering configuration of CCs per user via RRC signaling, followed by MAC signaling for activation/de-activation of CCs configured as SCells. The aforementioned control procedures facilitate efficient power management of terminals, so they are not always mandated to operate at their full bandwidth capability. We have also demonstrated how CA offers attractive opportunities for managing the interference in heterogeneous networks with a mixture of macro cells and various local area smaller base stations (e.g. pico and home base stations). The presented autonomous CC selection concept offers attractive gains for such cases, and can be regarded as a “light cognitive radio” solution, which is facilitated via special use of CA combined with sensing (i.e. based on measurements).

As a last remark, it should be noted that the final standardization of CA for LTE Rel-10 is currently ongoing. In order to meet the IMT-Advanced peak data rate requirements of 1 Gbps in downlink and 500 Mbps in uplink, when standardizing the RF requirements 3GPP has initially focused on intra-band aggregation of carriers with a channel bandwidth larger than or equal to 10 MHz to form an aggregated bandwidth of up to 40 MHz. Currently new bandwidth combinations for inter-band CA are being agreed in standardization to cover the most interesting cases for operators around the world. To speed up the standardization work, different time scales are set for downlink and uplink so that Rel-10 will only support inter-band CA in downlink and for a limited number of bandwidth combinations, while full support for non-contiguous CA will come with Rel-11. However, all the related signaling procedures for CA in Rel-10 are standardized so that CA over other bands for both downlink and uplink can be added in later releases by specifying the RF requirements for the corresponding bandwidth combinations.

VII Acknowledgements

We highly appreciate the joint carrier aggregation work done together with many of our Nokia and Nokia Siemens Networks colleagues, as well as all the received comments and advice during the studies that made the writing of this paper possible.

VIII References

- [1] H. Holma, A. Toskala (editors) “LTE for UMTS, OFDMA and SC-FDMA Based Radio Access”, John Wiley & Sons Ltd, 2009.
- [2] C. Wijting, et.al., “Key Technologies for IMT-Advanced Mobile Communication Systems”, in IEEE Wireless Communications, pp. 76-85, June 2009.

- [3] 3GPP Technical Report 36.814, "Further Advancements for E-UTRA Physical Layer Aspects", Version 9.0.0, March 2010, Available at www.3gpp.org.
- [4] 3GPP Technical Report 36.912, "Feasibility study for Further Advancements for E-UTRA (LTE-Advanced)", Version 9.2.1, March 2010, Available at www.3gpp.org
- [5] P. E. Mogensen, et.al., "LTE-Advanced: The path towards gigabit/s in wireless mobile communications", in IEEE Proc. Wireless Communication, Vehicular Technology, Information Theory and Aerospace & Electronic Systems Technology (VITAE), pp. 147-151, May, 2009.
- [6] G. Yuan, et.al., "Carrier Aggregation for LTE-Advanced Mobile Communication Systems", in IEEE Communications Magazine, pp. 88-93, February 2010.
- [7] M. Iwamura, et.al., "Carrier Aggregation Framework in 3GPP LTE-Advanced", in IEEE Communications magazine, pp. 60-67, August 2010.
- [8] A. Larmo, et.al., "The LTE Link-Layer Design", in IEEE Communications Magazine, pp. 52-59, June 2009
- [9] K.I. Pedersen, et.al., "An Overview of Downlink Radio Resource management for UTRAN Long-Term Evolution", in IEEE Communications Magazine, pp. 86-93, July 2009
- [10] L. Garcia, et.al., "Autonomous Component Carrier Selection: Interference Management in Local Area Environments for LTE-Advanced", in IEEE Communications Magazine, pp. 110-116, September 2009.
- [11] Y. Wang, et.al., "Carrier Load Balancing and Packet Scheduling for Multi-Carrier Systems" in IEEE Transactions on Wireless Communications, pp. 1780-1789, May-2010.
- [12] J. Li, et.al., "Flexible Carrier Aggregation for Home Base Station in IMT-Advanced System", in Proc. of the 5th International Conference on Wireless communications, networking and mobile computing (WiCOM), pp. 285-288, September 2009.