



AALBORG UNIVERSITY
DENMARK

Aalborg Universitet

Discussion on Laboratory Methods

Jacobsen, H. Moust

Published in:
X ICSMFE

Publication date:
1981

Document Version
Publisher's PDF, also known as Version of record

[Link to publication from Aalborg University](#)

Citation for published version (APA):
Jacobsen, H. M. (1981). Discussion on Laboratory Methods. In *X ICSMFE: Stockholm, 1981*

General rights

Copyright and moral rights for the publications made accessible in the public portal are retained by the authors and/or other copyright owners and it is a condition of accessing publications that users recognise and abide by the legal requirements associated with these rights.

- ? Users may download and print one copy of any publication from the public portal for the purpose of private study or research.
- ? You may not further distribute the material or use it for any profit-making activity or commercial gain
- ? You may freely distribute the URL identifying the publication in the public portal ?

Take down policy

If you believe that this document breaches copyright please contact us at vbn@aub.aau.dk providing details, and we will remove access to the work immediately and investigate your claim.

Discussion on laboratory methods

SYNOPSIS Certain mechanical properties of soils are measured in the laboratory in order to enable the engineer to predict the behaviour of soil structures. For practical applications strain and strength parameters are normally determined by means of oedometers, triaxial apparatuses or shear boxes. In research laboratories a wide range of more complicated apparatuses are available. All these different types of laboratory equipments are also used to set up constitutive relationships for soils in order to support new developments in the field of soil mechanics. Unfortunately the results obtained by different methodologies are not always in accordance. This problem is discussed in the present paper through an analysis of some well-known and very simple testing methodologies.

INTRODUCTION

Soil engineering involves an investigation of the strength and deformation properties of the soil layers in question. The design of foundation constructions also includes theories for calculations of displacements of the structure and its safety against failure. Rather simple theories are normally applied. However complicated theories may occasionally give more realistic solutions to design problems, where sufficient data are available.

The strength and deformation properties of a soil are determined in the laboratory. The deformations of the surface of a soil specimen are measured when stressed by well-known surface loads. For practical applications the soil is assumed to be linearly elastic and the deformation parameters are determined, or it is assumed to be rigid-plastic and the strength parameters are then determined.

In principle there is no difference in the methods used to investigate mechanical properties of a soil specimen or the behaviour of a soil layer stressed by the weight of a construction. In both cases a theory is required to connect the strength and deformation properties with the behaviour of a specimen or construction. But in the laboratory the shape of the specimen and the test conditions can be chosen in a way, which makes the analysis rather simple.

The present paper deals with some testing methods which can give stresses and strains distributed homogeneously so that deformations and loads measured on the surface represent every part of the specimen. For the sake of simplicity only states of two-dimensional (plane) strain will be mentioned in details, and the soil is assumed isotropic.

BASIC CONSIDERATIONS

Soil is normally considered as a continuum. Stresses and strains can then be defined as average values of forces and deformations. When cal-

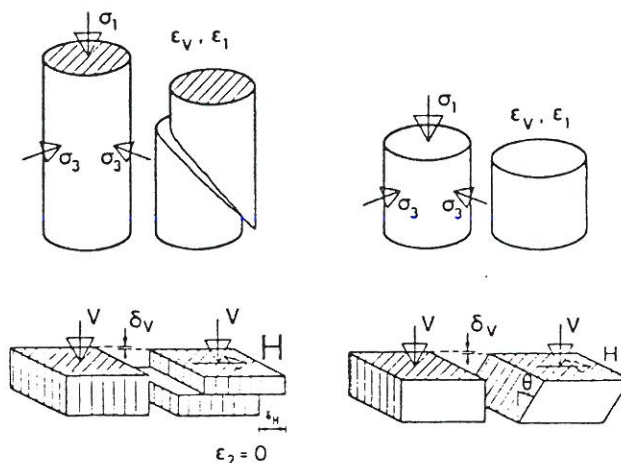

Fig. 1 Some specimens before and after testing. Fixed ends are hatched

culating strain and stress changes inside a soil mass, four criteria should be fulfilled.

Statical condition

If inertia forces can be neglected every little part of a body inside it or on the surface should be in equilibrium.

This condition can be expressed by the well-known Mohr's circle for stresses (Fig. 2a and 2b). The normal stresses are positive as compressions. The shear stress τ is positive when it becomes a positive normal stress by rotating $\pi/2$ clockwise.

Deformation condition

When subjected to boundary forces a body deforms in such a way, that there is a one to one correspondance between points in the body before and after deformation.

This condition can be expressed by the well-known Mohr's circle for strains (Fig. 3a and 3b).

Discussion on laboratory methods

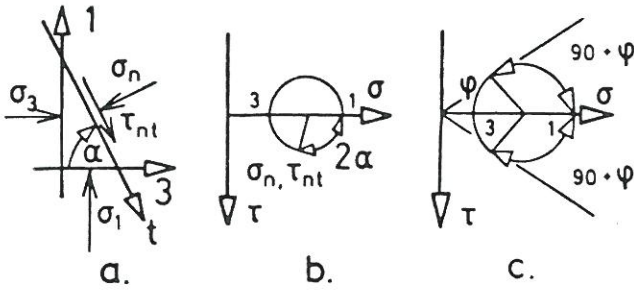

Fig. 2 Mohr's circle for stresses

takes place at constant stress state and soil normally expands (Fig. 3c). By means of Mohr's circle for strain rates, the angle of dilatation ν can be defined. The angle between planes with $\epsilon = 0$ is $90 - \nu$. (Fig. 4b)

Coulomb's failure condition can be combined with Mohr's circle for stresses. Fig. 2c shows that failure takes place in two planes forming an angle of $90 - \phi$ and that the major principal stress bisects the angle (Fig. 4a). By regarding the energy dissipation during plastic flow it can be shown that $\nu \leq \phi$.

The physical condition for a soil can be much more complicated and realistic. It is normally called a stress-strain relationship.

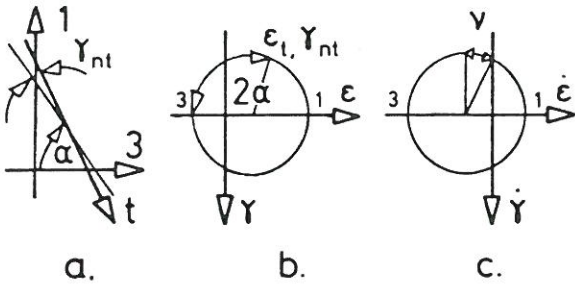

Fig. 3 Mohr's circle for strains

The angular distortion γ is positive for clockwise rotation of the plane, and strains are positive for diminishing.

Principal direction condition

The principal directions of stresses and strains are assumed to coincide. At failure the axis of strain rates and stresses seem to coincide.

Physical condition

The above-mentioned conditions are independent of the nature of the material. The only assumptions are that the continuum remains a continuum and that inertia forces play no role.

The physical conditions of soils are very complex and should be studied in the laboratory in order to find appropriate mathematical simplifications.

If the soil is assumed to fulfil Hooke's law, all conditions can be combined in the theory of elasticity and used in settlement calculations.

If on the other hand perfect plasticity can be assumed the safety against failure can be analysed. At failure a continuing plastic flow

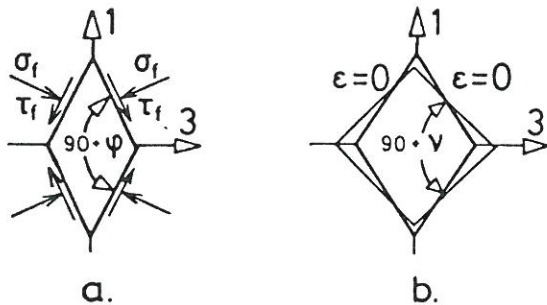

Fig. 4 An element confined by a) failure planes or by b) planes with pure distortion

COMPRESSION TESTS

The test most commonly used to-day is the tri-axial test in which axi-symmetrical states normally occur. In engineering practice the state of plane strain very often occurs and it seems more convenient to use a plane strain apparatus. In the true triaxial apparatus a general three-dimensional stress or strain state can be applied.

These three types of apparatuses have much in common. It is possible to obtain homogeneous stress and strain states throughout the tests. The surface conditions are very simple and do not connect the equilibrium conditions to the deformation conditions. The principal directions are fixed.

In the following plane strain tests should be mentioned, but the principles are valid for all three types of tests.

Fig. 5a indicates, how a vertical load is applied to the specimen through rigid top and bottom platens. A rubber membrane encloses specimen and platens. (Two opposite sides are fixed to ensure plane strain.)

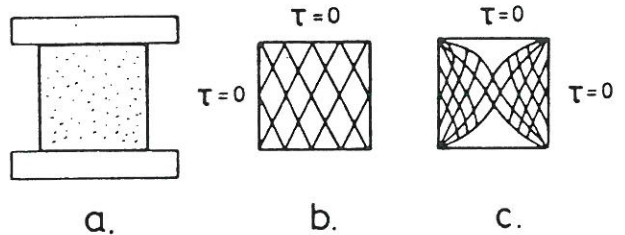

Fig. 5 Compression test with height of specimen equal to the width and b) free ends or c) fixed ends

Statical condition

If a homogeneous stress state occurs, the surface load satisfies the statical condition shown in Fig. 2. The two sides of the specimen are enclosed only by a rubber membrane i.e. $\tau = 0$. Thus these sides are principal planes. The other sides should then be principal planes too. The platens must be smooth.

Fig. 5b shows the failure state, represented by failure planes. Obviously, the relative height H of the sample does not play any role. For practical reasons H is always bigger than or equal to the width W .

If the ends are fixed by rough platens, stiff bodies are created here, and hence the stress

Discussion on laboratory methods

state can be very complex with singularities along the edges. The failure will start at the singularities and from here scatter over the specimen. In unstable materials the influence of fixed ends will be measurable even when the height H is double the width D . The failure planes might develop as illustrated in Fig. 5c. If in this case ($H = W$) the test result is assumed to correspond to a homogeneous stress state the strength of the soil will be overestimated.

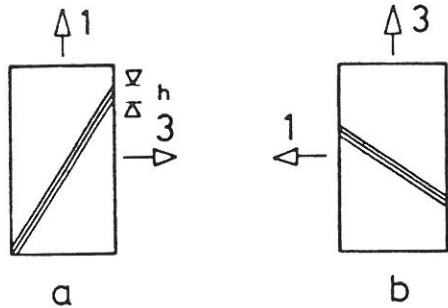

Fig. 6 Compression or extension test with $H = 2 \times W$

Deformation condition

The strain state should also be homogeneous. The vertical sides should continue to be plane even at failure. It can be ensured in compression tests with smooth end platens by using specimen height H equal to the width.

Using unstable soil heterogeneous strain states (Fig. 6) will typically develop during compression tests with $H = 2 \times W$ or extension tests. In this situation a very narrow failure zone is created and the strain ϵ should be relative to the height h of the failure zone and not to the height H of the total specimen. The performance curve will then be too short, and only at the very beginning of the compression phase nearly correct. After failure the curve will be very steep. In unstable soils the maximum stress will be lower than that for homogeneous strain states.

In undrained tests the influence of a nonuniform strain state is considerable for unstable soils. The volume of the whole specimen is kept constant during the test. But in the narrow band where failure later on takes place the soil weakens by taking up water from the surrounding parts of the sample and thus gives too small shear strength. Undrained axi-symmetrical compression tests with fixed pressure heads and $H = 2D$ have been carried out on moraine clay. On the average these tests produce results that are only 40% of results obtained by use of homogeneous compression, vane, and plate tests.

Conclusion on plane strain compression tests

In the plane strain compression test smooth platens and height equal to the width ensure homogeneously distributed stresses and strains from the very beginning of the test through failure and after failure. It is as perfect as possible and ideal for investigation of stress-strain relationships with fixed principal directions.

When using fixed ends homogeneous stress and strain distribution can not occur. Some errors arise and in undrained tests on unstable soils as for instance preconsolidated clay the shear strength is determined much too low.

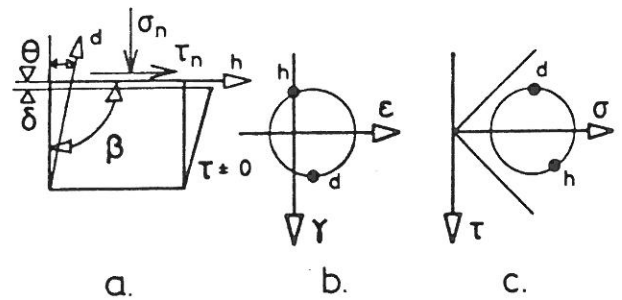

Fig. 7 Normal shear test

In extension tests the narrow failure zone can not be prevented.

SHEAR TESTS

In a plane shear apparatus the specimen is confined by rough, rigid plates. Two opposite sides are prevented from moving in order to ensure plane strains. Fig. 7 shows that the angle between the two other surface planes β is 90° at the beginning of the test. The top plate is allowed to move freely between the side plates and the vertical deformation δ can be measured. At the beginning of the test the normal stress σ_n is applied at the top plate and then kept constant. During the test the shear stress τ_n increases and the rotation θ of the side plates is measured. The stresses σ_t and τ_t at the side plates can be measured too.

The use of a shear apparatus would imply rotating principal directions. But it is normally not possible to obtain homogeneously distributed stresses and strains.

On Fig. 7b and c is shown the Mohr circle for an intermediate state. The shortening in the horizontal direction is prevented (point h) but along the side plates some strains occur (point d). The relative movement between the surface of the specimen and the side plates grows from zero at the bottom of the specimen to a certain value at the top. This will influence the amount of shear stress, which cannot be homogeneously distributed.

A homogeneously strain and stress state is, nevertheless, possible at failure in two different test procedures, but it can not be achieved before failure.

A homogeneous state is already shown on Fig. 4b. The element has $\epsilon = 0$ at the surface corresponding to rigid plates. Since the deformation is from rhomb to square, the specimen should be

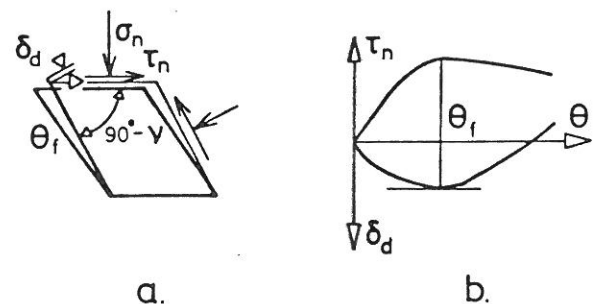

Fig. 8 Pure shear

Discussion on laboratory methods

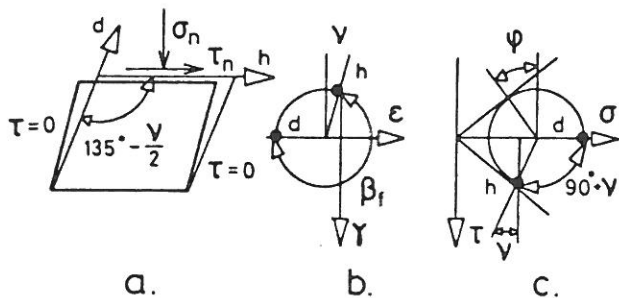

Fig. 9 Simple shear

prepared with $\beta < 90 - v$ and the sides be raised to vertical during the test. The strain along the side plate δ_d should be zero, when the shear strength τ reaches its maximum value. (Fig. 8)

If the two side plates are smooth, their orientation define principal directions. At failure a homogeneous state can be achieved if $\beta = 135^\circ - v/2$ (Fig. 9). The specimen should then be prepared with $\beta < 135^\circ - v/2$ and the sides laid down during testing. When τ takes its maximum value, β should be $135^\circ - v/2$ and δ_d equal to zero.

The Mohr's circles show that the deformations in the two test types are different. At pure shear (Fig. 8) the rotation rate at failure $\dot{\theta}_f$ is twice the distortion rate $\dot{\gamma}$. At simple shear (Fig. 9) $\dot{\theta}_f = \dot{\gamma}_f$. The performance curves will be different, but the failure value of τ_n would be the same. For a cohesionless material the friction angle can be found from Fig. 9c:

$$\frac{\tau_n}{\sigma_n} = \frac{\sin\phi \cos v}{1 - \sin\phi \sin v}$$

AXI-SYMMETRICAL TESTS

In triaxial tests with smooth platens and $H = D$ homogeneous stress and strain distribution is possible. The state of stresses and strains is axi-symmetrical and therefore results must be corrected before use in two-dimensional cases. For instance the friction angle ϕ_{tr} should be increased by at least 10%. In triaxial tests with $H = 2D$ a failure surface may develop. Fig. 6 can be used to illustrate the problem. The failure surface is plane and in principle the parameters correspond to the plane state. However, the development of a failure surface is progressive and the soil strength reduced. The result cannot be related to a specific strain state.

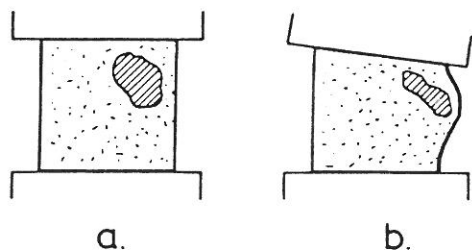

Fig. 10 Heterogeneous specimen

HETEROGENEOUS SOIL

In heterogeneous soil the use of a thin rubber membrane increase the importance of a weak region in the specimen (Fig. 10a and b), since it is possible for the failure to occur here. Stiff plates on the vertical sides would have rearranged the stresses and test results would then nearly describe the average behaviour of the soil. So in that case it seems more reasonable to let rigid plates surround the specimen.

USE OF LABORATORY TESTING IN ENGINEERING PRACTICE

Laboratory tests are used to obtain design parameters, which should be used to predict ground movements or to calculate safety against failure for foundations, natural slopes, excavations, retaining walls etc. In all cases the specific mechanism of ground movement must be considered. If the strain field is continuous as for instance beneath foundations laboratory tests with homogeneously distributed strains must be used to investigate the behaviour of every little part of the soil mass.

This paper recommends compression tests - plane or triaxial - with smooth pressure heads and equal height and diameter of the specimen. For practical purposes other tests may be used as for instance oedometer tests or plane shear tests with small sample heights. In this case the strain state is nearly homogeneous.

Stability problems and developments of failure in slopes or excavations include discontinuous strain fields. Failure takes place in very narrow zones and it is therefore obvious to use laboratory tests where failure surfaces are induced (Fig. 6). However, geometry of failure zones in the test and in the nature are unknowns and hence the ground movement can not be predicted. In unstable soils failure develops progressively and the total length of the failure line plays an important role. In that case it seems more reasonable to use reduced parameters.

REFERENCES

Hansen, Bent (1961). Shear box tests on sand. 5th Int. Conf. on Soil Mech. and Found. Eng. Paris Vol 1, 127-131.

Hansen, Bent (1979). Definition and use of friction angles. 7th Eur. Conf. on Soil Mech. and Found. Eng. Brighton.

Jacobsen, H. Moust (1967). The undrained shear strength of preconsolidated boulder clay. Geotechn. Conf. Oslo.

Roscoe, K.H., Basset, R.H. and Cole, E.R.L. (1967). Principal axes observed during simple shear of sand. Geotechn. Conf. Oslo. Vol 1, 231-237.

Hambly, E.C., Roscoe, K.H. (1969). Observations and predictions of stresses and strain during plane strain of "wet" clay. 7th Int. Conf. on Soil Mech. and Found. Eng. Mexico. Vol. 1, 173-181.

Roscoe, K.H. (1969). New laboratory methods of investigating soil behaviour. Speciality Session on the 7th Int. Conf. on Soil Mech. and Found. Eng. Mexico. Vol. 3, 517-537.