



AALBORG UNIVERSITY
DENMARK

Aalborg Universitet

Determination of the deformation properties of Søvind Marl

Grønbech, Gitte; Nielsen, Benjaminn Nordahl; Ibsen, Lars Bo

Publication date:
2010

Document Version
Publisher's PDF, also known as Version of record

[Link to publication from Aalborg University](#)

Citation for published version (APA):
Grønbech, G., Nielsen, B. N., & Ibsen, L. B. (2010). *Determination of the deformation properties of Søvind Marl*. Department of Civil Engineering, Aalborg University. DCE Technical reports No. 89

General rights

Copyright and moral rights for the publications made accessible in the public portal are retained by the authors and/or other copyright owners and it is a condition of accessing publications that users recognise and abide by the legal requirements associated with these rights.

- ? Users may download and print one copy of any publication from the public portal for the purpose of private study or research.
- ? You may not further distribute the material or use it for any profit-making activity or commercial gain
- ? You may freely distribute the URL identifying the publication in the public portal ?

Take down policy

If you believe that this document breaches copyright please contact us at vbn@aub.aau.dk providing details, and we will remove access to the work immediately and investigate your claim.

Determination of the deformation properties of Søvind Marl

Gitte Lyng Grønbech
Benjaminn Nordahl Nielsen
Lars Bo Ibsen

Aalborg University
Department of Civil Engineering
Geotechnical Engineering Group

DCE Technical Report No. 089

Determination of the deformation properties of Søvind Marl

by

Gitte Lyng Grønbech
Benjaminn Nordahl Nielsen
Lars Bo Ibsen

Month 2010

© Aalborg University

Scientific Publications at the Department of Civil Engineering

Technical Reports are published for timely dissemination of research results and scientific work carried out at the Department of Civil Engineering (DCE) at Aalborg University. This medium allows publication of more detailed explanations and results than typically allowed in scientific journals.

Technical Memoranda are produced to enable the preliminary dissemination of scientific work by the personnel of the DCE where such release is deemed to be appropriate. Documents of this kind may be incomplete or temporary versions of papers—or part of continuing work. This should be kept in mind when references are given to publications of this kind.

Contract Reports are produced to report scientific work carried out under contract. Publications of this kind contain confidential matter and are reserved for the sponsors and the DCE. Therefore, Contract Reports are generally not available for public circulation.

Lecture Notes contain material produced by the lecturers at the DCE for educational purposes. This may be scientific notes, lecture books, example problems or manuals for laboratory work, or computer programs developed at the DCE.

Theses are monographs or collections of papers published to report the scientific work carried out at the DCE to obtain a degree as either PhD or Doctor of Technology. The thesis is publicly available after the defence of the degree.

Latest News is published to enable rapid communication of information about scientific work carried out at the DCE. This includes the status of research projects, developments in the laboratories, information about collaborative work and recent research results.

Published 2010 by
Aalborg University
Department of Civil Engineering
Sohngaardsholmsvej 57,
DK-9000 Aalborg, Denmark

Printed in Aalborg at Aalborg University

ISSN 1901-726X
DCE Technical Report No. 089

Determination of the deformation properties of Søvind Marl

Gitte Lyng Grønbechⁱ Benjamin Nordahl Nielsenⁱⁱ Lars Bo Ibsenⁱⁱⁱ

June 9th 2010

Abstract

A serie of tests were made to determine the preconsolidation stresses, σ'_{pc} , and the consolidation modulus, K , of Søvind Marl, a fissured plastic tertiary clay. The fissures causes a decrease in the stiffness of the Søvind Marl, which can be mistaken for the decrease that happens when the effective stresses in the soil, σ' , passes σ'_{pc} . The effects of the fissures are assessed, and an estimate of the stress level at which they will compress are made. During the consolidation tests, the effective stress level is raised to more then 24,000 kPa to get a comprehensive description of the preconsolidation of the soil.

It is important to know how a strongly preconsolidated soil will deform when reloaded. The deformation parameters of the strongly preconsolidated Søvind Marl is determined by unloading/reloading testing. It is found that the stiffness of the Søvind Marl depends of the plasticity index, and one conclusive expression of the consolidation modulus of the Søvind Marl can therefor not be given.

Keywords: Fissured clay, Søvind Marl, Preconsolidation Stress, Consolidation modulus, Plasticity index

1 Introduction

In Århus, Denmark urban development of new areas is planed, among other places is the old harbor. The harbor is placed directly on a plastic tertiary clay, Søvind Marl. The geotechnical properties of Søvind Marl is fairly unknown. It is therefor interesting to test the stiffness of the Søvind Marl, to gain knowledge that can be used to estimate the deformations large buildings in the area will have to sustain during their

lifetime.

In many cases the parameters are estimated on the classification of the soil. For clays it is however most often necessary to test the soil in order to get a sufficient description of the deformation parameters. This is done by a consolidation test. Some of the most relevant parameters found by using the consolidation test is the consolidation modulus, K , the compression index, Q , the preconsolidation stresses, σ'_{pc} and the in situ consolidation modulus for a strongly preconsolidated clay, K_t .

A description of Søvind Marl can be found in *Comparison of Plasticity Index of Søvind Marl found by use of Casagrande Cup, Fall Cone apparatus and Loss on Ignition* [Grønbech et

ⁱGraduate Student, Dept. of Civil Engineering, Aalborg University, Sohngaardsholmsvej 57, 9000 Aalborg, Denmark

ⁱⁱAssistant Professor, Dept. of Civil Engineering, AAU

ⁱⁱⁱProfessor, Dept. of Civil Engineering, AAU

al., 2010].

6 consolidation tests have been made to determine the deformation properties of the Søvind Marl. 2 tests with only increasing load to determine σ'_{pc} , and 4 consolidation tests where the Søvind Marl was unloaded and reloaded to determine the stiffness parameters during a reloading process.

Through handling and observing the Søvind Marl it was found to be very fissured, as seen in figure 1. It is wanted to see how this effects the stiffness of the Søvind Marl and the determination of σ'_{pc} .



Figure 1: Fissured Søvind Marl after a consolidation test.

2 Theory

Soils are classified by the overconsolidation ratio, OCR , equation 1, which is the ration between the preconsolidation stress, σ'_{pc} , and the present stress level, σ'_0 . A soils deformability depends greatly on the consolidation history. It is therefor important to be able to determine the preconsolidation stress.

$$OCR = \frac{\sigma'_{pc}}{\sigma'_0} \quad (1)$$

When a clay is loaded, the increase in pressure will be carried by the pore water, as an excess pressure in the pores, since the low permeability of the clay will stop the pore water from dissipating. This causes an increase in the total stresses, whereas the effective stresses are unchanged. With time the pore water dissipates, and the pressure is gradually carried by the clay structure, causing an increase in the effective stresses. A simplified system can be seen in figure 2

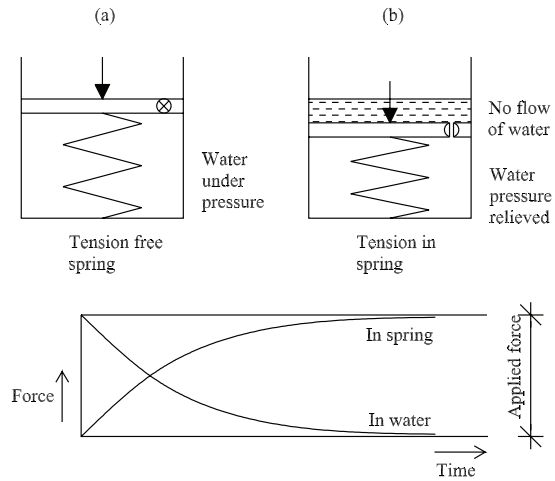

Figure 2: Principle of the classical consolidation theory. After [Thøgersen, 2001]

The valve acts as the permeability and stops the water from dissipating, causing the force to be held by the water pressure (a). When the valves opens, the water dissipates, and the spring, acting as the clay structure, takes the force and compresses (b). When the water has dissipated and the pressure is fully taken by the clay, the system is in equilibrium and the clay is fully consolidated.

The deformation of the clay does not stop, when the clay is fully consolidated, a small deformation continues with time. This deformation is called creep and involves factors as rearranging of particles, absorbed water molecules and cation into different positions.

In the traditional consolidation theory consolidation and creep is considered two separate processes, where the creep does not start until the consolidation is over. The strain caused by consolidation can be described as a straight line when illustrated in a $\sqrt{t}-\varepsilon_1$ graph, while the strain from creep can be described as a straight line in a $\log(t)-\varepsilon_1$ graph. A combination of these two graphs can thereby be used to determine the consolidation time, t_c , the strain caused by consolidation, ε_{100} , and the strain caused by creep, ε_{cr} . An example of an $\sqrt{T}-\log(T)$ depiction from Søvind Marl can be seen in figure 3 where T is a dimensionless time.

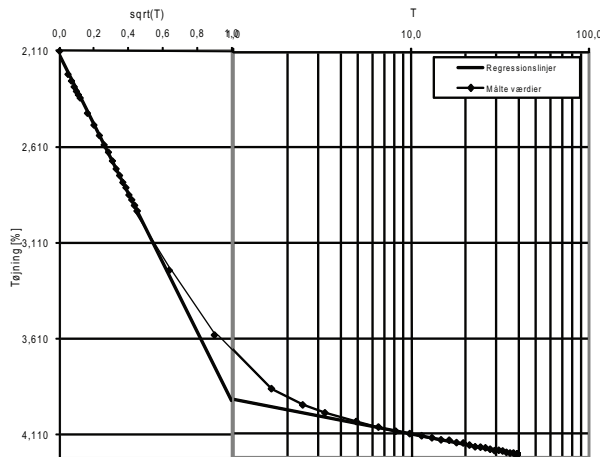

Figure 3: $\sqrt{T}-\log(T)$ depiction of step 7 from sample 840b, table 2.

In reality the consolidation and the creep processes run simultaneously. Bjerrum suggested in 1967, that the two processes are independent of each other. He suggested that by considering the consolidation strains to happen momentarily, the creep strains, ε_{cr} , could be found. Afterwards the consolidation strains, ε_{100} , could be found as a delay in the settlements [Jacobsen, 1993]. The separation of the strains from respectively consolidation and creep can be seen in figure 4.

This theory is used by the ANACONDA-

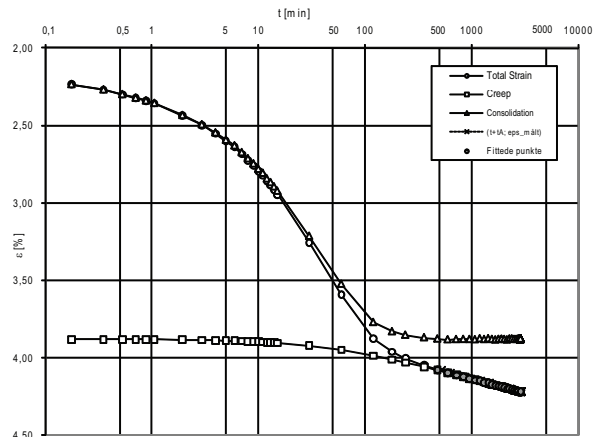

Figure 4: Separation of strain from consolidation and creep from of step 7 from sample 840b.

method, which is used to analyse the results in this paper. [ANACONDA, 1992]

It is important to be able to estimate the strains, that will occur when the effective stresses in a soil increases. The consolidation modulus, K , is a stiffness parameter that describes the increase in strains when the effective stresses increases. The consolidation modulus is described as:

$$K = \frac{\Delta\sigma'}{\Delta\varepsilon} \quad (2)$$

where $\Delta\varepsilon$ is the changes in the consolidation strains due to a change in the effective stresses, $\Delta\sigma'$. It is therefore important to be able to sort the consolidation strains from the creep strains. This is done either by the traditional method, figure 3, or by the ANACONDA-method, figure 4.

2.1 Preconsolidation stress

Janbu (1970) showed that by observing the relation between K and σ' , figure 5, it can

be seen that a significant change occurs to K when σ' passes σ'_{pc} . This is due to the fact that the stiffness of the soil decreases as the preconsolidation state is passed, because the structure of the soil changes.

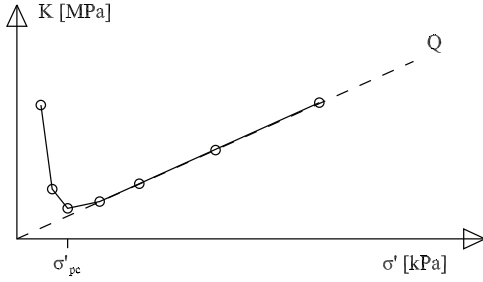

Figure 5: The relation between the consolidation modulus, K , and the effective stresses, σ' .

σ'_{pc} can hereby be determined as the effective stresses, where a drop occurs in K .

2.2 Unload and reloading

For a strongly preconsolidated soil, the stresses have been much greater than the in situ stresses, it has therefore been unloaded. When a construction is built the stresses in the underlying soil will rise. This is a reloading of the soil. To determine how the soil will deform under reloading, the soil is unloaded and reloaded during the consolidation test.

The consolidation modulus for a strongly preconsolidated soil which has been unloaded to σ'_{red} is given by [Danish Geotechnical Society, 2001]:

$$K_t = K_{t0} + \Delta K_t \cdot \sigma'_{red} \quad [\text{kPa}] \quad (3)$$

where K_t is the in situ consolidation modulus for a strongly preconsolidated soil unloaded to σ'_{red} , which is the smallest vertical stresses since the preconsolidation of the soil. ΔK_t is an addition to K_t per stress unit.

When unloading the sample during testing, the stresses are reduced. Using this stress level as σ'_{red} , the initial slope of the reloading branch in the point of σ'_{red} is found, figure 6. K_t can now be found as the inverse to the slope. σ'_{red} is known as the lowest stress level in the reloading series. This gives 2 unknown in equation 3, K_{t0} and ΔK_t . With 2 reloading branches, linear algebra can now be used to find K_{t0} and ΔK_t .

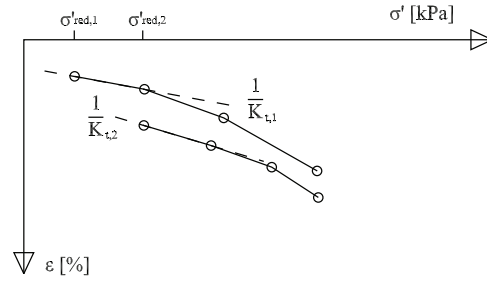

Figure 6: The initial slope for the reloading branch in σ'_{red} .

3 Procedure

The consolidation tests are made in a Danish Consolidation Apparatus. The apparatus consists of a cell with the soil sample, figure 7, and a rig with a lever arm pressing with a load ratio of 1:10. The cell consists of a stiff ring, where the sample is placed. A porous filter in the cap and the base makes sure the sample is able to drain. The ring floats and is only held by the friction between the ring and the sample. In the tests two different rings with a diameter of respectively 70 mm and 35 mm were used, the sample height in both cases was 35 mm. The porous filters had a diameter corresponding to the diameter of the sample. The displacements are measured by two transducers with a measuring range of ± 10 mm. The load is applied by placing weights on the lever arm, which transmit the pressure through the ball.

The sample is placed in the ring and adjusted

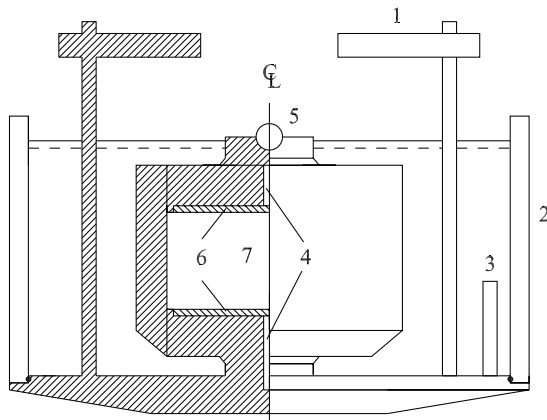

Figure 7: Danish Consolidation Apparatus. 1: Stand for transducer, 2: Ring of plexiglass, 3: Saturation pipe, 4: Pipe for saturating drains, 5: Ball, 6: Porous filter and 7: Sample. Dimensions are not accurate. After [Thøgersen, 2001]

to the right hight, and both ends are leveled. After placing the cell in the apparatus and placing the transducers, initial weight is places on the lever arm. After 1 minut water is filled around the cell, to ensure the sample is saturated during the entire test.

The Chloride concentration and pH of the pore water is tested prior to the tests, and a Saline solution with a Chloride concentration and a pH similar to the pore water is used. This is done, so the difference in the ion concentration between the pore water and the water surrounding the sample does not cause an osmotic pressure. An osmotic pressure would interfere with the pressure caused by the applied load and give inaccurate displacements. [Thøgersen, 2001]

The load is applied in increments, when the consolidation phase of the previous load step is over. It is crucial that the consolidation phase is done before new load is applied, otherwise it will affect the outcome of the test. A computer logs the displacements and the time that has passed since the beginning of the step, enabling a \sqrt{t} - $\log t$ depiction, figure 3, to be made, en-

suring that the consolidation phase is done.

3.1 Sample diameter

The stress applied on the sample depends on the area of the sample and the applied load. A decreased area results in an increased stress under constant load. The consolidation apparatus used had a maximum load capacity of 250 kg. With a 1:10 load rasion and a diameter of 70 mm, this corresponds to an applied maximum stress of around 6,500 kPa. By decreasing the diameter to 35 mm the maximum stress quadruples to 26,000 kPa. Using a smaller sample diameter allows testing at much higher stress level, and thereby an more thorough description of the preconsolidation history.

4 Tests

6 consolidation tests are made from varying depths. 4 tests with a sample diameter of 70 mm and a sample hight of 35 mm, these tests were done as unload/reloading tests. To document the preconsolidation stresses, 2 consolidation tests with a sample diameter of 35 mm and a sample hight of 35 mm were made. The sample number, informations on the samples and the used Saline solution can be seen in table 1.

The load series used can be seen in table 2. The underlined steps are unloading steps. For sample 820 and 840, there is an extra step between step 7 and 8 with a stress level of 486.2 kPa, this is to minimize the difference in load applied from σ'_{insitu} to the stresses at step 8.

The compression curve for the tests can be seen in figure 8.

Table 1: Number and information on the samples and the used Saline solutions.

Name	Depth [m]	Diameter [mm]	$\sigma'_{in-situ}$ [kPa]	w_{before} [%]	w_{after} [%]	γ' [$\frac{kN}{m^3}$]	I_P [%]	pH	Cl^- [%]
820	31	70	284	45.5	29.6	8.1	121.3	9.31	0.3
840	39	70	348	34.3	29.7	8.7	132.2	9.17	0.3
895	61	70	516	36.7	34.1	8.1	175.3	9.20	0.3
905	65	70	548	42.6	34.5	8.0	263.2	9.19	0.3
840a	39	35	348	34.6	21.5	8.6	132.2	9.20	0.5
840b	39	35	348	36.0	21.3	8.4	132.2	9.20	0.5

Table 2: Load steps uses for consolidation tests. Underlined steps are unloading steps.

Diameter 70 mm						Diameter 35 mm	
Step	σ' [kPa]	Step	σ' [kPa]	Step	σ' [kPa]	Step	σ' [kPa]
1	26.9	12	3037.9	23	2527.5	1	56.0
2	52.4	<u>13</u>	2527.5	24	3037.9	2	107.0
3	103.4	<u>14</u>	2017.2	25	3548.2	3	209.1
4	231.0	<u>15</u>	1506.9	26	4058.5	4	413.2
5	486.2	<u>16</u>	996.5	27	4568.9	5	821.5
6	741.4	17	1506.9	28	5079.2	6	1535.9
<u>7</u>	σ'_{insitu}	18	2017.2	29	5589.5	7	3067.0
8	996.5	19	2527.5	-	-	8	6129.0
9	1506.9	20	3037.9	-	-	9	12253.0
10	2017.2	<u>21</u>	2527.5	-	-	10	18377.0
11	2527.5	<u>22</u>	2017.2	-	-	11	24501.0

The compression curve becomes a straight line when $\sigma'_{pc} < \sigma'$. The compression curve for sample 840, 895 and 905 do not appear to end in a straight line. This suggest that σ'_{pc} might not be exceed, and can therefor not be determined by these tests. The compression curve for sample 820 follows the other curves until σ' passes σ'_{insitu} . Hereafter the slope of the curve becomes very steep. This suggest that something went wrong during the test, which effects the results. It is therefor chosen to disregard these results in the further analysis of the Søvind Marl.

The compression curve for sample 840a and 840b appears to become a straight line around

step 8, at an effective stress level of 6129 kPa, suggesting that σ'_{pc} is exceeded around this point. Step 11 is not located on the straight line. This is because the total deformation of the sample is too great for the conventional linearly method of finding the strains, which is found as the deformation in regards to the initial hight of the sample, 35 mm.

The samples 840, 840a and 840b all come from the same depth, but 840a and 840b appears to have a higher stiffness then 840. The friction between the ring and the sample have a greater impact on the deformation when the hight is equal the diameter of the sample. This results in higher deformations, when the hight is only

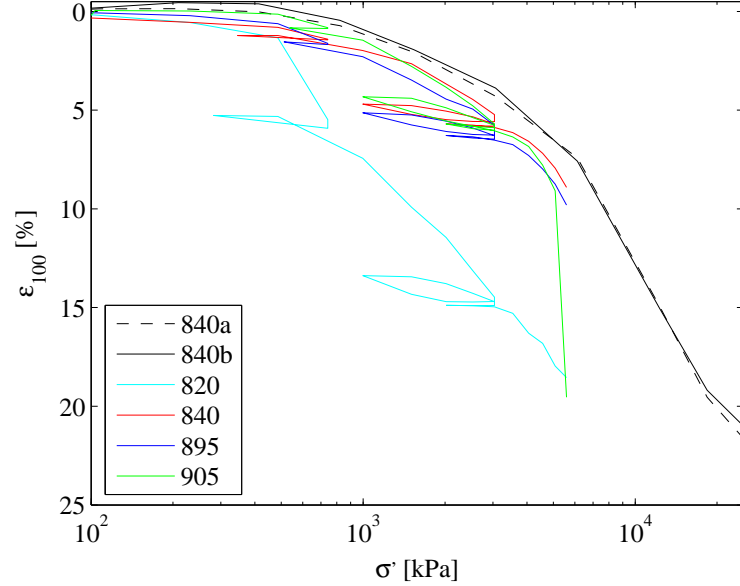

Figure 8: Compression curves for the 6 test series.

half the diameter. The effect of the friction is minimized by using a floating ring as described in section 3.

4.1 Preconsolidation stress

Using the consolidation modulus curve, the preconsolidation stress is defined as σ' correlating to the point where a drop in K has occurred, and σ' starts to follow a straight line with an incline corresponding to the compression index, Q , figure 5.

The consolidation modulus for the 2 test with a diameter of 35 mm can be seen in figure 9. σ'_m is the mean of the previous and the following stress level.

When observing the consolidation modulus curves in figure 9, it can be seen that the consolidation modulus, K , dependent on σ'_m decreases around $\sigma'_m = 617$ kPa for both samples. Here after K starts to increase as de-

scribed by Janbu (1970). K increases till σ'_m reaches 4600 kPa, where another drop occurs in K . For σ'_m equals 9191 kPa K again increases following a straight line with a slope expresses by the compression index, Q . As it was the case for the compression curve, step 11, σ'_m equals 21400 kPa, stray from what was expected. This is also because of the limitations of the theory.

The double decrease in K happens because the Søvind Marl is fissured. During the loading process the fissures closes, which causes deformations of the sample. These deformations causes a reduction of the stiffness of the Søvind Marl, making the consolidation modulus drop. The deformations caused by the fissures are not caused by a consolidation phase, but the theory interprets the deformations as a restructuring of the clay particles, as if the preconsolidation stresses were exceeded.

The preconsolidation stresses is therefor the effective stresses at the second drop, where K

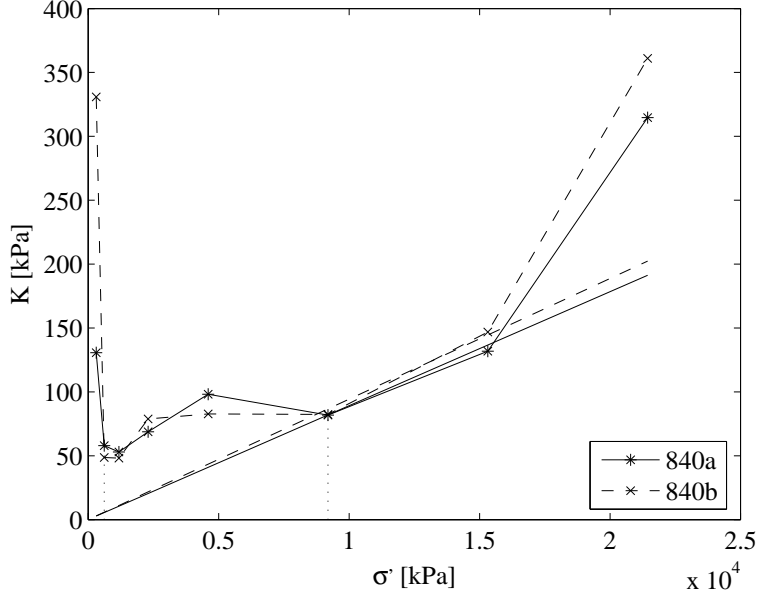

Figure 9: Consolidation modulus curve for the 2 test series with a diameter of 35 mm. The dotted lines represents σ'_f and σ'_{pc} .

starts to follow the straight line with the incline corresponding to Q . The preconsolidation stresses, σ'_{pc} , the effective stresses where the fissures closes, σ'_f , and the compression index, Q , can be seen in table 3.

Table 3: The preconsolidation stresses and the stresses at which the fissures closes, found using the consolidation modulus.

Name	σ'_f [kPa]	σ'_{pc} [kPa]	Q [%]
840a	617.3	9191.0	25.8
840b	617.4	9191.0	24.4

4.2 Reloading

The reloading branches of the compression curves from test 840, 895 and 905 can be seen in figure 10.

K_t as a function of σ'_{red} can be seen in figure 11. K_t is the inverse of the slope between the

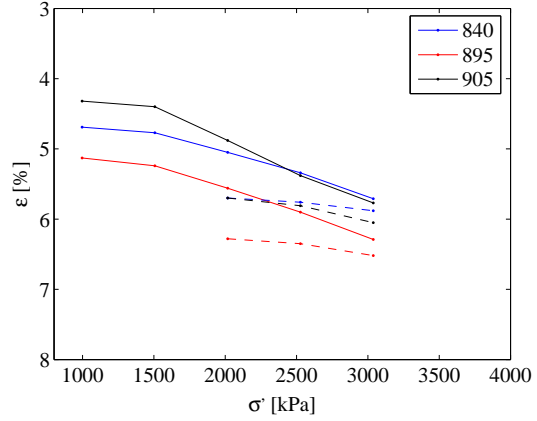

Figure 10: Reloading branches, the solid lines are the 1st reloading branch, and the dashed lines are the 2nd.

first two steps of the reloading branch. It is seen, that this gives a faulty description of K_t since the incline of 840 and 905 is negative, which is physically impossible, as the stiffness of the Søvind Marl should then decrease with an increasing σ'_{red} .

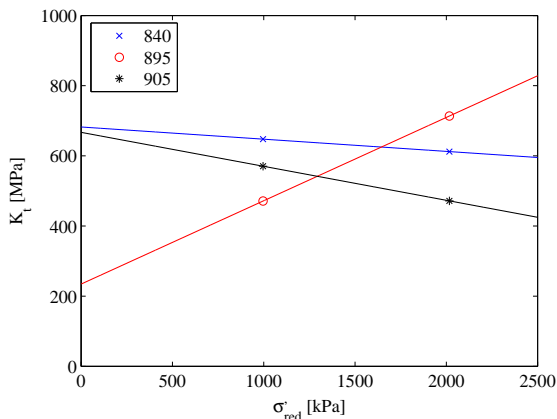

Figure 11: K_t as a function of σ'_{red} . K_t is found using the first 2 steps of the reloading branch.

The load difference between the steps are 500 kPa, and the difference in deformation is relativ small. This gives an uncertainty about the found K_t . This uncertainty is minimized by using the slop of the first three points of the reloading branch to determine K_t , which appears to give a better description of the stiffness of the Søvind Marl, figure 12. The description of 840 is forced to intersect $\sigma_{red} = 0$ at the same spot as 895 and 905, as it is believed that this gives the best description of K_t .

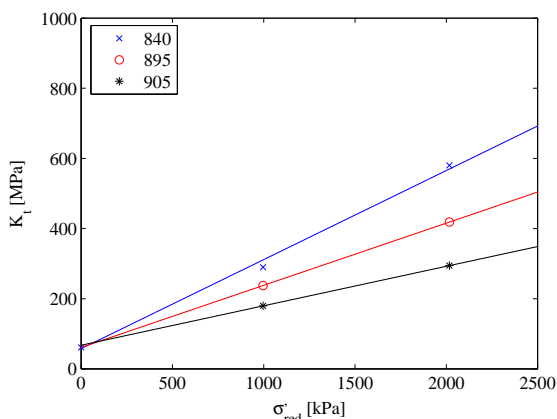

Figure 12: K_t as a function of σ'_{red} . K_t is found using the first 3 steps of the reloading branch.

K_t and σ'_{red} used in figure 12 can be seen in table 4, along with ΔK_t and K_{t0} , equation 3, found for 840, 895 and 905.

It is known that the stiffness of a clay is inversely proportional to the plasticity of the clay. The relation between ΔK_t and I_P can be seen in figure 13. I_P can be seen in table 1.

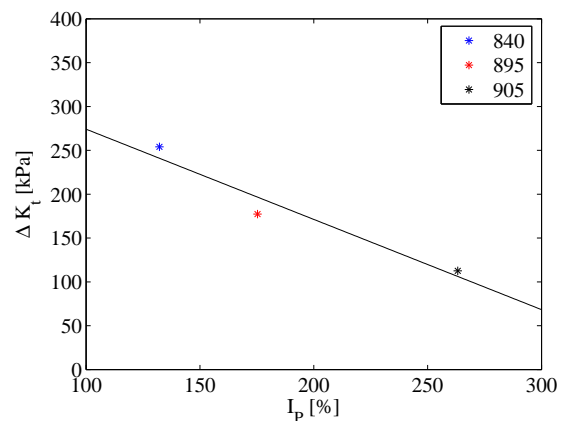

Figure 13: ΔK_t as a function of I_P .

A relation between ΔK_t and I_P is seen. The relation for Søvind Marl can be described as:

$$\Delta K_t = 377.0 - 1.03 \cdot I_P \quad (4)$$

ΔK_t is decreasing with an increasing plasticity index. One solution to equation 3 can therefor not be given, as the stiffness of the Søvind Marl depends on I_P , which has large variations as shown by Grønbech et al. 2010.

5 Discussion

When interpreting a consolidation test, it is important to separate the consolidation strains, ε_{100} , and the creep strains, ε_{cr} , since only ε_{100} is used in the analysis of the results.

Table 4: K_t and σ'_{red} used to find ΔK_t and K_{t0} from equation 3.

	Reloading branch	σ'_{red} [kPa]	K_t [Mpa]	ΔK_t [kPa]	K_{t0} [Mpa]
840	1 st	996.5	289.9	254.0	57.51
	2 nd	2017.2	580.0		
895	1 st	996.5	237.6	177.3	60.95
	2 nd	2017.2	418.5		
905	1 st	996.5	179.5	112.6	67.31
	2 nd	2017.2	294.3		

It is therefore important to ensure that the consolidation phase of each load step is over, prior to starting a new step. If the consolidation phase is not over, ε_{100} is not fully developed, causing a wrongful separation of ε_{100} and ε_{cr} . This will give a wrong analysis of the deformation properties. Through experience from the tests on the Søvind Marl, it was found that each step should last for a period of the least 2 days before the consolidation strains could be determined. Steps lasting for a smaller period will not be fully consolidated, which can result in an inaccurate analysis of the stiffness of the Søvind Marl.

The steps in the load series of a consolidation test should be chosen carefully, and with the result in mind. The bigger the steps, the more inaccurate the results can be determined due to the large difference in stresses, and if the steps are too small and left for too long, the creep strains will pass the consolidation stresses for the following load step.

As shown by the tests a decrease in the stiffness of the clay can occur when the clay is fissured. If the consolidation test is stopped before the preconsolidation stresses are exceeded, the decrease in stiffness caused by the fissures can wrongfully be used to determine σ'_{pc} . It is however, also important to know at which effective stress level, σ'_f , a decrease in the stiffness caused by fissures can occur, since this

affects the strength of the clay in a way similar to the decrease in stiffness that occur when σ'_{pc} is exceeded.

ΔK_t , and thereby K_t , for the strongly preconsolidated Søvind Marl is found to be dependent on the plasticity index. The stiffness of the Søvind Marl is decreasing with an increasing I_P . This should be considered when using K_t . One conclusive expression for K_t , equation 3, through the depth of the Søvind Marl can therefore not be used. A description of I_P through the depth of the Søvind Marl is required in order to estimate ΔK_t , and thereby K_t .

6 References

Anaconda manual 2.22, 1992

Danish Geotechnical Society, 2001, Manual for laboratory tests, Aalborg

Grønbech, Gitte Lyng and Ibsen, Lars Bo and Nielsen, Benjaminn Nordahl, 2010, Comparison of Plasticity Index of Søvind Marl found by use of Casagrande Cup, Fall Cone apparatus and Loss on Ignition, Aalborg University

Jacobsen, Moust, 1993, Lærebog i vidergående geoteknik 2, Sætninger i jord, Aalborg University

Janbu, Nilmar, 1970, Grunnlag i geoteknikk,
Tapir Forlag

Thøgersen, Lotte, 2001, Effects of Experimental Techniques and Osmotic Pressure on the Measured Behavior of Tertiary Expansive Clay, Vol. 1, Aalborg University

Recent publications in the DCE Technical Report Series

DCE Technical Report No. 087, Comparison of Plasticity Index of Søvind Marl found by use of Casagrande Cup, Fall Cone apparatus and Loss on Ignition, Gitte Lyng Grønbech, Benjaminn Nordahl Nielsen and Lars Bo Ibsen

DCE Technical Report No. 088, Chloride concentration and pHs influence on the Atterberg limits of Søvind Marl, Gitte Lyng Grønbech, Lars Bo Ibsen and Benjaminn Nordahl Nielsen

