



**AALBORG UNIVERSITY**  
DENMARK

**Aalborg Universitet**

## **Reliability Analysis of Timber Structures through NDT Data Upgrading**

*Short Term Scientific Mission, COST E55 Action*

Sousa, Hélder; Sørensen, John Dalsgaard; Kirkegaard, Poul Henning

*Publication date:*  
2010

*Document Version*  
Publisher's PDF, also known as Version of record

[Link to publication from Aalborg University](#)

*Citation for published version (APA):*

Sousa, H., Sørensen, J. D., & Kirkegaard, P. H. (2010). *Reliability Analysis of Timber Structures through NDT Data Upgrading: Short Term Scientific Mission, COST E55 Action*. Department of Civil Engineering, Aalborg University. DCE Technical reports No. 96

### **General rights**

Copyright and moral rights for the publications made accessible in the public portal are retained by the authors and/or other copyright owners and it is a condition of accessing publications that users recognise and abide by the legal requirements associated with these rights.

- ? Users may download and print one copy of any publication from the public portal for the purpose of private study or research.
- ? You may not further distribute the material or use it for any profit-making activity or commercial gain
- ? You may freely distribute the URL identifying the publication in the public portal ?

### **Take down policy**

If you believe that this document breaches copyright please contact us at [vbn@aub.aau.dk](mailto:vbn@aub.aau.dk) providing details, and we will remove access to the work immediately and investigate your claim.

# **Reliability analysis of timber structures through NDT data upgrading**

Short Term Scientific Mission, COST E55 Action

**Hélder Sousa, John Dalsgaard Sørensen,  
Poul Henning Kirkegaard**



**AALBORG UNIVERSITY**

**Department of Civil Engineering**

**ISSN 1901-726X  
DCE Technical Report No. 96**

Aalborg University  
Department of Civil Engineering  
Division of Structural Mechanics

**DCE Technical Report No. 96**

# **Reliability analysis of timber structures through NDT data upgrading**

by

Hélder Sousa, John Dalsgaard Sørensen, Poul Henning Kirkegaard

© Aalborg University 2010.

## **Scientific Publications at the Department of Civil Engineering**

*Technical Reports* are published for timely dissemination of research results and scientific work carried out at the Department of Civil Engineering (DCE) at Aalborg University. This medium allows publication of more detailed explanations and results than typically allowed in scientific journals.

*Technical Memoranda* are produced to enable the preliminary dissemination of scientific work by the personnel of the DCE where such release is deemed to be appropriate. Documents of this kind may be incomplete or temporary versions of papers—or part of continuing work. This should be kept in mind when references are given to publications of this kind.

*Contract Reports* are produced to report scientific work carried out under contract. Publications of this kind contain confidential matter and are reserved for the sponsors and the DCE. Therefore, Contract Reports are generally not available for public circulation.

*Lecture Notes* contain material produced by the lecturers at the DCE for educational purposes. This may be scientific notes, lecture books, example problems or manuals for laboratory work, or computer programs developed at the DCE.

*Theses* are monographs or collections of papers published to report the scientific work carried out at the DCE to obtain a degree as either PhD or Doctor of Technology. The theses are publicly available after the defence of the degree.

*Latest News* is published to enable rapid communication of information about scientific work carried out at the DCE. This includes the status of research projects, developments in the laboratories, information about collaborative work and recent research results.

Published 2010 by  
Aalborg University  
Department of Civil Engineering  
Sohngaardsholmsvej 57,  
DK-9000 Aalborg, Denmark

Printed in Aalborg at Aalborg University

ISSN 1901-726X  
DCE Technical Report No. 96

## ACKNOWLEDGEMENTS

The work described in this report was conducted at Aalborg University, Denmark as a part of the COST Action E55 “Modelling of the performance of timber structures”. Financial support provided by COST Action E55 is gratefully acknowledged.

The financial support of the Portuguese Science Foundation (Fundação de Ciência e Tecnologia, FCT), through project SFRH/BD/62326/2009, is gratefully acknowledged.

This work was carried out at Aalborg University during the period from April to June 2010. This institution provided an excellent working environment and its support is highly acknowledged.

This work was carried out with the support of many individuals.

I would like to express my thanks to Prof. John D. Sørensen and Prof. Poul H. Kirkegaard for their support and assistance. The numerous meetings were of extreme importance and provided invaluable information. I gratefully acknowledge those opportunities for interchange of ideas and knowledge.

Also, I express my thanks to my PhD supervisors, Prof. Paulo B. Lourenço and Prof. Jorge G. Branco, who first had the idea for this STSM. Their support and competent guidance are greatly acknowledged.

Last but not least I wish to thank my family and friends for supporting me always with their sympathy and encouragement.

# TABLE OF CONTENTS

1.	INTRODUCTION.....	1
2.	TIMBER STRUCTURES .....	3
2.1	INTRODUCTION .....	3
2.2	HISTORY AND EVOLUTION OF TIMBER STRUCTURES IN EUROPE.....	3
2.3	TIMBER CHARACTERISTICS .....	6
2.4	TIMBER STOCHASTIC MODELS .....	8
2.4.1	Resistance models .....	9
2.4.2	Spatial variability .....	11
2.4.3	Size effect.....	11
2.4.4	Failure types.....	12
2.5	timber pathologies .....	13
2.5.1	Deterioration and damage accumulation models .....	14
2.5.2	Inspection techniques for timber structures .....	17
	Visual inspection .....	17
	Resistograph .....	18
	Pilodyn.....	18
2.5.3	Hygrometer .....	19
3.	RELIABILITY OF STRUCTURES .....	20
3.1	INTRODUCTION .....	20
3.2	SYSTEM RELIABILITY ANALYSIS.....	22
3.2.1	System concepts .....	22
3.2.2	Series systems.....	25
3.2.3	Parallel systems.....	28
3.2.4	Series of parallel systems .....	30
3.2.5	Ductile / Brittle materials influence in systems reliability .....	31
	Ductility/brittleness of components.....	32
	Stochastic dependencies .....	33
	Load and strength variability .....	33
3.3	STOCHASTIC MODELS FOR LOADS .....	34
3.3.1	Permanent and imposed loads.....	35
3.3.2	Live loads.....	35
3.3.3	Snow load .....	36
3.3.4	Wind load .....	36
3.3.5	Limit state equations .....	37
4.	UPDATING METHODS.....	38
4.1	INTRODUCTION .....	38
4.2	UPDATING METHODS CONCEPTS.....	38
4.2.1	Bayesian methods .....	39
4.2.2	Prior, posterior and predictive distributions .....	41
	Example.....	42
4.3	UPDATING BASED ON INSPECTION OF DETERIORATION.....	47
5.	ROBUSTNESS .....	48
5.1	INTRODUCTION .....	48
5.2	FRAMEWORK FOR ROBUSTNESS OF STRUCTURES .....	49
5.3	METHODS TO ASSESS ROBUSTNESS .....	51
5.3.1	Risk-based robustness index.....	51
5.3.2	Reliability-based robustness index.....	53

5.3.3	Deterministic robustness index.....	53
6.	<b>EXAMPLE CASES / STUDY CASES .....</b>	<b>55</b>
6.1	<b>INTRODUCTION .....</b>	<b>55</b>
6.2	<b>EXAMPLE CASE A: SINGLE ELEMENT STRUCTURE.....</b>	<b>55</b>
6.2.1	Design by Eurocodes .....	55
6.2.2	Sensitivity analysis.....	58
6.2.3	Structural life-cycle assessment.....	61
6.2.4	Data updating .....	65
6.2.5	Reliability-based robustness index.....	68
6.3	<b>EXAMPLE CASE B: COLUMN .....</b>	<b>69</b>
6.3.1	Design by Eurocodes .....	69
6.3.2	<b>Data updating .....</b>	<b>70</b>
	Maximum Likelihood method .....	71
	NDT and MDT data.....	71
	Reliability assessment .....	74
7.	<b>CONCLUSIONS .....</b>	<b>76</b>
	<b>REFERENCES .....</b>	<b>78</b>
	<b>ANNEXES.....</b>	<b>81</b>
	Annex A: Different types of prior, posterior and predictive distributions .....	81
	Annex B: t-student distribution .....	89
	Annex C: Data from NDT and MDT.....	90

# 1. INTRODUCTION

The work presented here was conducted within the framework of COST Action E55: “Modelling of the Performance of Timber Structures” during a Short Scientific Mission – STSM – carried out in Aalborg University, Denmark, by PhD student Hélder Sousa from University of Minho, Portugal, with supervision of Professor John Dalsgaard Sørensen and Associate Professor Poul Henning Kirkegaard. This STSM was carried out from April to June, 2010, with reference number COST-STSM-E55-6269.

COST (European Cooperation in Science and Technology) is an intergovernmental framework for coordination of nationally-funded research at a European level. Starting from 1971, it has now the contribution of 34 Member countries including the 27 EU Member States, as well as, Croatia, Iceland, Norway, the Republic of Serbia, FYR of Macedonia, Switzerland and Turkey and also Israel as a cooperating state. Inside COST activities, research networks are defined as Actions, where research institutions from different member countries, cooperating states and even non-COST countries gather in concerted activities for mutual benefit. COST extends its framework to nine key scientific domains, being relevant to this work the “Forests, their Products and Services” – FPS – domain. FPS has the purpose of promoting research throughout the forest-wood-chain by providing a platform for funded research activities in the areas of forestry, wood technology and pulp & paper.

The main objective of Action E55 is to establish basic frameworks and knowledge in order to use timber efficiently and sustainably as a structural and building material. Regarding this objective, focus is directed on design, construction, safety assessment and maintenance aspects mainly for high performance timber structures, where load-bearing capacity is of relevant interest.

A life-cycle assessment of timber structures, in design, construction and monitoring phases, is highly important for a safer and more sustainable use of timber as a building material, also permitting for a better performance and lower costs of maintenance. In search of this higher performance use for timber structures, recent research activities have been proposed, from which several achievements in the field of materials science and structural reliability have been attained, providing a basis for safety assessment and quantification, serviceability, durability and life-cycle costs of structure.

According to those assumptions, Action E55 considered three main research activities: the identification and modelling of relevant load and environmental exposure conditions, the improvement of knowledge concerning the behaviour of timber structural elements and the development of a generic framework for the assessment of the life-cycle vulnerability and robustness of timber structures.

The main purpose of this STSM is to address reliability methods for analysis of timber structures using non-destructive tests – NDT – and minor destructives tests – MDT – results for modelling upgrade of the structural and mechanical characteristics of timber. The probability density functions of timber’s mechanical properties defined in the Probabilistic Model Code [JCSS, 2006] may be upgraded with the results of mechanical tests. However, a grading methodology based in visual inspection associated with NDT and MDT results are also a suitable source of information for an upgrading data model.

The first part of this document presents, in chapter 2, a description of timber characteristics and common used NDT and MDT for timber elements. Stochastic models for timber properties and damage accumulation models are also referred. According to timber’s properties a framework is proposed for a safety reassessment procedure. For that purpose a theoretical background for structural reliability assessment including probabilistic concepts for structural systems and stochastic models are given in chapter 3. System models, both series and parallel systems, are presented as well as methods for reliability calculation. In chapter 4, updating methods are conceptualized and defined. Special attention is drawn upon Bayesian methods and its implementation. Also a topic for updating based in inspection of deterioration is provided. State of the art definitions and proposed measurement indices for robustness are dealt in chapter 5. The second part of this document begins in chapter 6, where a practical application of the premise definitions and methodologies is given through the implementation of upgraded models with NDT and MDT data. Structural life-cycle is, therefore, assessed and



reliability and robustness indices are proposed. The final part of this document presents the conclusions that were found, in terms of results and outcomes, and future perspectives and recommendations for further development and improvements.

## **2. TIMBER STRUCTURES**

### **2.1 INTRODUCTION**

Timber is a rather complex construction material, due to the fact that its mechanical properties are dependent of the direction of the grain – anisotropic behaviour. Moreover, its properties also vary on space and time. For instance, the material properties of a timber element vary both in different parts of the same cross-section as well as along the element itself. Differences are also visible when comparing different timber elements even if they are from the same specie. Therefore, timber structures are particularly suitable for the use of stochastic reliability methods on structural safety evaluation.

Timber is a natural material used in several civil engineering applications either for structural or non-structural purposes. Although its use has decreased due to the emergence of new materials, timber offers many advantages. The production process presents lower energy requests than for other materials, such as metals, alloys or even concrete. Since it is an anisotropic material its full mechanical characterization is rather complex, however when well used it provides a good mechanical behaviour associated to an effective relation between resistance and density. Although many different climatic zones are found around the planet, also different trees' species can be found which have adapted to the prevailing conditions within each climatic zone. Thus, offering a source of construction materials for most inhabited regions of the world.

The field of interest in timber research is not only dedicated to new construction, because timber is present in several ancient and historical monuments all over the globe. Therefore, a better understanding of its performance and durability throughout its expected lifetime may allow a better safety reassessment of existing structures and possible necessary actions to maintain its integrity. In this matter, modelling the characteristics of existing structures may sometimes lead to costly procedures. However, many times the costs of an adequate inspection and monitoring plan are far less inferior to those compared to time inadequate maintenance, repairing interventions or in extreme situations to the consequences of a structural collapse. Concerning historical monuments, semi or non-destructive tests are often used as a useful tool for assessment and deterioration of the structure. The results gathered from these tests may then be used to update stochastic models and therefore providing a stable framework for safety assessment of timber structures.

In this topic, different aspects regarding timber as a building material will be addressed. Firstly, an historic evolution of timber structures in Europe will be regarded. After that, general definitions about the characteristics of timber are given and stochastic resistance models are presented. Descriptions of non-destructive and minor-destructive tests are also found in this topic. At the end, general remarks about design and construction of timber structures are briefly mentioned.

### **2.2 HISTORY AND EVOLUTION OF TIMBER STRUCTURES IN EUROPE**

The history of timber being used as construction material goes back to when the human species first started to employ tools or even farther. Timber structures have evolved through time as the human race necessity grew and also the expertise and knowledge about the material and the interaction between elements in different structural typologies increased. One may only speculate how the first timber constructions were erected but, as many of human kind accomplishments they might have been fruit of a trial and error procedure that was eventually improved and refined. Then the expertise and knowledge was passed from generation to generation, making possible new techniques and bolder solutions. In this work, only some examples will be addressed, generally limited to houses and restricted to the European experience [Kuklík, 2010].

Primeval shelters were constructed during the existence of *Homo sapiens neanderthalensis* (120 000 to 40 000BC) made of a framework from adequate tree branches interlaced by deciduous tree branches or covered by grass. The floor plan of these primeval shelters was circular. From 40 000 to 10 000BC, the early *Homo sapiens sapiens* shelters were constructed from tree branches and covered by hides

with usually elliptical floor plan, and relatively large shelters have been documented. From 4 500BC the first farmers erected the first timber framed houses. However, since the first farmers did not have enough experience in structural detailing and carpentry joints, specially in trusses and bracing, the durability of these houses did not usually exceed a couple of decades. Nevertheless, they constructed the early versions of a timber long-house. The main framework of the long-houses consisted in five lines of logs set in the ground. The logs then gave support to a set of purlins which carried the rafters. The outside lines of the logs were interlaced by deciduous tree branches which were covered by clay. This type of construction was also used by farmers in 3 000BC, although the floor plan started to resemble to a trapezoidal shape. By the year 400BC, Celts constructed light timber houses with a stone pedestal, and this type of house endured in Central and Eastern Europe over the following centuries. When the Roman Empire was in expansion, the territory of Central Europe was mainly occupied by the Teutons which constructed rather primitive and small houses. At the beginning of the Middle Age, older versions of timber houses began to gradually be replaced by log-houses. By the 15<sup>th</sup> century, in forested regions of Central and Eastern Europe a new technique was developed using predominantly round logs laid horizontally on top of each other to form walls. Wall planes were interlocked by notching of the logs at the corner intersections. More sophisticated types of notching were then developed using trimmed logs and dovetail notches at the corners. By the same time in Western Europe and also some parts of Central Europe, the half-timbered house building technique developed using short logs, using inexpensive local materials as nogging. Sometimes a combination of both log-house and half-timbered house were used for structural purposes. From the 16<sup>th</sup> century, town houses were essentially made from masonry. During the 18<sup>th</sup> century, only floors, separating walls and roofs were mainly used, such as in many places timber was prohibited as a construction material due to fire hazard. During the centuries and to the present day, timber as also been used for structural support of roofs above vaults and dooms of many historical monuments, such as churches, cathedrals, universities and others.

Nowadays, due to the evolution of different typologies of wood based materials, such as LVL (laminated veneer lumber), plywood or glulam (glued laminated timber), timber may be used efficiently in structures where large spans and high load-bearing capacity of elements are requested. A chronological time line with some timber constructions examples may be seen in Figure 2.1.

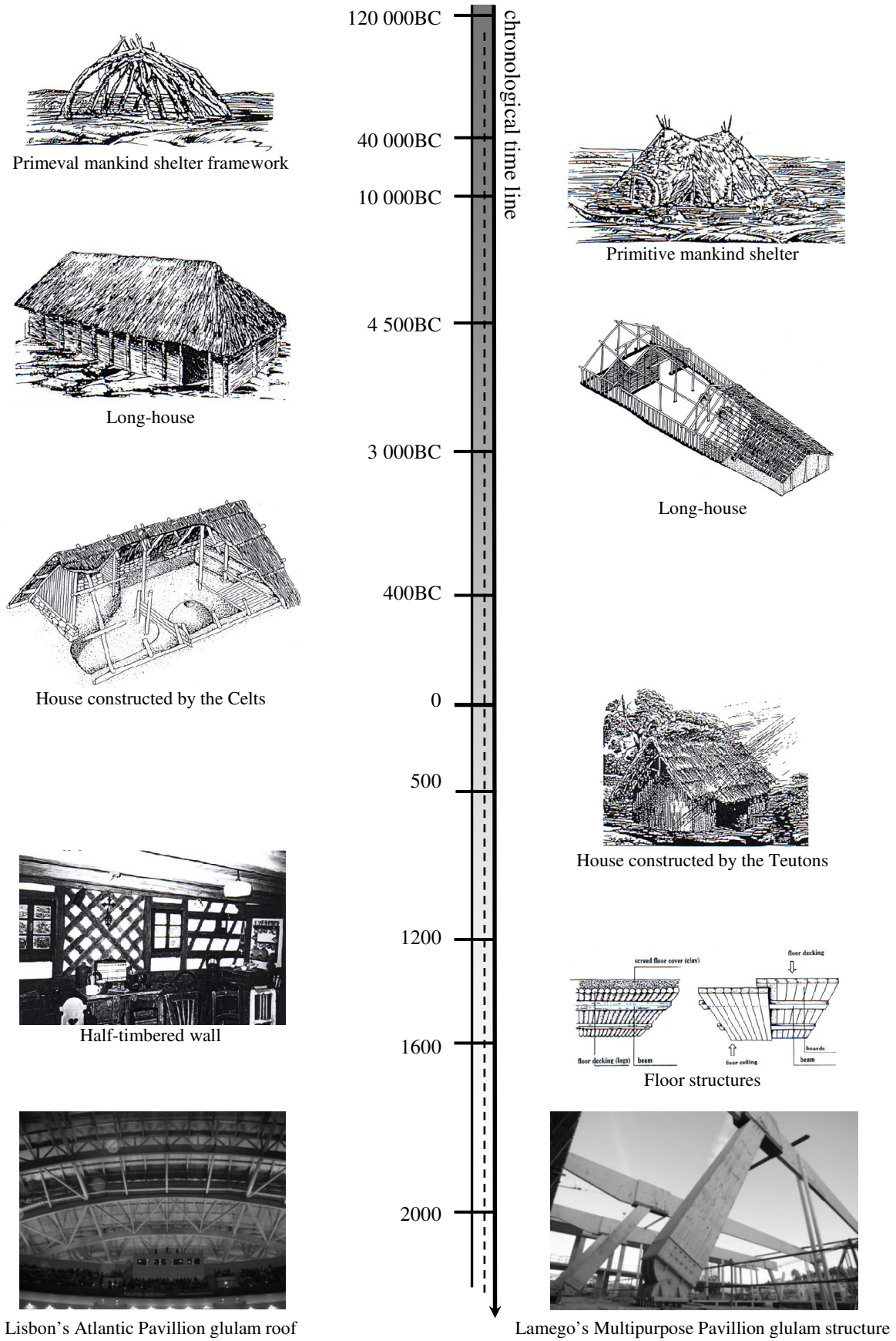

Figure 2.1: Chronological time line for different examples of timber structures in Europe.

## 2.3 TIMBER CHARACTERISTICS

Wood is an organic material composed by an agglomerate of tubular cells of different shapes and variable length. Generally, depending of its origin, wood may be classified in two different categories:

- Hardwoods harvested from broad-leave trees, included in the angiosperm trees and normally with a slow growing process for the cases of European tree species. In temperate and boreal latitudes the tree species are mainly deciduous, but in the tropics and subtropics also evergreen species are found. Common deciduous European hardwoods include oaks, beech, ash, maple, cherry and chestnut. Tropical hardwoods include teak, mahogany and ebony;
- Softwoods harvested from conifers, included in the gymnosperm trees and normally with a fast growing process for the cases of European tree species. Mostly of these trees are evergreen and have needle shaped leaves, exception is regarded for bald cypress and larches. Softwoods are the main source of world's production of timber and its use is diverse going from structural purposes, furniture to raw material as pulp in paper production. Common examples are pine and spruce.

Due to the different functions that a tree stem must fulfil along its lifetime regarding structural support (trees must essentially withstand their own height and wind actions), transport of sap, processing and storage of products and by-products of photosynthesis, its transverse section structure has distinct areas, as schematically seen in Figure 2.2.

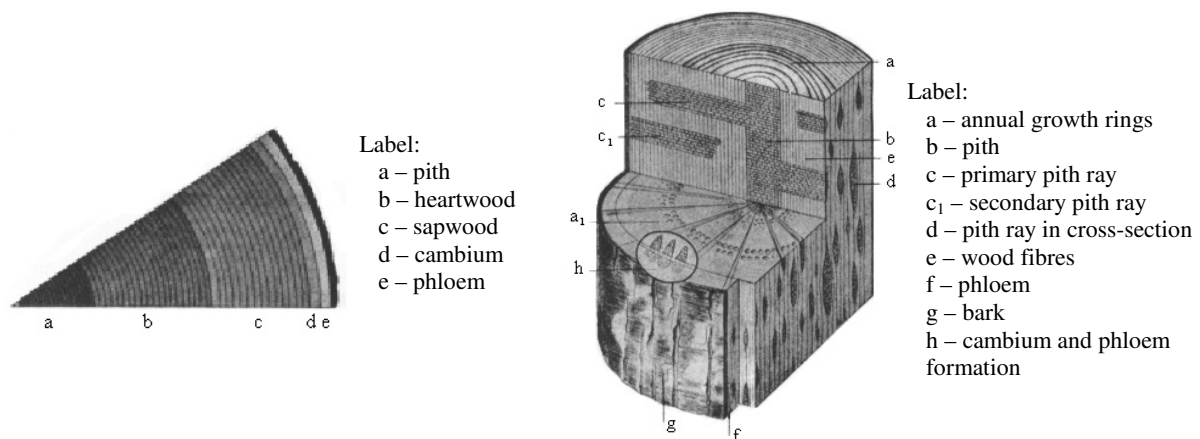

Figure 2.2: Schematic drawing of a stem cross-section of a softwood broad-leave tree specimen, adapted from Asso [1985]

The bark or outer protection of the tree is composed by two layers. A stratum of dead cells is found superficially and its thickness varies with the age and specie of the tree, while internally a thin layer made of living cells called phloem allows the transport of nutritive substances (sap) from the leaves to the stem. In the phloem, a process of cellular division called mitosis occurs and so new growth rings are formed concentrically in relation to the pith.

Sapwood is the designation of the external and lighter rings, with low mechanical resistance and susceptible to biological attack (fungi and xylophagous insects). It presents easily impregnable layers with high level of absorption. Its main function is the transport of sap from the roots to the leaves.

The heartwood is composed by dead cells, impregnated with several minerals, and presents a darker coloration. It also has higher density, higher mechanical resistance and better resistance to biological attack. Conifers' heartwood is impregnated with resin, while broadleaf trees' heartwood is impregnated with tannins.

The pith is the core of the tree stem where the first growing stage occurred.

The growth rings are formed by the phloem and may be classified in two distinct types: the annual rings and the seasonal rings (tropical regions). For each kind of growth ring there is a distinction between wood formed in Spring and wood formed in Summer time (also known as Autumn wood), as seen in Figure 2.3. The density of resinous wood decreases with larger rings [Rodrigues, 2004].

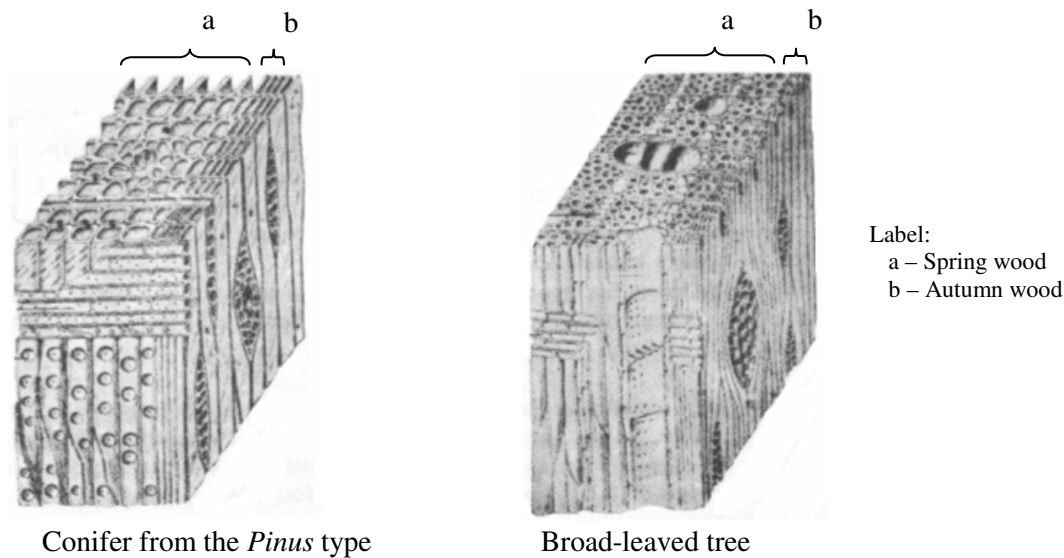

Figure 2.3: Schematic drawing of different wood structures adapted from Asso [1985]

Timber presents an anisotropic behaviour due to the orientation of its cells and constituents. Therefore, its mechanical behaviour also depends on the direction on which it is being loaded. Three different scenarios are often considered depending on the orientation of timber's fibres:

- Axial or longitudinal direction – parallel to grain;
- Tangential direction – perpendicular to grain and tangent to the growth rings;
- or Radial – perpendicular to grain and to the growth rings (Figure 2.4).

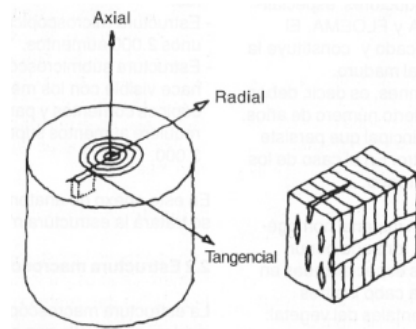

Figure 2.4: Principal directions in timber elements, adapted from Casasús et al [1997].

Timber shows a good resistant behaviour for tension and compression when loaded with direction parallel to grain. In tension the relation between stress and deformation is practically linear until failure. In compression the same relation normally offers a linear stage followed by a second non-linear stage. The resistance in compression for slender elements decreases when the modulus of elasticity also decreases.

While that, for elements clean of defects the resistance in tension may lead to higher values than in compression, for graded timber the situation is inverted due to the influence of defects in timber, mainly due to knots. This happens due to the misalignment of fibres that in tension leads to stresses perpendicular to the timber grain.

In the direction perpendicular to grain, timber presents a lower resistance to tension (approximately 30 to 70 less when compared to direction parallel to grain, which basically consists in null resistances), associated with the lack of sufficient fibres in the direction perpendicular to the axis of the tree that could ensure locking of the longitudinal fibres when exposed to this kind of loading. This may pose as a problem when designing curved elements, but is specially important for the design of traditional connections. Also the compression resistance of timber perpendicular to grain is inferior to the case of direction parallel to grain. In this case, the relation between stress and deformation is, at an early stage, linear and followed by crushing of fibres and by the failure of the element. This type of situation is usually found at beam supports, where the totality of loading is concentrated in small surfaces which should transmit the reaction without any deformation.

Timber resistance to simple bending is often high. However, the influence of large defects leads to lower values of bending resistance.

Regarding the modulus of elasticity its worthwhile mentioning that it varies according to the type of applied load (tension or compression) and direction. Normally, the modulus of elasticity corresponding to bending is used to characterize the timber element.

Timber's mechanical characteristics are influenced by the moisture content, load duration and also by the quality of the wood and production processes. In a smaller scale, variations of temperature and size effect also influence timber's mechanical characteristics.

The mechanical behaviour of timber may not be fully derived from the properties of clear wood, because timber presents a large spatial and random variability in strength and stiffness. The presence of knots, zones with reaction wood in timber of resinous trees, oblique fibre orientation, decay and other defects are extremely important to characterize the resistance parameters of timber and may well be different from element to element even in the same structure. Thus, structural properties of sawn timber exhibit a significant variability and therefore strength properties of structural timber are often determined by direct testing of timber elements according to standardised methodology, and strength is defined on the element rather than on the material level [Thelanderson and Honf, 2009].

## **2.4 TIMBER STOCHASTIC MODELS**

Regarding each basic random variable, uncertainty modelling must be considered for the calculus of the considered limit state function. Most engineering structures are affected by the following types of uncertainty [JCSS, 2000]:

- Intrinsic physical or mechanical uncertainty: when considered at a fundamental level, this uncertainty source is often best described by stochastic process in time and space, although it is often modelled more simply in engineering applications through random variables;
- Measurement uncertainty: this may arise from random and systematic errors in the measurement of these physical quantities;
- Statistical uncertainty: due to reliance on limited information and finite samples;
- Model uncertainty: related to the predictive accuracy of calculation models used.

The physical uncertainty in a basic random variable is represented by adopting a suitable probability distribution, and therefore adequate resistance models are necessary for the special case of timber structures due to the variability of properties found for this material.

The following indications may be considered helpful in selecting a suitable probabilistic model for material properties [JCSS, 2000]:

- Frequency of negative values is normally zero;
- Log-normal distribution can often be used;
- Weibull distribution may be used when large defects are important for strength characterization, see Table 2.1 for tension strength;

- Distribution type and parameters should, in general, be derived from large homogeneous samples and with due account of established distributions for similar variables; tests should be planned so that they are, as far as possible, a realistic description of the potential use of the material in real applications.

Also for geometric properties the following remarks may be considered helpful in selecting a suitable probabilistic model [JCSS, 2000]:

- Variability in structural dimensions and overall geometry tends to be small;
- Dimensional variables can be adequately modelled by normal or log-normal distributions;
- If the variable is physically bounded, a truncated distribution may be appropriate; such bounds should always be considered to avoid entering into physically inadmissible ranges;
- Variables linked to manufacturing can have large coefficients of variation.

### 2.4.1 Resistance models

Stochastic resistance models for timber as a construction material are specified in the Probabilistic Model Code – PMC – given by the Joint Committee on Structural Safety [JCSS, 2006]. The stochastic models that characterize the mechanical properties of timber are described in the PMC, where from the knowledge of some specific properties, considered explicitly, one may obtain the others implicitly. The explicitly considered properties are defined as reference properties or also so-called key properties. These properties are the bending strength  $f_m$ , bending modulus of elasticity  $E_m$  and density  $\rho_m$ .

Considering the PMC, the other resistance properties of timber can be defined based in the key properties through the empirical expressions, presented in Table 2.1, where also probabilistic distributions are given for the definition of each property.

Table 2.1: Relation between key properties (shaded) and other properties adapted from JCSS [2006]

Property, X	Distribution	Expected values, E[X]	Coef. of Variation, CoV[X]
Bending strength, $f_m$	Lognormal	E [ $f_m$ ]	0.25
Bending modulus of elasticity, $E_m$	Lognormal	E [ $E_m$ ]	0.13
Density, $\rho_m$	Normal	E [ $\rho_m$ ]	0.10
Tension strength parallel to the grain, $f_{t,0}$	Lognormal	0.6 E [ $f_m$ ]	1.2 CoV [ $f_m$ ]
Tension strength perpendicular to the grain, $f_{t,90}$	Weibull	0.015 E [ $\rho_m$ ]	2.5 CoV [ $\rho_m$ ]
MOE – tension parallel to the grain, $E_{t,0}$	Lognormal	E [ $E_m$ ]	CoV [ $E_m$ ]
MOE – tension perpendicular to the grain, $E_{t,90}$	Lognormal	E [ $E_m$ ]/30	CoV [ $E_m$ ]
Compression strength parallel to the grain, $f_{c,0}$	Lognormal	5 E [ $f_m$ ] <sup>0.45</sup>	0.8 CoV [ $f_m$ ]
Compression strength perpendicular to the grain, $f_{c,90}$	Normal	0.008 E [ $\rho_m$ ]	CoV [ $\rho_m$ ]
Shear modulus, $G_v$	Lognormal	E [ $E_m$ ]/16	CoV [ $E_m$ ]
Shear strength, $f_v$	Lognormal	0.2 E [ $f_m$ ] <sup>0.8</sup>	CoV [ $f_m$ ]

The indicative values for correlation between variables are shown in Table 2.2 in form of a matrix. As the matrix is symmetric only the values above the principal diagonal are presented.



Table 2.2: Correlation matrix coefficients adapted from JCSS [2006]

	$f_m$	$E_m$	$\rho_m$	$f_{t,0}$	$f_{t,90}$	$E_{t,0}$	$E_{t,90}$	$f_{c,0}$	$f_{c,90}$	$G_v$	$f_v$
$f_m$	1	0.8	0.6	0.8	0.4	0.6	0.6	0.8	0.6	0.4	0.4
$E_m$	:	1	0.6	0.6	0.4	0.8	0.4	0.6	0.4	0.6	0.4
$\rho_m$	:	:	1	0.4	0.4	0.6	0.6	0.8	0.8	0.6	0.6
$f_{t,0}$	:	:	:	1	0.2	0.8	0.2	0.5	0.4	0.4	0.6
$f_{t,90}$	:	:	:	:	1	0.4	0.4	0.2	0.4	0.4	0.6
$E_{t,0}$	:	:	:	:	:	1	0.4	0.4	0.4	0.6	0.4
$E_{t,90}$	:	:	:	:	:	:	1	0.6	0.2	0.6	0.6
$f_{c,0}$	:	:	:	:	:	:	:	1	0.6	0.4	0.4
$f_{c,90}$	:	:	:	:	:	:	:	:	1	0.4	0.4
$G_v$	:	:	:	:	:	:	:	:	:	1	0.6
$f_v$	:	:	:	:	:	:	:	:	:	:	1

In the previous table the different coefficients should be understood as:

- 0.8 is a high correlation;
- 0.6 is a medium correlation;
- 0.4 is a low correlation;
- 0.2 is a very low correlation.

Since reference material properties are sensitive to the deviations from the standard test conditions, different in situ properties of a cross-section are possible. Those properties may be estimated as [JCSS, 2006]:

$$f_m = \alpha(Ex(S, \omega, \tau, T)) f_{m,0} \quad (2.1)$$

$$E_m = E_{m,0} / (1 + \delta(Ex(S, \omega, \tau, T))) \quad (2.2)$$

$$\rho_m = \rho_{m,0} \quad (2.3)$$

where  $Ex(S, \omega, \tau, T)$  is the exposure of the structure to loads  $S$ , humidity  $\omega$  and temperature  $\tau$ , in the time interval  $[0, T]$ ;  $\alpha(Ex(.))$  is a strength modification function;  $\delta(Ex(.))$  is a stiffness modification function.

The parameters  $f_{m,0}$ ,  $E_{m,0}$  and  $\rho_{m,0}$  are the bending strength, the modulus of elasticity and the density of a cross-section under test conditions. Those properties are assumed to be equal to the properties of the corresponding standard test specimen, thus it is assumed that these properties are constant within the test specimen and within the structural components.

The strength and stiffness modification functions are in general for a particular set of discrete exposures, as given in Eurocode 5 [CEN, 2004]. Those set of exposures are differentiated in different service classes according to relative air humidity, temperature or equivalent moisture content. Values for  $\alpha(.)$  and  $\delta(.)$  are given in Tables 2.3 and 2.4, as taken from Eurocode 5 where they are called, respectively,  $k_{mod}$  and  $k_{def}$  coefficients. As mentioned above, the behaviour of timber depends on the duration of loads and the moisture content of timber. For design, in Eurocode 5 [CEN, 2004] the impact of these effects can be modelled through a deterministic parameter, usually denoted  $k_{mod}$ , which affects the resistance of the timber structure or elements.

Table 2.3: Strength modification function table for constant loads with different duration [JCSS, 2006].

Service class	Permanent ( $T > 10$ years)	Long term ( $0.5 < T < 10$ years)	Medium term ( $0.25 < T < 6$ months)	Short term ( $T < 1$ week)	Instantaneous
1 or 2	$\alpha = 0.60$	$\alpha = 0.70$	$\alpha = 0.80$	$\alpha = 0.90$	$\alpha = 1.10$
3	$\alpha = 0.50$	$\alpha = 0.55$	$\alpha = 0.65$	$\alpha = 0.70$	$\alpha = 0.90$

Table 2.4: Stiffness modification function table for constant loads with different duration [JCSS, 2006].

Service class	Permanent ( $T > 10$ years)	Long term ( $0.5 < T < 10$ years)	Medium term ( $0.25 < T < 6$ months)	Short term ( $T < 1$ week)	Instantaneous
1	$\delta = 0.60$	$\delta = 0.50$	$\delta = 0.25$	$\delta = 0.00$	$\delta = 0.00$
2	$\delta = 0.80$	$\delta = 0.50$	$\delta = 0.25$	$\delta = 0.00$	$\delta = 0.00$
3	$\delta = 2.00$	$\delta = 1.50$	$\delta = 0.75$	$\delta = 0.30$	$\delta = 0.00$

### 2.4.2 Spatial variability

As mentioned previously, timber properties present spatial variability, thus the value of strength in one point of an element may not be the equal when compared with another point of the same element. Following a model proposed by Isaksson [1999], the bending strength  $f_{m,ij}$  at a particular point  $j$  in the component  $i$  of a structure/batch has a lognormal distribution and is given as:

$$f_{m,ij} = \exp(\nu + \varpi_i + \chi_{ij}) \quad (2.4)$$

where  $\nu$  is the unknown logarithm of the mean strength of all sections in all components (see Figure 2.5),  $\varpi_i$  is normal distributed with mean value equal to zero and standard deviation  $\sigma_\varpi$  and represents the difference between the logarithm of the mean strength of the sections within a component  $i$  and  $\nu$ ;  $\chi_{ij}$  is normal distributed with mean value equal to zero and standard deviation  $\sigma_\chi$  and represents the difference between the strength weak section  $j$  in the beam  $i$  and the value  $\nu + \varpi_i$ ;  $\varpi_i$  and  $\chi_{ij}$  are statistically independent.

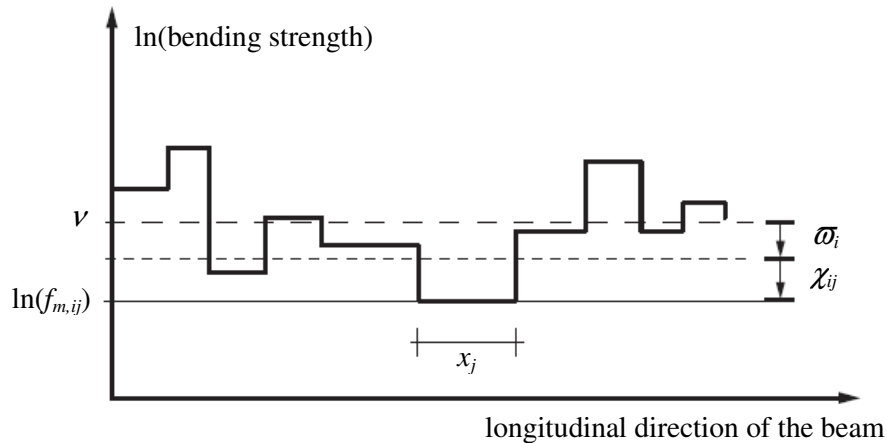

Figure 2.5: Section model for the longitudinal variation of bending strength [JCSS, 2006].

### 2.4.3 Size effect

The dimensions of a specific timber element affect the strength, since there is higher probability of having a weaker section for a element with higher length or also, in general, with any increase of

cross-section dimensions. When the strength parameter is described by a Weibull distribution, the probability of failure may be stated as:

$$P_f = 1 - e^{-\left(\frac{a-b}{a}\right)^{1/k}} \quad (2.5)$$

where  $a$  is the scale factor,  $b$  the location factor and  $k$  shape factor.

Generally it can be shown that the following relationship will apply between two volumes  $V$  if the location factor is set to zero:

$$\frac{\sigma_2}{\sigma_1} = \left(\frac{V_1}{V_2}\right)^k \quad (2.6)$$

where  $\sigma_1$  and  $\sigma_2$  are the stresses causing failures for volumes  $V_1$  and  $V_2$ , respectively.

In Eurocode 5 [CEN, 2004] a factor  $k_h$  is applied, when heights in bending or widths in tension of solid timber are less than 150 mm, to increase the characteristic values of  $f_{mk}$  and  $f_{t,0,k}$ . This value is given as:

$$k_h = \min \left\{ \begin{array}{l} \left(\frac{150}{h}\right)^{0.2} \\ 1.3 \end{array} \right. \quad (2.7)$$

where  $h$  is the depth for bending members or width for tension members, in mm.

Also in standard NP EN 1194 [1999] size factors are considered for destructive tests. Those factors are due to the probability of defects in a given element. In bending, if the element dimensions are inferior to the reference dimensions of width  $b$  and height  $h$  ( $b = 150$  mm;  $h = 600$  mm) then the test results must be multiplied by:

$$k_{size} = \left(\frac{b}{150}\right)^{0.05} \left(\frac{h}{600}\right)^{0.1} \quad (2.8)$$

In tension, if the element dimensions are inferior to the reference dimensions of height  $h$  and length  $l$  ( $h = 150$  mm;  $l = 2000$  mm) then the test results must be multiplied by:

$$k_{size} = \left(\frac{h}{150}\right)^{0.1} \left(\frac{l}{2000}\right)^{0.1} \quad (2.9)$$

#### 2.4.4 Failure types

The importance of knowing the strength properties of the material as well as the configuration of applied loads are determinant for design. In design circumstances, brittle failures are avoided and ductile failures are preferable. For structural timber different failure types are given in Table 2.5 regarding different failure modes.

Table 2.5: Failure types for different failure modes for structural timber [JCSS, 2006].

Property	Failure type
Bending, $f_m$	Ductile <sup>1)</sup>
Tension parallel to the grain, $f_{t,0}$	Brittle
Tension perpendicular to the grain, $f_{t,90}$	Brittle
Compression parallel to the grain, $f_{c,0}$	Ductile
Compression perpendicular to the grain, $f_{c,90}$	Ductile with reserve
Shear, $f_v$	Brittle

<sup>1)</sup> For lower grade timber the failure mode can be brittle

## 2.5 TIMBER PATHOLOGIES

Timber structures are affected by several exterior aggressors that originate different kind of pathologies, degradation and decay of the material. Usually pathological agents are differentiated in biotic and abiotic agents. The following table list several different agents and pathologies as well as related consequences.

Table 2.6: Timber's pathological agents and consequences adapted from Sousa [2009].

Agents		Pathologies/Consequences	
Abiotics	Water	cracks, shrinkage, blisters, deformation and distortions, warping and rotting wood	
	Sun	photo-degradation phenomenon	
	Fire	progressive destruction of the cross-section	
	mechanical, physical and chemical	cross-section degradation due to abrasion, impact and chemical attack	
Biotics	Flora	bacteria	decay / rotting and consequent destruction of the wood fibres' structure; residual cross-section reduction
		fungus	decay/rotting and consequent destruction of the wood fibres' structure; residual cross-section reduction
	Fauna	mammals	damage due to social and biological activity (creation of burrows and nests)
		birds	
		xylophagous insects	destruction of the internal structure of wood due to drilling and excavation of tunnels / galleries

The deterioration of timber structures, in particular in Southern Europe, is mostly consequence of attack of xylophagous insects and wood-destroying fungi. These attacks cause a destruction of timber in the outer areas of the section, progressing into the interior as can be seen in Figure 2.5.



Figure 2.5: Example of a decayed timber element: a) along its length and b) a decayed cross-section

Unlike the deterioration process in other materials, in some timber deterioration models the only effect taken into account is a change in geometry, as the mechanical properties are not affected. Therefore

the mean strength of a cross-section is given by the strength of the undecayed wood [Wang, et al 2008]. The deterioration of timber elements varies along the structure and, even if some sections present dramatic losses, others can be almost intact. However, a detailed modelling of spatial varying geometry is extremely complex and time consuming, above all due to the level of detail required during inspection of the structure [Sousa, et al 2010].

### 2.5.1 Deterioration and damage accumulation models

The deterioration phenomenon is a time-evolution process and it should be considered in design phase. When dealing with timber structures, decay due to xylophagous insects and fungi attack may lead to structural failures. Therefore, it is important to foresee the evolution of deterioration in order to promote better maintenance actions and longer durability of the structure. A detailed deterioration modelling may be complex and so simplified models are often proposed. These models must however attend to different aspects, of which should be highlighted:

- Timber specie;
- Resistance class;
- Pathological agent;
- Position of the element in the structure;
- Environmental and climacteric characteristics of the surrounding area.

As example of decay models it is mentioned a research conducted by Wang et al [2008] about timber poles inearthed in Australian soil and subjected to fungi attack, where first order probability theories were used. In this study, an idealized decay model with two parameters was used [Leicester, 2001]: an initial propagation period of the deterioration phenomenon,  $t_{lag}$  (year) and an annual penetration ratio,  $r$  (mm/year), see Figure 2.6.

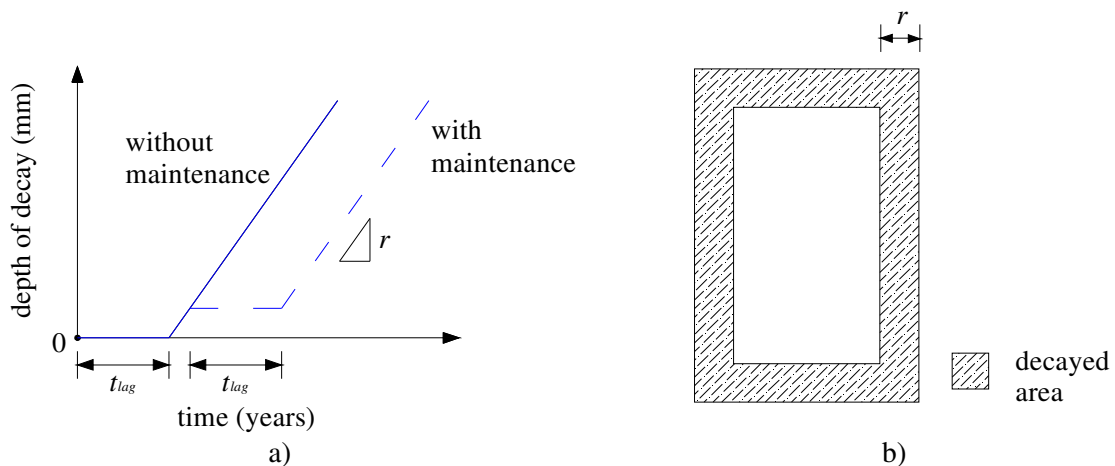

Figure 2.6: Progress of decay: a) idealized model, adapted from Leicester [2001]; b) damage penetration on a decayed cross-section.

In this model a constant annual penetration ratio is considered after the initial propagation period of deterioration. The penetration ratio per unit of time defines the evolution of deterioration and depends of two factors as stated:

$$r = k_{wood} \cdot k_{climate} \quad (2.10)$$

where  $k_{wood}$  depends upon the natural durability class of timber and  $k_{climate}$  depends on the climate conditions.

The value of  $t_{lag}$  may be obtained from value of  $r$ , as stated:

$$t_{lag} = 3 r^{-0.4} \quad (2.11)$$

In a stochastic analysis the parameter  $t_{lag}$  may be considered deterministically, while the parameter  $r$  may be defined through a lognormal distribution and COV in the interval of [0.5; 1.0], respectively for lower and higher timber durability classes [Brites et al, 2008].

Also other damage models are often used to describe the long term strength reduction as function of stress level and duration of loading. For example the following three models: Gerhard's model, Barret and Foschi's model and Foschi and Yao's model were used in the analysis of Nordic structural timber subjected to constant loading in Sørensen et al [2005].

The characteristics of the three damage models are that  $\alpha$  is defined as the degree of damage, such as  $\alpha = 0$  corresponds to a level of no damage and  $\alpha = 1$  corresponds to a total damage or failure.

Gerards' damage accumulation model [Gerards, 1979] is written:

$$\frac{d\alpha}{dt} = \exp\left(-A + B \frac{\sigma}{f_0}\right) \quad (2.12)$$

where  $A$  and  $B$  are constants,  $\sigma$  is the stress and  $f_0$  is the short term strength of the studied member. The solution for the differential, Eq. (2.12), may be stated as:

$$\frac{\sigma}{f_0} = \frac{A}{B} - \frac{\ln(10)}{B} \log(t) = a - b \log(t) \quad (2.13)$$

where:

$$a = \frac{A}{B} + \varepsilon \quad (2.14)$$

$$b = \frac{\ln(10)}{B} \quad (2.15)$$

and  $\varepsilon$  defines the model uncertainty related to this damage accumulation model. This parameter is assumed to have a normal distribution with expected value equal to 0 and standard deviation  $\sigma_\varepsilon$ . Then, assuming constant load, the residual strength  $f$  is given as:

$$\frac{f}{f_0} = \frac{1}{B} \ln(1 + (1 - \alpha)(\exp B - 1)) \quad (2.16)$$

Barrett and Foschi's damage accumulation model [Barrett and Foschi, 1978] is written:

$$\frac{d\alpha}{dt} = A \left(\frac{\sigma}{f_0} - \eta\right)^B + C \alpha \quad (2.17a)$$

$$\frac{\sigma}{f_0} > \eta \quad (2.17b)$$

$$\frac{d\alpha}{dt} = 0 \quad (2.17c)$$

$$\frac{\sigma}{f_0} \leq \eta \quad (2.17d)$$

where  $A$ ,  $B$  and  $C$  are constants,  $\eta$  is a threshold ratio,  $\sigma$  is the load in time and  $f_0$  is initial load carrying capacity of the studied member. A solution of Eq. (2.17) when  $\alpha = 1$  and for constant load is given by:

$$\frac{\sigma}{f_0} = \left( \frac{A}{C} (\exp(Ct) - 1) \right)^{-\frac{1}{B}} + \eta = a (\exp(\exp(b)t) - 1)^c + \eta \quad (2.18)$$

where:

$$a = \exp \left( \ln \left( \left( \frac{A}{B} \right)^{-\frac{1}{B}} \right) + \varepsilon \right) \quad (2.19)$$

$$b = \ln(C) \quad (2.20)$$

$$c = -\frac{1}{B} \quad (2.21)$$

and  $\varepsilon$  defines the model uncertainty related to this damage accumulation model. Then the residual strength  $f$  is given as:

$$\frac{f}{f_0} = \eta + [(1 - \alpha)(1 - \eta)^B]^{\frac{1}{B}} \quad (2.22)$$

The last model corresponded to Foschi and Yao's model [Foschi et al, 1987], which is presented as an extension of the previous model given in Eq. (2.17) and is stated as:

$$\frac{d\alpha}{dt} = A \left( \frac{\sigma}{f_0} - \eta \right)^B + C \left( \frac{\sigma}{f_0} - \eta \right)^D \alpha \quad (2.23a)$$

$$\frac{\sigma}{f_0} > \eta \quad (2.23b)$$

$$\frac{d\alpha}{dt} = 0 \quad (2.23c)$$

$$\frac{\sigma}{f_0} \leq \eta \quad (2.23d)$$

where  $A$ ,  $B$  and  $C$  are constants,  $\eta$  is a threshold ratio,  $\sigma$  is the stress and  $f_0$  is initial short term strength. A solution of Eq. (2.23) with short term ramp load ( $\sigma = kt$ ) until failure with initial strength  $f_0$  gives (considering a large rate of loading and a small  $C$ ) [Köhler and Svensson, 2002]:

$$A = \frac{k(B + 1)}{f_0(1 - \eta)^{(B+1)}} \quad (2.24)$$

and time failure  $t_f$ :

$$t_f = \ln \left( \frac{\sigma}{k} + \frac{1}{C \left( \frac{\sigma}{k} - \eta \right)^D} \ln \left( \frac{1 + \lambda}{\alpha_0 + \lambda} \right) \right) + \varepsilon \quad (2.25)$$

where:

$$\alpha_0 = \left( \frac{\frac{\sigma}{f_0} - \eta}{1 - \eta} \right)^{B+1} \quad (2.26)$$

$$\lambda = \frac{k(B+1)}{C f_0 (1 - \eta)^D} \left( \frac{\sigma}{f_0} - \eta \right)^{B-D} \quad (2.27)$$

and  $\varepsilon$  defines the model uncertainty related to this damage accumulation model. Then the residual strength  $f$  is given as:

$$\frac{f}{f_0} = \eta + (1 - \eta)(1 - \alpha)^{1/(1+B)} \quad (2.28)$$

As observed from the previous mentioned models, damage increases with time and therefore inspections techniques could be used to detect deterioration. Through a monitoring plan, it can also be possible to measure if that deterioration is active and its level of progression. Regarding the effects of degradation in timber structures tests are sometimes also necessary to assess its present state of conservation. In many circumstances, removing elements or the extraction of specimens is out of question due to historical, social or economic matters. Thus, non and minor-destructive tests – NDT and MDT – are often proposed.

Regarding different inspection and testing techniques different uncertainties related to these methods are expected. On topic 4.3 further information will be addressed regarding to the probability of detection and the probability of sizing for a given inspection technique.

## 2.5.2 Inspection techniques for timber structures

### *Visual inspection*

Visual inspection is one of the most important tasks to be carried out for structural diagnosis. The inspection should be carried out with the aim to study not only the causes, but also the future consequences of the problem [Ramos, 2010].

In a first phase, a careful visual inspection should give information about:

- description of the structure, in terms of geometry, history of construction and structural changes;
- indication of eventual auxiliary working platforms and safety measures for the inspection works;
- possibility of removal of some construction elements to provide a path for previously inaccessible parts of the structure;
- definition of the inspection equipment;
- identification of competence and responsibilities for the inspection works.

During the inspection works information is gathered to define the general state of the structure and, thus, different evidences of structural pathologies are noted and classified according to its extension and severity. In timber structures the most important aspects to be considered is the presence of defects in elements, moisture and / or water infiltrations and the presence of biological activity leading



to decay of elements. Also the presence of deformations and other structural irregularities are important.

Regarding timber structures, special attention must be drawn to the connections between elements and to its level of preservation. The safety conditions of a timber structure are highly dependant on the performance of the connections.

Despite the importance of visual inspections, sometimes it proves to be insufficient to obtain important information about the materials and about invisible aspects inside the structures. Thus, complementary diagnostic methods based on non or semi-destructive tests are necessary, for a full perspective of the problem.

### ***Resistograph***

The drill resistance measure by the Resistograph device is based on the resistance offered by the material to the advance of a small diameter drill bit and therefore depends on the density of the timber specimen, see Figure 2.6.



Figure 2.6: Resistograph use in a) top section b) middle section

The resistance offered by the timber element is registered in a real time device in a form of a graph. The analysis of this graph allows a qualitative measurement for the different parts of the cross-section and therefore making possible to assess and to differ hollow or decayed from solid or well preserved timber. Before conducting the drills in the decayed elements, solid timber elements from the same specie should be tested in order to obtain a reference value.

### ***Pilodyn***

The Pilodyn is an impact penetration technique that works by injecting a spring-loaded steel striker pin into the timber element, with a constant force. The depth of the penetration is, in principal, inversely proportional to the hardness of the timber element. A scale on the instrument gives the depth of penetration. However, although it is a fast, cheap and non-destructive method, it does not allow an exact determination of a timber element density. In one hand, as the striker pin only penetrates a small part of the superficial layer of the element it does not permit to assess the nucleus of the element. In the other hand, a higher or smaller penetration may also be derived from other factors rather than only from density, such factors may be the level of decay (timber quality), moisture contents and air temperature. Nevertheless, this test allows to define weak spots and also to give qualitative information about different cross-sections if an adequate mesh of inspected values is guaranteed. The use of this device is shown in Figure 2.7.



Figure 2.7: Pilodyn device and an example of its use

### 2.5.3 Hygrometer

The hygrometer measures the moisture content in the section of the element where it is applied. To use this device, first it is necessary to indicate the type of wood that will be studied and also the environmental temperature in order to calibrate the values. This device is based on the conductivity between the two metal pins that are inserted into the timber element. The values are then shown in a digital screen, see Figure 2.8.



a)



b)

Figure 2.8: Hygrometer: a) device instrument; b) in situ application

### 3. RELIABILITY OF STRUCTURES

#### 3.1 INTRODUCTION

In the past decades, an increasingly interest in reliability for civil engineering structural concepts is visible, mainly to higher computational performances and lower time costs that are now available. Also the possibility of implementing a certain degree of randomness and uncertainty to structural problems, when considering a stochastic analysis, is also an advantage.

The concept of structural reliability may be defined by the evaluation of the probability of a determined limit state function being violated. The basic reliability problem may essentially be assumed, in probabilistic terms, to be how a certain structure will perform its functions, on a specific period of time and according to defined conditions [Schneider, 1997]. Thus, it is possible to define a probability of failure,  $P_f$ , as the complementary probability to the definition of reliability, consequently obtaining a quantifiable parameter for the evaluation of a structure's safety.

In a structural reliability problem, the random variables that define and characterize the behaviour of the structure are called basic variables (e.g. cross-section dimensions, density, strength values, applied loads). When choosing the necessary basic variables in order to define a given problem, one must try to find independent variables, although that is not always possible. Modelling of these variables is possible through probabilistic distributions depending of the available information about them, and also their statistical parameters have to be chosen carefully. After obtaining a structural model, this must be confronted with existent information so it can be improved or revised. In the eventuality of insufficient information to describe the probabilistic function or to corroborate the proposed model, one might use a representative expected value so-called estimate point or of most likelihood.

The failure of a structural element is considered when the value of its resistance  $R$  is exceeded by the value of the load effect  $S$  resultant of a determined loading  $Q$ , on that specific element. Therefore,  $P_f$  may be assumed as the probability that the structural resistance  $R$ , modelled by a random variable with a known probability function  $f_R(r)$ , being inferior or equal to the load effects  $S$ , equally modelled by a random variable with a known probability function  $f_S(s)$ . According to this definition, the probability of failure may be expressed by one of the following ways [Melchers, 1999], which also shows that the limit state function can be formulated in different mathematical ways:

$$P_f = P(R \leq S) \quad (3.1a)$$

$$P(R - S \leq 0) \quad (3.1b)$$

$$P(R/S \leq 1) \quad (3.1c)$$

$$P(\ln R - \ln S \leq 1) \quad (3.1d)$$

$$P[g(R, S) \leq 0] \quad (3.1e)$$

where  $g( )$  defines the limit state function which probability of violation is identical to the probability of failure.

The safety margin  $M$  is consequently stated by:

$$M = R - S \quad (3.2)$$

When both  $R$  and  $S$  are given by normal random variables, with means  $\mu_R$  and  $\mu_S$  and variances  $\sigma_R^2$  and  $\sigma_S^2$ , respectively, the probability of failure according to Cornell [apud Melchers, 1999] may be stated as:

$$P_f = \Phi \left[ \frac{-(\mu_R - \mu_S)}{(\sigma_S^2 + \sigma_R^2)^{1/2}} \right] = \Phi(-\beta) = 1 - \Phi(\beta) \quad (3.3)$$

where  $\beta = \mu_M/\sigma_M$  is defined as reliability index and  $\Phi(\cdot)$  represents the standard normal distribution function. The relation between  $\beta$  and  $P_f$  is shown in Table 3.1.

Table 3.1: Relation between  $\beta$  and  $P_f$  according to Equation 3.3.

$P_f$	$10^{-1}$	$10^{-2}$	$10^{-3}$	$10^{-4}$	$10^{-5}$	$10^{-6}$	$10^{-7}$
$\beta$	1.28	2.32	3.09	3.72	4.27	4.75	5.20

When the stochastic variables are non-normally distributed or the failure function is not too non-linear, the probability of failure may be stated as:

$$p_f = P(g(X) \leq 0) \cong \Phi(-\beta) \quad (3.4)$$

The stochastic reliability methods due to their probabilistic nature, when applied to structural engineering problems, allow considering a large amount of information about the basic variables involved in the safety assessment of an existing structure.

Diverse target reliability indices are established for various structural situations by considering different consequences classes, reference periods of time and relative cost of safety measures. The *Eurocode 0* [CEN, 2002a] refers three reliability classes RC1, RC2 and RC3 associated with three consequences classes CC1, CC2 and CC3. The definition of the three reliability classes is given in Table 3.2, and the correspondent minimum target values for the reliability index  $\beta$  regarding ultimate limit states are stated in Table 3.3. RC is normally related directly to CC.

Table 3.2: Definition of consequences classes, adapted from CEN [2002a]

Consequences classes	Description	Examples of buildings and civil engineering works
CC1	<b>Low</b> consequence for loss of human life, <i>and</i> economic, social or environmental consequences <b>small or negligible</b>	Agricultural buildings where people do not normally enter, greenhouses
CC2	<b>Medium</b> consequence for loss of human life, economic, social or environmental consequences <b>considerable</b>	Residential and office buildings where consequences of failure are medium
CC3	<b>High</b> consequence for loss of human life, <i>or</i> economic, social or environmental consequences <b>very great</b>	Grandstands, public buildings where consequences of failure are high

Table 3.3: Recommended minimum values for reliability index  $\beta$  for ultimate limit states, adapted from CEN [2002a]

Reliability Class	Minimum values for $\beta$	
	1 year reference period	50 year reference period
RC1	4.2	3.3
RC2	4.7	3.8
RC3	5.2	4.3

The Probabilistic Model Code – PMC – [JCSS, 2000] recommends acceptable target reliability indices, for ultimate limit states, regarding a cost benefit analysis between relative cost of safety measures and consequences of a potential failure. Those values are given in Table 3.4 where the shadowed value should be considered as the most common design situation. The PMC also contains stochastic models for loads and strengths which will be better detailed in the following topics.

Table 3.4: Tentative target reliability indices  $\beta$  (and associated probabilities of failure) related to one year reference period of time and ultimate limit states, adapted from JCSS [2000]

Relative cost of safety measure	Consequences of failure		
	Minor	Moderate	Large
Large	$\beta = 3.1 (p_f \approx 10^{-3})$	$\beta = 3.3 (p_f \approx 5 \times 10^{-4})$	$\beta = 3.7 (p_f \approx 10^{-4})$
Normal	$\beta = 3.7 (p_f \approx 10^{-4})$	$\beta = 4.2 (p_f \approx 10^{-5})$	$\beta = 4.4 (p_f \approx 5 \times 10^{-6})$
Small	$\beta = 4.2 (p_f \approx 10^{-5})$	$\beta = 4.4 (p_f \approx 5 \times 10^{-6})$	$\beta = 4.7 (p_f \approx 10^{-6})$

Although the previous mentioned target reliability indices may be used for design and assessment of individual elements, their application is mainly addressed for global structures.

### 3.2 SYSTEM RELIABILITY ANALYSIS

The following topics address to system reliability analysis. Series and parallel systems are distinguished and also it is described how they may be evaluated in terms of reliability nature. Series of parallel systems are also mentioned.

#### 3.2.1 System concepts

In most engineering structures, collapse mechanisms are often related to the interaction between different elements of a global system, regarding stress redistribution and diverse material characteristics and properties. On one hand, the failure of a single element may lead to the global collapse of the structure whereas, on the other hand, a certain amount of element failing at the same time or sequentially may be needed to trigger a structural collapse. These events are often associated with redundancy, different load paths and material behaviour, but are not all totally described by them.

The concept of mechanical system is therefore derived as being a combination of individual elements organized and working as a sum of elements in order to perform a predetermined function [Park et al, 2004]. A failure element or component can be interpreted as a model of a specific failure mode, regarding a determined limit equation, at a specific location in the structure [Sørensen, 2004]. According to the required sequence of failing elements in order to obtain a global structural failure, two main distinct types of systems may be defined. Those systems are called series and parallel systems. A system is defined as a series system when the failure of any one of the single elements that compose the global structure leads also to the total collapse of the structure. In parallel systems it is necessary that more than a single element fails so that the global structural failure occurs. However, it is more suitable to assume that the failure of most structures may be due to the combinations of these two types of failure systems, therefore the definition of a hybrid system (both series and parallel systems combined) may be also encountered. Also, it is likely that a real redundant structure may have different element failure sequences that lead to a global failure. This type of system may be defined, as seen previously, as a hybrid system because it may be seen as a combination of series and parallel systems. However, the definition series of parallel systems might be more accurate when dealing with a multi possibility sequence of failure, from which the failure may be obtained from a series system composed by a subset of different individual parallel systems. Schematic drawings for different types of systems are shown in Figure 3.1.

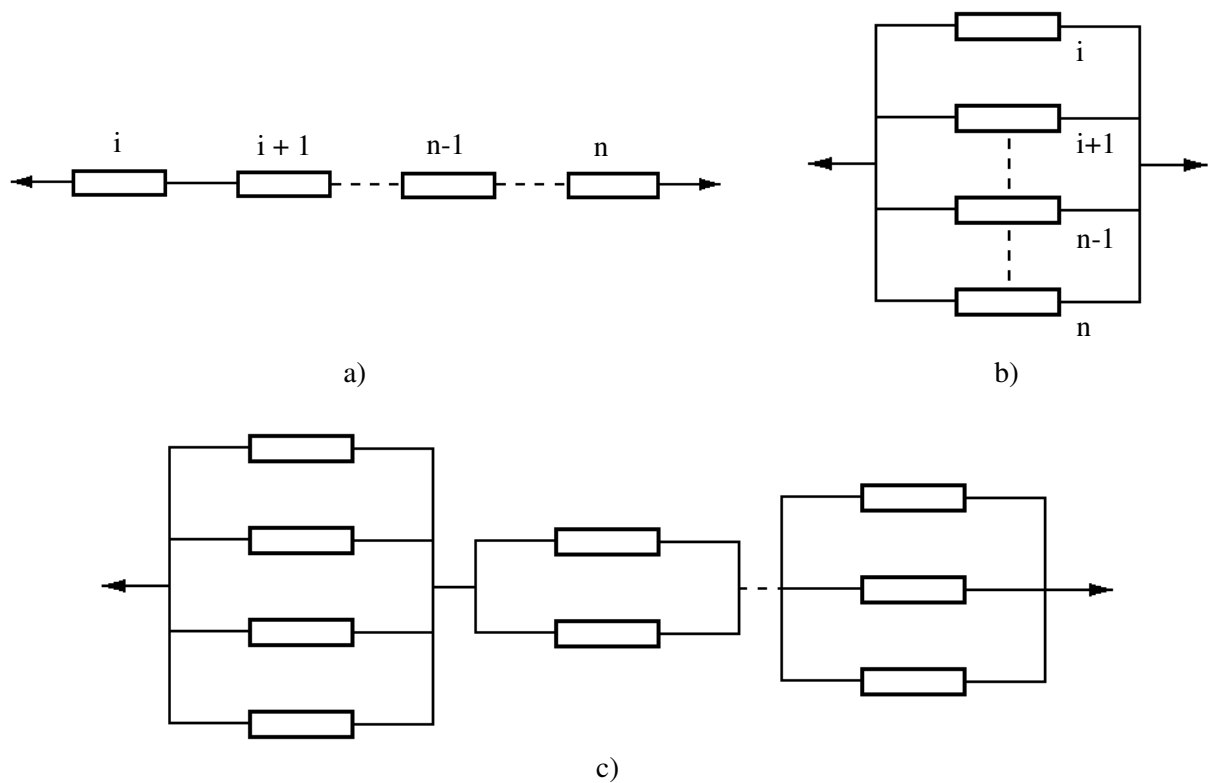

Figure 3.1: Different systems types: a) series; b) parallel; c) series of parallel systems.

From the above definitions, one may conclude that the importance of knowing which element might pose as the weakest link is crucial for the determination of failure of series systems, whereas for parallel systems the importance is mainly focused on the load sequence, stress redistribution and load bearing capacity after failure (ductile or brittle materials).

As previously mentioned, real structures might be defined as a combination of systems and so a more thorough study upon the different failure scenarios might reveal necessary. Taking as example the simple truss considered in Figure 3.2, different failures scenarios might be possible. Consider that the truss as been subjected to vertical descendent loads in the exterior hinges.

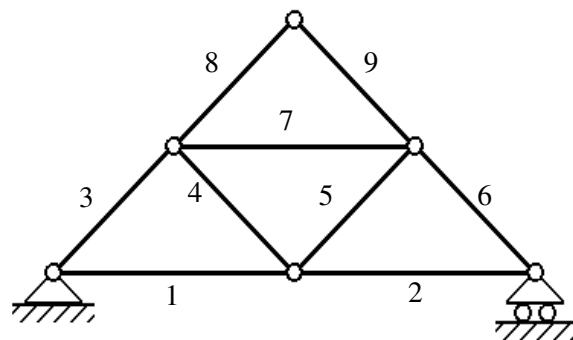

Figure 3.2: Isostatic truss structure.

Considering the failure of any of one of the elements (1,2,...,9), the structure becomes hypostatic (unstable frame), and so a local failure mechanism is obtained. However, only by considering the individual failure of elements 1 to 7 a global failure mechanism is obtained. For example, by removing either element 8 or 9, this might only lead to a partial failure of the truss' upper level. By individually removing elements 1 to 7 a local failure of the truss' lower level might be found, thus a global failure of the structure. The importance of elements 1 to 9 may take a designer to consider them as key

elements. However, the designer must not neglect the importance of stress redistribution when one of the other elements fails. Also, the serviceability aspects must be taken into account, for instance, if the truss is considered not functional when the upper level has failed, then elements 8 and 9 are also key elements. In terms of definition, this structure might be regarded as a simple series of parallel systems with the special detail that all parallel systems have as their final failure an element or a combination of elements from elements 1 to 7. Therefore, considering this structure as a simple series system may also be feasible if considering elements 1 to 7 as key elements. The schematic drawing of different failure sequences for this specific structure is shown in Figure 3.3.

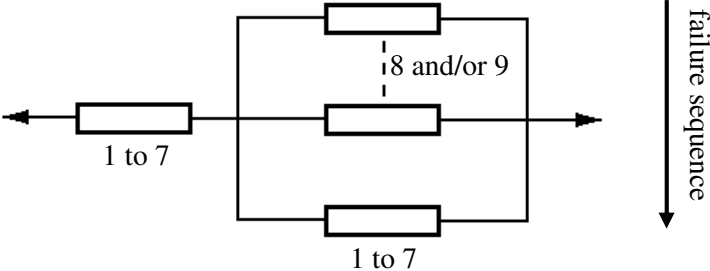

Figure 3.3: Different failure sequences for an isostatic truss structure.

In the perspective of the designer, a reasonable decision to take would be to create stronger elements for the key elements. However, in design of robust structures, very strong elements assuming a disproportionate role in the structural system should be avoided, and when that is not possible, adequate solution should be adopted to properly protect the most important members against any occurrence of damage [Biondini, 2008].

The analysis of a structural system may not be as prompt as seen for the example of the above isostatic truss structure. For instance, only by increasing a level to the same truss, as seen in Figure 3.4, many other failure sequences are obtained, due to new different load paths and different redistributions of load effects as well as regarding a higher degree of static indeterminacy. Consider, also, that the truss as been subjected to vertical descendent loads in the exterior hinges.

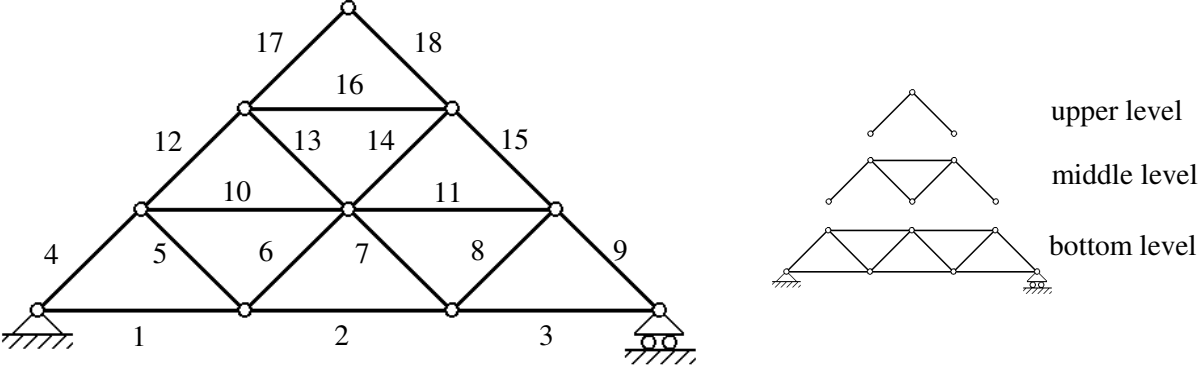
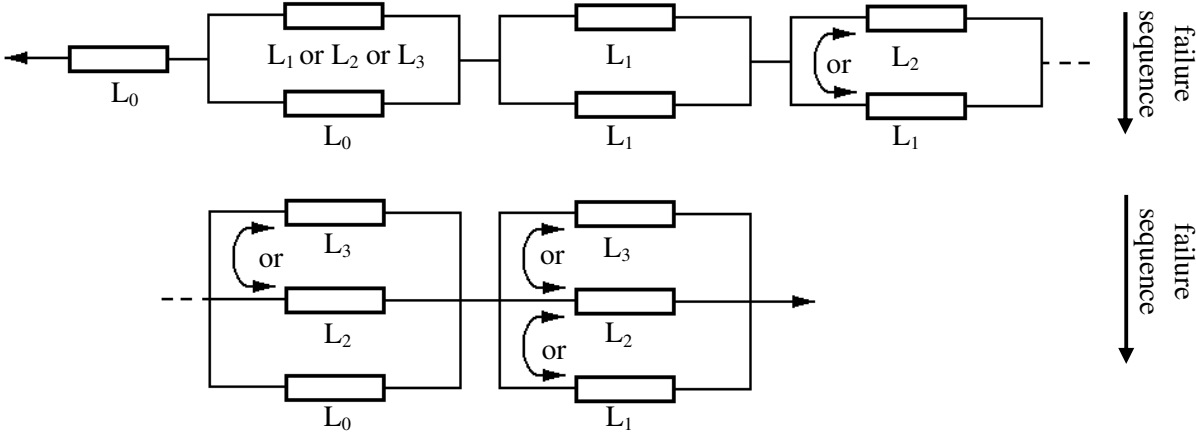

Figure 3.4: Three level truss structure: definition of elements and levels.

In this case, a failure of an element may not correspond to a failure mechanism, for instance even if elements from the bottom level corresponding to elements 2, 5, 6, 7, 8, 10 or 11 fail, the structure will not have a global failure. However, for the same level if elements 1, 3, 4 or 9 fail, then a global structural failure will be formed. Also, for a combination of any two failure elements among the bottom level will imply a failure of the structure. An equivalent situation is presented in the middle level, where an individual failure of elements 12, 13, 14, 15 or 16 does not imply a failure of the system. However, for the combination of two failure elements in level two will produce a partial

failure of the middle level and consequently of the upper level, although maintaining the bottom level if it has sufficient load bearing capacity. Combinations of two failure elements from the bottom and middle level will eventually also lead to a global collapse mechanism. At the upper level, a failure of either or both elements 17 and 18 will only result in the partial failure of that level. The schematic drawing of different failure sequences for this specific structure is shown in Figure 3.5.



$L_0$  = elements 1,3,4,9;  $L_1$  = elements 2, 5, 6, 7, 8, 10, 11;  $L_2$  = elements 12 to 16;  $L_3$  = elements 17, 18

Figure 3.5: Different failure sequences for a three level truss structure.

Although this system appears to be more complex than the previous isostatic truss, it is also simple to define the key elements of the structure, such as being the ones that ultimately will cause a global failure. Those elements are, thus, in decreasing order of importance: (i) elements 1, 3, 4 and 9; (ii) then the other elements from the bottom level; (iii) then the elements from the middle level; (iv) and finally the elements from the upper level. From this example, it is concluded that it is very important to exactly define which criteria were adopted for the failure of the structural system. For instance, if the collapse of one level would be considered as impeditive of the structure serviceability, then different failures mechanisms would be also taken, such as: (i) the combination of two failure elements from the middle level; (ii) the combination of two failures elements either from the lower or middle level with one from the upper level; (iii) and also the failure of one element in the upper level.

**3.2.2 Series systems**

Series systems are often related to statically determinate (non-redundant) structures, where the failure of an element leads to complete system failure. Normally, this type of configuration is called the weakest link system and modelled by a series system. In this case, the failure of one element is equal in definition to the structural failure of the system and, thus, the reliability of the series system is taken as the reliability of failure.

Taking into account a First Order Reliability Method – FORM – approximation for the reliability of series system, a structural system that is defined by a system reliability model of a series system of  $m$  failure elements, may describe the safety margin of each of the failure elements as:

$$M_i = g_i(X), i = 1, 2, \dots, m \tag{3.5}$$

where  $M$  is a stochastic variable called safety margin and  $g(X)$  is denoted as the failure function, both related to element  $i$ .



In many cases, stochastic variables are correlated and non-normally distributed and so to linearize the limit state equation, and to make it feasible to use in FORM applications, a transformation from correlated to uncorrelated stochastic variables is added to the procedure, regarding a correlation matrix  $\rho$ . The transformation between normal stochastic variables  $\mathbf{U}$  and the stochastic variables  $\mathbf{X}$  may symbolically written as  $\mathbf{X} = \mathbf{T}(\mathbf{U})$ , and the respective probability of failure for a single element  $i$  may be stated as:

$$P_{f_i} = P(M_i \leq 0) = P(g_i(X) \leq 0) = P(g_i(T(U)) \leq 0) \quad (3.6)$$

$$\approx P(\beta_i - \alpha_i^T U \leq 0) = \Phi(-\beta_i)$$

where  $\alpha$  represents a vector whose elements characterizes the importance of the stochastic variables. For independent stochastic variables,  $\alpha_i^2$  gives the percentage of the total uncertainty associated with  $U_i$ .

By definition, if one of the elements fails in a series system also a total collapse is observed, thus the probability of failure of a series system,  $P_f^S$ , is:

$$P_f^S = P\left(\bigcup_{i=1}^m \{M_i \leq 0\}\right) = P\left(\bigcup_{i=1}^m \{g_i(X) \leq 0\}\right) = P\left(\bigcup_{i=1}^m \{g_i(T(U)) \leq 0\}\right) \quad (3.7)$$

Therefore, by considering the failure functions linearized at their respective  $\beta$ -points as stated in Eq. (3.6), the following FORM approximation of the probability of failure of a series system is obtainable:

$$P_f^S \approx P\left(\bigcup_{i=1}^m \{\alpha_i^T U \leq -\beta_i\}\right) \quad (3.8)$$

which by considering complementary events, De Morgan's law allows Eq. (3.8) to be rewritten as:

$$P_f^S \approx 1 - P\left(\bigcap_{i=1}^m \{-\alpha_i^T U > -\beta_i\}\right) = 1 - P\left(\bigcap_{i=1}^m \{\alpha_i^T U < -\beta_i\}\right) = 1 - \Phi_m(\beta; \rho) \quad (3.9)$$

where  $\Phi_m$  is the  $m$ -dimensional normal distribution function, which for series system reliability purposes and when  $\beta_i$  and  $\rho_{ij}$  are both known, is defined as:

$$\Phi_m(\beta; \rho) = \int_{-\infty}^{\beta_1} \int_{-\infty}^{\beta_2} \dots \int_{-\infty}^{\beta_m} \varphi_m(\mathbf{x}; \rho) dx_1 dx_2 \dots dx_n \quad (3.10)$$

where  $\varphi_m$  is the  $m$ -dimensional normal density function:

$$\varphi_m(\mathbf{x}; \rho) = \frac{1}{(2\pi)^{m/2} |\rho|^{1/2}} \exp\left(-\frac{1}{2} \mathbf{x}^T \rho^{-1} \mathbf{x}\right) \quad (3.11)$$

The correlation coefficient  $\rho_{ij}$  between two linearized safety margins is:

$$\rho_{ij} = \alpha_i^T \alpha_j \quad (3.12)$$

From Eq. (3.9) a formal or so-called generalized series systems reliability index  $\beta^S$  can be introduced as:

$$P_f^S = 1 - \Phi_m(\beta; \rho) = \Phi(-\beta^S) \quad (3.13)$$

or:

$$\beta^S = -\Phi^{-1}(P_f^S) = -\Phi^{-1}(1 - \Phi_m(\beta; \rho)) \quad (3.14)$$

In respect to evaluate  $\Phi_m$  in Eq. (3.10) a time and processing costly numerical integration may be needed even for small dimensions. Therefore, different methods are proposed for hand calculation and even for computational calculations, such as bound methods and asymptotic approximate methods, respectively.

The simple bound method for reliability of series systems can be introduced as:

$$\max_{i=1}^m P(M_i \leq 0) \leq P_f^S \leq \sum_{i=1}^m (P(M_i \leq 0)) \quad (3.15)$$

where, for the case that all elements of the series system are fully correlated, the lower bound corresponds to the exact value for failure probability of the series system. In terms of reliability indices the previous equation can be rewritten as:

$$-\Phi^{-1}\left(\sum_{i=1}^m \Phi(-\beta_i)\right) \leq \beta^S \leq \min_{i=1}^m \beta_i \quad (3.16)$$

The simple bound method has special interest for practical use when a failure of one failure element is dominating in relation to the other failure elements, whereas it becomes too wide when there is no dominating failure of a failure element. For better results second-order bounds such as Ditlevsen bounds are often used. In that case the bounds are given by:

$$P_f^S \geq P(M_1 \leq 0) + \sum_{i=2}^m \max\left\{P(M_i \leq 0) - \sum_{j=1}^{i-1} P(M_i \leq 0) \cap M_j \leq 0), 0\right\} \quad (3.17a)$$

$$P_f^S \leq \sum_{i=1}^m P(M_i \leq 0) - \sum_{i=2}^m \max_{j < i} \{P(M_i \leq 0 \cap M_j \leq 0)\} \quad (3.17b)$$

In terms of reliability indices for the FORM approximation the previous equations can be rewritten as:

$$\Phi(-\beta^S) \geq \Phi(-\beta_1) + \sum_{i=2}^m \max\left\{\Phi(-\beta_i) - \sum_{j=1}^{i-1} \Phi_2(-\beta_i, -\beta_j; \rho_{ij}), 0\right\} \quad (3.18a)$$

$$\Phi(-\beta^S) \leq \sum_{i=1}^m \Phi(-\beta_i) - \sum_{i=2}^m \max_{j < i} \{\Phi_2(-\beta_i, -\beta_j; \rho_{ij})\} \quad (3.18b)$$

Since the numbering of the failure elements influences the bounds, it is often suggested that arranging the failure elements according to decreasing probability of failure might be considered a good option [Sørensen, 2004]. Although Ditlevsen bounds are frequently more accurate than the simple bounds, it requires the estimation of  $\Phi_2(-\beta_i, \beta_j; \rho_{ij})$  in Eq. (3.18).

In order to get an estimate of the sensitivity of a systems reliability index  $\beta^S$  with respect to a model parameter  $p$  it is usually sufficient to apply:

$$\frac{d\beta^S}{dp} \approx \frac{1}{\varphi(\beta^S)} \sum_{i=1}^m \frac{\partial \Phi_m(\beta; \rho)}{\partial \beta_i} \frac{d\beta_i}{dp} \quad (3.19)$$

where  $\partial \Phi_m(\beta, \rho) / \partial \beta_i$  can either be calculated numerically by finite differences or by semi-analytical methods.

### 3.2.3 Parallel systems

As mentioned previously in 3.2.1, parallel systems are found when more than one failure element is needed in order to have a global structural failure. An example of parallel systems may be found in some statically indeterminate structures (redundant) where the failure of an element does not lead to a global structural failure, but to load effect redistribution along the other load bearing elements. Nevertheless, if the existing load carrying capacity of the structure after load effect redistribution is not sufficient, then a progressive failure mechanism may take place, thus, leading to global collapse in ultimate state. Therefore, the behaviour of the structure after a failure element is of utmost importance, such being dependent of the structure typology, redundancy and material properties. From a material perspective, a certain element may either present no strength after failure or offer the same level of load-bearing capacity, being characterized as either being perfectly brittle or perfectly ductile, respectively. However, it is common sense that real materials neither assume a perfectly brittle or perfectly ductile behaviour but actually a combination in between and so behaving in different ways after failure. Taking into account these assumptions, it is clear that a reliability analysis of a parallel system is influenced by the structural behaviour of the considered failure mode, and therefore this must be clarified previously to any kind of analysis. This means that prior to any reliability analysis the behaviour of each element after a failure element (or after each step in the failure sequence) must be considered in terms of stress redistribution and remaining load-carrying capacity. Only after obtaining the failure functions for each failure sequence, it is possible to continue with a reliability evaluation of the parallel system without any more consideration of the system and structural behaviour.

Taking into account a FORM approximation for the reliability of parallel system, a structural system that is defined by a system reliability model of a parallel system of  $n$  failure elements, may describe the safety margin of each of the failure elements as:

$$M_i = g_i(X), i = 1, 2, \dots, n \quad (3.20)$$

where  $M$  is a stochastic variable called safety margin and  $g(X)$  is denoted as the failure function, both related to element  $i$ .

As previously mentioned, the transformation between normal stochastic variables  $\mathbf{U}$  and the stochastic variables  $\mathbf{X}$  may symbolically written as  $\mathbf{X} = \mathbf{T}(\mathbf{U})$ .

In a parallel system, the probability of failure  $P_f^P$  is described by the intersection of the individual failure events within a particular failure sequence, meaning that a parallel system fails when all of the elements of a failure sequence have failed. Thus, in probabilistic terms,  $P_f^P$  is stated as:

$$P_f^P = P\left(\bigcap_{i=1}^n \{M_i \leq 0\}\right) = P\left(\bigcap_{i=1}^n \{g_i(X) \leq 0\}\right) = P\left(\bigcap_{i=1}^n \{g_i(T(U)) \leq 0\}\right) \quad (3.21)$$

Then a  $\beta$ -point is considered as the point in the failure domain closest to the origin. The  $n_A$  out of the failure functions which equal zero at point  $u^*$  are then linearized at  $u^*$ , by:

$$M_i = \beta_i^J - \alpha_i^T U, \quad i = 1, 2, \dots, n_A \quad (3.22)$$

where:

$$\alpha_i = \frac{-\nabla_u g_i(T(u^*))}{|\nabla_u g_i(T(u^*))|} \quad (3.23)$$

and:

$$\beta_i^J = \alpha_i^T u^* \quad (3.24)$$

The FORM approximation of a parallel system then follows as:

$$P_f^P \approx P\left(\bigcap_{i=1}^{n_A} \{\beta_i^J - \alpha_i^T U \leq 0\}\right) = P\left(\bigcap_{i=1}^{n_A} \{-\alpha_i^T U \leq -\beta_i^J\}\right) = \Phi_{n_A}(-\beta^J; \rho) \quad (3.25)$$

where  $\Phi_{n_A}$  is the  $n_A$ -dimensional normal distribution function, and  $\rho_{ij}$  is as given in Eq. (3.12).

From Eq. (3.25) a formal or so-called generalized series systems reliability index  $\beta^P$  can be introduced as:

$$P_f^P = \Phi_{n_A}(-\beta^J; \rho) = \Phi(-\beta^P) \quad (3.26)$$

or:

$$\beta^P = -\Phi^{-1}(P_f^P) = -\Phi^{-1}\left(\Phi_{n_A}(-\beta^J; \rho)\right) \quad (3.27)$$

As seen for series systems, the calculation procedure for  $\Phi_{n_A}$  may generally not be performed by numerical integration within reasonable computational processing time. Therefore, bounds or approximate methods are used as well.

The simple bounds method for reliability of parallel systems can be introduced as:

$$0 \leq P_f^P \leq \min_{i=1}^{n_A} (P(M_i^J \leq 0)) \quad (3.28)$$

where  $M_i^J$ ,  $i = 1, \dots, n_A$ , are the linearized safety margins at the joint  $\beta$ -point. The upper bound corresponds to the exact value of  $P_f^P$  if all the  $n_A$  elements are fully correlated with  $\rho_{ij} = 1$ .

In the terms of reliability indices  $\beta^J$  is written as:

$$\max_{i=1}^{n_A} \beta_i^J \leq \beta^P \leq \infty \quad (3.29)$$

If all correlation coefficients  $\rho_{ij}$  between the  $n_A$  elements are higher than zero, the following simple bounds are obtained:

$$\prod_{i=1}^{n_A} P(M_i^J \leq 0) \leq P_f^P \leq \min_{i=1}^{n_A} (P(M_i^J \leq 0)) \quad (3.30)$$

where the lower bound corresponds to uncorrelated elements ( $\rho_{ij} = 0$ ,  $i \neq j$ ). In terms of  $\beta^J$  the previous equation can be reformulated as:

$$\max_{i=1}^{n_A} \beta_i^J \leq \beta^P \leq -\Phi^{-1} \left( \prod_{i=1}^{n_A} \Phi(-\beta_i^J) \right) \quad (3.31)$$

Similar to the application in series systems, the simple bounds method for parallel systems often provides wide results and therefore is only usable in some cases. Normally, a second-order bound method for  $P_f^P$  achieves better results. The second-order upper bound of  $P_f^P$  may be stated as:

$$P_f^P \leq \min_{i,j=1}^{n_A} P(M_i^J \leq 0 \cap M_j^J \leq 0) \quad (3.32)$$

and the corresponding lower bound of  $\beta^P$  is:

$$\beta^P \geq -\Phi^{-1} \left( \max_{i,j=1}^{n_A} \Phi_2(-\beta_i^J, -\beta_j^J, \rho_{ij}) \right) \quad (3.33)$$

The probabilities of failure of a parallel system of two elements  $\Phi_2 = (-\beta_i^J, -\beta_j^J, \rho_{ij})$  are as the probabilities used in Ditlevsen bounds for series systems.

For both series and parallel systems, other more refined and complex bounds can also be used, however in the context of this work those will not be addressed, for further knowledge the references Thoft-Christensen and Murotsu [1986], Hohenbichler [1984] and Gollwitzer and Rackwitz [1986] are suggested.

### 3.2.4 Series of parallel systems

As mentioned before, the majority of real life structures is not characterized by a simple series or parallel system, but is actually a combination of both. For instance, a redundant structure may have different failure sequences, as also shown before in the example of the three level truss. In a series of parallel systems the failure sequences may be modelled as individual sets of parallel systems, where if one of these systems fails then a global system failure also occurs.

In probabilistic terms, the probability of failure of series systems of  $n_P$  parallel systems each with  $m_i$ ,  $i = 1, 2, \dots, n_P$  failure elements may be written as a union of intersections, such as:

$$P_f^S = P \left( \bigcup_{i=1}^{n_P} \bigcap_{j=1}^{m_i} \{g_{ij}(X) \leq 0\} \right) \quad (3.34)$$

where  $g_{ij}$  is the failure function of element  $j$  in parallel system  $i$ .

The FORM approximation of the generalized system reliability index  $\beta^S$  is obtained as for a series system in Eq. (2.14):

$$\beta^S = -\Phi^{-1}(1 - \Phi_{n_P}(\beta^P; \rho^P)) \quad (3.35)$$

where  $\beta^p$  is an  $n_p$  -vector of generalized reliability indices for the individual subsets of parallel systems as calculated in Eq. (3.27) and  $\rho^p$  is a matrix of the corresponding approximate correlation coefficients between the parallel systems.

Although assuming that a series of parallel systems may better model real life structures in a reliability theoretical perspective, some remarks must be taken when a structural engineering perspective is taken. Firstly, the load bearing capacity of failure elements and, secondly, how the load is redistributed after each step in the failure sequence are aspects on which the reliability of a parallel systems depends. Thus, the systems reliability is dependent of the structural response and so it should be refined more than the structural model actually implies.

### 3.2.5 Ductile / Brittle materials influence in systems reliability

As previously mentioned, there are no perfectly ductile or perfectly brittle materials in real life, but a combination between those two limits. In Figure 3.6, perfectly ductile and perfectly brittle behaviour for elements after failure elements are shown. Although the consideration of an element's behaviour after failure is not important for reliability assessment of a series system, it is a significant factor for parallel systems. This means that for a parallel system it is necessary to analyse the behaviour of each element after a failure element (or after each step in the failure sequence) in terms of stress redistribution and remaining load-carrying capacity prior to any reliability assessment.

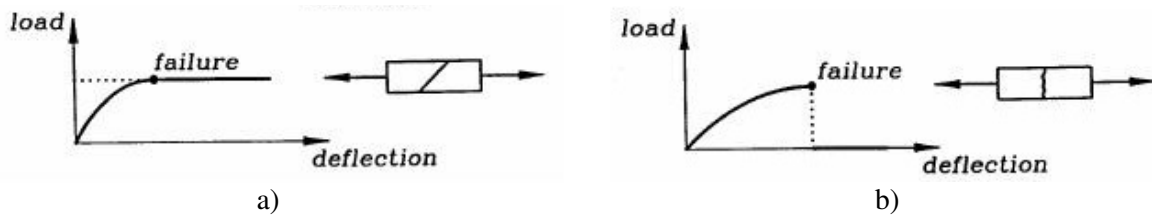

Figure 3.6: Material behaviour after failure: a) perfectly ductile; b) perfectly brittle

With a perfectly ductile material behaviour, if a element fails it will still contribute with load bearing capacity, whereas, with perfectly brittle behaviour that failure element will cease to contribute to the load bearing capacity of the structure. Therefore, in a perfect brittle material behaviour a failure element may be taken out from the analysis, such as it does not contribute any further for the resistance and strength of the structure. In a series system that would be considered to be the last step of a failure sequence and, thus, no further analysis has to be conducted. In a parallel system the stress redistribution to other elements must be considered. More information for assessment of parallel systems regarding material behaviour is therefore given as follows.

Given a certain parallel system of  $m$  independently distributed element strengths  $X_i$  with constant modulus of elasticity and perfect equal load sharing among ideally brittle elements [Gollwitzer and Rackwitz, 1990], submitted to a static load  $S$ . The system strength  $R_m$ , if the element strength is set in decreasing order, can be given by:

$$R_m = \max_{i=1}^n \{(m - i + 1) X_i\} \quad (3.36)$$

The corresponding system probability of failure is:

$$p_f = P(R_m \leq S) = P\left(\bigcap_{i=1}^m ((m - i + 1) X_i - S \leq 0)\right) \leq \min_{i=1}^n P((m - i + 1) X_i - S \leq 0) \quad (3.37)$$

The element failure event for a given imposed deformation  $\delta$ , in an arbitrary force-deformation curve, is:

$$F(\delta) = \sum_{i=1}^m R_i(\delta) - S \leq 0 \quad (3.38)$$

where  $S$  is the uncertain load and  $R$  denotes the uncertain element (component) force at deformation  $\delta$ . As consequence, system failure occurs if the maximum system resistance is exceeded by the load:

$$F_{sys} = \max_{\delta} \left( \sum_{i=1}^m R_i(\delta) - S \leq 0 \right) = \bigcap_{\delta} \left( \sum_{i=1}^m R_i(\delta) - S \leq 0 \right) \quad (3.39)$$

In Del Seno *et al* [2004] a numerical investigation was performed concerning the interaction of both parallel/series systems with ideal ductile/brittle material behaviour. The elements of the system were first designed in order to have a reliability index of  $\beta_{sys} = 2$ , as if no system effect existed. Then the number of elements  $n$  was increased and conclusions about the system reliability index were taken. Figure 3.7 pretends to demonstrate the influence of the mechanical behaviour of the elements' material in the system reliability. The first conclusion is that the reliability index largely increases for ductile and parallel systems with the increase of members. Even for medium brittle and brittle behaviour there is an increase of the reliability index, however much smaller. For ideal series system the reliability index decreases with the increase of elements, such as the probability of failure becomes higher. Also is seen that for a small number of elements the brittle system has a similar behaviour to the series system.

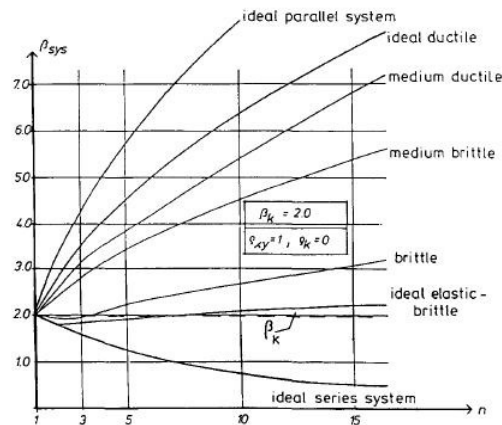

Figure 3.7: System reliability dependant of material behaviour and number of elements [Del Seno *et al* 2004]

### ***Ductility/brittleness of components***

In Figure 3.8, a five element system is addressed with respect to the influence of ductility. As ductility increases linearly the reliability of the system increases much steeper. Therefore, a relatively small increment in ductility accounts for a considerable increase in reliability. This conclusion is of special interest for designers that deal with the choice of materials, such as a more ductile material may increase the reliability of the structural system, however they are often more expensive.

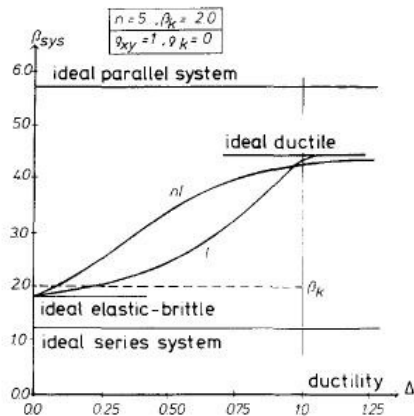

Figure 3.8: System reliability relation with ductility [Del Seno *et al* 2004]

### Stochastic dependencies

Figure 3.9 represents system reliability related with the influence of considering a certain correlation between element strength. It is easily noticed that reliability is largest for ideal ductility and zero correlation. The reliability decreases when correlation increases. For the medium correlation between element strength brittle systems presents a decrease in reliability.

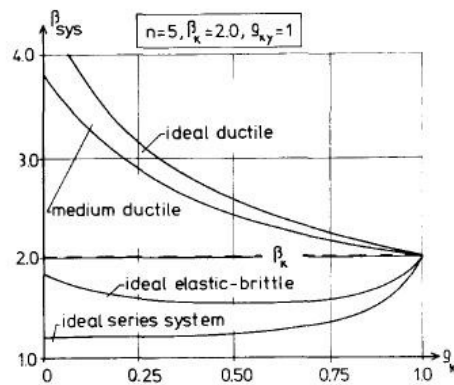

Figure 3.9: System reliability relation with correlation of strength between elements [Del Seno *et al* 2004]

### Load and strength variability

The reliability of the system was calculated for the case of load and strength variability ratio ranging from 0 to 5 (see figure 3.10a). Reliability is more influenced in the range of 0 to 2, where it presents a drastic decrement for ideal ductile behaviour. However, for brittle systems this decrement is not as pronounced as for ideal ductile systems.

Figure 3.10b presents a variation of only the element strength and the results show that the increase of strength leads, as could be expected, to an increment of the reliability index. Both brittle and ductile systems present a similar behaviour.



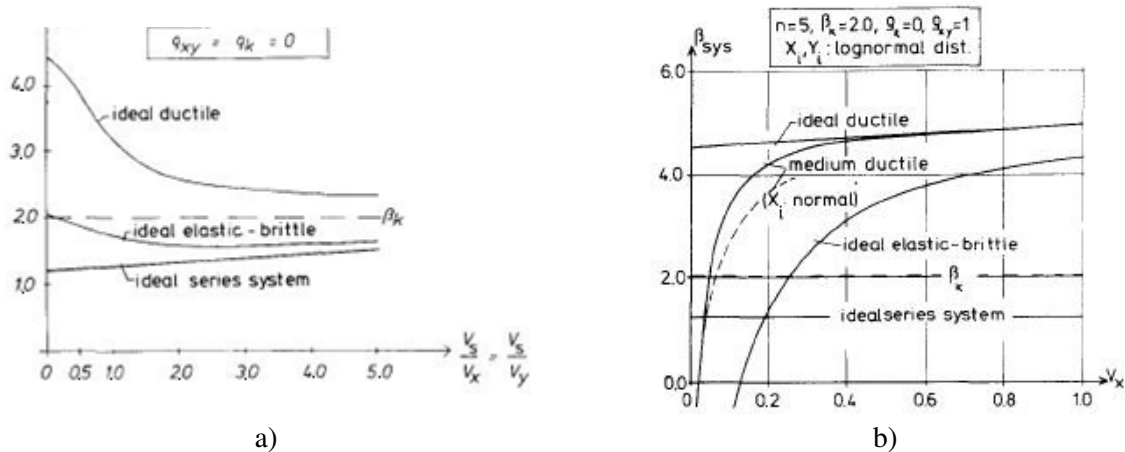

Figure 3.10: System reliability relation with variability of: a) ratio load/strength; b) element strength [Del Seno *et al* 2004]

To conclude, ductile systems will provide higher reliability for elements with low correlation or with no correlation, and when the load variability is not high, whereas, for a brittle material behaviour, there is a relatively little effect of the system. There may even present a small negative effect for medium coefficients of strength variation.

### 3.3 STOCHASTIC MODELS FOR LOADS

The reliability analysis of timber structures, such as other structures, requires three main steps:

- Definition of resistance properties;
- Definition of effects of actions and;
- Computation of the probability of failure or reliability index according to a given set of failure functions.

The stochastic resistance models for timber have already been addressed in section 2. This topic will address to load models. For computation of the probability of failure, topic 3.1 has already addressed the introductory concepts and further detailing shall be given in the following subtopics. Also it is important to determine the limit state equations when calculating the probability of failure and so also typical ultimate and serviceability limit state equations formulation is mentioned.

Depending on the surrounding environmental conditions, structural systems face internal forces, deformations, material deterioration and other short-term or long-effects. The causes of these effects are called actions. Actions may both derive from natural or human causes. In the PMC – part 2 [JCSS, 2001a], an action consisting of an assembly of concentrated or distributed forces acting on a structure may be denoted by load. The same document also, distinguishes actions according to time, as:

- Permanent actions: variations in time around their mean is small and slow or which monotonically presents a limiting value;
- Variable actions: variations in time are frequent and large;
- Accidental actions: magnitude can be considerable but whose probability of occurrence for a given structure is small related to the anticipated time of use. Frequently the duration is short.

The following indications may be considered helpful in selecting a suitable probabilistic model for load models [JCSS, 2001]:

- Loads should be divided according to their time variation (permanent, variable, accidental);
- In certain cases, permanent loads consist of the sum of many individual elements; they may be represented by a normal distribution;

- For single variable loads, the form of the point-in-time distribution is seldom of immediate relevance; often the important random variable is the magnitude of the largest extreme load that occurs during a specified reference period for which the probability of failure is calculated;
- The probability distribution of the largest extreme could be approximated by one of the asymptotic extreme distributions (Gumbel, and sometimes Frechet);
- When more than one variable load act in combination, load modelling is often undertaken using simplified rules suitable for FORM / SORM analysis.

Regarding the type of loads that normally are imposed to timber structures throughout their lifetime and taking into account those that precede regular inspections, a set of models for loads are given in the next subtopics. The knowledge of the loading history that a structure has been exposed to may be a useful tool for updating models, because the uncertainty of some parameters may be better assessed.

### 3.3.1 Permanent and imposed loads

Selfweight is obviously the prime example of permanent loads and for some structures may present an important part of the total loads. As previously mentioned, permanent loads and therefore the load due to the selfweight of structure, are usually assumed to be represented by a normal distribution. Indicative values for the weight density of different timber species are given in Table 3.5, for a moisture content of 12%.

Table 3.5: Mean value and coefficient of variation of timber weight densities [JCSS, 2001a]

Timber specie	Mean value [kN/m <sup>3</sup> ]	COV
Spruce, fir ( <i>Picea</i> )	4.4	0.10
Pine ( <i>Pinus</i> )	5.1	0.10
Larch ( <i>Larix</i> )	6.6	0.10
Beech ( <i>Fagus</i> )	6.8	0.10
Oak ( <i>Quercus</i> )	6.5	0.10

For volume estimation, it is often considered the nominal dimensions of the design cross-section. Normal distributions are often used for definition of the geometry. Mean values and standard deviations  $\sigma$ , for deviations of cross-section dimensions from their nominal values  $a_{nom}$ , are presented in Table 3.6 for the case of structural timber.

Table 3.6: Deviations of cross-section dimensions [JCSS, 2001a]

Structural members	Mean value	$\sigma$
Sawn beam or strut	0.05 $a_{nom}$	2 mm
Laminated beam, planed	$\approx 0$	1 mm

In Eurocode 1 part 1 [CEN, 2002b] a semi-probabilistic approach based in partial safety factors is proposed and different values for permanent loads and imposed loads are given according to different categories of use. Also in annex A of that document, nominal values of density for different classes of solid timber, glued laminated timber and other wood based materials are presented.

In Ranta-Maunus [2004], a normal distribution with COV = 0.05 or 0.1 is proposed for distributions and probabilistic properties of permanent loads.

### 3.3.2 Live loads

Live loads are caused by the weight of objects or people, mainly considered applied on the floors in buildings for a specific time interval. Not included in this type of load are any structural or non-

structural elements, partition walls or extraordinary equipment. Live loads values depend on the category of use for each specific building. Live loads vary both in time and space in a random manner. Regarding time variation, two components are distinguished as sustainable and intermittent loads.

The load intensity is represented by a stochastic field  $W(x,y)$ , where the parameters depend on the category use of the building, and is stated by JCSS [2001a]:

$$W(x,y) = m + V + U(x,y) \quad (3.36)$$

where  $m$  is the overall mean load intensity for a particular user category,  $V$  is a zero mean normal distributed variable and  $U(x,y)$  is a zero mean random field with characteristic skewness to the right. The quantities  $V$  and  $U$  are assumed to be stochastically independent.

Also a Gumbel distribution with  $COV = 0.2$  is proposed in Ranta-Maunus [2004] for variable floor loads.

### 3.3.3 Snow load

For snow loads on roofs  $S_r$ , the PMC [JCSS, 2001a] considers that its intensity is proportional to information given by meteorological data if all other parameters are constant, and thus it provides the following relation:

$$S_r = S_g r k^{h/h_r} \quad (3.37)$$

where  $S_g$  is the snow load on ground at the weather station,  $r$  is a conversion factor of snow load on ground to snow load on roofs,  $k$  is a region dependant coefficient and  $h/h_r$  is a coefficient regarding the altitude of the building site and a reference altitude.

For  $S_g$  a probabilistic model is proposed by a probability distribution function for the total duration of the load and a probability distribution function for the maximum load within one year. The distribution functions are then dependant of the building region, maritime or continental climate, and are in both cases defined by gamma distributions. The parameters should be based on local observations. As *prior* distribution a vague *prior* information should be considered. In some cases data from “similar stations” can be used as *prior* data with  $n' = 3$  and  $\nu' = 2$ . Later in this work, more information about *prior* information will be dealt.

Alternatively, using the annual maximum values it is possible to define characteristic values of snow load with respect to a certain exceedance, directly associated to a certain mean recurrence interval. The characteristic value for snow load, in Eurocodes and National annexes, is the value corresponding to a probability of only 2% of being exceeded within any one year. This value is corresponded to a mean recurrence time of 50 years. Based on this, snow load  $Q_{gk}$  on roof may be determined as:

$$Q_{gk} = S_g C \quad (3.38)$$

where  $S_g$  refers to snow on ground and  $C$  is the roof snow load shape factor. It is assumed that snow on ground has a Gumbel distribution and the shape factor  $C$  is also defined by a Gumbel distribution with expected value  $\mu_C = 1$  and standard deviation  $\sigma_C = 0.35$  [Sørensen et al, 2005].

In Ranta-Maunus [2004], a Gumbel distribution with  $COV = 0.4$  is proposed for snow loads where no *prior* regional information is available.

### 3.3.4 Wind load

The annual maximum wind load on a structure can be determined from:

$$Q_w = C P_{w,max} \quad (3.39)$$

where  $P_{w,max}$  is the annual maximum wind pressure (Gumbel distributed with COV=0.25) and  $C$  is a shape factor (modelled as Gumbel distributed with expected value  $\mu_C = 1$  and standard deviation  $\sigma_C = 0.215$ ) [Sørensen et al, 2005].

The wind load can also be modelled as a static uniformly distributed load. The intensity of this load depends on location and on geometry of the structure, where the mean value of the wind load can be defined based on the nominal values defined in Eurocode 1 part 4 [CEN, 2005].

In Ranta-Maunus [2004], a Gumbel distribution with COV = 0.4 is proposed for wind loads where no *prior* regional information is available.

### 3.3.5 Limit state equations

Typical ultimate limit state equation should be formed according to Köhler et al [2007]. The ultimate limit state equation for a cross section subjected to combined bending and tension parallel to grain is given as:

$$g_i(X) = 1 - \left( \frac{\sum_i S_{t,i}}{z_{d,A} R_{t,0}} + \frac{\sum_i S_{m,i}}{z_{d,M} R_m} \right) X_M = 0 \quad (3.40)$$

where  $z_{d,A}$  and  $z_{d,M}$  are design variables,  $R_{t,0}$  and  $R_m$  resistances (tension strength and bending moment capacity),  $\sum_i S_{t,i}$  and  $\sum_i S_{m,i}$  are the sum of load effects (axial forces and bending moments) and  $X_M$  the model uncertainty.

Typical serviceability limit state equation [Köhler et al, 2007] can be expressed as:

$$g(t) = \delta_L - W_\Delta \left( \sum S_i, E_{0,mean}, t \right) X_M = 0 \quad (3.41)$$

where  $\delta_L$  allowable deflection limit,  $W_\Delta(\sum S_i, E_{0,mean}, t)$  is the deflection in time  $t$ , dependant on load effects  $\sum S_i$  and modulus of elasticity  $E_{0,mean}$ .

## 4. UPDATING METHODS

### 4.1 INTRODUCTION

Although updating structural models or material properties is used in new construction, this procedure's potential is better suited for the assessment of the reliability of existing structures. When dealing with existing structures, updating of information may be regarded as a very important tool in the assessment of its reliability parameters. Updating is based on *prior information* and collected observations and measurements, such as visual inspection or tests results. It then results in *posterior information* used for the reliability assessment of the structure [JCSS, 2001b]. From this updated model, decisions upon the life-cycle reliability of existing structures may be taken and maintenance or strengthening actions may be considered.

In new construction, structural engineers often deal with the question of choosing between different types of structural configurations and materials in order to attain the better performance possible for a determined building or construction regarding, as well, to economical costs. In many occasions, these designers rely on the information given by the material manufacturer and / or distributor, and on compliance documents of the material. Designers also require doing conformity tests on the material, so to better know its limits and characteristics and to evaluate if that batch of material is actually in accordance with the compliance documents. Regarding the results of these conformity tests, it may be possible to update the characteristics used in the structural model for design and, thus, improving the accuracy of that model and permitting a better performance and durability of the new structure.

As already mentioned, the new updating data may result from different sources. One of great interest, for assessment of existing structures, is the information gathered from inspections. Inspection is an investigation intended to update the knowledge about the present condition of the structure [JCSS, 2001b]. Regarding each case in specific, different inspection approaches are taken attending to the nature of the inspection (what kind of inspection will be performed, which parameters to be measured and with what techniques and equipment) and the expected results and actions to be taken (do nothing, maintenance, repair, strengthening, further inspections, demolition, etc). Regardless of the inspection technique, two types of inspection can in general be distinguished: (i) qualitative inspection related to visual observation of different parameters or to comparison methods; (ii) quantitative inspection related to a set of values of parameters that define the condition of the structural elements. The uncertainties related to each of the inspection types (probability to detect some damage, accuracy and precision of results, human error, etc) must be specified and taken into account in the reliability assessment.

Further on this topic, it will be described how to update stochastic models and estimate its consequent reliability in terms of probability of failure. For that purpose, the updating method will be detailed when the new information derives from:

- Observation of events described by one or more stochastic variables, where the observation is modelled by an event margin and the failure event by a safety margin;
- Samples / measurements of a stochastic variable  $X$ .

### 4.2 UPDATING METHODS CONCEPTS

When assessing existing structures a manifold of information may be gathered from several distinct sources, which may be available or can be made available at a given cost. Qualitative together with quantitative information may allow defining the general condition of an existing structure, such as:

- The structure level of deterioration (if the structure has survived till present days);
- The structure level of damage;
- Material and physical characteristics;
- Geometrical surveying;
- Load bearing capacity by load tests or similar;
- Static and dynamic response (natural frequencies, modal shapes, damping coefficient, etc).

As previously mentioned, in the assessment of existing structures, these new information can be taken into account and combined with *prior* probabilistic models resulting in so-called *posterior* probabilistic models.

However, not all structures are suitable for every type of inspection technique. Historical structures, due to their social and cultural value are not prone to invasive or non reversible inspection techniques. For those structures, the following phases should be accomplished in order to obtain a full inspection and diagnosis, and consequently to gather data for model upgrading [Ramos, 2010]:

- Historic survey;
- Visual inspections;
- Foundations inspection;
- Non Destructive Testing (NDT);
- Minor Destructive Testing (MDT);
- Load tests;
- Monitoring;
- Structural analysis,
- Report with the conclusions and recommendations for the intervention / maintenance.

Regarding design assisted by results taken from testing, Eurocode 0 Annex D [CEN, 2002a] provides different procedures to statistically determine a single property, in terms of design and characteristic value, and also provides information to statistically determine resistance models with use of additional *prior* information.

The next subtopics are related to implementation techniques required to update data into stochastic models for reliability assessment.

#### **4.2.1 Bayesian methods**

Throughout their lifetime, structures change due to many aspects from natural causes (such as material deterioration, environment exposure and long term effects of loads in structures), to human decisions (such as modification of the structure or changing of use) or even by accidental actions, only to point a few. Thus, the assessment of existing structures should be regarded as a successive process of model updating and consequent evaluation regarding new information. The Bayesian probabilistic assessment for structures is illustrated schematically in Figure 4.1.

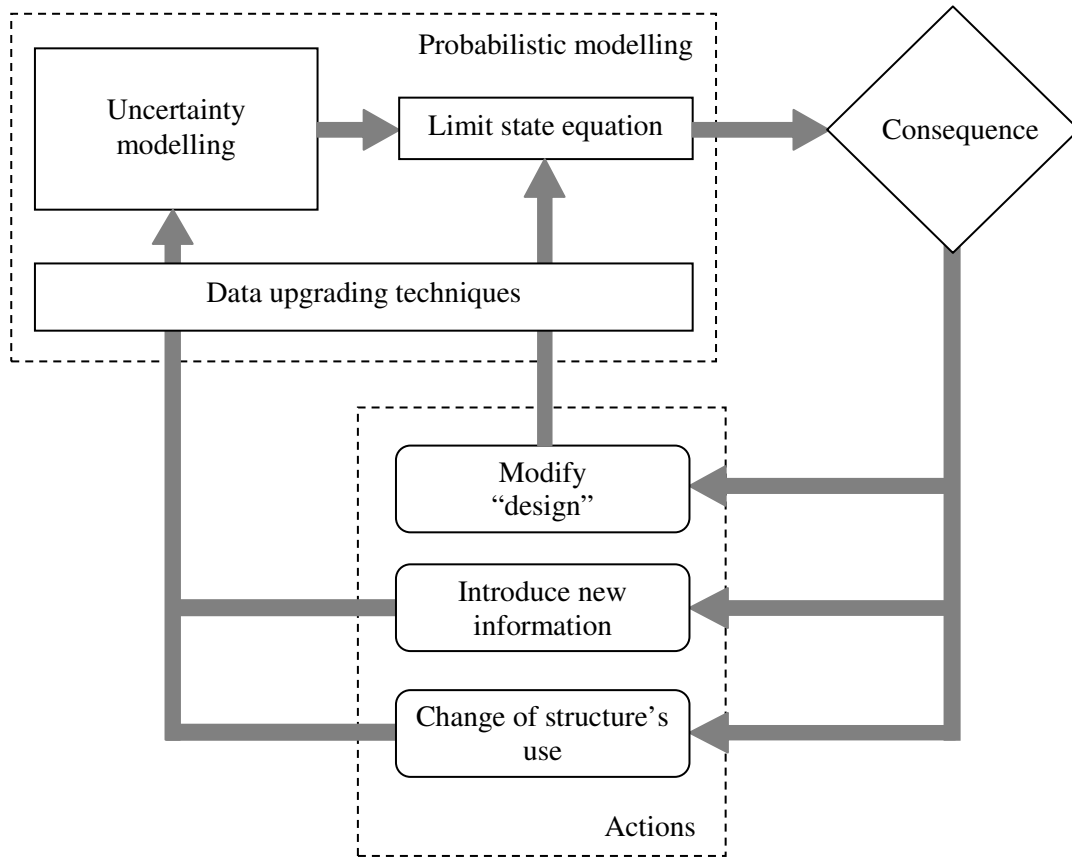

Figure 4.1: Bayesian probabilistic assessment for structures, adapted from JCSS [2001b]

When the source of new information is given by observation of events described by one or more stochastic variables, the observed events are modelled by an event function  $h$  introduced as:

$$H = h(X) \quad (4.1)$$

where the event function  $h$  corresponds to the limit state function. The actual observations are considered as realizations (samples) of stochastic variable  $H$ . These observations are then modelled by comparison with a certain limit by inequality events, such as  $H \leq 0$ , or by equality events, such as  $H = 0$ .

When inequality events are used, the updated probability of failure is estimated by:

$$P_F^U = P(g(X) \leq 0 | h(X) \leq 0) = \frac{P(g(X) \leq 0 \cap h(X) \leq 0)}{P(h(X) \leq 0)} \quad (4.2)$$

where  $M = g(X)$  is the safety margin related to the limit state function  $g(X)$  and  $X = (X_1, \dots, X_n)$  are stochastic variables.

When equality events are used, the updated probability of failure is estimated by:

$$P_F^U = P(g(X) \leq 0 | h(X) = 0) = \frac{P(g(X) \leq 0 \cap h(X) = 0)}{P(h(X) = 0)} = \frac{\frac{\partial}{\partial z} P(g(X) \leq 0 \cap h(X) \leq z) \Big|_{z=0}}{\frac{\partial}{\partial z} P(h(X) \leq z) \Big|_{z=0}} \quad (4.3)$$

For reliability evaluation of both inequality and equality events it is possible to implement either simulation or FORM methods.

Bayesian methods allow quantifying an approximation about the statistical uncertainty related to the estimated parameters, regarding both the physical uncertainty of the considered variable as well as the statistical uncertainty related to the model parameters and. Therefore they offer a suitable method for parameter estimation and model updating. However, for making this possible, it is necessary to take into account the measurement and the model uncertainties in the probabilistic model formulation.

Since Bayesian methods grant the opportunity to incorporate different considerations about the uncertainty of models in the upgraded stochastic model, the comparison between different reassessment engineers' results may be regarded as a problem, such that a consensus about a comparison basis has not yet been established.

#### 4.2.2 Prior, posterior and predictive distributions

When samples or measurements of a stochastic variable  $X$  are provided, the probabilistic model may be updated and, thus, also the probability of failure. Considering a stochastic variable  $X$  with density function  $f_X(x)$ , and if  $q$  denotes a vector of parameters defining the distribution for  $X$ , the density function of the stochastic variable  $X$  can be derived as:

$$f_X(x, q) \quad (4.4)$$

In the case that  $X$  is normally distributed then  $q$  may enclose the mean and the standard deviation of  $X$ .

When the parameters  $q$  are uncertain then  $f_X(x, q)$  can be considered as a conditional density function:  $f_X(x|Q)$  and  $q$  denotes a measurement of  $Q$ . The initial density function for the parameters  $Q$  is denoted  $f_Q'(q)$  and is termed the *prior* density function.

Taking into account the source of new information, it is assumed that  $n$  observations or measurements of the stochastic variable  $X$  are available making up a sample  $\hat{x} = (\hat{x}_1, \hat{x}_2, \dots, \hat{x}_n)$ . Each measurement is assumed to be independent. The updated density function  $f_Q''(q|\hat{x})$  of the uncertain parameters  $Q$  given the realizations is denoted the *posterior* density function and is given by:

$$f_Q''(q|\hat{x}) = \frac{f_N(\hat{x}|q)f_Q'(q)}{\int f_N(\hat{x}|q)f_Q'(q) dq} \quad (4.5)$$

where  $f_N(\hat{x}|q) = \prod_{i=1}^n f_X(\hat{x}_i|q)$  is the probability density at the given observations assuming that the distribution parameters are  $q$ . The integration in Eq. (4.5) is over all possible values of  $q$ .

Then the updated density function of the stochastic variable  $X$  given the realization  $\hat{x}$  is denoted the *predictive* density function and is defined by,

$$f_X(x|\hat{x}) = \int f_X(x|q) f_Q''(q|\hat{x}) dq \quad (4.6)$$

Given the distribution function for the stochastic variable  $X$ , the *prior* distribution is often chosen such that the *posterior* distribution will be of the same type as the *prior* distribution.

According to the type of existing and new information, different types of distributions may be attributed to characterize these data. Depending of the sensitivity and experience of the reassessment engineer responsible for the reliability analysis, different assumptions may be taken. In one hand, the information must be considered in such way that it is described appropriately and accurately. In the other hand, data must also be considered properly so the costs of computation and processing are



equivalent to the importance of the analysis. Therefore, *prior* and *posterior* distributions are many times chosen accordingly to the data available and to the importance of the analysis. Normal or also called Gaussian distributions are often used for that purpose, and so an example will be considered further on. Other examples of *prior*, *posterior* and predictive distributions may be found in Annex A.

In Annex D of Eurocode 0 [CEN, 2002a], information is provided for several procedures mainly related to design assisted by testing. In this topic, focus will be given for the general principles for statistical evaluations regarding the determination of single properties and resistance models. In Eurocode 0 [CEN, 2002a], normal distributions are often used, however, in general this may lead to conservative results. The choice of other distributions, such as lognormal or Weibull, will eventually give more suitable results if their use may be justified on basis of previous experimental experience. Regarding the generalized use of normal distributions, an example for a resistance model is given below [CEN, 2002a].

### **Example**

Consider a resistance model  $R$  with a normal distribution characterized by mean value  $\mu$  and standard deviation  $\sigma$ . The *prior* distribution is now denoted  $f_R'(\mu, \sigma)$  and is considered to be defined as:

$$f_R'(\mu, \sigma) = k\sigma^{-(\nu'+\delta(n')+1)} \exp\left(-\frac{1}{2\sigma^2}(v'(s')^2 + n'(\mu - m')^2)\right) \quad (4.7)$$

with:

$$\delta(n') = 0 \text{ for } n' = 0 \quad (4.8a)$$

$$\delta(n') = 1 \text{ for } n' > 0 \quad (4.8b)$$

The *prior* information about the standard deviation  $\sigma$  is given by parameters  $s'$  and  $\nu'$ . The expectation and coefficient of variation of  $\sigma$  can asymptotically (for large  $\nu'$ ) be expressed as:

$$E(\sigma) = s' \quad (4.9a)$$

$$V(\sigma) = \frac{1}{\sqrt{2\nu'}} \quad (4.9b)$$

The *prior* information about the mean  $\mu$  is given by parameters  $m'$ ,  $n'$  and  $s'$ . The expectation and coefficient of variation of  $\mu$  can asymptotically (for large  $\nu'$ ) be expressed as:

$$E(\mu) = m' \quad (4.10a)$$

$$V(\mu) = \frac{s'}{m'\sqrt{n'}} \quad (4.10b)$$

Another possible way to interpret the *prior* information is to consider the results of hypothetical prior test series, for mean and standard deviation analysis. For that case the standard deviation is characterized by:

- $s'$  is the hypothetical sample value;
- $\nu'$  is the hypothetical number of degrees of freedom for  $s'$ .

The information about the mean is given by:

- $m'$  is the hypothetical sample average;
- $n'$  is the hypothetical number of observations for  $m'$ .

Usually for a test it is considered that  $\nu = n - 1$ , but the *prior* parameters  $n'$  and  $\nu'$  are independent from each other.

The consideration of these parameters allows defining the expected values of mean and standard deviation of the *prior* information, and also permits to consider the degree of uncertainty related to those values. For low or lack of information,  $n'$  and  $\nu'$  are to considered equal to zero, whereas when almost deterministic knowledge of the mean and standard deviation is available this will lead to higher values of  $n'$  and  $\nu'$  (i.e. 20 or 40).

When new information is available, the resultant model given by the *prior* distribution  $f_R'(\mu, \sigma)$  may be updated according to Eq. (4.5), with the parameters:

$$n'' = n' + n \quad (4.11a)$$

$$\nu'' = \nu' + \nu + \delta(n') \quad (4.11b)$$

$$m''n'' = n'm' + nm \quad (4.11c)$$

$$\nu''(s'')^2 + n''(m'')^2 = \nu'(s')^2 + n'(m')^2 + \nu s^2 + nm^2 \quad (4.11d)$$

Assuming, as previously mentioned, that  $\nu = n - 1$  and that  $\delta(n')$  is given by Eq. (4.8).

With this procedure and taking into account Eq. (4.6) the predictive value of the resistance R is given by:

$$f_R = m'' - t_{\nu''} s'' \sqrt{\left(1 + \frac{1}{n''}\right)} \quad (4.12)$$

where  $t_{\nu''}$  has a central t-distribution as given in Table B.1 in Annex B. The appropriate choice of value for  $t_{\nu''}$  makes possible the calculation of characteristic values, each are often in Eurocodes given as the fifth percentile for resistance and 95<sup>th</sup> or 98<sup>th</sup> for loads.

For this case, a study upon the influence of the number of sampling test pieces of new information in the resultant characteristic value was regarded. For this purpose it was considered that:

- new information was gathered from a trial of tests. The number of test pieces  $n$  is the focus of this study. The sample mean  $m$  is equal to 75 kN and the sample standard deviation  $s$  is equal to 15 kN. Let us consider, on a first step, that both  $m$  and  $s$  are constant regardless of the number of test pieces  $n$ , although physically not coherent;
- from *prior* information the sample mean was equal to 80 kN, but with high variation. The standard deviation  $s'$  is equal to 17 kN with a coefficient of variation of 25%.

By varying the number of test pieces  $n$  the characteristic value for resistance  $R_k$  is influenced as shown in Figure 4.2. From the analysis of that graphic, it is concluded that, in a first stage an increase of the number of test pieces is highly advantageous because, even a small increase in  $n$ , produces a large increase in  $R_k$ . However, this curve tends to stabilize in a horizontal asymptote and, thus, even high increments of  $n$  lead to small increments of  $R_k$ . Although, as previously mentioned, the assumption of constant mean and standard deviation for different values of  $n$  may be found questionable, the value of this preliminary study is found when dealing with cost assessment when defining the number of necessary tests.

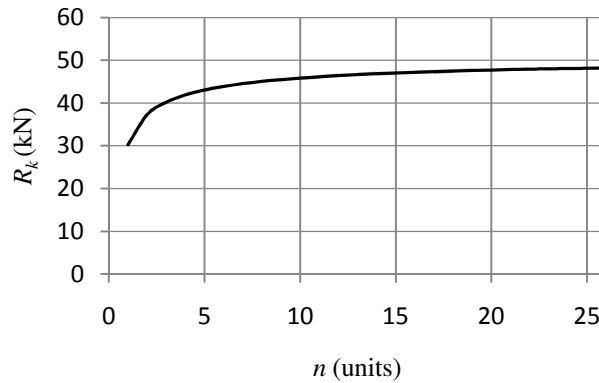
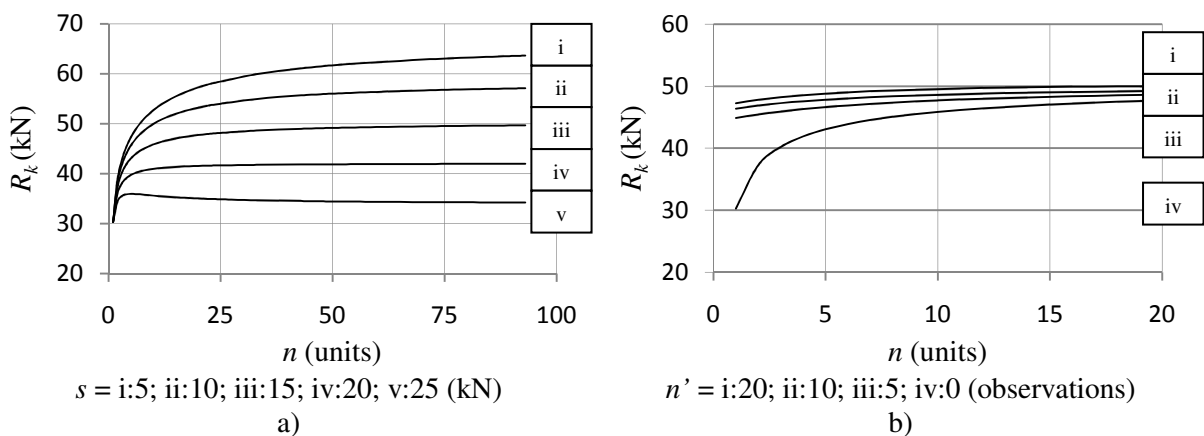

Figure 4.2: Variation of the characteristic value for resistance with number of test pieces.

For the same example, a study was conducted to assess the importance of different parameters regarding the characteristic resistance versus number of test samples. The results are presented in Figure 4.3. From the results, the following conclusions were taken for this example:

- by varying the standard deviation of the new information  $s$  (Figure 4.3.a) it is observed that the values of  $R_k$  are very influenced. For lower values of  $s$  the values of  $R_k$  increase towards the value of  $m$ . The values of  $R_k$  tend to stabilize for minor values of  $n$  in a faster way when the values of  $s$  increases, concluding that for smaller  $s$  the gain in  $R_k$  is further available with more test samples;
- by varying the hypothetical number of samples for  $m'$  and therefore the uncertainty related to this parameter (Figure 4.3b) it is observed that, for even small increases of this parameter  $n'$  the gain in  $R_k$  is high for small numbers of  $n$ . Nevertheless, for higher numbers of  $n$  the importance of  $n'$  is less significant because  $n'' = n' + n$ ;
- when varying the value of the coefficient of variation for the standard deviation of the *prior* information (Figure 4.3c) it is noticed, that no significant changes were caused to the  $R_k$  versus  $n$  graph;
- for different levels of  $n'$  the importance of  $m'$  (Figures 3.4d, e, f) was observed to be higher for lower levels of  $n$ , but as seen before the relation  $n'' = n' + n$  leads to smaller influence of  $n'$  as  $n$  increases. This also results in a smaller influence of  $m'$  as the influence of  $n'$  decreases.

The main conclusion is that an increase on the number of test samples or a decrease on the uncertainty related to either or both *prior* and new information will eventually lead to similar results. Therefore, both ways must be compared in terms of effectiveness and cost optimization in order to obtain a more adequate procedure for data upgrading.



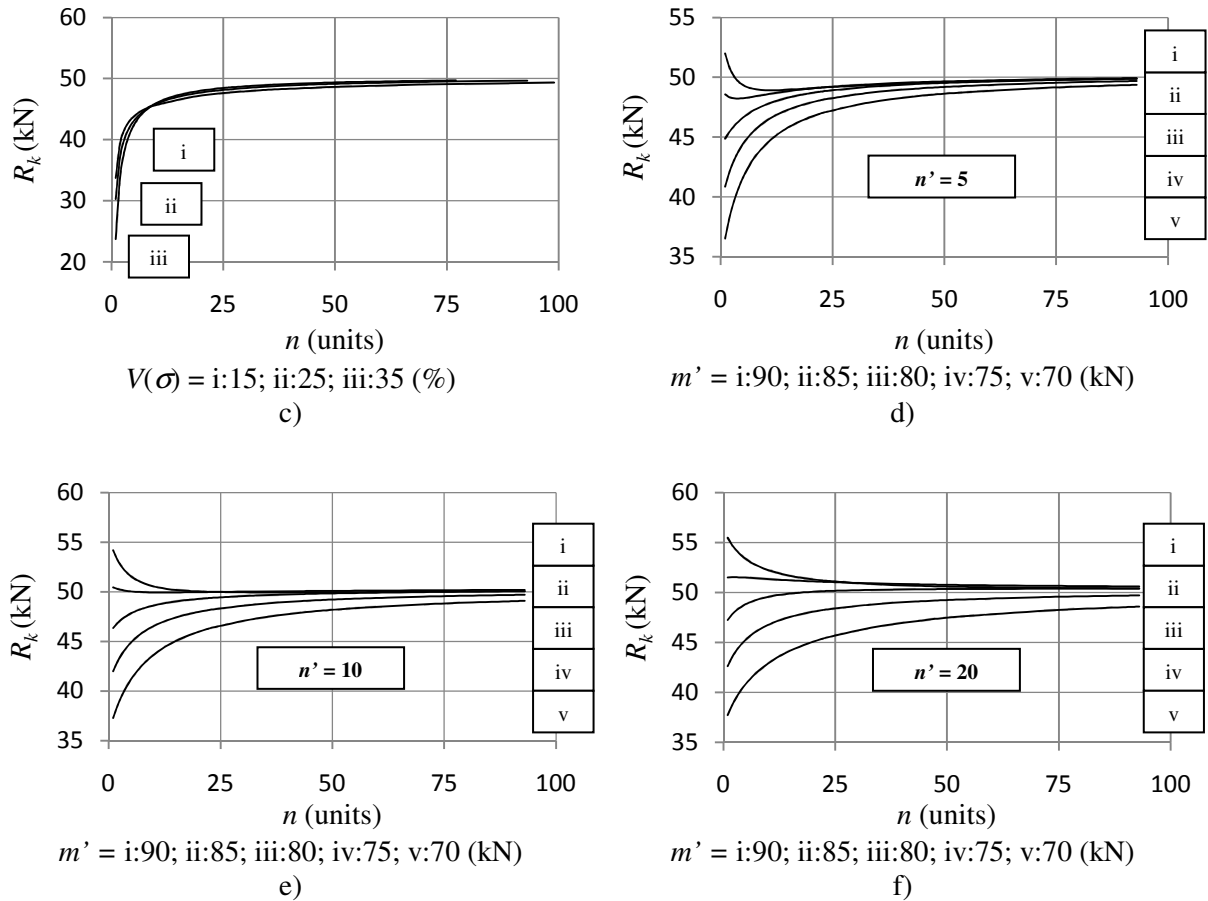

Figure 4.3: Results for multi-parameter analysis regarding characteristic resistance  $R_k$  versus number of test samples  $n$

Also the observation of this example might prove its importance when considering a quality control scheme. As stated in JCSS [1996], the Eurocode 0, Annex D [CEN, 2002a] provides an estimation of the characteristic value of a batch, given that the batch passes a certain quality control procedure, which may be in most cases too conservative. The reason for this statement is found when considering that, due to continuous quality controls, *prior* information is well defined and also the producer aims at a very small fraction of rejected batches. So, as previously seen, a better definition of the *prior* knowledge of the production characteristic allows increasing the characteristic resistance value.

The above updating procedure is straightforward when *prior* information is fully or well known. Nevertheless, this is not always the most common situation and many times only vague or scarce information is available. When standard deviation  $\sigma$  is known but vague *prior* information is offered, the parameters are given as:

- $n' = 0$ ;
- $v' = \infty$ ;
- $m' = \text{not relevant}$ ;
- $s' = \sigma$

Considering  $n$  observations with mean value  $m$  the updating parameters become:

- $n'' = n$ ;
- $v'' = \infty$ ;
- $m'' = m$ ;
- $s''^2 = \sigma^2$

With this procedure and taking into account Eq. (4.6) the predictive value of the resistance  $R$  is now given by:

$$f_R = m - t_{\infty} \sigma \sqrt{\left(1 + \frac{1}{n}\right)} \quad (4.13)$$

where  $t_{\infty}$  has a central t-distribution as given in Table B.1 in Annex B for row corresponding to  $\nu' = \infty$ .

When standard deviation  $\sigma$  is also unknown and vague *prior* information is offered, the parameters are given as:

- $n' = 0$ ;
- $\nu' = 0$ ;
- $m' = \text{not relevant}$ ;
- $s' = \text{not relevant}$

Considering  $n$  observations with mean value  $m$  and standard deviation  $s$ , the updating parameters become:

- $n'' = n$ ;
- $\nu'' = n-1$ ;
- $m'' = m$ ;
- $s''^2 = s^2$

With this procedure and taking into account Eq. (4.6) the predictive value of the resistance  $R$  is now given by:

$$f_R = m - t_{n-1} s \sqrt{\left(1 + \frac{1}{n}\right)} \quad (4.14)$$

where  $t_{n-1}$  has a central t-distribution as given in Table B.1 in Annex B for row corresponding to  $\nu' = n-1$ .

Although normal distributions are relatively easier to implement than other more complicated probabilistic distributions, sometimes restraints or restrictions may make necessary the use of other distributions. Lognormal distributions are often associated to resistance models because no negative values are possible. The evaluation based on a lognormal distribution is in some occasions also simple. Let us consider the above example and a number of observations  $X$  with lognormal distribution, so that  $Y = \ln(X)$  has a normal distribution. Then, for the case of vague *prior* information on the mean or, on both mean and standard deviation the updating scheme goes as follows, regarding that  $Y$  is defined by:

$$m(Y) = \frac{1}{n} \sum_{i=1}^n Y_i \quad (4.15a)$$

$$s(Y)^2 = \frac{1}{n-1} \sum_{i=1}^n (Y_i - m(Y))^2 \quad (4.15b)$$

with  $Y_i = \ln(X_i)$ .

Then the predictive function for a design value is stated as:

$$X_d = \exp(m(Y)) \exp\left(t_{vd}s(Y) \sqrt{1 + \frac{1}{n}}\right) \quad (4.16)$$

where  $t_{vd}$  has a central t-distribution as given in Table B.1 in Annex B.

Although there is a useful number of distribution types of great importance for several reliability based structural reassessment, not all practical situations allow for an analytical solution. In this case, FORM techniques to integrate over the possible outcomes of the uncertain distribution parameters are possible, and by this, permitting to assess the predictive distribution [Madsen et al, 1986].

### 4.3 UPDATING BASED ON INSPECTION OF DETERIORATION

Buildings, structures or even single structural elements are exposed to several aggressive agents and damage to its structural integrity may derive from different sources. Deterioration may occur in a slow time process such as aging induced by environmental aggressive agents. In this context, it is imperative to assess both the performance in serviceability as well as the safety conditions in ultimate limit state, of a structure throughout its service life.

In order to assess and confirm that a structure is adequately performing its purposes, degradation must be inspected and controlled. Regular inspections and monitoring of the structural response to the environmental and loading conditions can pose as efficient alternatives for degradation control and assessment.

For example, in Sousa et al [2010] a study was conducted in order to assess the safety level of four timber trusses based in information gathered from visual inspection and results of NDT's and MDT's. With this information different geometrical models for the cross-section of the trusses' elements were proposed and ultimately reliability indices were found for each case. Also time degradation curves were considered assuming a deterioration model [Wang et al, 2008 and Leicester, 2001]. For the purpose of this work, it is worthwhile noticing that the inspection of the deterioration of the timber structures lead to a better knowledge and definition of the actual safety level of the timber structures.

Also, updating based on inspection of deterioration may be regarded as a conditioning updating, since it may be used for the calculation of conditional probabilities of failure due to *in-situ* measurements. Therefore, one may extrapolate a model to predict the evolution of the probability of failure along time and then adjust this model with data based on inspection of deterioration.

Nevertheless, when dealing with inspection data, it is important to take the uncertainty of the inspection methods into account. The inspection uncertainty may adequately be modelled in terms of the Probability of Detection (POD) and the Probability of Sizing (POS). The POD models the event that the inspection methods miss a defect of a given size, where the POS models the measurement uncertainty given a defect was found [JCSS, 2001b]. This allows updating the probability of failure due to a deterioration phenomenon  $d$  as:

$$P(d_{crit} - d(n) \leq 0 | d(n) - POD \leq 0) = \frac{P(d_{crit} - d(n) \leq 0 \cap d(n) - POD \leq 0)}{P(d(n) - POD \leq 0)} \quad (4.17)$$

where  $d(n)$  is the value of a given deterioration phenomenon at a given time period  $n$ ,  $d_{crit}$  is the critical value related to the deterioration phenomenon  $d$  and POD is the probability of detection due to the used inspection method.

## 5. ROBUSTNESS

### 5.1 INTRODUCTION

From the past few decades, an increased interest in robustness has been shown by many structural researchers. Although robustness has always presented a area of interest, recent events such as the progressive collapse of the Ronan Point building in London, 1968, due to a gas explosion or the total collapse of the Twin Towers of World Trade Centre in New York, 2001 (Figure 5.1), due to terrorist activity, have pushed further this interest.



Figure 5.1: Structural collapses of buildings: a) Ronan Point building partial collapse; b) Twin Towers total collapse after terrorist attack

Also structural failures have occurred concerning glued laminated timber (glulam) structures, which have brought new interest and attention from designers and safety reassessment engineers. Some examples are the Siemens Arena, Ballerup, Denmark; Bad Reichenhall Ice-Arena, Bavaria, Germany (Figure 5.2) and the exhibition hall in Jyväskylä, Finland, where design and conception errors led to disproportionate failures.



Figure 5.2: Structural collapses of glulam structures: a) Siemens Arena roof [Munch-Andersen e Dietsch, 2009]; b) Bad Reichenhall Ice-Arena, [Dietsch et al, 2009]

In the Siemens Ballerup Arena, two of twelve main trusses failed and since only a partial failure was present, the roof may be considered as robust system. However, the same is not true for the Bad Reichenhall Ice-Arena, where a total collapse of the roof does not allow it to be considered as a robust system [Vrouwenvelder and Sørensen, 2009].

However, a common general agreement has not yet been achieved, in terms of definition, how to define a structure as robust and how to achieve such property in design and construction phases. Therefore the concept of robust structures is still an issue of controversy since there are no well established and generally accepted criteria for a consistent definition and a quantitative measure of structural robustness. Nevertheless, it is often considered that structural robustness can be viewed as

the ability of the system to suffer an amount of damage not disproportionate with respect to the causes of the damage itself [Biondini, 2008].

Several codes present slightly different definitions for robustness, such as:

- ISO 22111 [ISO, 2007]: Ability of a structure (or part of it) to withstand events (like fire, explosion, impact) or consequences of human errors, without being damaged to an extent disproportionate to the original cause;
- Eurocode 1, part 1.7 [CEN, 2006]: The ability of a structure to withstand events like fire, explosions, impact or the consequences of human error, without being damaged to an extent disproportionate to the original cause;
- SIA 260 [SIA, 2004]: Ability of a structure and its members to keep the amount of deterioration or failure within reasonable limits in relation to the cause.

The common denominator of the above definitions is clear, such as all of them describe robustness based on a relationship between an event and its subsequent consequences.

## 5.2 FRAMEWORK FOR ROBUSTNESS OF STRUCTURES

The following framework is based in the bibliography compilation found in Kirkegaard and Sørensen [2009].

Most building codes often assume the same principles for robust structures as those proposed by the requirements of Eurocodes EN 1990 [CEN, 2002a] and EN 1991 part 1.7 [CEN, 2006]. Those documents state that a structure shall be “designed in such a way that it will not be damaged by events like fire, explosions, impact or consequences of human errors, to an extent disproportionate to the original cause” and also mentions that potential damage shall be avoided by “avoiding, eliminating or reducing the hazards to which the structure can be subjected; selecting a structural form which has low sensitivity to the hazards considered; selecting a structural form and design that can survive adequately the accidental removal of an individual member or a limited part of the structure, or the occurrence of acceptable localized damage; avoiding as far as possible structural systems that can collapse without warning; tying the structural members together”

EN 1991 part 1.7 [CEN, 2006] provides strategies and methods to obtain robustness. Actions that should be considered in different design situations are: 1) designing against identified accidental actions, and 2) designing against unidentified actions (where designing against disproportionate collapse, or for robustness, is important).

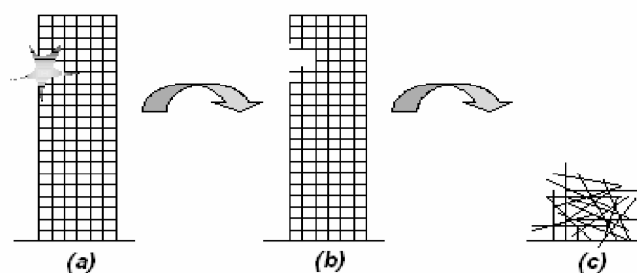

Figure 5.3: Illustration of the basic concepts in robustness [CEN, 2006].

The basic concepts in robustness are illustrated in Figure 5.3, such as:

- a) Exposures which could be unforeseen unintended effects and defects (including design errors, execution errors and unforeseen degradation) such as:
  - unforeseen action effects, including unexpected accidental actions;



- unintended discrepancies between the structure's actual behaviour and the used design models;
  - unintended discrepancies between the implemented project and the project material;
  - unforeseen geometrical imperfections;
  - unforeseen degeneration.
- b) Local damage due to exposure (direct consequence of exposure)
- c) Total (or extensive) collapse of the structure following the local damage (indirect consequence of exposure)

Robustness requirements are especially related to step from b) to c), i.e. how to avoid that a local damage develop to total collapse, i.e. robustness is meant to avoid failures caused by errors in the design and construction, lack of maintenance and unforeseeable events.

As previously mentioned, the interest in the development of methods to assess robustness and to quantify aspects of robustness has increased in the last decades. An overview of these methods is given in Baker et al [2008]. The basic and most general approach is to use a risk analysis where both probabilities and consequences are taken into account. Approaches to define a robustness index can be divided in the following levels with decreasing complexity [Vrouwenvelder and Sørensen, 2009]:

- A risk-based robustness index based on a complete risk analysis where the consequences are divided in direct and indirect risks;
- A probabilistic robustness index based on probabilities of failure of the structural system for an undamaged structure and a damaged structure;
- A deterministic robustness index based on structural measures, e.g. pushover load bearing capacity of an undamaged structure and a damaged structure.

Since a structure may present different failures mechanisms between its initial and final states, there is no consensus for the evaluation of the potential for a disproportionate or progressive failure, as well as not for a level of robustness [Ellingwood, et al 2007]. Nevertheless, some steps may be implemented in a design stage, in order to provide a better structural behaviour in the event of loss of structural element(s). These steps mostly intend to reduce the risk of disproportionate collapse, after failure of specific element(s). There are, in general, three alternative approaches for structural design in order to reduce their susceptibility to disproportionate collapse [Nair, 2006]:

- Redundancy or alternate load paths;
- Local resistance; and
- Interconnection or continuity.

These traits are further explained and complemented as [Ellingwood, et al 2007]:

- *Redundancy*: incorporation of redundant load paths in the vertical load carrying system.
- *Ties*: using an integrated system of ties in three directions along the principal lines of structural framing.
- *Ductility*: structural members and member connections have to maintain their strength through large deformations (deflections and rotations) so the load redistribution(s) may take place.
- *Adequate shear strength*: as shear is considered as a brittle failure, structural elements in vulnerable locations should be designed to withstand shear load in excess of that associated with the ultimate bending moment in the event of loss of an element.
- *Capacity for resisting load reversals*: the primary structural elements (columns, girders, roof beams, and lateral load resisting system) and secondary structural elements (floor beams and slabs) should be designed to resist reversals in load direction at vulnerable locations.
- *Connections (connection strength)*: connections should be designed in such way that it will allow uniform and smooth load redistribution during local collapse
- *Key elements*: exterior columns and walls should be capable of spanning two or more stories without bucking, columns should be designed to withstand blast pressure etc.

- *Alternate load path(s)*: after the basic design of structure is done, a review of the strength and ductility of key structural elements is required to determine whether the structure is able to “bridge” over the initial damage.

These characteristics are suitable to be used for designing against identified accidental actions, and designing against unidentified actions according to EN 1991 part 1.7 [CEN, 2006].

The concept of structural redundancy can be defined as the ability of the system to redistribute among its members the load which can no longer be sustained by some other damaged members [Biondini et al, 2008]. This often leads to consider that structural robustness and redundancy are associated with the degree of static indeterminacy. However, the degree of static indeterminacy is not a consistent measure for structural robustness and redundancy [Biondini et al, 2008].

### 5.3 METHODS TO ASSESS ROBUSTNESS

As previously mentioned, three main methods to assess robustness are usually used. More information regarding each method is given in this topic, based in the bibliography compilation found in Vrouwenvelder and Sørensen [2009].

#### 5.3.1 Risk-based robustness index

The concept of Figure 5.3 may be presented in a more general way employing an event tree as in Figure 5.4.

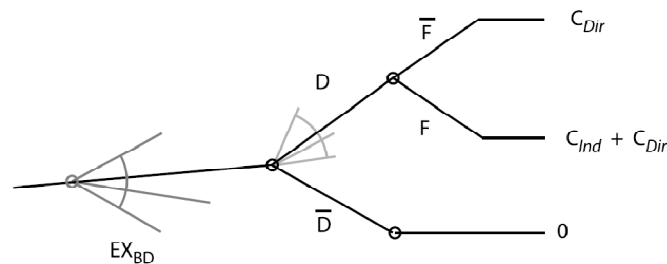

Figure 5.4: An event tree for robustness quantification [Baker et al. 2008].

The first step for assessment is the consideration and modelling of exposures,  $EX$ , that eventually can cause damage to the elements of the structural system. The term “exposures” is considered as seen for Figure 5.3a). The term “damage” refers to reduced performance or failure of individual components of the structural system. After the exposure event occurs, the event tree is divided into two branches regarding if the structural system remains in an undamaged state,  $\bar{D}$ , or a damaged state,  $D$ . For each damaged state a new set of branches are considered regarding the possibility of structural failure,  $F$ , or no failure,  $\bar{F}$ . Consequences are associated with each of the possible damage and failure scenarios, and are classified as either direct,  $C_{Dir}$ , or indirect  $C_{Ind}$ . Direct consequences are considered to result from damage states of individual component(s). Indirect consequences are incurred due to loss of system functionality or failure and can be attributed to lack of robustness [Baker et al, 2008 and JCSS, 2008].

The basic framework for risk analysis is based on the following equation with risk contributions from local damages (direct consequences) and comprehensive damages (follow-up / indirect consequences), are added, see Baker et al [2008] and JCSS [2008]:

$$R = \sum_i \sum_j C_{dir,ij} P(D_j|E_i) P(EX_i) + \sum_k \sum_i \sum_j C_{ind,ijk} P(S_k|D_j \cap EX_i) P(D_j|EX_i) P(EX_i) \quad (5.1)$$

where:

$C_{dir,ij}$  is the consequence (cost) of damage (local failure)  $D_j$  due to exposure  $EX_i$ ;

$C_{ind,ijk}$  is the consequence (cost) of comprehensive damages (follow-up / indirect)  $S_k$  given local damage  $D_j$  due to exposure  $EX_i$ ;

$P(EX_i)$  is the probability of exposure  $EX_i$ ;

$P(D_j|EX_i)$  is the probability of damage  $D_j$  given exposure  $EX_i$ ;

$P(S_k|...)$  is the probability of comprehensive damages  $S_k$  given local damage  $D_j$  due to exposure  $EX_i$ ;

The optimal design (decision) is the one minimizing the sum of costs of mitigating measures and the total risk  $R$ . A detailed description of the theoretical basis for risk analysis can be found in JCSS [2008]. It is noted that an important step in the risk analysis is to define the system and the system boundaries.

The total probability of comprehensive damages / collapse associated to Eq. (5.1) is:

$$P(\text{collapse}) = \sum_i \sum_j P(\text{collapse}|D_j \cap EX_i) P(D_j|EX_i) P(EX_i) \quad (5.2)$$

where  $P(\text{collapse}|D_j \cap EX_i)$  is the probability of collapse given local damage  $D_j$  due to exposure  $EX_i$ , which for damage related to key elements may be considered approximately equal to 1. From Eq. (5.2) is swiftly concluded that reducing any of the probabilities on the left side of that equation will lead to smaller probabilities of collapse. Robustness is mainly related to the reduction of the probability  $P(\text{collapse}|D_j \cap EX_i)$ .

Given this concept of risk in Baker et al [2008] a definition of a robustness index is proposed. The approach divides consequences into direct consequences associated with local component damage (that might be considered proportional to the initiating damage) and indirect consequences associated with subsequent system failure (that might be considered disproportional to the initiating damage). An index is formulated by comparing the risk associated with direct and indirect consequences. The index of robustness,  $I_{Rob}$ , is defined as:

$$I_{rob} = \frac{R_{Dir}}{R_{dir} + R_{Ind}} \quad (5.3)$$

where  $R_{Dir}$  and  $R_{Ind}$  are the direct and indirect risks associated with the first and the second term in Eq. (5.1). The index takes values between zero and one, with larger values indicating larger robustness. However a important remark should be attended, the optimal decision is the one which minimizes the total risk obtained by Eq. (5.1). This could equally well be by reducing the first or the second term in that equation. This implies that the definition of a robustness index by equation (5.3) is not always fully consistent with a full risk analysis, but should be considered as a possible helpful indicator.

### 5.3.2 Reliability-based robustness index

The work from Frangopol and Curley [1987] and Fu and Frangopol [1990] proposed some probabilistic measures related to structural redundancy – which may also be an indicator of the level of robustness in some occasions. A redundancy index,  $RI$ , is defined by:

$$RI = \frac{P_{f(dmg)} - P_{f(sys)}}{P_{f(sys)}} \quad (5.4)$$

where  $P_{f(dmg)}$  is the probability of failure for a damaged structural system and  $P_{f(sys)}$  is the probability of failure of an intact structural system. The redundancy index provides a measure on the robustness / redundancy of the structural system. They also considered the following related redundancy factor:

$$\beta_R = \frac{\beta_{intact}}{\beta_{intact} - \beta_{damaged}} \quad (5.5)$$

where  $\beta_{intact}$  is the reliability index of the intact structural system and  $\beta_{damaged}$  is the reliability index of the damaged structural system.

### 5.3.3 Deterministic robustness index

For example of a deterministic robustness index, a simple and practical measure of structural redundancy (and robustness) used in the offshore industry is presented. It is based on the so-called  $RIF$ -value (Residual Influence Factor) [ISO19902, 2007]. A reserve strength ratio (RSR) is defined as:

$$RSR = \frac{R_c}{S_c} \quad (5.6)$$

where  $R_c$  denotes the characteristic value of the base shear capacity of an offshore platform (typically a steel jacket) and  $S_c$  is the design load corresponding to ultimate collapse.

In order to measure the effect of full damage (or loss of functionality) of structural member  $i$  on the structural capacity the so-called  $RIF$ -value (sometimes referred to as the Damaged Strength Ratio) is defined:

$$RIF_i = \frac{RSR_{Fi}}{RSR_{intact}} \quad (5.7)$$

where  $RSR_{intact}$  is the  $RIF$ -value of the intact structure and  $RSR_{Fi}$  is the  $RIF$ -value of the structure where member no  $i$  is failed/removed. The  $RIF$  can vary between 0 and 1, where the larger  $RIF$  stand for a more robust structure.

Other simple measures of robustness have been proposed based on e.g. the determinant of the stiffness matrix of structure with and without removal of elements. A simply defined measure of robustness is proposed in Starossek and Haberland [2008].  $R_s$  denotes a stiffness based robustness measure defined as:

$$R_s = \min_j \frac{\det K_j}{\det K_0} \quad (5.8)$$

where  $K_j$  and  $K_0$  are the system stiffness matrix of the intact structure and the stiffness matrix after the removal of a structural element or a connection  $j$ , respectively. However, it is accepted that this

robustness measure is not sufficient in this form [Starossek and Haberland, 2008]. In the same work an energy based measure of robustness and a damage based measure of robustness are also proposed. The energy based measure is defined as:

$$R_s = 1 - \max_j \frac{E_{r,j}}{E_{s,k}} \quad (5.9)$$

where  $E_{r,j}$  is amount of energy released by the initial failure of a structural element  $j$  and available energy for the damage of the next structural element  $k$ , while  $E_{s,k}$  is the energy required for the failure of the next structural element.

The damage based measure of robustness is defined as:

$$R_s = 1 - \frac{p}{p_{lim}} \quad (5.10)$$

where  $p$  is the maximum extent of the damage caused by initial damage and  $p_{lim}$  is the acceptable damage progression [Starossek and Haberland, 2008].

Other measures are also referred in Biondini [2008], as it is stated that a measure of structural robustness should arise by comparing the structural performance of the system in the original state, in which the structure is fully intact, and in a perturbed state, in which a prescribed damage scenario is applied. The effectiveness of several performance indicators in evaluating structural robustness has been investigated in Restelli [2007]. Those indicators are associated with the properties of the structural system only, like eigenvalues and conditioning number of the overall stiffness matrix, and indicators also depending on the loading scenario, like stored energy, displacements, and vectors of nodal forces equivalent to the effects of damage (backward or forward pseudo-loads). All these indicators could be adopted as state variables affecting the robustness of a structural system [Biondini et al, 2008]. A direct measure of structural robustness within the range [0, 1] is then obtained through functions of such variables, that are robustness indices. A set of dimensionless robustness indices has been introduced in Restelli [2007]. An example of those indicators is shown in Eq. (5.11) for the case of the displacement vector:

$$\rho = \frac{\|s_0\|}{\|s_d\|} \quad (5.11)$$

where  $s$  is the displacement vector,  $\|\cdot\|$  denotes the euclidean scalar norm, and the subscripts “0” and “d” refer to the intact and damaged state of the structure, respectively.

## 6. EXAMPLE CASES / STUDY CASES

### 6.1 INTRODUCTION

In this chapter, practical examples are given regarding structural safety assessment of timber structures. Life-cycle structural reliability is mentioned with respect to deterioration models. Those models are then updated with consideration of different scenarios given by possible NDT and MDT results. Depending on different assumptions a reliability base robustness assessment is also proposed, with respect to time evolution of the decay process.

Firstly, a single element structure is proposed in order to introduce the basic concepts, thus, providing a first step between the theoretical concepts, given in the previous chapters, with simplified practical cases. The example is given by a simple supported beam with rectangular cross-section and exposed to different load combinations of permanent and live load.

A second example is also proposed with consideration to a column subjected to pure compression. The timber column has a square cross-section and is exposed to different load combinations of permanent and live load. After a design reliability analysis, an updating of the resistant model through NDT and MDT data is proposed. That data corresponds to correlations for  $f_{c,0}$  and NDT or MDT in Feio [2005] and its uncertainty is modelled through a Maximum Likelihood method.

### 6.2 EXAMPLE CASE A: SINGLE ELEMENT STRUCTURE

The first example consists in a simple supported beam exposed to different load combinations of permanent and live load. The loads are assumed uniformly distributed along the beam length ( $l$ ), as shown in Figure 6.1. The combination of loads is modelled as:

$$S = (1 - \alpha)G + \alpha Q \quad (6.1)$$

where  $G$  is the permanent load and  $Q$  is the variable load (in this case live load),  $\alpha$  is a factor between 0 and 1, modelling the relative fraction of variable load and permanent load.

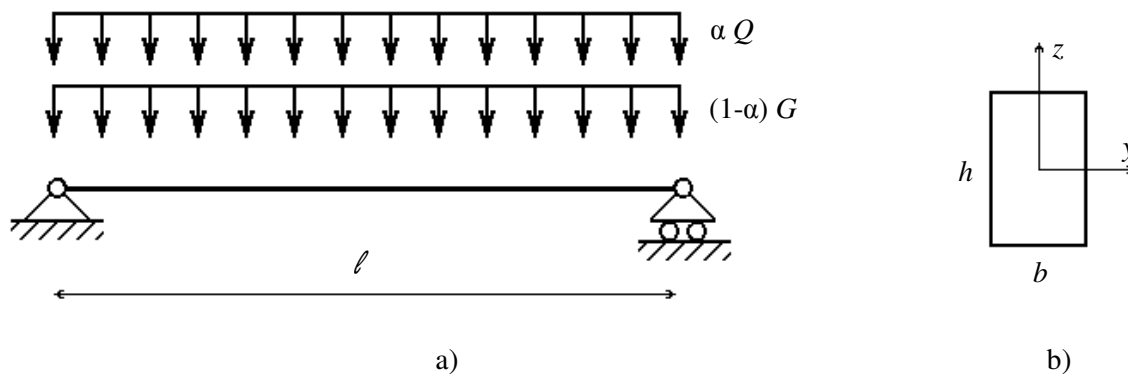

Figure 6.1: Single supported beam: a) structural model; b) cross-section

The beam is made of solid timber and considered to have a rectangular cross-section.

#### 6.2.1 Design by Eurocodes

For reliability assessment of this structure the fundamental load combination rule given by Eq. (6.10) of Eurocode 0 (CEN, 2002a) was assumed. Therefore, the characteristic values for resistance and load parameters were considered for the limit state equation. These values are also influenced by partial safety factors.

The limit state equation was considered to be related to the maximum bending moment at mid-span of the beam. The following limit state equation was used:

$$g = \frac{1}{6}bh^2 k_{mod} f_m - \frac{1}{8}l^2((1 - \alpha)G + \alpha Q) \quad (6.2)$$

and  $z$  is the design parameter assumed from the corresponding design equation and for this case considered to be the height,  $h$ , of the cross-section.  $h$  is chosen as design parameter and is obtained from:

$$\frac{1}{6}bh^2 k_{mod} \frac{f_{m,k}}{\gamma_m} - \frac{1}{8}l^2 \left( (1 - \alpha)G_k \gamma_G + \alpha Q \gamma_Q \right) \geq 0 \quad (6.3)$$

The  $k_{mod}$  parameter was considered by two different ways (Figure 6.2). The first method corresponded to a linear variation between 0.6 and 0.9, respectively to  $\alpha = 0$  and  $\alpha = 1$ , whereas the second method is given as suggested by Eurocode 5 (CEN, 2004) where  $k_{mod}$  is primarily dependant of the action with smaller duration.

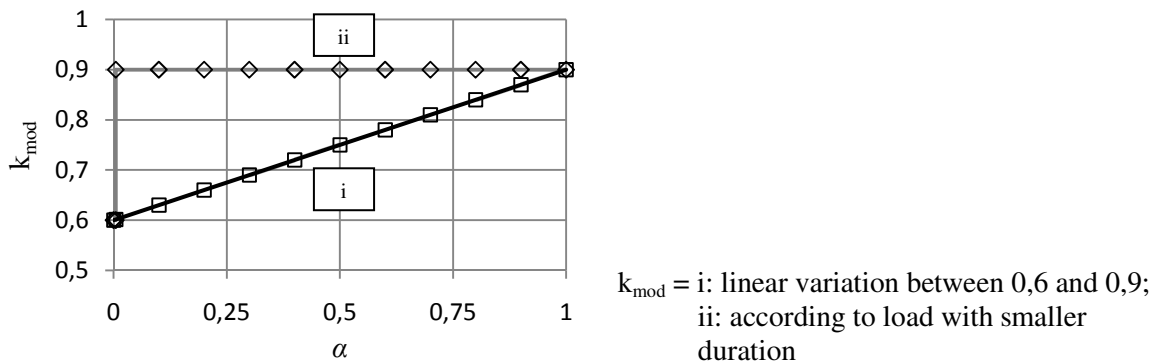

Figure 6.2: Different methods for  $k_{mod}$  consideration according to  $\alpha$

The reliability obtained with consideration to design of timber elements subjected to simple bending, as given in Eq. (6.11) of Eurocode 5 (CEN, 2004), is presented in Figure 6.3. The variables were defined as according to previously mentioned stochastic models and the values that were considered are presented in Table 6.1.

Table 6.1: Variables used in the stochastic model

Variable	Distribution	E [X]	COV[X]	Comment	Characteristic value
$f_m$	Lognormal	25 N/mm <sup>2</sup>	0.25	Bending strength	5%
$G$	Normal	6 N/mm	0.10	Permanent load	95%
$Q$	Gumbel	4 N/mm	0.40	Annual maximum live load	98%
$h$	Deterministic	design parameter	-	Height of the cross-section	-
$b$	Deterministic	200 mm	-	Width of the cross-section	-
$l$	Deterministic	6000 mm	-	Length of the beam	-
$\gamma_m$	Deterministic	1.3	-	Partial safety factor	-
$\gamma_G$	Deterministic	1.35	-	Partial safety factor	-
$\gamma_Q$	Deterministic	1.5	-	Partial safety factor	-

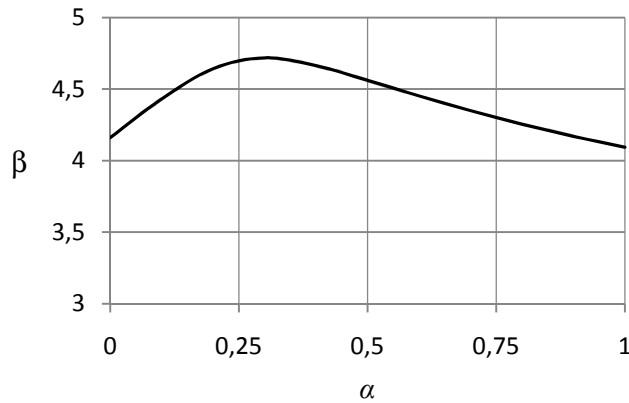

Figure 6.3: Reliability index with reference time one year regarding Eq. (6.11) of EC5 (CEN, 2004) for design of a single supported beam (stochastic models in Table 6.1)

The obtained reliability level was always above  $\beta = 4$ , reaching values higher than  $\beta = 4.6$  around  $\alpha = 0.3$ . The mean value found for reliability was approximately  $\beta = 4.4$  which is higher than the suggested in the PMC [JCSS, 2000] for 1 year reference period and reliability class 1.

According to different types of buildings and uses, different live load values may be applied to the design of a structure. In regard to that situation, the same analysis done above was conducted to different intensities of live load maintaining the permanent load equal for all cases. The factor  $G/Q$  represents a change in the expected value of the live-load, although maintaining the expected value for permanent load. The following figure presents the results.

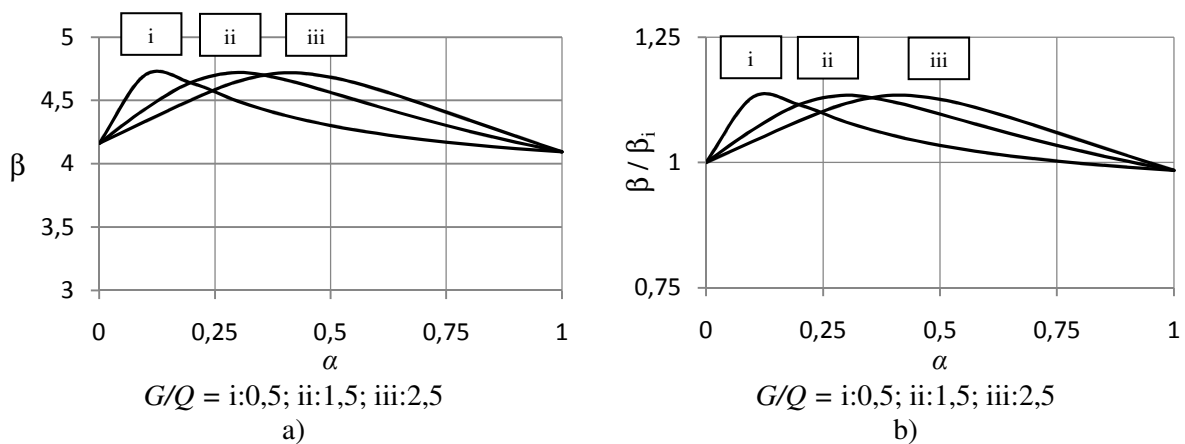

Figure 6.4: Reliability index regarding Eq. (6.11) of EC5 (CEN, 2004) for a single supported beam and different intensity relations between loads: a) reliability values; b) relation between  $\beta$  for  $\alpha = 0$  and  $\beta_i$  for  $\alpha = i$ , with  $i = [0,1]$

From Figure 6.4. it is noticeable that for higher relations between the expected values of permanent and live load, the maximum reliability is horizontally shifted to higher values of  $\alpha$ . In terms of value, the maximum reliability is approximately the same for all considered cases. However the different average reliability levels are approximate for the considered load combinations. Also, those values are always above the recommended for design, and therefore may be considered conservative. As expected, all different load scenarios reach equal values for  $\alpha = 0$  and  $\alpha = 1$ .

Regarding the design parameter, in this case the height ( $h$ ) of the cross-section, a comparison was made between the two methods for  $k_{mod}$  consideration. This analysis, also contemplated the different relations between the expected values of permanent and live load. The results are presented in Figure 6.5, where it is visible that the consideration of a linear variation of the  $k_{mod}$  factor always produces



higher values of height (bigger cross-sections) in the design process, thus, being a more conservative approach. The different relations between the expected values of permanent and live load lead to different evolutions of the design resistance parameter. When the value of live load is more significant this leads to an increment in the height of the cross-section for higher values of  $\alpha$  for both methods of  $k_{mod}$  consideration. On the other hand, when the live load is less influent in comparison with permanent load, the height of the cross-section decreases as  $\alpha$  increases. The bigger cross-sections were found for  $G/Q = 0.5$  and higher values of  $\alpha$ .

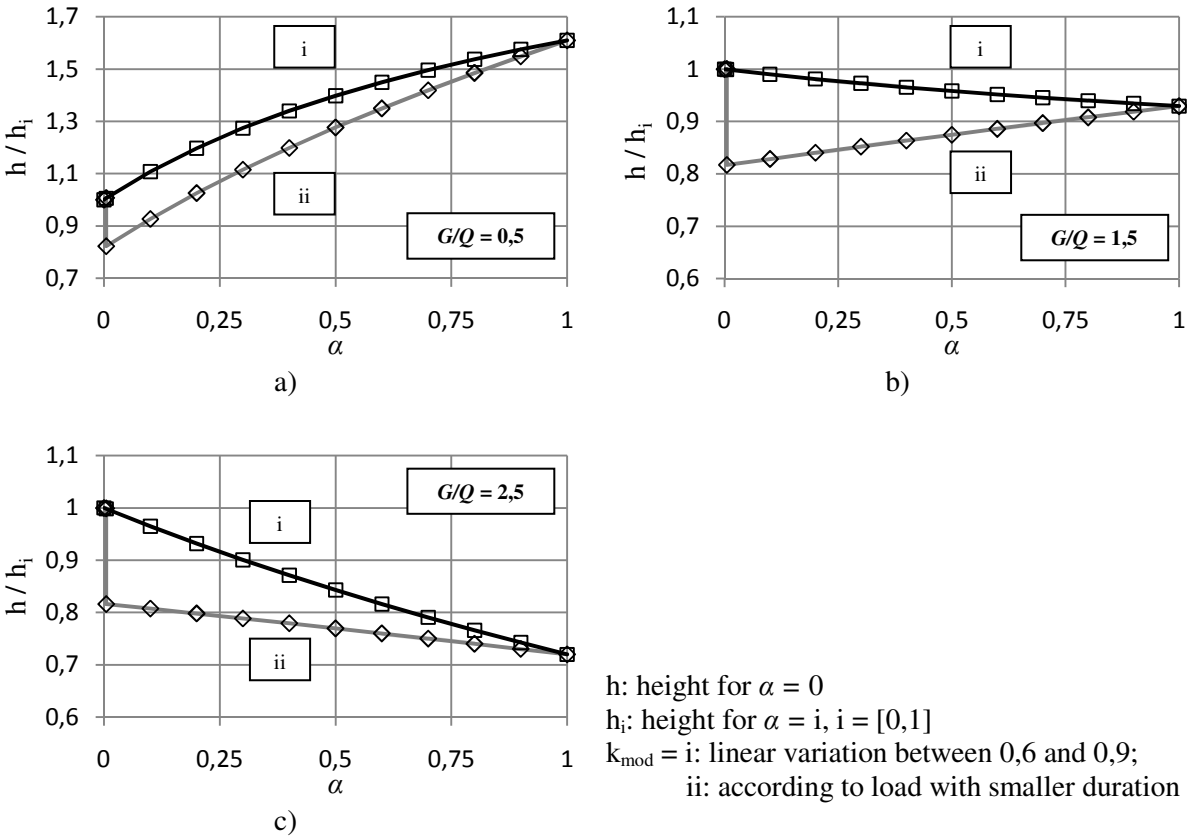

Figure 6.5: Evolution of the design resistant parameter, height of cross-section, for different relations between the expected values of permanent and live load

### 6.2.2 Sensitivity analysis

Since rehabilitation and renovation of buildings is an increasing market in the construction area, structural civil engineers are often required to determine the reliability of an existing structure in order to assess if that structure may be used for a different purpose. Therefore, a sensitivity analysis to different parameters is addressed in this section. The difference between this analysis and the analysis in section 6.2.1 resides in the consideration of a specific cross-section because the element already exists and it is not in a design stage. On the other hand, when the properties of a structure are known a better definition of the resistant values may be available (e.g. by use of NDT and MDT tests in timber structures) and therefore the uncertainty of those parameters may be decreased.

Attention must be paid to the point that the following procedure does not intend to indicate values for design, or even for assessment of designing codes, but to present a parameter sensitivity analysis to a specific existing timber element.

The variables considered in the stochastic model are presented in Table 6.2, and the resulting reliability evolution regarding  $\alpha$  factor is shown in Figure 6.6. A linear variation of  $k_{mod}$  between 0.6 and 0.9, respectively to  $\alpha = 0$  and  $\alpha = 1$  was used in this analysis. The ultimate state equation

considered consists in the simple bending verification, as given in Eq. (6.11) of Eurocode 5 (CEN, 2004)

Table 6.2: Variables used in the stochastic model

Variable	Distribution	E [X]	COV[X]	Comment
$f_m$	Lognormal	25 N/mm <sup>2</sup>	0.25	Bending strength
$G$	Normal	6 N/mm	0.10	Permanent load
$Q$	Gumbel	4 N/mm	0.40	Live load
$h$	Deterministic	400 mm	-	Height of the cross-section
$b$	Deterministic	200 mm	-	Width of the cross-section
$l$	Deterministic	6000 mm	-	Length of the beam

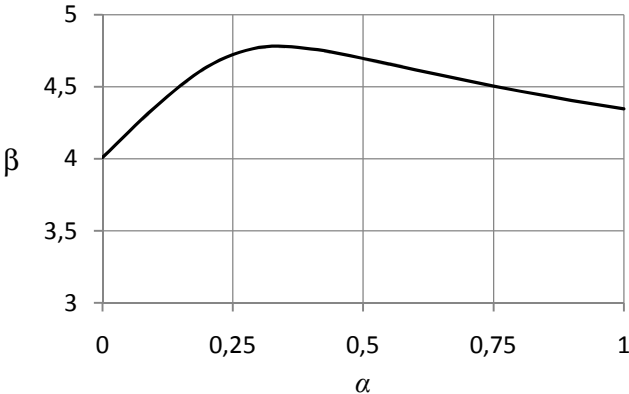

Figure 6.6: Reliability index with reference time one year regarding Eq. (6.11) of EC5 (CEN, 2004) for a specific existing single supported beam (stochastic models in Table 6.2)

Regarding different use scenarios for a building an analysis was conducted with respect to different expected values for live load but keeping the same expected value for permanent load. The results are presented in Figure 6.7 in two different measures. The first graph (Figure 6.7a) corresponds to the discrete values of the reliability index, whereas the second graph (Figure 6.7b) presents the same information but with a relation between  $\beta$  for  $\alpha = 0$  and  $\beta_i$  for  $\alpha = i$  ( $i = [0;1]$ ). The following figures have a similar procedure to present the results.

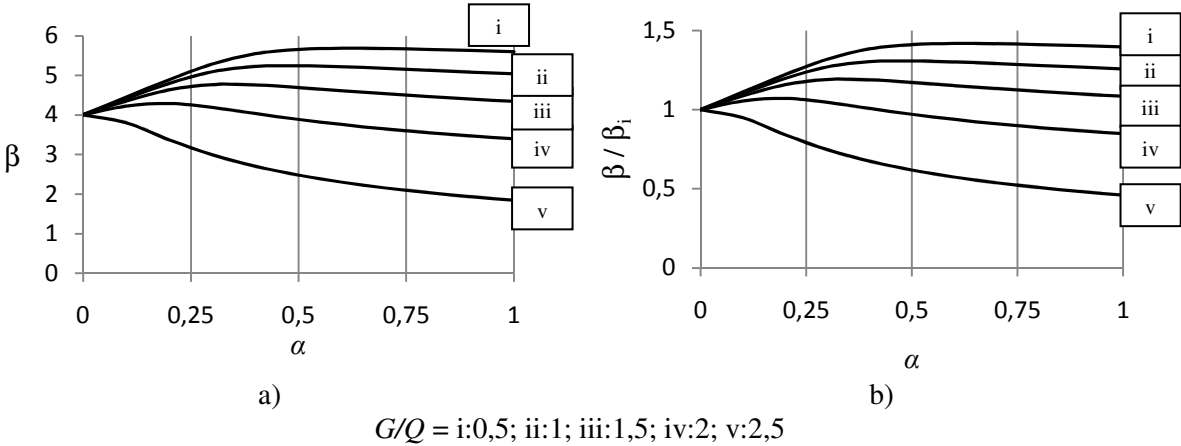

Figure 6.7: Reliability values for sensitivity analysis of  $G/Q$  factor

In respect to the considered stochastic variables, it is observed by Figure 6.7 that as the importance of live loads increases the reliability level decreases, especially for higher values of  $\alpha$ . The case of  $G/Q = 2.5$  is actually unsafe in terms of reliability indices for values of  $\alpha \geq 0.25$ . For the other cases, a

maximum value for reliability is observed near  $\alpha = 0.35$  and then reliability index decreases. Also in the case  $G/Q = 2$ , the reliability indices for  $\alpha = 0$  and  $\alpha = 1$  are similar.

A sensitivity analysis was also considered to the loads' coefficient of variation and the results are plotted in Figures 6.8 and 6.9, respectively for permanent and live load.

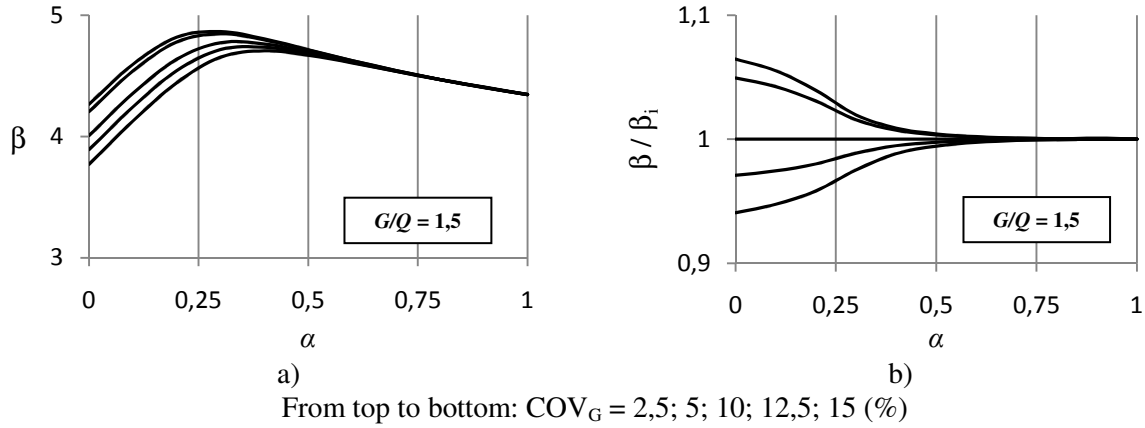

Figure 6.8: Reliability values for sensitivity analysis of  $COV_G$

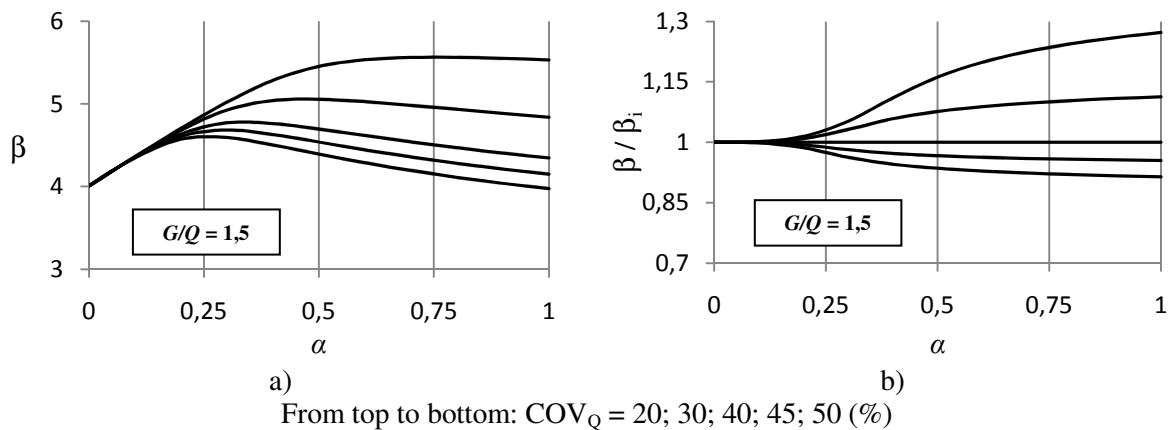

Figure 6.9: Reliability values for sensitivity analysis of  $COV_Q$

From the previous figures it is clear that the variation of  $COV_G$  is more important for lower values of  $\alpha$ , and the variation of  $COV_Q$  is more important for higher values of  $\alpha$ . This is a direct consequence of the definition of  $\alpha$ , such as when this factor increases the importance of variable load in respect to permanent load is increased. In this specific case, the influence of different  $COV_G$  begins to be neglected for  $\alpha \geq 0.55$ , whereas the influence of different  $COV_Q$  is small for  $\alpha \leq 0.15$ .

Nevertheless, a more relevant conclusion given by this analysis is that when the coefficient of variation for load parameters is increased the reliability of a given structure decreases, mainly due to the fact that the uncertainty of the problem is also increased.

The same procedure was considered regarding the coefficient of variation for the bending strength,  $COV_{f_m}$ . In this analysis it is shown that for all values of  $\alpha$ , different values of reliability are obtained, however, the higher differences are found for lower values of  $\alpha$ . The results are presented in Figure 6.10.

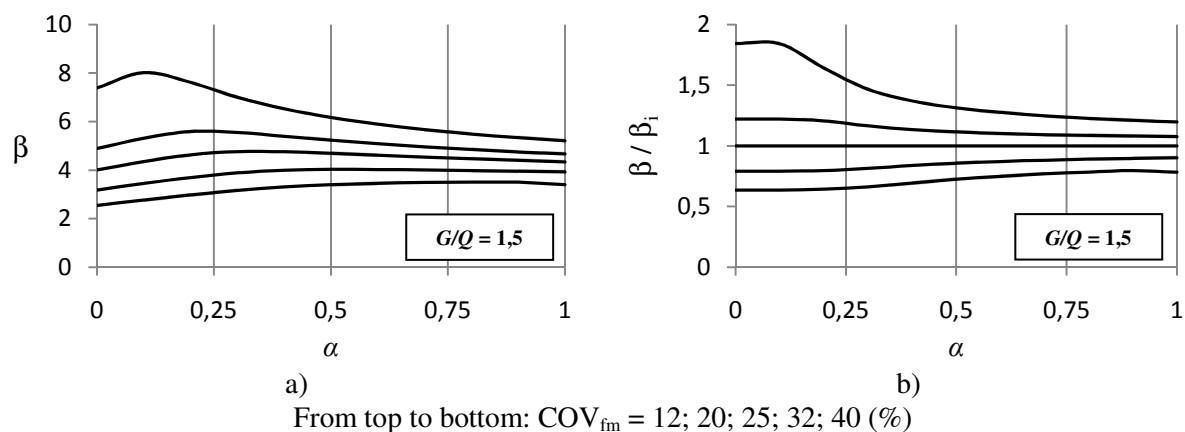

Figure 6.10: Reliability values for sensitivity analysis of  $COV_{fm}$

### 6.2.3 Structural life-cycle assessment

Timber is a natural material and many times its mechanical behaviour is influenced by deterioration processes. Decay in timber may be derived from many reasons. For each specific case, timber resistance to pathological agents (i.e. timber durability class) and environmental conditions (e.g. humidity, temperature, solar exposure) take important roles in the structural behaviour of those timber elements.

In this example an idealized decay model with two parameters was used with an initial propagation period of the deterioration phenomenon,  $t_{lag}$  (year) and an annual penetration ratio,  $r$  (mm/year) as described previously in Chapter 2. The deterioration process is considered to be due fungi attack. The limit state equation considered is the same of Eq. (6.2).

The variables considered in the stochastic model are presented in Table 6.3. Different ways to define the deterioration parameters were used in order to analyse the importance of their variation in the model's results. For all models, the  $\alpha$  factor was considered equal to 0.5.

Table 6.3: Variables used in the stochastic model

Variable	Distribution	E [X]	COV[X]	Comment
$f_m$	Lognormal	25 N/mm <sup>2</sup>	0.25	Bending strength
$G$	Normal	6 N/mm	0.10	Permanent load
$Q$	Gumbel	4 N/mm	0.40	Live load
$h$	Deterministic	400 mm	-	Height of the cross-section
$b$	Deterministic	200 mm	-	Width of the cross-section
$l$	Deterministic	6000 mm	-	Length of the beam
$r$	Deterministic	1 mm/year	-	Annual penetration ratio
	Lognormal	1 mm/year	0.50	Annual penetration ratio
	-	$r = k_{wood} \cdot k_{climate}$	-	Annual penetration ratio
$k_{wood}$	Lognormal	Table 6.4		Parameter of timber durability class
$k_{climate}$	Lognormal	Table 6.5		Parameter of climate conditions
$t_{lag}$	Deterministic	$t_{lag} = 3 r^{-0.4}$	-	Initial propagation period

Regarding different durability classes of timber and climatic zones, values for  $k_{wood}$  and  $k_{climatic}$  are presented in Tables 6.4 and 6.5.

Table 6.4: Values of  $k_{wood}$  for outer heartwood, adapted from Wang et al [2008]

Durability class	$k_{wood}$	$COV_{wood}$
1	0.165	0.45
2	0.38	0.55
3	0.65	0.75
4	1.40	0.90

Table 6.5: Values of  $k_{climate}$ , adapted from Wang et al [2008]

Zone*	$k_{climate}$	$COV_{climate}$
A	0.5	0.55
B	1.5	0.55
C	2.5	0.55
D	3.0	0.55

\*Zones defined for Australian territory, where zone D is the most hazardous

As first approach, the values used in Brites et al [2008] were considered. In that work, a timber truss was assessed with respect to the limit state equations given in EC5 (CEN, 2004). However, for this first analysis both the parameters of the deterioration model were defined as deterministic. The results are shown in Figure 6.11 regarding both reliability index and probability of failure for lifetime reference period of the structure.

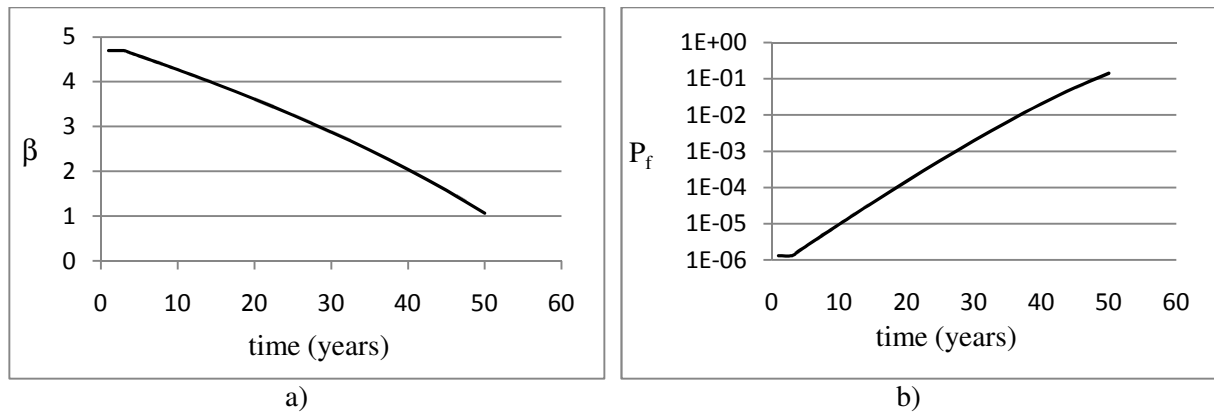

Figure 6.11: Time evolution deterioration curves for a bi-parametrical deterministic deterioration model: a) reliability indices; b) probability of failure

The bi-parametrical deterministic deterioration model resulted in a rather linear decrease in the reliability indices along time. The decrease in reliability is rather fast and the structure is deemed to require rehabilitation or strengthening works after 27 years if a limit of  $P_f = 10^{-3}$  is considered.

However, the evolution of this type of deterioration normally produces an exponential increment in the probability of failure when the fungi attack increases in time. To better describe this phenomenon, and also taking into account the work conducted in Brites et al [2008], a stochastic deterioration model was used. For that purpose the penetration ratio,  $r$ , was considered to have a Lognormal distribution with  $COV = 0.5$ . The parameter  $t_{lag}$  was considered to be deterministic and equal to 3 years.

The results of the stochastic model are shown in Figure 6.12 regarding both reliability index and probability of failure for lifetime reference period of the structure. This model presents a more commonly observed progression of the probability of failure due to this type of deterioration

phenomenon. After the period of propagation,  $t_{lag}$ , there is a high increase of the probability of failure. The reason for that may be explained through the fact that, when the deterioration process begins a higher area of cross-section is affected since this kind of deterioration progresses from the exterior to the interior of the cross-section affecting its perimeter.

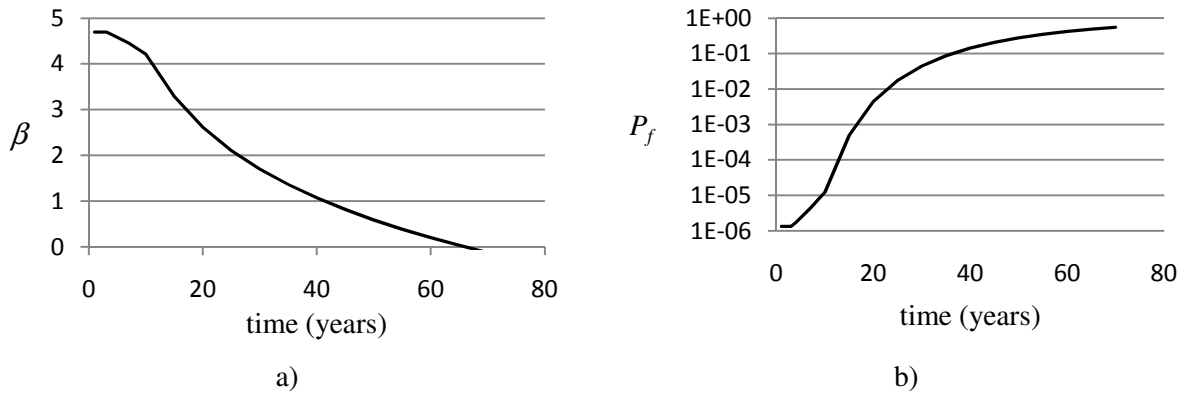

Figure 6.12: Time evolution deterioration curves for a stochastic deterioration model: a) reliability indices; b) probability of failure

Considering the same limit for probability of failure ( $P_f = 10^{-3}$ ), it is now defined that the structure would require an improvement in its structural performance around the age of 19 years.

A comparison between the previous considered models is presented in Figure 6.13 for both reliability index and probability of failure for lifetime reference period of the structure. For the beginning of the timber element lifetime it is noticed a similar behaviour for both models, however, after the first decade, it is observed that the stochastic model produces an exponential increase of the probability of failure giving, therefore, lower levels of reliability.

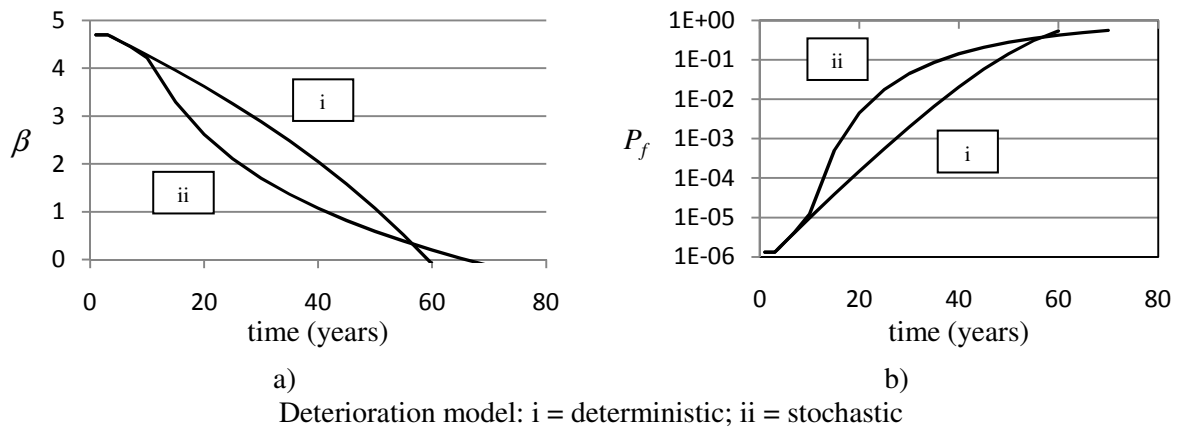

Figure 6.13: Comparison between models: a) reliability indices; b) probability of failure

The previous figures present the results considered for a lifetime reference period of time, however many design codes provide limits of reliability indices for one year reference period. The annual reliability index is given as:

$$\beta_{annual}(t) = -\Phi^{-1}(P_f(t) - P_f(t - 1)) \tag{6.4}$$

where  $P_f(t)$  is the probability of failure in  $[0,t]$ .

Regarding the previous considered stochastic model for decay, the annual reliability index was plotted for the period of time after the limit previously considered. This analysis intends to analyse how both reference periods of time (lifetime and one-year) evolve after the considered limit. The results are shown in Figure 6.14, where it is seen that for one year reference period a similar decrease is visible however, much smoother reaching almost a constant value around  $\beta_{annual} = 2.2$ .

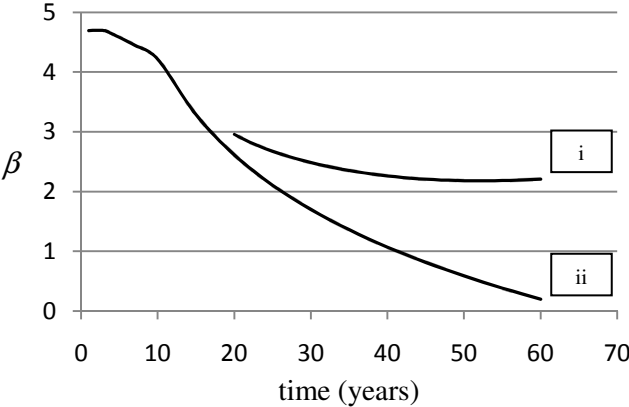
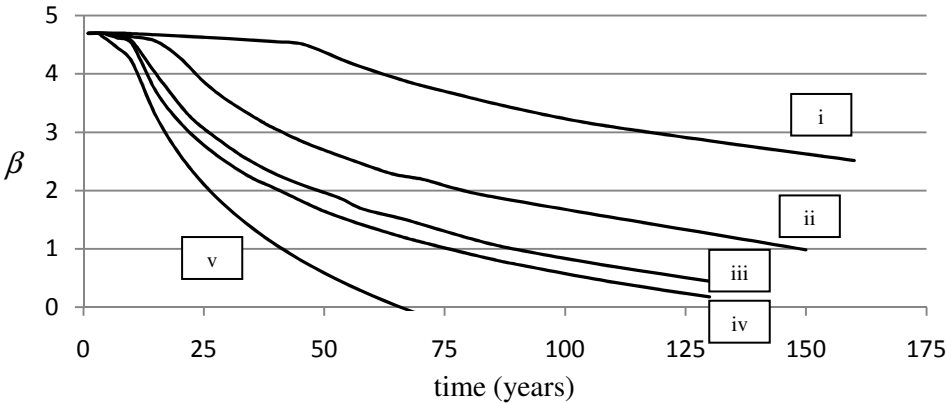

Figure 6.14: Time evolution deterioration curves for a stochastic deterioration model: i) one-year reference period; ii) lifetime reference period

For the following analysis and results, a lifetime reference period is considered.

As already mentioned, timber is highly dependant of the climatic conditions of the surrounding environment. Also the attack of pathological agents is more significant in a specific range of values for humidity, temperature and solar exposure. In Wang et al [2008] four different climate zones were considered for the Australian territory. In order to assess the differences that climatic factors may have in the reliability level of a structure, an analysis was conducted varying the climatic zones. The structural element is the same as the previous analysis but it was considered that it has a durability class 1 ( $k_{wood} = 0.165$ ). The results for the different deterioration curves regarding different climatic zones are presented in Figure 6.15, where the stochastic model presented in Brites et al [2008] is also plotted, for lifetime reference period of the structure.



Climatic zones: i = A; ii = B; iii = C; iv = D; and: v = model adapted from Brites et al [2008]

Figure 6.15: Comparison between deterioration models for different climatic zones

As expected, the reliability index decreases faster when the climatic conditions are more hazardous because the propagation of deterioration in the timber element is also faster. For low values of  $k_{climate}$

there is an initial period of time that produces almost no change in reliability. However, after that period of time the reliability starts to decrease in a similar way to the curves corresponding to higher values of  $k_{climate}$ .

When comparing the different models, it is visible that the most unsafe curve is given by the previous considered stochastic model with  $r = 1$  mm/year and  $COV = 0.5$ . The main reason is due to the fact that the mean value of penetration ration for the other models is inferior to 1 mm/year even regarding the combined uncertainties of the parameters  $k_{wood}$  and  $k_{climate}$ .

#### 6.2.4 Data updating

This section presents a possible example how NDT and MDT may be used in order to update the information that will be incorporated in a deterioration model for timber structures.

The deterioration model considered before may be upgraded regarding the parameter  $r$ . For that purpose, it is supposed that a trial of tests with a Resistograph device were done. As previously mentioned this kind of tests allows determining areas with different resistance to the drilling process, thus making it possible to see decayed areas and its depth. With these measurements the residual cross-section may be derived and therefore the model of deterioration may also be upgraded.

The hypothetical tests performed to the structure were conducted in the year 19. From these tests it is intended to assess the timber element reliability and to verify if the most hazardous model considered previously was accurate. Also from this, a updated model may be achieved and therefore a more suitable program of maintenance and rehabilitation works may be found for this specific scenario.

Consider that 8 tests were performed obtaining different values of residual cross-section. From those values a sample of penetration ratios were found as presented in Table 6.6. As seen previously, the  $r$  is often described by a lognormal distribution with coefficient of variation equal to 0.5. Regarding this fact two approaches were considered in order to update the deterioration model. These approaches regard vague *prior* information on the mean and on both mean and standard deviation for the updating scheme. As seen in Chapter 4, the lognormal stochastic variable  $X$  can be treated in a similar way as a normal distributed variable, for an updating scheme, since  $Y = \ln X$  is normal distributed.

Table 6.6: Sample of penetration ratios derived from hypothetical Resistograph tests

	$r$ (mm/year)								$\mu$	$\sigma$
$X_i$	0,45	0,52	0,65	0,47	0,40	0,42	0,55	0,54	0,50	0,076
$Y_i = \ln(X_i)$	-0,799	-0,654	-0,431	-0,755	-0,916	-0,868	-0,598	-0,616	-0,70	0,150

Considering vague information on both mean and standard deviation, a fifth quantile value for  $r$  was obtained with respect to the following equation:

$$X_d = \exp(m(Y)) \exp\left(t_{vd} s(Y) \sqrt{1 + \frac{1}{n}}\right) \quad (6.5)$$

That value and the standard deviation observed for the test results were them used to obtain the mean value of  $r$ , from the following equation:

$$x_{0,05} \approx \mu \exp\left(-1.645 \frac{\sigma}{\mu}\right) \quad (6.6)$$

where -1.645 is obtained from the standard Normal distribution function such that  $\Phi(-1.645) = 0.05$ , and  $x_{0,05}$  is the fifth quantile of the Lognormal variable.



A mean value for  $r$  of 0.57 mm/year and standard deviation of 0.16 mm/year was now calculated and implemented in the deterioration model. In respect to this, the upgraded model of deterioration of the timber element was considered from the date of the inspection and tests. In Figure 6.16, the updated model may be compared with the first previsions made with a previous model.

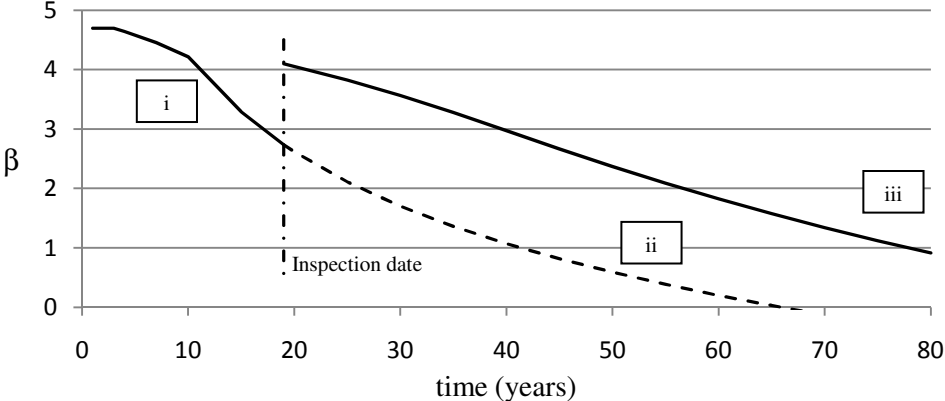

Decay model: i = assumed before information of NDT ( $r = 1$  mm/year;  $COV_r = 0.5$ ); ii = after information of NDT, but not upgraded ( $r = 1$  mm/year;  $COV_r = 0.5$ ); iii = upgraded model with NDT data ( $r = 0.57$  mm/year;  $\sigma_r = 0.16$  mm/year)

Figure 6.16: Deterioration models with updating

By upgrading the model with information from the NDT's an increase in reliability is well noticed. For the same limit of probability of failure ( $P_f = 10^{-3}$ ) the structure more than doubles its predicted lifetime. The differences, although significantly large may be explained by different reasons. The element may have not been exposed to extreme conditions of humidity or temperature or it might be from a higher durability class than first assumed.

It must be paid attention to the fact that the hypothetical results given by the NDT's may had also indicated a decrease in reliability, as it will be presented in a following example.

For the next approach, it was considered that the information from the coefficient of variation of  $r$  is known and equal to the model used previously ( $COV_r = 0.5$ ).

Using Eq. (6.7) for the predictive value of  $r$  and also using Eq. (6.6), a mean value of 0.58 mm/year and standard deviation of 0.35 mm/year was obtained and used in the updating of the deterioration model.

$$X_d = m - t_{n-1}s \sqrt{\left(1 + \frac{1}{n}\right)} \tag{6.7}$$

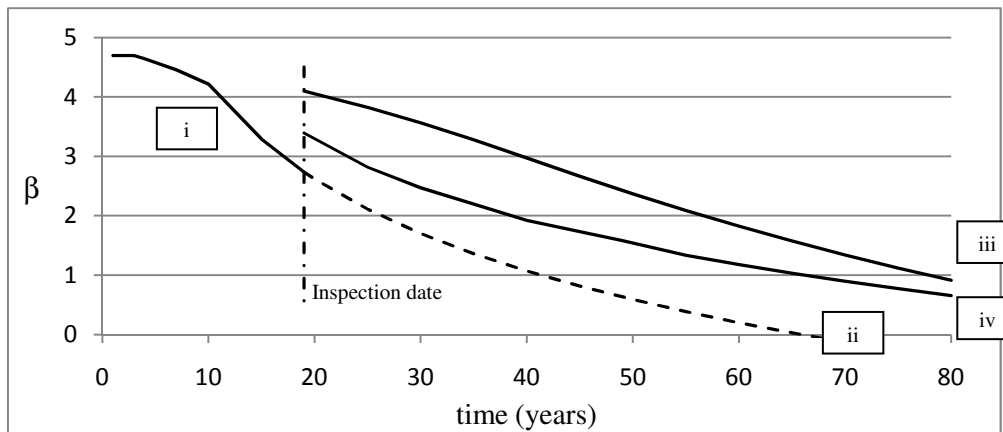

Decay model: i = assumed before information of NDT; ii = after information of NDT, but not upgraded; iii = upgraded model with NDT data, with no *prior* information; iv = upgraded model with NDT data with  $\sigma$  known

Figure 6.17: Deterioration models with updating

From Figure 6.17 it is shown that with the model updated with  $\sigma$  known, lower values of reliability are presented. It is consequence from the consideration of a coefficient of variation in *prior* information higher than the observed in the NDT's. From this two conclusions may be pointed:

- the *prior* information is not adequate to this specific structure and climate and, thus should be disregarded;
- or, the number of tests is insufficient and therefore the observation sample is not adequate and should be improved.

Now, let us consider that after 5 years upon the first inspection date, therefore at time equal to 24 years, the structure was exposed to different environmental conditions (e.g. due to water infiltrations, floods) allied to bad maintenance, which led to propitious conditions for fungi attack. Let, then also consider that a year after, this situation was noticed and dealt with and so the previously environmental conditions were restored.

To assess the damage made by these events another trial of tests were conducted. Although the results are of the same type that the previously made at time equal to 19 years they can not be implemented in the same way for an updating scheme. Since the idealized model considers that fungi attack produces a linear deterioration from the outside to the interior of the cross-section, events that produce a discontinuity in the environmental conditions do not fit in this model. Therefore, after assessing the possible decrease in reliability the evolution of deterioration must be considered for that level of reliability with the same trend given by the model before the hazardous event. This simplification may only be applied if the initial environmental conditions are restored.

Since the deterioration parameters may have been changed, due to the hazardous events, it is recommended for these situations that monitoring actions are considered in the subsequent years. A suitable monitoring plan will be, therefore, the strongest tool to assess the deterioration evolution for timber structures and also for management of maintenance and strengthening actions.

The following figure presents a schematic drawing of the possible influence of a hazardous event in the deterioration model (Figure 6.18). The deterioration model was considered to be the one given by the updating based in no *prior* information.

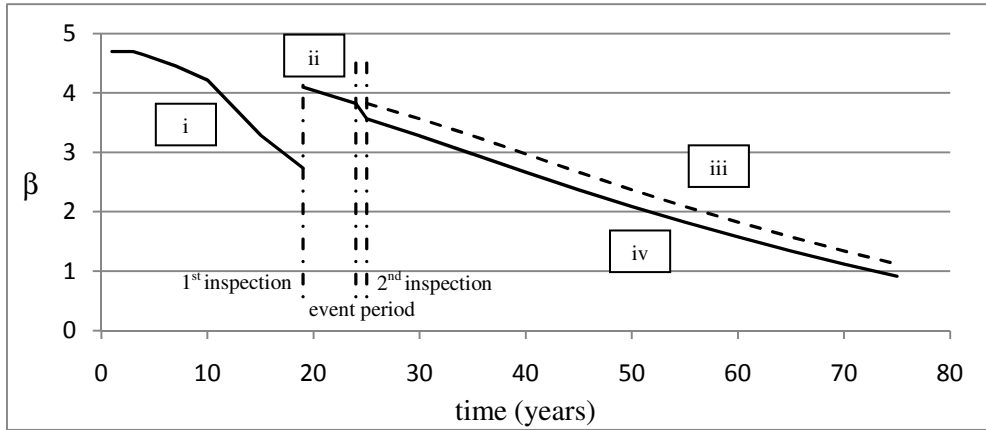

Decay model: i = assumed before information of NDT; ii = upgraded model with 1<sup>st</sup> NDT data before the event; iii = upgraded model with 1<sup>st</sup> NDT data after the event; iv = upgraded model with 1<sup>st</sup> NDT data and with 2<sup>nd</sup> NDT safety assessment information

Figure 6.18: Deterioration models with updating

### 6.2.5 Reliability-based robustness index

For the purpose of this example let us consider, once more, the deterioration model with  $r = 1\text{mm/year}$  and  $COV_r = 0.5$ . Since the deterioration phenomenon has a constant activity, also the reliability decreases in time and therefore robustness may also be considered to be decreased. Redundancy index and the redundancy factor are not suitable to be considered for this example since this is not a redundant structure.

Robustness may be considered as the ability of the system to suffer an amount of damage not disproportionate with respect to the causes of the damage itself [Biondini, 2008]. Therefore, deterioration must be defined in a period of time in order to assess if the effects in respect to this phenomenon are in proportion to the causes. Depending on the importance of a specific structure and regarding to structural and durability performance, different design lifetimes are considered. For instance, let us consider that this example structure was design to sustain a period of time of 50 years. Since degradation is a long duration cause of damage, a time index  $TI$  was considered as:

$$TI = \frac{T_{lim} - T_d}{T_d} \quad (6.8)$$

where  $T_{lim}$  is the time given by the deterioration model for a defined limit of reliability, and  $T_d$  the time lifetime used for design. The values of  $TI$  may be equal:

- to -1 if the structure has a lower reliability than the required at time = 0, however this value must be disregarded for the case of deterioration causes. This value can only be obtained if a wrong design procedure was taken;
- to ]-1;0[ if the reliability limit time is obtained before the design time;
- to 0 if the reliability limit time is obtained exactly at the design time;
- to > 0 if the reliability limit time occurs after the design time, which is normally the required condition for safety conditions.

For this case, if a limit reliability level of  $P_f = 10^{-3}$  is considered than a  $TI_{50} = -0.62$  is obtained and therefore presenting that the damage due to the deterioration process limits the performance and life expectancy of the structure.

Reliability-based robustness indices may be obtained in a similar way regarding the updating of deterioration models with NDT data. If the previously hypothetical data would be considered than, for

the case of the model updated with no *prior* information, a  $TI_{50} = -0.22$  would be obtained. Although this index presents an indication of a higher robustness, it is erroneous to conclude that upgrading a model leads to a better or worse level of robustness. Actually, updating a model will only provide a more accurate and precise definition of the structural behaviour of a specific element or system of elements, both in terms of reliability and robustness.

### 6.3 EXAMPLE CASE B: COLUMN

The second example consists in a column exposed to different load combinations of permanent and live load. The loads are considered as concentrated loads applied at the top of the column. Therefore, the column transmits, through compression, the effects of loading to the support elements at the bottom of the column. The combination of loads is modelled as given in Eq. (6.1).

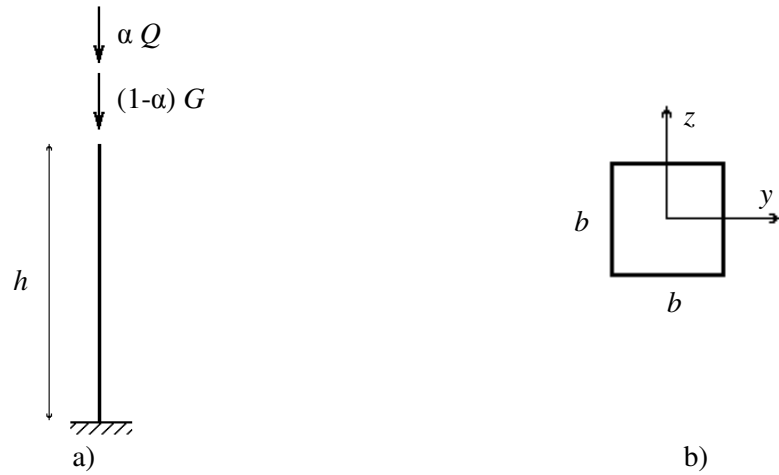

Figure 6.20: Column: a) structural model; b) cross-section

The beam is made of solid timber and considered to have a square cross-section.

#### 6.3.1 Design by Eurocodes

For reliability assessment of this structure the fundamental combinations given by Eq. (6.10) of Eurocode 0 (CEN, 2002a) was assumed. Therefore, the characteristic values for resistance and load parameters were considered for the limit state equation. These values are also influenced by partial safety factors.

The limit state equation was considered to be related to the maximum compression stress along the height of the column. The following limit state equation was used:

$$g = k_{mod} f_{c,0} - ((1 - \alpha)G + \alpha Q)/A \quad (6.9)$$

and  $z$  is the design parameter assumed from the corresponding design equation and for this case considered to be the area,  $A$ , of the cross-section.  $A$  is chosen as design parameter and is obtained from:

$$k_{mod} \frac{f_{c,0,k}}{\gamma_m} - ((1 - \alpha)G_k \gamma_G + \alpha Q \gamma_Q)/A \geq 0 \quad (6.10)$$

The  $k_{mod}$  parameter was considered as suggested by Eurocode 5 (CEN, 2004) where  $k_{mod}$  is primarily dependant of the action with smaller duration.

The reliability obtained with consideration to design of timber elements subjected to simple compression, as given in Eq. (6.2) of Eurocode 5 (CEN, 2004), is presented in Figure 6.21. The variables were defined as according to previously mentioned stochastic models and the values that were considered are presented in Table 6.7. For this analysis it was considered that the height,  $h$ , of the column would be such that second order effects on structures (e.g. buckling of slender elements) could be disregarded.

Table 6.7: Variables used in the stochastic model

Variable	Distribution	E [X]	COV[X]	Comment	Characteristic value
$f_{c,0}$	Lognormal	21.3 N/mm <sup>2</sup>	0.2	Compression strength // grain	5%
$G$	Normal	60 000 N	0.10	Permanent load	95%
$Q$	Gumbel	40 000 N	0.40	Annual maximum live load	98%
$A$	Deterministic	design parameter	-	Area of the cross-section	-
$\gamma_m$	Deterministic	1.3	-	Partial safety factor	-
$\gamma_G$	Deterministic	1.35	-	Partial safety factor	-
$\gamma_Q$	Deterministic	1.5	-	Partial safety factor	-

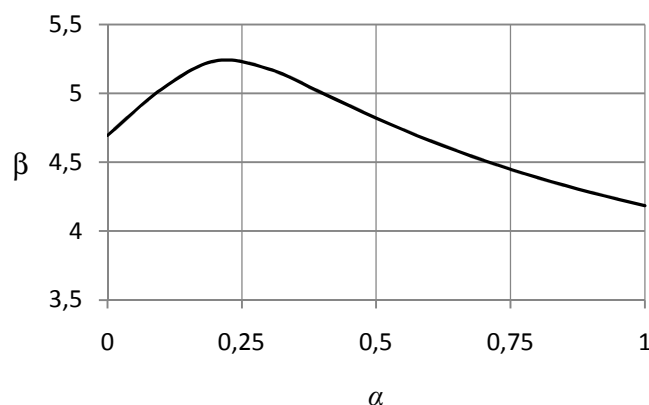

Figure 6.21: Reliability index with reference time one year regarding Eq. (6.2) of EC5 (CEN, 2004) for a column subjected to different load combinations (stochastic models in Table 6.7)

The obtained reliability level was always above  $\beta = 4$ , reaching values higher than  $\beta = 5.2$  around  $\alpha = 0.2$ . The mean value found for reliability was approximately  $\beta = 4.7$  which is higher than the suggested in the PMC [JCSS, 2000] for 1 year reference period and reliability class 1. Also, it is noticeable that this limit function equation for simple compression produces similar design reliabilities compared to the simple bending limit equation in terms of evolution with  $\alpha$  (Figures 6.21 and 6.3). However, the reliability values obtained according to the limit states equations as suggested by EC5 [CEN, 2004] for design in simple compression are higher than for simple bending. Another difference is that, in this case,  $\beta$  for  $\alpha = 1$  is inferior than  $\beta$  for  $\alpha = 0$ .

### 6.3.2 Data updating

In Feio [2005] correlations between NDT results and values of compression strength parallel to the grain are obtained for chestnut tree elements. With respect to that data an uncertainty analysis was conducted through a maximum likelihood method. The objective of this analysis is to have a suitable method to upgrade the value of compressive strength parallel to grain of a timber element when NDT

results are available and also to consider the uncertainty involved in this process. For that purpose a Maximum Likelihood method was applied.

### **Maximum Likelihood method**

The Maximum Likelihood method can, for example, be used to fit the statistical parameters in distribution functions and to fit the parameters in linear and non-linear regression analysis [Sørensen, 2003]. Also when considering a sample of results taken from tests a linear regression may be estimated including a uncertainty parameter or also called lack-of-fit parameter.

For parameter estimation for linear regression lines, the following linear regression model in  $x_1, \dots, x_m$ -space is considered:

$$y = \alpha_0 + \alpha_1 x_1 + \dots + \alpha_m x_m + \varepsilon \quad (6.11)$$

where  $\alpha_0, \alpha_1, \dots, \alpha_m$  are the regression parameters and  $\varepsilon$  models the lack-of-fit.  $\varepsilon$  is assumed to be Normal distributed with expected value 0 and standard deviation  $\sigma_\varepsilon$ .

It is assumed that  $n$  sets of observations or test results of  $(x, y)$  are available and denoted as:  $(x_1, y_1), \dots, (x_n, y_n)$ . The regression parameters are determined using a Maximum Likelihood method. The Likelihood function is written with  $x_{ij}$  being the  $j$ th coordinate of the  $i$ th observation:

$$L(\alpha_0, \alpha_1, \dots, \alpha_m) = \prod_{i=1}^n P(y_i = \alpha_0 + \alpha_1 x_{i1} + \dots + \alpha_m x_{im} + \varepsilon) \quad (6.12)$$

or, as in this case if it is used that  $\varepsilon$  is Normal distributed and  $\sigma_\varepsilon$  is included as a parameter to be estimated, then it follows:

$$L(\alpha_0, \alpha_1, \dots, \alpha_m, \sigma_\varepsilon) = \prod_{i=1}^n \frac{1}{\sqrt{2\pi\sigma_\varepsilon}} \exp\left(-\frac{1}{2} \left(\frac{y_i - (\alpha_0 + \alpha_1 x_{i1} + \dots + \alpha_m x_{im})}{\sigma_\varepsilon}\right)^2\right) \quad (6.13)$$

The Log-Likelihood function becomes:

$$\ln L(\alpha_0, \alpha_1, \dots, \alpha_m, \sigma_\varepsilon) = -n \ln(\sqrt{2\pi\sigma_\varepsilon}) - \sum_{i=1}^n \frac{1}{2} \left(\frac{y_i - (\alpha_0 + \alpha_1 x_{i1} + \dots + \alpha_m x_{im})}{\sigma_\varepsilon}\right)^2 \quad (6.14)$$

The optimal parameters are determined from the optimization problem:

$$\max_{\alpha_0, \alpha_1, \dots, \alpha_m, \sigma_\varepsilon} \ln L(\alpha_0, \alpha_1, \dots, \alpha_m, \sigma_\varepsilon) \quad (6.15)$$

### **NDT and MDT data**

In Feio [2005], correlations were obtained between values of compression strength parallel to the grain with results from tests with Resistograph, Pilodyn and Ultrasounds devices. The correlations that were found are presented in Figure 6.22. The data, from which these correlations are derived, is given in Annex C.

Firstly, the parameters that each NDT and MDT test gave must be described. The resistographic measure represents the ratio between the integral of the area of the diagram and the height of the test specimens, which is therefore an average value. This value is given as:

$$RM = \frac{\int_0^h Area}{h} \quad (6.16)$$

For the case of the Pilodyn, the considered measure parameter is the needle penetration depth taken directly from the tests.

In the case of the Ultrasonic pulse velocity method the (elasto)dynamic modulus of elasticity,  $E_{din}$ , was calculated by:

$$E_{din} = V^2 \rho \quad (6.17)$$

where  $E_{din}$  represents the (elasto)dynamic modulus of elasticity ( $N/mm^2$ ),  $V$  is the propagation velocity of the longitudinal stress waves (m/s) and  $\rho$  is the density of the specimens ( $kg/m^3$ ). It must be noted that the indirect method was used in the ultrasonic tests.

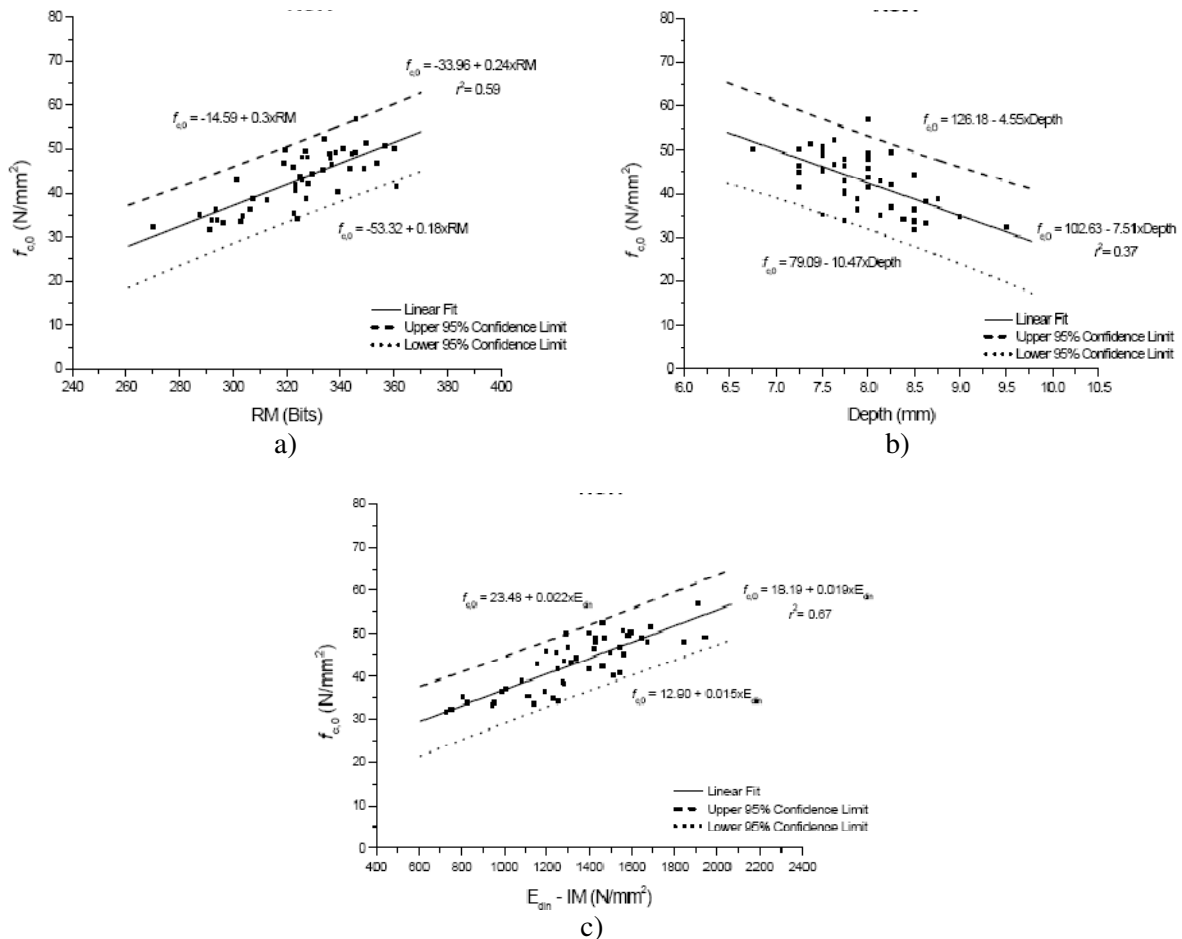

Figure 6.22: Relations for new chestnut tree timber between  $f_{c,0}$  and: a)  $RM$  (Resistograph); b) pin depth (Pilodyn); c)  $E_{din}$  (Ultrasounds), adapted from Feio [2005]

According to a Maximum Likelihood method, such as the one described previously, the results show that the best fit linear regression may be given as:

$$y = a - bx \quad (6.18)$$

And the uncertainty is included with consideration of the parameter  $\varepsilon$ , Normal distributed with expected value equal to 0, as:

$$y = a - bx + \varepsilon \quad (6.19)$$

Using the Maximum Likelihood method, the Resistograph tests' data results in the following optimal estimates:

$$a = -50.17227 \quad b = -0.35657 \quad \sigma_{\varepsilon} = 4.07426$$

The standard deviations on the estimates are obtained to:

$$\sigma_a = 10.72745 \quad \sigma_b = 0.03903 \quad \sigma_{\sigma_{\varepsilon}} = 0.42477$$

with corresponding coefficients of variation:

$$\text{COV}_a = -0.21381 \quad \text{COV}_b = -0.10946 \quad \text{COV}_{\sigma_{\varepsilon}} = 0.10426$$

The correlation coefficient matrix for the estimates becomes:

$$\rho = \begin{bmatrix} 1 & 0.99843 & -0.00553 \\ 0.99843 & 1 & -0.00555 \\ -0.00553 & -0.00555 & 1 \end{bmatrix}$$

Using the same process for the Pilodyn tests' data it results in the following optimal estimates:

$$a = 102.59179 \quad b = 7.50664 \quad \sigma_{\varepsilon} = 5.12435$$

The standard deviations on the estimates are obtained to:

$$\sigma_a = 11.44664 \quad \sigma_b = 1.43733 \quad \sigma_{\sigma_{\varepsilon}} = 0.52853$$

with corresponding coefficients of variation:

$$\text{COV}_a = 0.11157 \quad \text{COV}_b = 0.19147 \quad \text{COV}_{\sigma_{\varepsilon}} = 0.10314$$

The correlation coefficient matrix for the estimates becomes:

$$\rho = \begin{bmatrix} 1 & 0.99787 & 0.00326 \\ 0.99787 & 1 & 0.00324 \\ 0.00326 & 0.00324 & 1 \end{bmatrix}$$

Finally, considering the Ultrasonic tests' data it results in the following optimal estimates:

$$a = 19.24686 \quad b = -0.01761 \quad \sigma_{\varepsilon} = 4.06081$$

The standard deviations on the estimates are obtained to:

$$\sigma_a = 2.86605 \quad \sigma_b = 0.00208 \quad \sigma_{\sigma_{\varepsilon}} = 0.41868$$

with corresponding coefficients of variation:

$$\text{COV}_a = 0.14891 \quad \text{COV}_b = -0.11837 \quad \text{COV}_{\sigma_{\varepsilon}} = 0.10310$$



The correlation coefficient matrix for the estimates becomes:

$$\rho = \begin{bmatrix} 1 & 0.97841 & -0.00132 \\ 0.97841 & 1 & -0.00137 \\ -0.00132 & -0.00137 & 1 \end{bmatrix}$$

### Reliability assessment

In order to evaluate the validity of the considered correlations and of each linear regression a reliability analysis was conducted. Also with this procedure it is intended to analyse the influence of the uncertainty introduced by each separate NDT or MDT. Firstly, the resistant parameters of the column were implemented in reference stochastic models considering the values for compression strength parallel to the grain given by the destructive tests. Then for an updating scheme, the compression strength parallel to the grain was modelled with respect to the linear regression obtained by the maximum likelihood method for each NDT or MDT. The parameters of the models are given in Table 6.8.

Table 6.8: Variables used in the stochastic model

Variable	Distribution	E [X]	COV[X]	Comment
$f_{c,0}$	Lognormal	$\mu_{\text{destructive tests}}$	0.2	Compression strength // grain – mean value of destructive tests
$f_{c,0}$	Lognormal	$\mu_{\text{destructive tests}}$	$\sigma_{\text{destructive tests}} = 0.15$	Compression strength // grain – mean value and COV of destructive tests
$f_{c,0}$	-	$a - b \mu_{\text{RM}} + \varepsilon$	-	Compression strength // grain – mean value of Resistograph tests
$f_{c,0}$	-	$a - b \mu_{\text{depth}} + \varepsilon$	-	Compression strength // grain – mean value of Pilodyn tests
$f_{c,0}$	-	$a - b \mu_{\text{Edin}} + \varepsilon$	-	Compression strength // grain – mean value of Ultrasound tests
$\varepsilon$	Normal	0	$\sigma_{\varepsilon}$	Uncertainty parameter of each NDT or MDT
$G$	Normal	60 000 N	0.10	Permanent load
$Q$	Gumbel	40 000 N	0.40	Annual maximum live load
$A$	Deterministic	$60 \times 60 = 3600 \text{ mm}^2$	-	Area of the cross-section

The two reference models for  $f_{c,0}$  pretend to establish a benchmark for comparison. The first one is modelled by the mean value of the destructive tests and with a coefficient of variation as proposed by Table 2.1 [JCSS, 2006]. The second is modelled by the mean value and COV as given by the destructive tests. For both models, a Lognormal distribution was considered.

According to the NDT and MDT data, three models were made with respect to each type of test. The results for the reference models and for the models upgraded by the correlations between compression strength parallel to grain and results from NDT and MDT are given in Figure 6.23. The  $k_{mod}$  parameter was considered as suggested by Eurocode 5 (CEN, 2004) where  $k_{mod}$  is primarily dependant of the action with smaller duration.

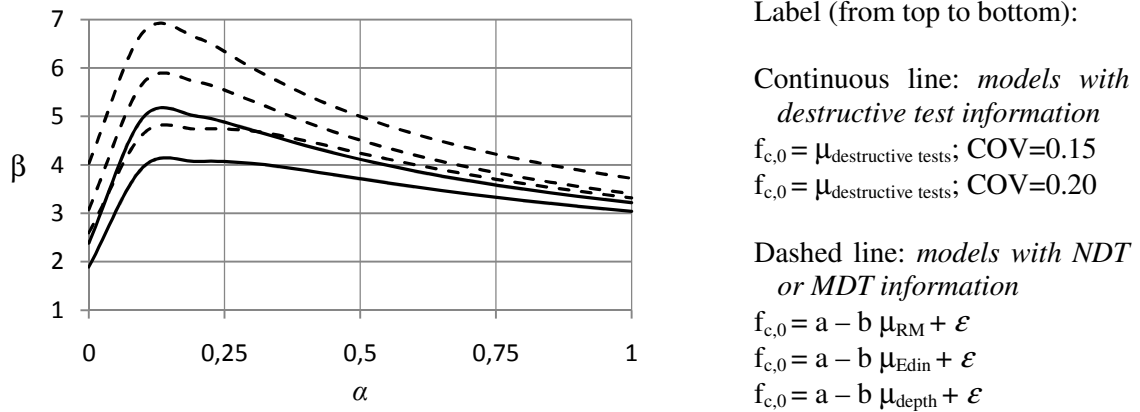

Figure 6.23: Reliability of the reference models and models obtained by NDT and MDT information

The results shown in Figure 6.23 denote higher values of reliability for the models updated with NDT or MDT data. This is mainly due to the consideration of  $f_{c,0}$  as a function of the correlation given between the destructive and non-destructive tests. Although uncertainty is implemented through the consideration of the parameter  $\varepsilon$ , some variability of  $f_{c,0}$  is lost since it was already considered in the reference models as a stochastic variable.

The Resistograph and Ultrasound updating scheme must be used with attention since they led to higher values of reliability than the references values. The main differences are found for the maximum value of the reliability curves around  $\alpha = 0.12$ . However, the data with respect to the Pilodyn tests presented very similar values to one of the reference models ( $f_{c,0} = \mu_{\text{destructive tests}}; \text{COV}=0.15$ ).

## 7. CONCLUSIONS

The objective of this STSM was to address reliability methods for analysis of timber structures using information gathered through NDT or MDT results in an upgrading scheme. With respect to that, different methodological procedures were mentioned for implementation of test results into a resistance model of timber structures.

The first part of this work consists in a description of the current knowledge with importance to reliability analysis of structures, methodologies for safety assessment and characterization of timber structures. For that purpose, a brief introduction to timber characteristics as a natural and construction material was made. Stochastic models regarding resistance parameters, spatial variability, size effect and failure types were mentioned, as well as common used NDT and MDT for timber structures.

Further on, a theoretical background for structural reliability assessment including probabilistic concepts for structural systems and stochastic models were given. System models, both series and parallel systems, were presented as well as methods for reliability calculation. The importance and influence of ductility in systems was mentioned.

Regarding the updating of data, Bayesian methods were described and a sensitivity analysis was conducted to study the importance of different parameters introduced in *prior*, *posterior* and predictive distributions. From that analysis it was concluded that the number of test samples may reach a value from which further tests will not result in a considerable gain of information. Also it was concluded that Bayesian statistic allows incorporating the engineer judgement and experience (cases of *prior* information or vague information) into the stochastic model, thus resulting that different reassessment engineers may produce different results. Therefore it is recommended that further investigation is made in order to define and reach a consensus for such analyses, thus leading to a common and consistent framework where different results may be compared adequately.

A framework for robustness was also taken into account in this work. Also usual methods to assess robustness were mentioned. However the most important conclusion regarding robustness is that further work must be considered to establish a common basis of assessment of structures. However, regarding similar but different definitions of robustness it is concluded that a robustness index is highly dependant of the structure itself and of the actions to which it is exposed. Therefore establishing comparisons between different structures or to the same structure but exposed to different types of actions may prove difficult.

The second part of this work presented two practical examples where the information and knowledge gathered before were implemented. Design limit function equations were considered and analysed in terms of reliability for different load combinations. Lifecycle deterioration models were also analysed with respect to possible upgrading methods and after considerations to the reliability level were made.

From a sensitivity analysis, it was found that different variations in load and resistant models will produce different levels of reliability, and thus being necessary to correctly evaluate the present conditions of a given structure when dealing with safety assessment. Attending to the considered idealized decay model it was, also, concluded that the environmental climate conditions and durability classes of timber are extremely important parameters to predict and assess the lifecycle performance and durability of a timber structure. Regarding the objective of this work, upgrading of the decay model was made with consideration to hypothetical NDT results and concluded that the implementation of new data trough this procedure can result in having better maintenance / strengthening planning. By having a better knowledge of the deterioration process, a more accurate assessment of the structure is possible and more suitable ways to eliminate or minimize the source of decay are presented. Also, the importance of upgrading a resistant model may be seen in terms of costs, such that it is preferable to have costs in inspection and assessment compared to the possibility of bad performance or even failure of a structure.

Although upgrading a model may indicate higher or lower levels of reliability of an existing structure when compared to a *prior* assumed model, it is erroneous to conclude that upgrading a model leads to a better or worse level of reliability. Actually, updating a model will only provide a more accurate and precise definition of the structural behaviour of a specific element or system of elements, both in terms of reliability and robustness.

For the first example a time depending robustness index was proposed with consideration to long term decay phenomenon in timber structures and the design time considered for that structure.

Regarding the second example, correlations between destructive tests and NDT / MDT were used in order to incorporate an upgrading procedure for the compression strength parallel to grain. The uncertainty regarding those correlations was modelled through a parameter given by a Maximum Likelihood method. The importance of uncertainty was concluded to be preponderant in the analysis of the upgraded resistant parameter. The results from each NDT test were compared to reference models and it was found that for this specific case the results gathered through Pilodyn tests gave the better approximation.

In retrospective, this work presented different procedures and methodologies for safety assessment of timber structures in both theoretical and practical views. The originality of this work is mainly found in the attempt of implementation of procedures for reassessment of timber structures regarding data upgraded by NDT and MDT results. For that, both design and life expecting models were considered and analysed.

Further investigation must be considered in order to reach a better framework and methodology to quantify the influence of data upgrading in safety assessment and, more importantly, to reach a common basis of comparison between different engineers. Other techniques rather than Bayesian methods are also to be taken into account, since experimental results are often given by discrete values and not by a well known distribution. Redundant structures as well as three dimensional structures are also to be studied in order to assess the importance in upgrading the resistant models, especially for the key elements of those structures. Also parallel and series systems are to be considered when considering decay models with upgraded information. Regarding the importance of correctly describing and quantifying the uncertainty of the NDT and MDT used for upgrading, more data must be analysed to better model the related POD and POS of those tests.

## REFERENCES

- Asso, F. O. (1985). "Materiales de Construcción", 7<sup>th</sup> edition. editorial dossat, s.a., Madrid, Spain, pp. 449-463.
- Baker, J. W., Schubert, M., and Faber, M. H. (2008), "On the Assessment of Robustness," *Journal of Structural Safety*, 30, pp. 253-267.
- Barrett, J.D., Foschi, R.O. (1978). "Duration of load and probability of failure in wood. Part 1: modelling creep rupture". *Can J Civil Eng* 1978;5(40), p. 505-14
- Biondini, F. (2008). "Robustness, Redundancy and Indeterminacy", HE2008, Rome, November
- Biondini, F. Frangopol, D.M. and Restelli, S. (2008). "On Structural Robustness, Redundancy and Static Indeterminacy", *Structures 2008: Crossing Borders*, ASCE
- Brites, R.D., Neves, L.C., Machado, J.S. e Lourenço, P.B. (2008). "Avaliação da Segurança de Cobertura Tradicional de Madeira Sujeita a Degradação Biológica". CINPAR 08
- Casasús, A.G. et al (1997). "Especies de madera para carpintería, construcción y mobiliario". Asociación de Investigación Técnica de las Industrias de la Madera y Corcho, Espanha.
- CEN, (2002a). ENV 1990 – "Eurocode 0 – Basis of Structural Design". European Committee for Standardization (CEN), Brussels.
- CEN, (2002b). ENV 1991-1-1 – "Eurocode 1 – Actions on structures – Part 1-1: General actions – Densities, self-weight, imposed loads for buildings". European Committee for Standardization (CEN), Brussels
- CEN, (2004) ENV 1995-1-1 – "Eurocode 5 - Design of Timber Structures - Part 1-1: General - Common rules and rules for buildings", European Committee for Standardization (CEN), Brussels.
- CEN, (2005). ENV 1991-1-4 – "Eurocode 1 – Actions on structures – Part 1-4: General actions – Wind actions", European Committee for Standardization (CEN), Brussels,
- CEN, (2006). Eurocode 1-1-7 – "Actions on structures. Part 1-7: General actions - Accidental actions European Standard EN 1991-1-7". European Committee for Standardization. Brussels.
- Del Seno, M., Piazza, M., Tomasi, R. (2004), "A pseudo-ductile approach design of glued laminated timber beams", *World Conference on Timber Engineering*, Lahti.
- Dietsch, P., Kreuzinger, H. and Winter, S. (2009), "The Bad Reichenhall Ice-Arena Collapse – Robustness Considerations", 5th COST E55 Workshop, Trondheim, Norway.
- Ellingwood, B. R., Smilowitz, R., Dusenberry, D. O., Duthinh, D., and Carino, N. J. (2007), "Best Practices for Reducing the Potential for Progressive Collapse in Buildings" Technical, Gaithersburg: National Institute of Standards and Technology.
- Feio, A. (2005). "Inspection and Diagnosis of Historical Timber Structures: NDT Correlations and Structural Behaviour". Ph.D. thesis, University of Minho, Portugal
- Fink, G., Steiger, R. and Köhler, J. (2009). "Definition of Robustness and related terms". Joint Workshop of COST Actions TU0601 and E55 September 21-22 2009, Ljubljana, Slovenia
- Foschi, R.O., Folz, B.R., Yao, F.Z. (1989). "Reliability-based design of wood structures" *Structural research series*, Rep. No. 34, Dep. of Civil Engineering, University of British Columbia, Vancouver, Canada
- Frangopol D.M., and Curley, J.P. (1987), "Effects of Damage and Redundancy on Structural Reliability", *Journal of Structural Engineering*, 113, 1533-1549.
- Fu, G. and Frangopol, D., M.,(1990) "Balancing weight, system reliability and redundancy in multiobjective optimization framework", *Journal of Structural Safety*, vol. 7, pp. 165-175
- Gerhards, C.C. (1979). "Time-related effects on wood strength: a linear cumulative damage theory". *Wood Science* 1979;11(3), p. 139-44
- Gollwitzer, S. and Rackwitz, R. (1986), "Comparison of Numerical Schemes for the Multinormal Integral", Springer Verlag. In *Proceedings of the first IFIP WG 6.5 Working Conference on Reliability and Optimization of Structural Systems*, P. Thoft-Christensen (ed.) pp. 157-174.
- Gollwitzer, S., Rackwitz, R. (1990), "On the reliability of Daniels systems, *Structural Safety*", vol. 7, pp. 229-243, Elsevier Science Publishers B.V.

- Hohenbichler, M. (1984), “An Asymptotic Formula for the Probability of Intersections”. *Berichte zur Zuverlässigkeitstheorie der Bauwerke*, Heft 69, LKI, Technische Universität München, pp. 21-48.
- Isaksson T. (1999) “Modelling the Variability of Bending Strength in Structural Timber. PhDthesis, Lund Institute of Technology”, Report TVBK-1015.
- ISO 19902:2007. “Petroleum and Natural Gas Industries - Fixed Steel Offshore Structures”.
- ISO 2007: ISO Standard 22111 – “Bases for design of structures – General requirements”. International Organization for Standardization.
- Joint Committee on Structural, Project Team Eurocode 1.1 (1996), Background documentation Eurocode 1 (ENV 1991) Part 1: Basis of Design, Working Document, European Convention for Constructional Steelwork, First Edition
- Joint Committee on Structural Safety (2001). “JCSS Probabilistic Model Code, Part 2: Load Models”. Probabilistic Model Code, Internet Publication: [www.jcss.ethz.ch](http://www.jcss.ethz.ch)
- Joint Committee on Structural Safety (2008). “Risk Assessment in Engineering Principles”, System Representation & Risk Criteria. JCSS Publication, <http://www.jcss.ethz.ch/>.
- Joint Committee on Structural Safety, (2001), “Probabilistic Assessment of Existing Structures”, edited by D. Diamantidis, RILEM Publications
- Joint Committee on Structural Safety, (2006), “JCSS Probabilistic Model Code, Part 3: Resistance Models – 3.5 Properties of Timber”. Probabilistic Model Code, Internet Publication: [www.jcss.ethz.ch](http://www.jcss.ethz.ch).
- Joint Committee on Structural Safety. (2000), “JCSS Probabilistic Model Code, Part 1: Basis of Design”, Probabilistic Model Code, Internet Publication: [www.jcss.ethz.ch](http://www.jcss.ethz.ch).
- Kirkegaard, P. H., Sørensen, J. D. (2009). “Robustness Analysis of Kinetic Structures” Proceedings of the International Association for Shell and Spatial Structures (IASS) Symposium 2009, Valencia, Spain
- Köhler, J. and Svensson, S. (2002). “Probabilistic modelling of duration of load effects in timber structures”. Proc. CIB W18 meeting in Kyoto, September 2002, Japan
- Köhler, J., Sørensen, J. D., Faber, H.M. (2007), “Probabilistic modelling of timber structures”, *Journal of Structural Safety*, vol. 29, issue 4, pp. 255-267.
- Kuklík, P. (2010), SAHC SA5 lectures, Advanced Masters in Structural Analysis of Monuments and Historical Constructions, Erasmus Mundus Programme, University of Minho, Guimarães, Portugal
- Leicester, R.H. (2001), “Engineered durability for timber construction”, John Wiley & Sons, Ltd., CSIRO, Highett, Australia, pp 216-227, p. 216-227.
- Madsen, H.O., Krenk, S. and Lind, N.C. (1986), “Methods of Structural Safety”, Prentice-Hall Inc., Englewood Cliffs, NJ, 1986
- Melchers, R.E. (1999), “Structural Reliability Analysis and Prediction”, Second Edition. John Wiley & Sons, INC., New York.
- Munch-Andersen, J e Dietsch, P. (2009). “Robustness considerations from failures in two large-span timber roof structures”. Joint Workshop of COST Actions TU0601 and E55 September 21-22 2009, Ljubljana, Slovenia
- Nair, R. S. (2006), “Preventing Disproportionate Collapse”. *Journal of Performance of Constructed Facilities*, 20(4): pp. 309-314.
- NP EN 1194:1999. (1999) “Estruturas de Madeira – Madeira lamelada-colada – Classes de resistência e determinação dos valores característicos”, IPQ, Lisboa.
- Park, S., Choi, S., Sikorsky, C. and Stubbs, N. (2004), “Efficient method for calculation of system reliability of a complex structure”, *International Journal of Solids and Structures* , vol. 41, pp. 5035–5050.
- Ramos, L. (2010), SAHC SA4 lectures, Advanced Masters in Structural Analysis of Monuments and Historical Constructions, Erasmus Mundus Programme, University of Minho, Guimarães, Portugal
- Ranta-Maunus, A. (2004), “Theoretical and Practical Aspects of the Reliability Analysis of Timber Structures”, WCTE 2004 Conference, Lahti, Finland.
- Restelli, S. (2007), “Measure of Structural Robustness of Deteriorating Systems”, Degree Thesis, Politecnico di Milano, Milan, Italy, (In Italian).

- Rodrigues, R.O., (2004). “Construções Antigas de Madeira: Experiência de obra e reforço estrutural”. Civil Engineering Masters thesis, University of Minho, Guimarães, Portugal
- Schneider, J. (1997), “Introduction to Safety and Reliability of Structures”, Structural Engineering Documents, Zurich, Switzerland.
- SIA 2004: Standard SIA 260 – “Basis of Structural Design”. Swiss Society of Engineers and Architects. Zurich.
- Sørensen, J.D. (2003), “Statistical analysis using the Maximum-Likelihood Method”, Aalborg University, Aalborg, Denmark
- Sørensen, J. D. (2004), “Notes in Structural Reliability Theory and Risk Analysis”, Aalborg University.
- Sørensen, J.D., Svensson, S. And Stang, B.D. (2005). “Reliability-based calibration of load duration factors for timber structures” *Journal of Structural Safety* 27 (2), Elsevier, p.153-169.
- Sousa, H.S, Lourenço, P.L e Neves, L.C. (2010). “Avaliação de Segurança de Estruturas de Madeira através de Análise Probabilística”, Reabilitar2010 National Conference, Lisbon, Portugal
- Sousa, H.S. (2009). “Avaliação de Segurança de Estruturas de Madeira por meio de Métodos não destrutivos e Análise Estocástica”, Graduating Report in Civil Engineering, University of Minho (in Portuguese).
- Starossek, U., Haberland, M. (2008), “Approaches to measures of structural robustness”, IABMAS 08, International conference on Bridge Maintenance, Safety and Management, Seoul.
- Thelandersson, S and Honfi, D. (2009). “Behaviour and modelling of timber structures with reference to robustness”. Joint Workshop of COST Actions TU0601 and E55 September 21-22 2009, Ljubljana, Slovenia
- Thoft-Christensen, P. and Murotsu, Y (1986), “Application of Structural Systems Reliability Theory”. Springer Verlag.
- Vrouwenvelder, T., and Sørensen, J. D. (2009), “Robustness of Structures, Eu Cost Action Tu0601”, ICOSSAR 2009 - 10th International Conference on Structural Safety and Reliability, Osaka, Japan.
- Wang, C, Leicester, R.H. e Nguyen, M. (2008), “Probabilistic procedure for design of untreated timber poles in-ground under attack of decay fungi”, *Reliability Engineering and System Safety*, Internet Publication: [www.sciencedirect.com](http://www.sciencedirect.com), pp. 476-481.

## ANNEXES

### *Annex A: Different types of prior, posterior and predictive distributions*

#### **Normal distribution with unknown mean**

The stochastic variable  $X$  is normal distributed:

$$f_X(x|\mu, \sigma) = f_N(x|\mu, \sigma) = \frac{1}{\sigma\sqrt{2\pi}} \exp\left(-\frac{1}{2}\left(\frac{x-\mu}{\sigma}\right)^2\right) \quad (\text{A-1})$$

Uncertain parameter:  $\mu$

Prior density function (normal distribution):

$$f'_\mu(\mu) = f_N(\mu|\mu', \sigma') = \frac{1}{\sigma'\sqrt{2\pi}} \exp\left(-\frac{1}{2}\left(\frac{\mu-\mu'}{\sigma'}\right)^2\right) \quad (\text{A-2})$$

Posterior density function (normal distribution):

$$f''_\mu(\mu|\hat{x}) = f_N(\mu|\mu'', \sigma'') \quad (\text{A-3})$$

where

$$\mu'' = \frac{n\bar{x}\sigma'^2 + \mu'\sigma^2}{n\sigma'^2 + \sigma^2} \quad (\text{A-4})$$

$$\sigma''^2 = \frac{\sigma'^2\sigma^2}{n\sigma'^2 + \sigma^2} \quad (\text{A-5})$$

$$\bar{x} = \frac{1}{n} \sum_{i=1}^n \hat{x}_i \quad , \quad \hat{x} \text{ are the test results} \quad (\text{A-6})$$

Predictive function (normal distribution):

$$f_X(x|\hat{x}) = f_N(x|\mu'', \sigma''') \quad (\text{A-7})$$

where

$$\sigma''' = \sqrt{\sigma'^2\sigma^2} \quad (\text{A-8})$$

#### **Normal distribution with unknown mean**

The stochastic variable  $X$  is normal distributed:

$$f_X(x|\mu, \sigma) = f_N(x|\mu, \sigma) = \frac{1}{\sigma\sqrt{2\pi}} \exp\left(-\frac{1}{2}\left(\frac{x-\mu}{\sigma}\right)^2\right) \quad (\text{A-9})$$

Uncertain parameter:  $\sigma$



Prior density function (Invers-Gamma-2 distribution):

$$f'_\sigma(\sigma) = f_{i\gamma}(\sigma|\omega', v') = \frac{2}{\Gamma((v' + 2)/2)} \frac{\left(\frac{1}{2}\right) (v' \omega' / \sigma^2)^{(v'+2)/2}}{\left(\frac{1}{2}\right) (v' \omega')^{1/2}} \exp\left(-\frac{1}{2} \frac{v' \omega'}{\sigma^2}\right) \quad (\text{A-10})$$

Posterior density function (Invers-Gamma-2 distribution):

$$f''_\sigma(\sigma) = f_{i\gamma}(\sigma|\omega'', v'') \quad (\text{A-11})$$

where

$$v'' = v' + v \quad (\text{A-12})$$

$$\omega'' = (\omega' v' + \omega v) / v'' \quad (\text{A-13})$$

$$\omega = \frac{1}{v} \sum_{i=1}^v (\hat{x}_i - \mu)^2, \quad \hat{x} \text{ are the test results} \quad (\text{A-14})$$

Posterior distribution function (Invers-Gamma-2 distribution):

$$F''_\sigma(\sigma) = 1 - \frac{\Gamma\left(\frac{v'' \omega'' v''}{2 \sigma^2} \frac{v''}{2}\right)}{\Gamma\left(\frac{v''}{2}\right)} \quad (\text{A-15})$$

where

$$\Gamma(a) = \int_0^{\infty} \exp(-t) t^{a-1} dt \quad (\text{A-16})$$

$$\Gamma(a, b) = \int_0^{\infty} \exp(-t) t^{b-1} dt \quad (\text{A-17})$$

Predictive density function (Student distribution):

$$\begin{aligned} f_X(x|\hat{x}) &= f_S(x|\mu, \omega'', v'') = \\ &= \int f_N(x|\mu, \sigma) f_{i\gamma 2}(\sigma|\omega'', v'') d\sigma = \\ &= \frac{v''(v''/2)}{\sqrt{\omega''} B(1/2, 1/2 v'')} \left[ v'' + \frac{(x - \mu)^2}{\omega''} \right]^{-(v''+1)/2} \end{aligned} \quad (\text{A-18})$$

where  $B$  is the beta function.

### Normal distribution with unknown mean

The stochastic variable  $X$  is normal distributed:

$$f_X(x|\mu, \sigma) = f_N(x|\mu, \sigma) = \frac{1}{\sigma\sqrt{2\pi}} \exp\left(-\frac{1}{2}\left(\frac{x-\mu}{\sigma}\right)^2\right) \quad (\text{A-19})$$

Uncertain parameter:  $\mu, \sigma$

Prior density function (Normal-Invers-Gamma-2 distribution):

$$f'_{\mu, \sigma}(\mu, \sigma) = f_N\left(\mu'|\bar{x}', \frac{\sigma}{\sqrt{n'}}\right) f_{i\gamma 2}(\sigma|v', \nu') \quad (\text{A-20})$$

Posterior density function (Normal-Invers-Gamma-2 distribution):

$$f''_{\mu, \sigma}(\mu, \sigma|\hat{x}) = f_N\left(\mu'|\bar{x}'', \frac{\sigma}{\sqrt{n''}}\right) f_{i\gamma 2}(\sigma|v'', \nu'') \quad (\text{A-21})$$

where

$$n'' = n' + n \quad (\text{A-22})$$

$$\bar{x}'' = (n'\bar{x}' + n\bar{x})/n'' \quad (\text{A-23})$$

$$v'' = (v'v' + n'\bar{x}'^2 + \nu v + n\bar{x}^2 - n''\bar{x}''^2)/v'' \quad (\text{A-24})$$

$$\nu'' = \nu' + \delta(n') + \nu + \delta(n) - \delta(n'') \quad (\text{A-25})$$

$$\bar{x} = \frac{1}{n} \sum_{i=1}^n \hat{x}_i \quad , \quad \hat{x} \text{ are the test results} \quad (\text{A-26})$$

$$v = \frac{1}{n-1} \sum_{i=1}^n (\hat{x}_i - \bar{x}')^2 \quad (\text{A-27})$$

$$\nu = n - 1 \quad (\text{A-28})$$

Posterior distribution function for  $\sigma$ :

$$F''_{\sigma}(\sigma|\hat{x}) = 1 - \frac{\Gamma\left(\frac{\nu''}{2}, \frac{v''}{\sigma^2}, \frac{\nu''}{2}\right)}{\Gamma\left(\frac{\nu''}{2}\right)} \quad (\text{A-29})$$

Posterior distribution function for  $\mu$  given  $\sigma$ :

$$F''_{\mu|\sigma}(\mu|\sigma, \hat{x}) = \Phi\left(\frac{\mu - \bar{x}''}{\sigma/\sqrt{n''}}\right) \quad (\text{A-30})$$

Predictive density function (Student distribution):

$$f_X(x, \hat{x}) = f_S\left(x|\bar{x}'', v''\frac{n''+1}{n''}, \nu''\right) \quad (\text{A-31})$$

### Lognormal distribution

The density function:

$$f_X(x|\mu, \sigma) = \frac{1}{x\sigma\sqrt{2\pi}} \exp\left(-\frac{1}{2}\left(\frac{\ln x - \mu}{\sigma}\right)^2\right) \quad (\text{A-32})$$

The lognormal stochastic variable  $X$  can be treated in the same way as a normal distributed variable since  $Y = \ln X$  is a normal distributed with standard deviation:

$$\sigma_Y = \sqrt{\ln\left(\frac{\sigma^2}{\mu^2} + 1\right)} \quad (\text{A-33})$$

and expected value:

$$\mu_Y = \ln\mu - \frac{1}{2}\sigma_Y^2 \quad (\text{A-34})$$

### Gumbel distribution

The distribution function:

$$F_X(x|\alpha, u) = \exp\left(-\exp(-\alpha(x - u))\right) \quad (\text{A-35})$$

The density function:

$$f_X(x|\alpha, u) = \alpha \exp\left(-\alpha(x - u) - \exp(-\alpha(x - u))\right) \quad (\text{A-36})$$

Uncertain parameter:  $u$

The prior density:

$$f'_u(u) = \exp(n'\alpha u - t'\exp(\alpha u)) \alpha t'^{(n')} / \Gamma(n') \quad (\text{A-37})$$

The posterior density function:

$$f''_u(u|\hat{x}) = \exp(n''\alpha u - t''\exp(\alpha u)) \alpha t''^{(n'')} / \Gamma(n'') \quad (\text{A-38})$$

where

$$n'' = n + n' \quad (\text{A-39})$$

$$t'' = t + t' \quad (\text{A-40})$$

$$t = \sum_{i=1}^n \exp(-\alpha \hat{x}_i) \quad , \quad \hat{x} \text{ are the test results} \quad (\text{A-41})$$

The posterior distribution:

$$F_u''(u|\hat{x}) = \int_{-\infty}^u \exp(n''\alpha z - t''\exp(\alpha z)) \alpha t''^{(n'')} / \Gamma(n'') dz \quad (\text{A-42})$$

The predictive density function:

$$f_X(x|\hat{x}) = n'' \left[ 1 + \frac{1}{t''} \exp(-\alpha x) \right]^{-(n''+1)} \frac{a}{t''} \exp(-\alpha x) \quad (\text{A-43})$$

The predictive distribution function:

$$F_X(x|\hat{x}) = \left[ 1 + \frac{1}{t''} \exp(-\alpha x) \right]^{-n''} \quad (\text{A-44})$$

### Weibull distribution

The distribution function:

$$F_X(x|\varepsilon, u, k) = 1 - \exp\left(-\left(\frac{x - \varepsilon}{u}\right)^k\right) \quad (\text{A-45})$$

The density function:

$$f_X(x|\varepsilon, u, k) = \frac{k}{u} \left(\frac{x - \varepsilon}{u}\right)^{k-1} \exp\left(-\left(\frac{x - \varepsilon}{u}\right)^k\right) \quad (\text{A-46})$$

Uncertain parameter:  $u$

The prior density function:

$$f_u'(u) = \frac{1}{\Gamma(n' - 1/k)} u^{-(n'k)} \exp(-u^{-k}t') k t'^{(n' - 1/k)} \quad (\text{A-47})$$

The posterior density function:

$$f_u''(u|\hat{x}) = \frac{1}{\Gamma(n'' - 1/k)} u^{-(n''k)} \exp(-u^{-k}t'') k t''^{(n'' - 1/k)} \quad (\text{A-48})$$

where

$$n'' = n + n' \quad (\text{A-49})$$

$$t'' = t + t' \quad (\text{A-50})$$

$$t = \sum_{i=1}^n \exp(\hat{x}_i - \varepsilon)^k, \quad \hat{x} \text{ are the test results} \quad (\text{A-51})$$

The posterior distribution function:

$$F_u''(u|\hat{x}) = 1 - \frac{\Gamma\left(n'' - \frac{1}{k}, t''u^{-k}\right)}{\Gamma(n'' - 1/k)} \quad (\text{A-52})$$

The predictive density function:

$$f_X(x|\hat{x}) = (n'' - 1/k) \left[1 + \frac{(x - \varepsilon)^k}{t''}\right]^{-(n''-1/k+1)} \frac{k}{t''} (x - \varepsilon)^{(k-\varepsilon)} \quad (\text{A-53})$$

The predictive distribution:

$$F_X(x|\hat{x}) = 1 - \left[1 + \frac{(x - \varepsilon)^k}{t''}\right]^{-(n''-1/k)} \quad (\text{A-54})$$

### Exponential distribution

The density function:

$$f_X(x|\lambda) = \lambda \exp(-\lambda) \quad (\text{A-55})$$

Uncertain parameter:  $\lambda$

The prior density function (Gamma distribution):

$$f_\lambda'(\lambda) = \frac{v'^{h'} \lambda^{(h'-1)} \exp(-v'\lambda)}{\Gamma(h')} \quad (\text{A-56})$$

The posterior density function (Gamma distribution):

$$f_\lambda''(\lambda|\hat{x}) = \frac{v''^{h''} \lambda^{(h''-1)} \exp(-v''\lambda)}{\Gamma(h'')} \quad (\text{A-57})$$

The posterior distribution:

$$F_\lambda''(\lambda|\hat{x}) = \frac{\Gamma(v''\lambda, h'')}{\Gamma(h'')} \quad (\text{A-58})$$

where

$$v'' = v' + \sum_{i=1}^n \hat{x}_i \quad , \quad \hat{x} \text{ are the test results} \quad (\text{A-59})$$

$$h'' = h' + n \quad (\text{A-60})$$

The predictive density function (Invers-beta distribution):

$$f_X(x|\hat{x}) = \frac{h'' v''^{h''}}{(x + v'')^{(h''+1)}} \quad (\text{A-61})$$

The predictive distribution function:

$$F_X(x|\hat{x}) = \frac{B(x/(x + v''), v'', h'')}{B(1, h'')} \quad (\text{A-62})$$

where

$$B(a, b) = \Gamma(a)\Gamma(b)/\Gamma(a + b) \quad (\text{A-63})$$

$$B(x, a, b) = \int_0^x t^{(a-1)} (1 - t)^{(b-1)} \quad (\text{A-64})$$

### Fréchet Distribution

The density function:

$$f_X(x|v, k) = \frac{k}{v} \left(\frac{v}{x}\right)^{k+1} \exp\left[-\left(\frac{v}{x}\right)^k\right] \quad (\text{A-65})$$

The distribution function:

$$F_X(x|v, k) = \exp\left[-\left(\frac{v}{x}\right)^k\right] \quad (\text{A-66})$$

Uncertain parameters: v

Posterior density function / Distribution:

$$f_V(v) = \frac{v^{nk-q} \exp[-v^k t] k t^{n+\frac{1-q}{k}}}{\Gamma(n + (1 - q)/k)} \quad (\text{A-67})$$

Posterior distribution function

$$F_V(v) = \frac{\Gamma(tv^k, n + (1 - p)/k)}{\Gamma(n + (1 - p)/k)} \quad (\text{A-68})$$

where

$$n'' = n + n' \quad (\text{A-69})$$

$$t'' = t + t' \quad (\text{A-70})$$

$$t = \sum_{i=1}^n [\hat{x}_i]^{-k} \quad , \quad \hat{x} \text{ are the test results} \quad (\text{A-71})$$

$$q \approx 0.55k \text{ for } k > 1.0 \quad (\text{A-72})$$

The predictive density function (Invers-beta distribution):

$$f_X(x|\hat{x}) = \left(n'' + \frac{1-q}{k}\right) \left(1 - \frac{x^{-k}}{t''}\right)^{-\left(n'' + \frac{1-q}{k} + 1\right)} \frac{k}{t''} \frac{1}{x^{(k+1)}} \quad (\text{A-73})$$

The predictive distribution function:

$$F_X(x|\hat{x}) = \left(1 + \frac{x^{-k}}{t''}\right)^{-\left(n'' + \frac{1-q}{k}\right)} \quad (\text{A-74})$$

**Annex B: t-student distribution**

The table in this section contains some of the values for the calculus of a t-student distribution.

The first column represents the degree of freedom  $\nu$  for each row. The numbers on the same row represent, for each column, the probabilities of values above the values of  $t$  of each row.

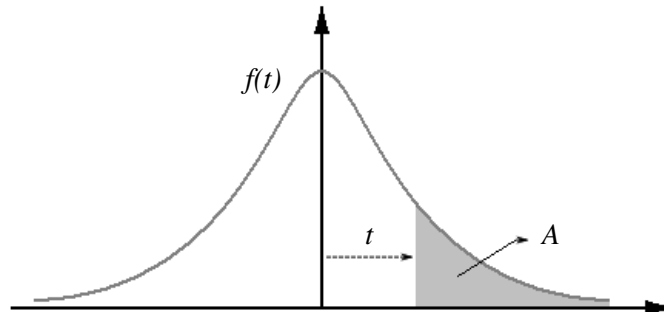

Figure B.1: t-student distribution and parameters for Table B.1

Table B.1: Values of t-student distribution

$\nu/A$	0,2500	0,2000	0,1500	0,1000	0,0500	0,0250	0,0100	0,0050	0,0025	0,0010	0,0005
1	1,000	1,376	1,963	3,078	6,314	12,710	31,820	63,660	127,300	318,300	636,600
2	0,816	1,061	1,386	1,886	2,920	4,303	6,965	9,925	14,090	22,330	31,600
3	0,765	0,978	1,250	1,638	2,353	3,182	4,541	5,841	7,453	10,210	12,920
4	0,741	0,941	1,190	1,533	2,132	2,776	3,747	4,604	5,598	7,173	8,610
5	0,727	0,920	1,156	1,476	2,015	2,571	3,365	4,032	4,773	5,893	6,869
6	0,718	0,906	1,134	1,440	1,943	2,447	3,143	3,707	4,317	5,208	5,959
7	0,711	0,896	1,119	1,415	1,895	2,365	2,998	3,499	4,029	4,785	5,408
8	0,706	0,889	1,108	1,397	1,860	2,306	2,896	3,355	3,833	4,501	5,041
9	0,703	0,883	1,100	1,383	1,833	2,262	2,821	3,250	3,690	4,297	4,781
10	0,700	0,879	1,093	1,372	1,812	2,228	2,764	3,169	3,581	4,144	4,587
11	0,697	0,876	1,088	1,363	1,796	2,201	2,718	3,106	3,497	4,025	4,437
12	0,695	0,873	1,083	1,356	1,782	2,179	2,681	3,055	3,428	3,930	4,318
13	0,694	0,870	1,079	1,350	1,771	2,160	2,650	3,012	3,372	3,852	4,221
14	0,692	0,868	1,076	1,345	1,761	2,145	2,624	2,977	3,326	3,787	4,140
15	0,691	0,866	1,074	1,341	1,753	2,131	2,602	2,947	3,286	3,733	4,073
16	0,690	0,865	1,071	1,337	1,746	2,120	2,583	2,921	3,252	3,686	4,015
17	0,689	0,863	1,069	1,333	1,740	2,110	2,567	2,898	3,222	3,646	3,965
18	0,688	0,862	1,067	1,330	1,734	2,101	2,552	2,878	3,197	3,610	3,922
19	0,688	0,861	1,066	1,328	1,729	2,093	2,539	2,861	3,174	3,579	3,883
20	0,687	0,860	1,064	1,325	1,725	2,086	2,528	2,845	3,153	3,552	3,850
21	0,686	0,859	1,063	1,323	1,721	2,080	2,518	2,831	3,135	3,527	3,819
22	0,686	0,858	1,061	1,321	1,717	2,074	2,508	2,819	3,119	3,505	3,792
23	0,685	0,858	1,060	1,319	1,714	2,069	2,500	2,807	3,104	3,485	3,767
24	0,685	0,857	1,059	1,318	1,711	2,064	2,492	2,797	3,091	3,467	3,745
25	0,684	0,856	1,058	1,316	1,708	2,060	2,485	2,787	3,078	3,450	3,725
26	0,684	0,856	1,058	1,315	1,706	2,056	2,479	2,779	3,067	3,435	3,707
27	0,684	0,855	1,057	1,314	1,703	2,052	2,473	2,771	3,057	3,421	3,690
28	0,683	0,855	1,056	1,313	1,701	2,048	2,467	2,763	3,047	3,408	3,674
29	0,683	0,854	1,055	1,311	1,699	2,045	2,462	2,756	3,038	3,396	3,659
30	0,683	0,854	1,055	1,310	1,697	2,042	2,457	2,750	3,030	3,385	3,646
40	0,681	0,851	1,050	1,303	1,684	2,021	2,423	2,704	2,971	3,307	3,551
50	0,679	0,849	1,047	1,299	1,676	2,009	2,403	2,678	2,937	3,261	3,496
60	0,679	0,848	1,045	1,296	1,671	2,000	2,390	2,660	2,915	3,232	3,460
80	0,678	0,846	1,043	1,292	1,664	1,990	2,374	2,639	2,887	3,195	3,416
100	0,677	0,845	1,042	1,290	1,660	1,984	2,364	2,626	2,871	3,174	3,390
120	0,677	0,845	1,041	1,289	1,658	1,980	2,358	2,617	2,860	3,160	3,373
$\infty$	0,674	0,842	1,036	1,282	1,645	1,960	2,326	2,576	2,807	3,090	3,291



**Annex C:** Data from NDT and MDT and corresponded values for compression strength parallel to grain obtained by destructive tests

Table C.1: Test results

Sample number	Type of test					
	Resistograph		Pilodyn		Ultrasounds	
	RM (bit)	$f_{c,o}$ (N/mm <sup>2</sup> )	Depth (mm)	$f_{c,o}$ (N/mm <sup>2</sup> )	$E_{din}$ (N/mm <sup>2</sup> )	$f_{c,o}$ (N/mm <sup>2</sup> )
1	278,08	50,91	7,50	45,42	1588,07	45,42
2	291,05	55,91	7,38	51,44	1763,20	51,44
3	261,20	43,17	8,62	38,33	1370,42	38,33
4	261,89	42,42	7,62	52,36	1482,83	52,36
5	277,09	52,41	8,12	42,94	1154,45	42,94
6	290,11	51,71	8,62	33,24	963,53	33,24
7	282,60	44,06	7,25	50,26	1668,85	50,26
8	270,91	49,11	9,50	32,39	720,85	32,39
9	282,73	56,97	7,75	48,09	1648,05	48,09
10	281,74	44,32	8,00	56,97	1563,44	56,97
11	278,50	50,00	8,25	36,99	981,51	36,99
12	273,10	50,37	7,88	36,37	1004,94	36,37
13	272,03	41,18	7,75	43,20	1314,00	43,20
14	232,18	34,25	6,75	50,08	1462,55	50,08
15	287,51	53,81	8,75	38,70	1233,28	38,70
16	244,68	37,24	7,75	40,18	1511,30	40,18
17	250,00	31,66	8,12	35,04	810,37	35,04
18	230,00	28,18	7,25	46,55	1490,33	46,55
19	282,81	51,13	8,00	48,12	1385,69	48,12
20	286,42	48,60	8,00	43,74	1321,52	43,74
21	307,15	57,42	8,00	48,86	1470,90	48,86
22	288,26	53,51	8,50	33,81	839,80	33,81
23	280,00	43,93	7,62	46,89	1545,55	46,89
24	275,05	53,32	7,75	33,99	953,25	33,99
25	264,17	43,64	7,50	50,69	1595,46	50,69
26	265,00	42,52	8,00	48,12	1843,11	48,12
27	296,37	54,21	8,50	44,33	1337,48	44,33
28	268,05	48,18	7,88	38,88	1118,86	38,88
29	259,03	35,13	8,25	42,24	1443,16	42,24
30	300,33	56,80	8,00	41,71	1399,84	41,71
31	274,89	53,67	7,25	45,08	1653,92	45,08
32	273,70	46,60	8,50	33,56	1118,82	33,56
33	274,72	52,46	7,50	45,58	1244,09	45,58
34	266,87	44,19	7,50	49,79	1351,89	49,79
35	253,56	51,48	9,00	34,82	1173,15	34,82
36	265,32	44,55	7,75	40,68	1591,50	40,68
37	276,48	44,14	8,50	36,44	1154,70	36,44
38	273,13	48,83	8,50	31,70	723,86	31,70
39	265,96	48,46	7,75	46,61	1342,19	46,61
40	288,65	50,34	7,50	49,00	1452,54	49,00
41	282,18	54,18	7,50	35,31	1464,84	35,31
42	285,06	53,23	8,25	49,62	1531,94	49,62
43	276,45	41,92	8,38	34,26	1255,17	34,26
44	283,34	45,12	8,00	49,07	1675,58	49,07
45	284,88	57,70	8,00	45,85	1217,58	45,85
46	280,00	50,22	7,25	41,64	1307,19	41,64
47			7,50	49,12	1985,23	49,12
$\mu$	274,42	47,68	7,95	42,94	1345,34	42,94
$\sigma$	15,56	6,91	0,53	6,51	287,25	6,51
COV [%]	5,67	14,49	6,61	15,17	21,35	15,17