



Aalborg Universitet

AALBORG UNIVERSITY
DENMARK

Autonomous component carrier selection

interference management in local area environments for LTE-advanced

Garcia, Luis Guilherme Uzeda; Pedersen, Klaus; Mogensen, Preben

Published in:
IEEE Communications Magazine

DOI (link to publication from Publisher):
[10.1109/MCOM.2009.5277463](https://doi.org/10.1109/MCOM.2009.5277463)

Publication date:
2009

Document Version
Accepted author manuscript, peer reviewed version

[Link to publication from Aalborg University](#)

Citation for published version (APA):
Garcia, L. G. U., Pedersen, K., & Mogensen, P. (2009). Autonomous component carrier selection: interference management in local area environments for LTE-advanced. *IEEE Communications Magazine*, 47(9), 110-116. <https://doi.org/10.1109/MCOM.2009.5277463>

General rights

Copyright and moral rights for the publications made accessible in the public portal are retained by the authors and/or other copyright owners and it is a condition of accessing publications that users recognise and abide by the legal requirements associated with these rights.

- ? Users may download and print one copy of any publication from the public portal for the purpose of private study or research.
- ? You may not further distribute the material or use it for any profit-making activity or commercial gain
- ? You may freely distribute the URL identifying the publication in the public portal ?

Take down policy

If you believe that this document breaches copyright please contact us at vbn@aub.aau.dk providing details, and we will remove access to the work immediately and investigate your claim.

Autonomous Component Carrier Selection: Interference Management in Local Area Environments for LTE-Advanced

Luis G. U. Garcia, Klaus I. Pedersen, Preben E. Mogensen

Abstract – Low-power base stations such as e.g. Femto-cells are one of the candidates for high data rate provisioning in local areas, such as residences, apartment complexes, business offices and outdoor hotspot scenarios. Unfortunately, the benefits are not without new challenges in terms of interference management and efficient system operation. Due to the expected large number of user-deployed cells, centralized network planning becomes unpractical and new scalable alternatives must be sought. In this article, we propose a fully distributed and scalable solution to the interference management problem in local areas, basing our study case on LTE-Advanced. We present extensive network simulation results to demonstrate that a simple and robust interference management scheme, called autonomous component carrier selection allows each cell to select the most attractive frequency configuration; improving the experience of all users and not just the few best ones; while overall cell capacity is not compromised.

I. Introduction

Low-power base stations, which are also commonly referred to as femto-cells or Home base stations, are low-cost user-deployed cellular base stations using an IP based wired backhaul such as cable or DSL designed to provide service in local environments similar to existing WiFi access points. In a recent contribution [1], the authors indicated the key benefits of low power base stations and outlined the many research opportunities as well as technological and business challenges associated with femto-cells. In [2] an interesting analysis of the financial impact of home base station indicates that current macro-cellular network deployment becomes less economically viable for increasing data rates.

In this light, low-power base stations have recently reemerged as a promising technology component and many believe it will definitely be one of the next steps in the evolutionary path of cellular wireless systems. Dense deployment of low-power base stations offers significantly higher capacity per area as compared to macro cells, arising from using smaller cell sizes and more efficient spatial reuse. On the other hand, installation of many low-power base stations also poses new challenges in terms of interference management and efficient system operation. The latter is especially the case for local areas where end users start installing home base stations without any prior network planning, and without carefully considering where other people in the immediate surroundings have installed other home base stations.

The vast majority of previous contributions in the literature focused on solutions for cases where the user-deployed cells use the same frequency band employed by macro-cells, in which case capacity and coverage gains can dwindle away if macro/femto-cell co-channel interference is left unchecked. Nonetheless, in [3] the authors do point out that femto-to-femto interference also becomes an important issue for indoor performance, especially when femto-cells are densely deployed. Therefore, we pay special attention to the nuances of interference footprint in local area

"(c) 2009 IEEE. Personal use of this material is permitted. Permission from IEEE must be obtained for all other users, including reprinting/ republishing this material for advertising or promotional purposes, creating new collective works for resale or redistribution to servers or lists, or reuse of any copyrighted components of this work in other works."

IEEE Xplore URL:http://ieeexplore.ieee.org/xpls/abs_all.jsp?arnumber=5277463&tag=1

deployments and do not address the complementary and equally interesting case of co-channel interference to/from macro-cells in overlaid networks.

As demonstrated in [4], the interference footprint is significantly different in such local area environments as compared to nicely planned macro cell scenarios, which consequently calls for new self-adjusting interference management techniques. Early work found in [5]-[6] also highlights the need for the ability to self-scale and to self-adjust leading to a new autonomic paradigm with fully “robotic” base stations. The optimal sharing of radio resources between low-power base stations depend on many factors such as the mutual interference coupling among them, the offered traffic for individual access nodes, etc. Finding the optimal division of frequency resources between low power base stations in a highly dynamic and partly chaotic environment is, in general, a non-linear, non-convex NP hard optimization problem. Several interesting contributions are available in the literature, where decomposition of this challenging problem into sub-problems and the use of heuristic algorithms are proposed [7]-[8].

As a case study, we base our investigations on LTE-Advanced, an evolved version of Long Term Evolution (LTE) Release 8, offering downlink peak data rates in excess of 1 Gbps in a bandwidth of 100 MHz [9]. LTE-Advanced is currently in the study item phase in 3GPP, and design targets and new technology features for this system are also aimed for local area scenarios. We propose a fully distributed and scalable solution based on minimal information exchange and negotiation between base stations akin to [10] where each individual low-power base station autonomously makes decisions without involving any centralized network control. The latter is considered to be the most attractive solution, especially for femto type of cells due to the expected large number of deployed cells. Our scheme mainly relies on measurements collected as a by-product of normal system operation, producing useful statistics for interference conditions in the network. In this way, each base station gathers knowledge about the surrounding environment and uses this information in the decision making process. We present network simulation results to further demonstrate that a simple and robust interference management scheme, called autonomous component carrier selection, is possible for LTE-Advanced, providing attractive performance results in local area environments. Although the developed scheme is equally applicable for uplink and downlink, for frequency division duplex (FDD) and time division duplex (TDD), we mainly present it for downlink TDD in this study.

The rest of the paper is organized as follows: Section II presents the system model and outlines the basic assumptions for autonomous component carrier selection. Sections III and IV include more detailed algorithm descriptions and brief comments on the key distinguishing aspects of TDD and FDD deployments. System level simulation results are presented in Section V for an extended local area residential scenario. Finally, the paper is closed in Section VI with concluding remarks and outlook for future studies.

II. System Model

The 100 MHz LTE-Advanced bandwidth consists of 5 component carriers, each with a bandwidth of 20 MHz. The numerology of each component carrier is in coherence with LTE Release 8. The LTE-Advanced spectrum could also be less than 100 MHz, and therefore consist of less than 5 component carriers. The frequency band and spectrum allocation expressed via the number of component carriers and their bandwidth are configurable and known a priori by all base stations, hereafter denoted eNBs to follow the 3GPP terminology. An LTE-Advanced terminal (UE) can be jointly scheduled on multiple component carriers at the same time (i.e. using carrier aggregation), or on a single component carrier as in LTE Release 8.

"(c) 2009 IEEE. Personal use of this material is permitted. Permission from IEEE must be obtained for all other users, including reprinting/ republishing this material for advertising or promotional purposes, creating new collective works for resale or redistribution to servers or lists, or reuse of any copyrighted components of this work in other works."

IEEE Xplore URL:http://ieeexplore.ieee.org/xpls/abs_all.jsp?arnumber=5277463&tag=1

We assume that each eNB always has one active component carrier, denoted the primary component carrier (PCC). The PCC is automatically selected by the eNB when it is first switched on, and is assumed to provide full cell coverage as it will be used by the terminals to camp, to set up new calls, etc. Depending on the offered traffic in the cell and the mutual interference coupling with the surrounding cells, transmission and/or reception on all component carriers may not always be the best solution, especially for cell-edge users. It is therefore proposed that each cell dynamically selects additional component carriers for transmission/reception as well (i.e. a second step after having selected the PCC). The latter is referred to as selection of secondary component carriers (SCC). All component carriers not selected are assumed to be completely muted (uplink/downlink) and not used by the cell.

The proposed scheme uses a distributed and fully scalable approach. That is, selection of primary and secondary carriers is done locally by each cell. Hence, in the proposed concept there is no need for centralized network control. The suggested interference coordination mechanism is part of a hierarchical resource management process. The (re-)selection of component carriers is fairly slow and occurs over a longer time span when compared to fast packet scheduling which is free to operate within the restrictions imposed by the carrier selection process. Our three fundamental premises are:

- Absolute priority of primary over secondary component carriers; avoidance of PCC reselection, while SCCs can be reselected on a faster basis.
- When the offered traffic for an eNB requires more bandwidth, a cell may augment its cell capacity by allocating SCCs.
- An eNB is only allowed to allocate SCCs provided it does not result in excessive interference to the surrounding cells as explained in Section V.

The last item is a policy preventing so-called greedy eNBs from using all the available component carriers for its own sake, even when this results in intolerable interference to the neighboring eNBs. Hence, the proposed scheme for autonomous component carrier selection effectively provides an automatic frequency reuse scheme on a component carrier resolution. This approach ensures protection of both traffic and control channels.

We assume that the allocation of PCC and SCCs is signaled among eNBs (either over the backhaul or over the air) periodically and/or whenever the allocation is changed, so eNBs know which component carriers neighboring eNBs are currently using. This information is of critical importance and is summarized in what we refer henceforth as the Radio Resource Allocation Table (RRAT). Essentially, such tables make femto-cells aware of the existence of other femto-cells. Finally, it is assumed that local eNB measurements are available, as well as terminal measurements for selection the component carriers. The next section on selection of the primary component carrier deals with the first premise, whereas the secondary component carrier selection scheme described in Section IV embodies the other two assumptions.

III. Primary Component Carrier (PCC) Selection

The proposed autonomous component carrier selection scheme is illustrated in Figure 1 with a simple example. Here there are four existing eNBs, while a new eNB #5 is being switched on, and hence is ready for first selecting its PCC. The current selection of PCC and SCCs is

"(c) 2009 IEEE. Personal use of this material is permitted. Permission from IEEE must be obtained for all other users, including reprinting/ republishing this material for advertising or promotional purposes, creating new collective works for resale or redistribution to servers or lists, or reuse of any copyrighted components of this work in other works."

IEEE Xplore URL:http://ieeexplore.ieee.org/xpls/abs_all.jsp?arnumber=5277463&tag=1

illustrated for each eNB with “P” and “S”, respectively. Component carriers not allocated for PCC or SCC are completely muted, and not used for carrying any traffic.

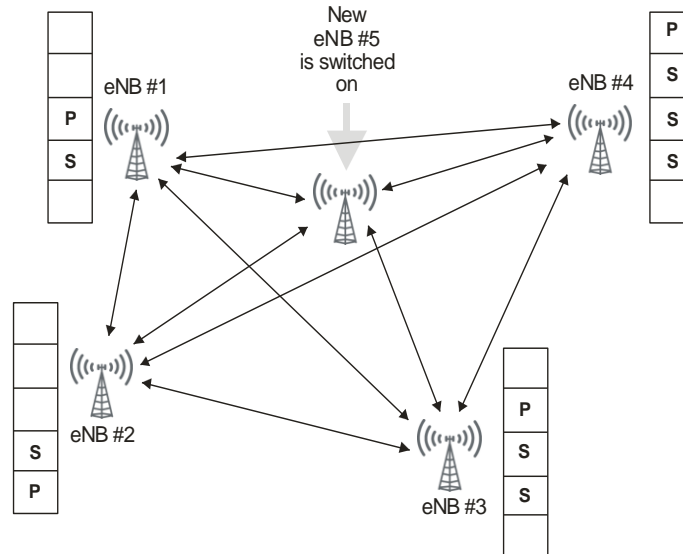

Figure 1 Simple illustration of the autonomous component carrier concept. All eNBs announce their existence and current resource allocation. Additionally, eNBs that are being switched off could signal their leaving.

As the eNB is being initialized, it clearly cannot rely on UE assisted mechanisms; therefore, in addition to the information available in the RRAT, we propose new inter-eNB measurements based on reference signal received power levels for the purpose of estimating the path loss between neighboring eNBs. In FDD systems, this implies that eNBs are able to listen to the downlink band as well. Conversely, in TDD systems, this is not an additional requirement, since uplink and downlink use the same band. It is proposed that the new eNB carry out the measurements on the primary component carrier of the surrounding cells and that knowledge of their corresponding reference symbol transmit power is available (signaled between eNBs), so that the inter-eNB path loss can be estimated. Notice that these inter-eNB path loss measurements need not be frequent as they are only required by new eNB when they are switched on.

Given the aforementioned information, a matrix for initial primary component carrier selection is formed as illustrated in Figure 2, where the eNBs are sorted according to the experienced path loss from the new eNB. As depicted in Figure 2, only the neighboring eNBs within a certain path loss threshold are considered relevant. Neighboring eNBs with higher path loss are not taken into account as there is marginal interference coupling with those. Based on this matrix, we propose the following procedure for initial primary component carrier selection:

1. If there are row entries in the matrix with no selections, then the corresponding component carrier is selected. (If there are multiple of such rows, either select randomly, or select the component experiencing the lowest uplink received interference power). Otherwise go to 2.

"(c) 2009 IEEE. Personal use of this material is permitted. Permission from IEEE must be obtained for all other users, including reprinting/ republishing this material for advertising or promotional purposes, creating new collective works for resale or redistribution to servers or lists, or reuse of any copyrighted components of this work in other works."

IEEE Xplore URL:http://ieeexplore.ieee.org/xpls/abs_all.jsp?arnumber=5277463&tag=1

2. If there are row entries without “P”, select one of those for primary. Select the row entry with lowest number of “S” if there are multiple rows without “P”.
3. If all row entries include “P”, select the component carrier for primary with maximum path loss to the neighboring eNB having the same component carrier as its primary.
4. In cases there are multiple candidate component carriers for primary according to the above rules, select the component carrier with lowest experienced uplink interference. Hence, based on eNB measurements of wideband uplink received interference power.

The above rules essentially assume priority of primary over secondary component carriers, as each eNB should always have one primary component carrier with full cell coverage. The inter eNB path loss measurements are used to ensure that only eNBs with the largest possible path loss separation select the same component carrier for primary.

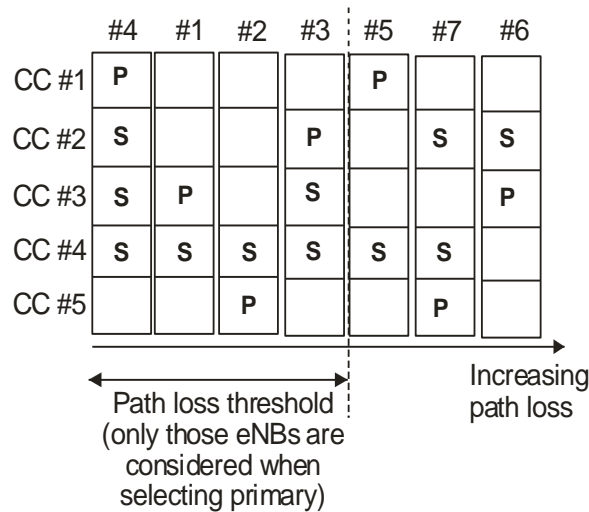

Figure 2 Matrix for initial primary component carrier selection.

It is worth mentioning that the proposed method, solely relying on what the eNBs sense, was found sensitive to the order in which eNBs are turned on in case of very limited number of component carriers to choose from. However, with 5 component carriers, the sensitivity was rather small.

After the new eNB has selected its primary component carrier, the cell is configured and it is ready to transmit and carry traffic. In parallel the eNB shall constantly monitor the quality of the primary component carrier to make sure that it continues to have the desired quality and coverage. If poor quality is detected, recovery actions will be triggered for improving the situation. Such actions can be understood as additional defensive measures not allowing potentially erroneous SCC allocations to catastrophically interfere with neighboring base stations. Recovery actions are the subject of ongoing investigations and are out of the scope of this contribution; nonetheless they may range from interference reduction requests towards neighboring cells where the same component carrier is used as an SCC, to the selection of a new primary component carrier with better quality.

"(c) 2009 IEEE. Personal use of this material is permitted. Permission from IEEE must be obtained for all other users, including reprinting/ republishing this material for advertising or promotional purposes, creating new collective works for resale or redistribution to servers or lists, or reuse of any copyrighted components of this work in other works."

IEEE Xplore URL:http://ieeexplore.ieee.org/xpls/abs_all.jsp?arnumber=5277463&tag=1

IV. Secondary Component Carrier (SCC) Selection

As stated earlier, our scheme imposes certain constraints for selection of secondary component carriers which basically implies that eNBs have to take the interference created towards other cells into account. The goal is a flexible yet simple and efficient sharing of the spectral resources that will not prevent one cell from using the entire spectrum when this is a sensible choice. Granting eNBs the ability to “learn” what sensible means is the key aspect here.

One of the design targets is to maximize the cell throughput for each eNB, however always ensuring that the experienced SINR on PCC and SCC equals at least $(C/I)_{PCC}$ and $(C/I)_{SCC}$, which represent minimum SINR targets expressed in decibels for the primary and secondary component carriers, respectively. These are considered as configurable parameters that could come from O&M, for example. Without loss of generality, we assume that $(C/I)_{PCC}$ is higher than $(C/I)_{SCC}$ as the PCC is assumed to always have full cell coverage while the SCCs may have reduced coverage, i.e. using less transmit power.

Once it is detected that the capacity offered by the PCC alone is not sufficient to carry the offered traffic, the eNB will use two information sources to autonomously decide whether it can allocate additional secondary component carriers. The first source is the aforementioned RRAT which provides real time information on the usage of component carriers by neighboring eNBs. The second piece is the background interference matrix (BIM), which essentially expresses the interference coupling between cells. Now, unlike the selection of the PCC, UE assistance comes into the picture during the creation and maintenance of BIMs.

Each active UE connected to a cell performs downlink measurements of reference signal received power levels which are reported to its serving eNB. These measurements are conducted both towards the serving cell and the surrounding cells (e.g. for handover purposes). Given these UE measurements, the serving eNB calculates a ratio expressed in decibels of own to other cell received signal power. We call it a conditional C/I sample. That essentially allows eNBs to produce an estimate of potential signal quality as perceived by its served UEs. Each time a certain (quantized) value is calculated an occurrence counter is incremented. Eventually, given enough samples, empirical C/I distributions are generated locally by each eNB, one for each detected neighbor. A matrix is then built; we call it the *incoming BIM*.

The C/I value stored in the BIM for each neighboring cell is the value corresponding to a certain outage probability of e.g. 95%. The C/I value is measure of mutual interference coupling between a pair of cells. Therefore, each cell maintains local information on all potential *interfering* cells and a corresponding C/I value. In this example, only 5% of the users are likely to experience C/I values in the downlink lower than the value stored in the BIM. Notice that this C/I is *only* realized if the interfered cell and the interfering cell use the same component carrier simultaneously. As component carriers are likely to experience the same path loss conditions, the BIM is component carrier independent as it is only based on path-loss type of measurements, i.e. it is sufficient for the UEs to measure a single component carrier per cell.

Alternatively, in a more dynamic setting the C/I value stored in the BIM for each neighboring cell could correspond to near real-time conditional C/I values reported by the served UE that is most severely impacted by that particular neighbor. This approach would better capture the effects of far away, yet strong femto-cells that dramatically affect only few UEs e.g. those near windows in a tall building.

In addition to the incoming BIM, eNBs also maintain another BIM table that lists all the potentially *interfered* cells. This BIM is known as the *outgoing BIM*. Basically, it allows a cell to estimate how much interference it generates towards each of its neighbors if it decides to take into

"(c) 2009 IEEE. Personal use of this material is permitted. Permission from IEEE must be obtained for all other users, including reprinting/ republishing this material for advertising or promotional purposes, creating new collective works for resale or redistribution to servers or lists, or reuse of any copyrighted components of this work in other works."

IEEE Xplore URL:http://ieeexplore.ieee.org/xpls/abs_all.jsp?arnumber=5277463&tag=1

use the same CC the neighboring cell already uses. It is linked to the incoming BIM as follows: At the same time an interfering cell entry (cell 2) is added or modified into the incoming BIM of the interfered cell (cell 1), the corresponding interfered cell (cell 1) is added as an entry into the outgoing BIM of the interfering cell (cell 2). The relation between the incoming and outgoing BIM is illustrated in Figure 3.

It is assumed that the reporting of measurements from the UEs to the eNBs for the purpose of BIM is fairly slow in order to minimize the control signaling overhead and measurement burden from this. Similarly, the update rate of the local BIM information in each eNB is also anticipated to be rather slow when compared e.g. to packet scheduling. However, the ideal update rate is the subject of future investigations.

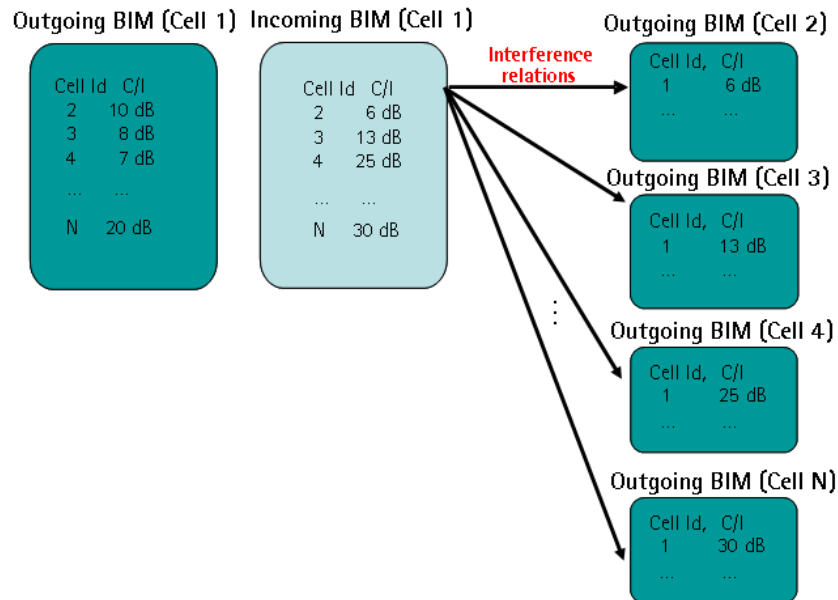

Figure 3 Relation between incoming and outgoing BIM entries.

In possession of the information just described, an eNB is now able to decide whether or not the new allocation(s) will jeopardize any existing allocations based on the target SINR values. As explained, we assume a priori knowledge of the minimum SINR targets $(C/I)_{PCC}$ and $(C/I)_{SCC}$ for primary and secondary component carriers, respectively. The process is fairly straightforward and the interested reader can find a somewhat more formal mathematical description in [11]. In the following, we provide a simplified description of the process.

In essence, for each component carrier not yet allocated to the cell, the eNB calculates a set four differences (in dB). These differences can be understood as neighbor specific BIM entry margins with respect to $(C/I)_{SCC}$ in incoming interference evaluations, and with respect to either $(C/I)_{PCC}$ and $(C/I)_{SCC}$, in outgoing interference evaluations, depending on the component carrier usage of the interfered neighbor. If for any given neighbor using that particular component carrier either as a PCC or SCC, any of the four margins is found to be negative, that particular component carrier is not taken into use and another component carrier is evaluated.

The four differences mentioned earlier correspond in fact to estimated downlink incoming, downlink outgoing, uplink incoming and uplink outgoing SINR margins. It is important to stress that all uplink estimations are rough approximations of the actual uplink

interference situation based on measurements UEs have made on the “interfered” side. The rationale behind this is that incoming/outgoing downlink interference propagates through the same path as the outgoing/incoming uplink interference, thus the downlink C/I estimate contains correlated and useful information. Now, given the hypothetical C/I values in Figure 3, a simple example illustrates the proposed concept. Let us assume cell 1 is evaluating a component carrier that is currently only in use by cell 2 as its PCC and that $(C/I)_{PCC}$ and $(C/I)_{SCC}$ are set to 10 dB and 8 dB, respectively. Since cell 1 intends to use this component carrier as a SCC, the estimated downlink incoming C/I margin is positive, since 6dB is above $(C/I)_{SCC}$. However, allocation will be denied, because the estimated downlink outgoing C/I margin is negative, for 10 dB is lower than $(C/I)_{PCC}$, thus. Uplink incoming and outgoing SINR margins are calculated similarly.

V. Performance Results

We study the potential benefits of our proposed autonomous component carrier selection (ACCS) for LTE-Advanced femto-cells using system-level simulations. Our system operates at 3.4 GHz carrier frequency with up to 100 MHz bandwidth, the maximum transmission power of eNBs is 200 mW (23 dBm) and 3dBi antenna gain is assumed. Even though our scheme does not preclude other power allocations, for simplicity, there is no downlink power control and the total transmission power is evenly divided among the component carriers into which the bandwidth is divided; hence eNBs will only transmit at full power if they employ all component carriers. A simple full-buffer traffic model, i.e. eNBs and UEs always have data to transmit, and a simple round-robin packet scheduler are considered.

Figure 4 depicts the topography of our reference residential scenario. It represents the model for a single indoor floor layout with one eNB (small circle) randomly placed in each 10m x 10m, 4-room residence. The number of uniformly distributed users per residence is fixed to 4. The indoor path-loss and slow fading models used are based on A1-type generalized path loss models for the frequency range 2 - 6 GHz developed in WINNER [12].

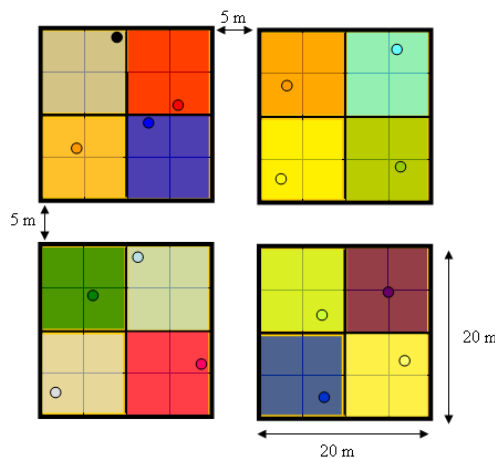

Figure 4 Example of a residential deployment scenario with 16 eNBs with un-coordinated location planning. Walls between residences are modeled differently from the other internal walls.

The simulation tool relies on series of “snapshots”. During each snapshot, path loss, shadowing and the location of devices remain constant. In practice, various system-level practical aspects such as the effects of achievable bandwidth efficiency, control channel overhead, receiver

"(c) 2009 IEEE. Personal use of this material is permitted. Permission from IEEE must be obtained for all other users, including reprinting/ republishing this material for advertising or promotional purposes, creating new collective works for resale or redistribution to servers or lists, or reuse of any copyrighted components of this work in other works."

IEEE Xplore URL:http://ieeexplore.ieee.org/xpls/abs_all.jsp?arnumber=5277463&tag=1

algorithms, etc. all limit the achievable system-level spectral efficiency and a modified Shannon capacity formula according to [13] maps the SINR to corresponding throughput values. Spectrum efficiency is limited to 5.4 bps/Hz since only single transmit and receive antenna configuration has been considered.

Two different spectrum settings are used in our simulation. The first one is the general case of 100 MHz system bandwidth and 5 component carriers of 20 MHz each. In the second one, the available spectrum is 60 MHz and therefore consists of 3 component carriers of 20 MHz each. In all cases $(C/I)_{PCC}$ and $(C/I)_{SCC}$ are set to 10 and 8dB, respectively. Additionally, we consider different deployment densities to evaluate the flexibility and scalability of the proposed concept. In both cases, we assumed private access, also known as closed subscriber group (CSG) mode, whereby UEs can only connect to the eNB in the same residence. Private access is far more challenging than open access from an interference management perspective, since in the latter UEs are served by the eNB with the strongest signal ameliorating the interference scenario. In our simulations, all cells first select their PCC and only then the SCC selection starts. Because of the full load assumption, a cell will always allocate as many SCCs as possible given the existing allocation of its neighbors and interference coupling.

The results are summarized in Figure 5 and Figure 6. The activity factor in the x-axis indicates how dense the deployment is as it represents the share of eNBs that are active. For example, activity factors of 25% and 75% mean that on average 4 and 12 out of the 16 eNBs are active, respectively. Given the private access assumption, eNB inactivity in a given residence, implies inexistence of UEs in that residence. The y-axis is the normalized downlink average cell throughput. The bubble size is proportional to the number inside it, which represents the normalized cell-edge user throughput (5% outage). All values are normalized with respect to the corresponding throughput figure achieved when the entire available spectrum is used by all cells (reuse 1/1).

For the sake of comparison, Figure 5, also presents the performance achieved by genie-aided hard frequency reuse 1/2, whereby severe interfering pair of cells uses complementary halves of the spectrum each. The results clearly show that our concept (ACCS) renders overall cell throughput nearly insensitive to the activity factor, while retaining the benefit of higher cell-edge user throughput. It achieves near four times the throughput provided by reuse 1/1 when all 16 eNBs are active. Despite being a very attractive solution for 100% activity factor, the hard limit of 50 MHz imposed by reuse 1/2 severely limits the overall cell throughput in sparser deployments.

"(c) 2009 IEEE. Personal use of this material is permitted. Permission from IEEE must be obtained for all other users, including reprinting/ republishing this material for advertising or promotional purposes, creating new collective works for resale or redistribution to servers or lists, or reuse of any copyrighted components of this work in other works."

IEEE Xplore URL:http://ieeexplore.ieee.org/xpls/abs_all.jsp?arnumber=5277463&tag=1

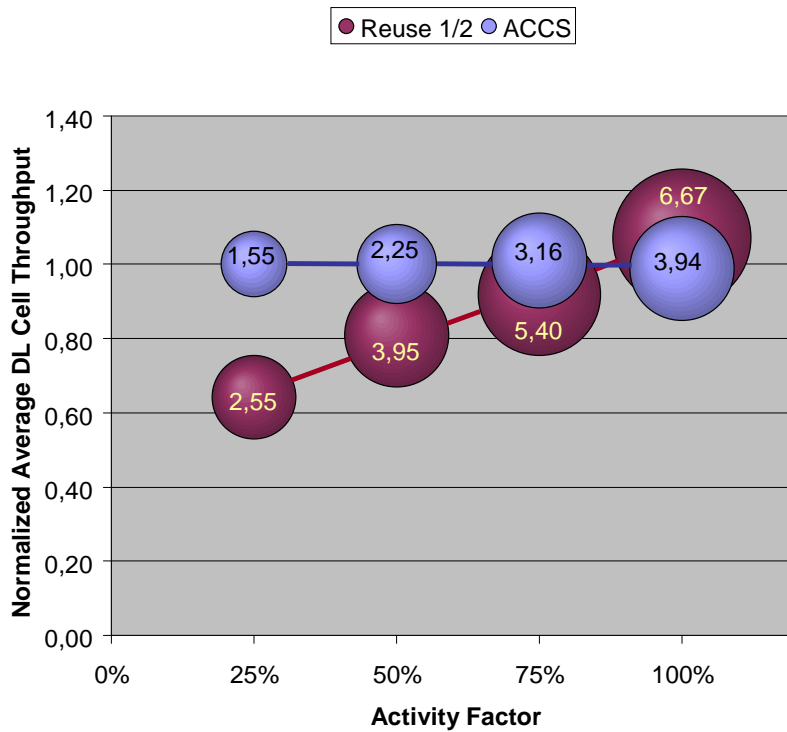

Figure 5 Simulation results for the 100 MHz configuration for variable deployment density levels.

Figure 6 presents the simulation results for a system with 3 component carriers of 20 MHz each. In this case, reuse 1/2, which given the previous results seemed to be a nearly optimal choice for this particular environment assuming 100% activity factor, cannot be achieved in a straightforward way. Now the comparison is performed against reuse 1/3, entailing a hard limit of 20 MHz per cell. The trend is nearly the same with the exception that reuse 1/3 is a poorer choice as its overall cell capacity is quite limited. Similar results as those in Figure 5 and Figure 6 have also been generated for the uplink. Based on those results, we draw similar conclusions, i.e. the ACCS approach is equally valid for the uplink.

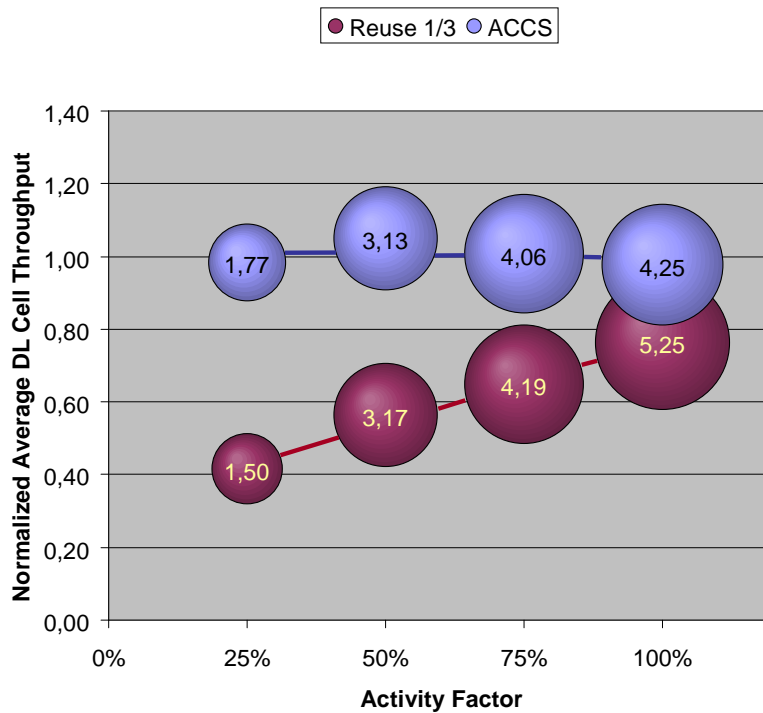

Figure 6 Simulation results for the 60 MHz configuration for variable deployment density levels.

Finally, we highlight that it is possible to trade off overall cell capacity for cell-edge capacity in a controllable manner, by varying the C/I targets of primary and secondary component carriers.

VI. Conclusions

In this contribution we have introduced a simple concept for eNB autonomous selection of component carriers in local area environments. Extensive simulation results provide evidence that the presented concept renders average cell throughput virtually insensitive to the density of neighboring femto-cells, without compromising cell-edge user throughput when compared to universal frequency reuse. Hence, it provides a fully distributed (scalable) and self-adjusting frequency re-use mechanism, which allows for uncoordinated eNB deployment without prior (expensive & manual) network planning. This result is of significant importance as the expected large scale deployment of low-power eNBs will call for interference management techniques. Each cell always selects one, and only one, primary component carrier. Allocation of additional secondary component carriers is possible if and only if the performance impact on neighboring cells is estimated to be acceptable. Apart from the need to standardize the allocation policy, inter-eNB measurements and information exchange processes the concept entails minimal changes to the standard as it relies on existing UE measurement reports. Although not explicitly discussed in this paper, the autonomous component carrier selection concept can be further extended to also handle interference management in heterogeneous networks where macro cells and low-power eNBs (e.g. Femto cells) are operating in the same frequency band. An example of such a related study can be found in [14]. Recovery actions in case the quality of the primary component carrier

"(c) 2009 IEEE. Personal use of this material is permitted. Permission from IEEE must be obtained for all other users, including reprinting/ republishing this material for advertising or promotional purposes, creating new collective works for resale or redistribution to servers or lists, or reuse of any copyrighted components of this work in other works."

IEEE Xplore URL:http://ieeexplore.ieee.org/xpls/abs_all.jsp?arnumber=5277463&tag=1

becomes unacceptable and fair means to distribute the additional capacity of secondary component carriers among competing eNBs are the subject of ongoing investigations.

VIII References

- [1] V. Chandrasekhar, J.G. Andrews and A. Gatherer, "Femtocell Networks: A Survey", in IEEE Communications Magazine, pp. 59-67, September 2008.
- [2] H. Claussen, L.T.W. Ho and L.G. Samuel, "Financial Analysis of a Pico-Cellular Home Network Deployment" in IEEE International Conference on Communications (ICC '07), pp. 5604 – 5609, June 2007.
- [3] Yeh Shu-ping, S. Talwar, Lee Seong-choon and Kim Heechang, "WiMAX femtocells: a perspective on network architecture, capacity, and coverage" in , IEEE Communications Magazine, Vol. 46, Issue 10, pp. 58-65, October 2008.
- [4] Y. Wang, S. Kumar, L. G. U. Garcia, K. I. Pedersen, I. Z. Kovacs, S. Frattasi, N. Marchetti, and P. E. Mogensen, "Fixed Frequency Reuse for LTE-Advanced Systems in Local Area Scenarios," in IEEE Proc. VTC-Spring, April 2009.
- [5] F. J. Mullany, L. T. W. Ho, L. G. Samuel, H. Claussen, "Self-deployment, self-configuration: Critical future paradigms for wireless access networks," in Proc. IFIP TC6 WG6.6 International Workshop on Autonomic Communication WAC, Oct. 2004, Berlin, Germany, and in Lecture Notes on Computer Science LNCS, Springer Verlag, vol. 3457, pp. 58-68, July 2005.
- [6] H. Claussen, "Distributed algorithms for robust self-deployment and self-configuration in autonomous wireless access networks," in Proc. IEEE International Conference on Communications, vol. 4, pp. 1927 - 1932 June 2006, Istanbul.
- [7] G. Li, H. Liu, "Downlink Dynamic Resource Allocation for Multi-Cell OFDMA System", in IEEE Trans. on Wireless Communications, Vol 5. pp. 3451-3459, December 2006.
- [8] M.S. Kang, B.C. Jung, "Decentralized Intercell Interference Coordination in Uplink Cellular Networks Using Sub-band Exclusion", in IEEE Wireless Communications and Networking Conference, April 2009.
- [9] S. Parkvall, et al., "LTE-Advanced – Evolving LTE Towards IMT-Advanced", in IEEE Proc. Vehicular Technology Conference, September. 2008.
- [10] M. Salmenkaita, J. Gimenez, and P. Tapia, "A Practical DCA Implementation for GSM Networks: Dynamic Frequency and Channel Assignment," in Vehicular Technology Conference, April 2001, pp.2529–2533.
- [11] 3GPP Technical document, R1-090235, "Use of Background Interference Matrix for Autonomous Component Carrier Selection for LTE-Advanced", Nokia Siemens Networks, Nokia, February 2009, Available at www.3gpp.org
- [12] WINNER II, D1.1.2, "WINNER II Channel Models part I- Channel Models," Tech. Rep., September 2007.
- [13] P. Mogensen, W. Na, I. Kovacs, F. Frederiksen, A. Pokhariyal, K. Pedersen, T. Kolding, K. Hugl, and M. Kuusela, "LTE Capacity Compared to the Shannon Bound," in IEEE Proc. Vehicular Technology Conference, pp. 1234–1238, April 2007.
- [14] T.H Kim, T.J. Lee, "Throughput Enhancement of Macro and Femto Networks By Frequency Reuse and Pilot Sensing", in IEEE Proc. International Performance,

"(c) 2009 IEEE. Personal use of this material is permitted. Permission from IEEE must be obtained for all other users, including reprinting/ republishing this material for advertising or promotional purposes, creating new collective works for resale or redistribution to servers or lists, or reuse of any copyrighted components of this work in other works."

IEEE Xplore URL:http://ieeexplore.ieee.org/xpls/abs_all.jsp?arnumber=5277463&tag=1

Biographies for paper COMMAG-09-00109 entitled “Autonomous Component Carrier Selection: Interference Management in Local Area Environments for LTE-Advanced” September 2009/Femto Cells

Luis Guilherme Uzeda Garcia (lug@es.aau.dk) received his Electronics Engineer degree from the Universidade Federal do Rio de Janeiro (UFRJ) in 2003 and the M.Sc. degree from COPPE/UFRJ, Brazil in 2006. He also worked at Instituto Nokia de Tecnologia (INdT), Brasília, Brazil as a researcher for nearly four years. He is currently working toward the Ph.D. degree at Aalborg University, Aalborg, Denmark, in close cooperation with Nokia Siemens Networks. His current research interests include radio resource management and concept development for 3GPP Long Term Evolution Advanced (LTE-Advanced).

Klaus Ingemann Pedersen (Klaus.Pedersen@nsn.com) received his M.Sc. E.E. and Ph.D. degrees in 1996 and 2000 from Aalborg University, Denmark. He is currently with Nokia Siemens Networks in Aalborg, Denmark, where he is working as a senior wireless network specialist. His current work is mainly related to radio resource management and 3GPP standardization of Long Term Evolution (LTE) and LTE-Advanced. Have also been working on WCDMA/HSDPA, smart antenna array systems, spatial propagation modelling, among others.

Preben Elgaard Mogensen (Preben.Mogensen@nsn.com) received his MSc. EE. and Ph.D. degrees in 1988 and 1996, respectively, from Aalborg University (AAU), Denmark. From 1999 he has been part time professor at Department of Electronic Systems, AAU, where he is heading the Radio Access Technology (RATE) research section. Preben Mogensen also holds a part time position of Principal Engineer at Nokia Siemens Networks (NSN) – Aalborg, where he is involved in LTE and LTE-Advanced standardization research. Preben Mogensen is author or co-author of more than 170 technical publications within a wide range of areas including: radio wave propagation, advanced antenna technologies, receiver design, frequency assignment, radio resource management and packet scheduling.