



Aalborg Universitet

AALBORG UNIVERSITY
DENMARK

Coordination between Fault-Ride-Through Capability and Overcurrent Protection of DFIG Generators for Wind Farms

Bak-Jensen, Birgitte; Kawady, Tamer A.; Abdel-Rahman, Mansour H.

Published in:
Proceedings of the 5th Nordic Wind Power Conference

Publication date:
2009

Document Version
Publisher's PDF, also known as Version of record

[Link to publication from Aalborg University](#)

Citation for published version (APA):

Bak-Jensen, B., Kawady, T. A., & Abdel-Rahman, M. H. (2009). Coordination between Fault-Ride-Through Capability and Overcurrent Protection of DFIG Generators for Wind Farms. In *Proceedings of the 5th Nordic Wind Power Conference* Technical University of Denmark (DTU).

General rights

Copyright and moral rights for the publications made accessible in the public portal are retained by the authors and/or other copyright owners and it is a condition of accessing publications that users recognise and abide by the legal requirements associated with these rights.

- ? Users may download and print one copy of any publication from the public portal for the purpose of private study or research.
- ? You may not further distribute the material or use it for any profit-making activity or commercial gain
- ? You may freely distribute the URL identifying the publication in the public portal ?

Take down policy

If you believe that this document breaches copyright please contact us at vbn@aub.aau.dk providing details, and we will remove access to the work immediately and investigate your claim.

Coordination between Fault-Ride-Through Capability and Overcurrent Protection of DFIG Generators for Wind Farms

Birgitte Bak-Jensen, Tamer A. Kawady, *MIEEE*, Mansour H. Abdel-Rahman,

Abstract— Due to the increasing penetration of wind farms in power systems, stability issues arise strongly for power system operation. Doubly-Fed Induction Generators (DFIG) are characterized with some unique features during normal/abnormal operating conditions as compared with singly-fed ones. Fault ride-Through (FRT) mainly aims to delay a disconnecting of the DFIG units during grid faults for a possible time to restore the system stability if the fault is cleared within a permissible time. This strategy may, however, affect the performance of related protective elements during fault periods. In this paper, the Coordination between Fault Ride-Through Capability and Overcurrent Protection of DFIG Wind Generators in MV Networks is investigated. Simulation test cases using MATLAB-Simulink are implemented on a 345-MW wind farm in AL-Zaafarana, Egypt. The simulation results show the influence of FRT capability on protective relaying coordination in wind farms.

Index Wind farms Protection, Dynamic modeling, MATLAB-Simulink, Fuse.

I. INTRODUCTION

Owing to the rapid increase of the global population and their energy needs, traditional means to satisfy the burgeoning energy demands need careful reevaluation. Coupled with the uneven distribution of resources around the world, the importance of renewable resources of energy is obvious. Among these resources, wind electric conversion has emerged as the leader at the present time. The impressive growth in the utilization of wind energy has consequently spawned active research activities in a wide variety of technical fields. Moreover, the increasing penetration of wind energy into conventional power systems highlights several important issues such as reliability, security, stability, power quality, ... etc.

The essential benefits from a dedicated protection functions are to avoid possible local damage resulting from incident faults and minimize the impact of these abnormal conditions on the other sound parts of the network. This reduces the

associated negative impacts of the faults on the service continuity and the system stability. Consequently, it enhances the reliability and dependability of the overall grid performance. Wind farms still utilize surprisingly simple and none-integrated protection methodologies [1]. Also, research efforts regarding wind farm protection are still limited in the literatures. As reported by Bauscke et al. in [2], different levels of damage were recorded resulting occasionally from the drawbacks of the associated protection system.

Conventionally, wind turbines were separated from the grid following grid faults leading to loss of an undesirable portion of power generation. Hence, utilities nowadays require Fault Ride-Through (FRT) capability for grid-connected wind farms. FRT aims mainly to enable the wind farm to withstand severe voltage dips at the connection point resulting from the occurring grid faults. Hence, wind farm is required to remain grid-connected during grid faults for a certain time so that it can directly contribute with active power to the grid. This leads to support the overall system stability. This is nowadays essentially required by almost all known grid codes for modern variable speed DFIG [3]. DFIGs have nowadays the superiority for wind farms as compared with conventional IGs. This is mainly because these units are distinctive with different advantages including ability to control voltage and reactive power, low short circuit contribution and supporting the system stability. These grid codes were issued mainly to define the basic requirements of wind turbines during grid faults considering their operation modes and control strategies.

On the other hand, different problems arise for the associated generator/converter protection and control issues. During these voltage dips, the delivered active power to the grid by the farm is remarkably reduced. Consequently, the mechanical power exceeds the delivered active power resulting in increasing the rotor speed. Then, the control scheme of the DFIG variable-speed wind turbines embraces both the wind turbine control for preventing over-speeding of the wind turbine and the control and protection of the power converter during and after the grid faults [4].

Although the FRT enable the overall system to restore its stability without losing large amounts of power generations after fault clearing, these control strategies may influence the related protective elements. Relay miss-coordination or miss-operation may occur due to the resulting changes of fault current profile. The aim of this paper is to investigate the behavior of overcurrent protection used with wind generating units during the operation of the FRT procedure. These investiga-

This work was made possible by the EU UPWIND (Integrated Wind Turbine Design) project No 019945 under the SIXTH FRAMEWORK PROGRAMME PRIORITY 6. Sustainable development, global change and ecosystems. The authors acknowledge with thanks. Tamer.A. Kawady is with the Department of Electrical Engineering, Menoufiya University, Egypt (e-mail: t_kawady@ieee.org).

Mansour H. Abdel-Rahman (e-mail: mhar@iet.aau.dk)

Birgitte Bak-Jensen (e-mail: bbj@iet.aau.dk) both are with the Institute of Energy Technology, Aalborg University, Denmark

tions are carried out based on well prepared simulation examples. Among the known packages for dynamic simulation purposes MATLAB [7] was employed for developing a successful dynamic simulation of a wind farm that is used to carry out this study due to its modeling capabilities and superior development facilities. Results of a 345-MW wind farm in Egypt is considered as a simulation example for this study showing the influences of FRT capability on the conventional overcurrent protection used commonly in wind farms.

II. CONVENTIONAL PROTECTION SYSTEM FOR WIND FARMS

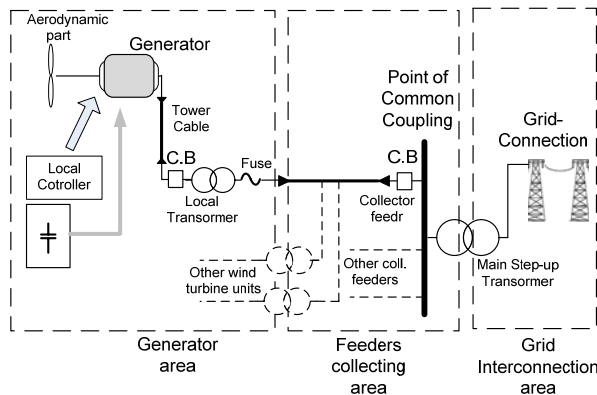

Fig. 1 Schematic of the conventional protection system

Fig. 1 shows a schematic of a typical wind farm consisting of (n) units of wind turbines. Nowadays, modern wind farms include 20 to 150 units with typical size from 0.5 MW to 3 MW wind turbine generators. Larger sizes up to 5 MW are recently available in the market, in which they were successfully installed in some European countries. The use of induction generators in wind farm installations is today a standard practice, due to its suitable characteristics for the wind turbines. The typical generator terminal voltage may range from 575 to 690 V with a frequency of 50 (or 60) Hz. The generator terminal voltage is stepped up to the Collector Bus system with typical voltage of 22 to 34.5 kV. The step up transformer is normally oil cooled, pad mounted unit located at the base of the wind turbine unit. Sometimes, the step up transformer is mounted in the turbine nacelle. These transformers are usually victims to remarkable vibrations due to the wind load hitting the wind turbine. Certain considerations should be applied for avoiding harmonic effects. The transformer tanks have vertical and horizontal reinforcements to reduce vibration and resonance. Also, the core/coil assembly will be highly clamped and secured in the tank, restricting any movement in any of the three dimensions. The typical wind farm collector system consists of a distribution substation collecting the output of the distributed wind turbine generators through the incoming feeders. Usually some reactive power compensation units are provided by a collection of switched capacitors. Finally, the collected power is transferred to the utility side via an interconnection step up transformer.

The wind farm protection system is usually divided into different protection zones including the wind farm area, wind farm collection system, wind farm interconnection system and the utility area. First, the induction generator protection is

typically accomplished via the generator controlling system covering some certain protection functions such as under/over voltage, under/over frequency, and generator winding temperature (RTDs). The generator control system does not contribute to the interconnecting system or the utility zone. The generator is protected against short circuits with its circuit breaker, which is practically dimensioned to 2-3 times the generator rated current. The generator step up transformer is usually protected with fuses dimensioned to 2-3 times its rated current. The collector feeder protection is simplified considering it as a radial distribution feeder using overcurrent protection (50/51). A basic challenge arises due to the distributed generators connected together to the radial feeder in determining the minimum faulty zone. That is in order to keep the remaining sound parts of the farm supplying the power. On the other hand, the protection of the wind farm substation collector bus and main power transformer consists of a multi-function numerical relay system including main transformer differential relay, transformer backup overcurrent relay, collector bus differential relay and breaker failure relay. Further details are available in the literatures [5]-[7]. It should be considered that, the wind farm interconnection would be applied to MV distribution network, HV system ... etc. Therefore, the coordination of utility relays and the wind farm will be quite different. Communication systems with dedicated SCADA are quite important for wind farm operation. Nowadays, the data from each wind generator control is transmitted via optic cables and spread to the main substation for general control and monitoring purposes. This provides an ideal situation for providing them with an integrated monitoring and control system.

III. PROBLEM IDENTIFICATION

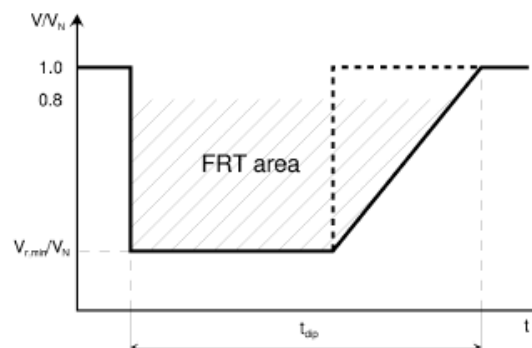

Fig. 2 FRT capability curve profile

1. Fault Ride-Through fundamentals for DFIGs

Historically grid codes allowed the wind turbines to be disconnected instantaneously with voltage sag below .8 per unit. In 2003, E.ON and VET (Germany) introduced the first FRT code requirements. Later, other international wind energy associations introduced their similar codes as well. Generally speaking, the grid codes required that grid connected wind turbines should withstand voltage dips on any or all phases in the transmission system as long as the voltage measured at the high-voltage terminals of the grid-connected transformer, or in other words at the common coupling point (CCP), remains above the predetermined level of the grid code [8]-[12]. Different benefits are expected to be gained with FRT capabilities

including enhancing the system stability and fast restoration of system service if the fault is cleared during the allowable time. These capabilities can be achieved by an adapted control strategy.

2. Crowbar system protection

The crowbar comprises of some certain thyristors that short-circuit the rotor winding and hence thereby limit the rotor voltage and provide an additional path for the fault current. When a disturbance is introduced, high currents are induced into the rotor circuitry from the stator side affecting the dc-link voltage as well. Then, the dc-link over-voltage protection will stop the rotor converter/inverter unit, meanwhile it turns on the crowbar control thyristor. Similarly, the crowbar can be triggered based on the occurring overcurrent through the rotor circuitry. The rotor is now connected to the crowbar and remains connected until the main circuit breaker disconnects the stator from the grid [13], [14]. After clearance of the fault the generator can be line-synchronized again and started in a normal operation mode.

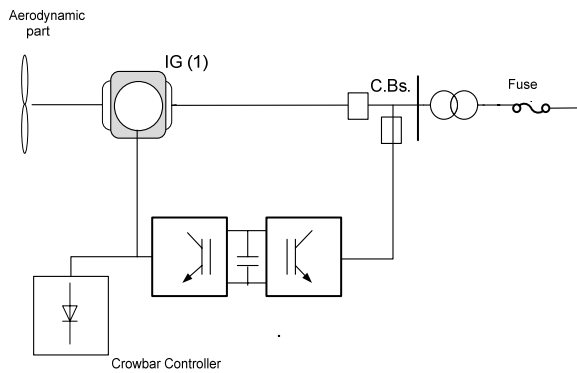

Fig. 3 Crowbar protection system for DFIG units

The core of the crowbar operation was described by Akhmatov, Xiang, Holdsworth, Ekanyaki and Niiranen as reported in [9] -[17]. Technically, two types of crowbar systems are known including passive and active ones. For passive ones, the crowbar consists of a diode bridge that rectifies the rotor phase currents and a single thyristor in series with a resistor R_{crow} . The thyristor is turned on when the DC link voltage U_{dc} reaches its maximum value or the rotor current reaches its limit value. Simultaneously, the rotor of the DFIG is disconnected from the rotor-side frequency converter and connected to the crowbar. The rotor remains connected to the crowbar until the main circuit breaker disconnects the stator from the network. When the grid fault is cleared, the rotor-side converter is restarted, and after synchronization, the stator of the DFIG is connected to the network.

In contrast to a conventional passive crowbar, the active crowbar is fully controllable by means of a semiconductor switch. This type of crowbar is able to cut the short-circuit rotor current whenever needed and thus the DFIG wind turbine is able to ride through a network disturbance. If either the rotor current or dc link voltage levels exceed their limits, the IGBTs of the rotor-side inverter are blocked and the active crowbar is turned on. The crowbar resistor voltage and dc link voltage are monitored during the operation of the crowbar.

When both these voltages are low enough, the crowbar is turned off. After a short delay for the decay of the rotor currents, the rotor-side inverter is restarted and the reactive power is ramped up in order to support the grid.

3. FRT behavior during disturbances

Fig. 4 shows different fault locations occurring on either the wind farm MV distribution network or the HV transmission system connecting the farm to the grid. These fault positions are designated with (A), (B), (C) and (D) respectively. Ideally, successful FRT operation is restricted to those faults that occur outside the wind farm in order to support the system stability. For those faults occurring inside the farm, the FRT scheme should not operate in order to enable the associated protection system to respond correctly. Referring to Fig. 3, solid three phase faults at positions (A) and (B) are normally characterized with larger voltage dips (down to 10% of the nominal voltage) which may be localized below the FRT characteristic edge. Hence, these faults may not trigger the FRT mechanism to operate. On the other hand, other external faults such as those ones at positions (C) and (D) are characterized with relatively smaller voltage dips (about 30% of the nominal voltage). Then, the FRT mechanism should operate correctly.

Since, the core for the crowbar mechanism depends mainly on the occurring rotor overcurrent to start, the aforementioned behavior of the FRT is expected to function properly for solid three phase faults as described earlier. This however, can not be guaranteed for non-solid faults or for unbalanced ones.

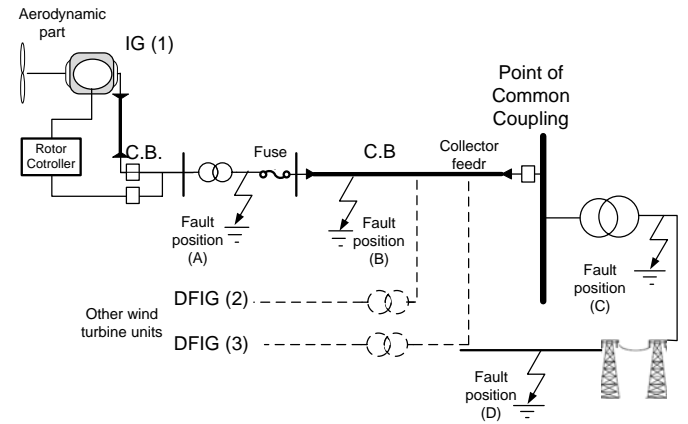

Fig. 4 Fault positions during faults for wind generating unit

IV. DEVELOPMENT OF THE SYSTEM MODELING

Modeling of DFIGs is well described in the literatures [15]-[17]. A 345-MW wind farm was recently established in Al-Zafarana (220 south east of Cairo, Egypt) and connected to the Egyptian 220kV grid. This area is distinctive with different features such as an average annual wind speed of 9.5 m/s, and its excellent geographical and environmental features. The farm was structured through seven stages of 30, 33, 30, 47, 80 and 85, 120 MW respectively as described in Fig. 5(a). Except the latter two stages, other stages are with fixed speed and variable pitch operation. The fifth stage of the farm was selected as a simulation example in the paper. It consists of 100 wind turbines (with a 850 KW DFIG units for each turbine) providing a total power of 85MW. The DFIGs were dis-

tributed at seven feeders as illustrated in Fig. (b). Each wind turbine is connected to a 690V:22 KV local step-up transformer. The collected power are then fed to the 220 kV network through three 75 MVA, 22/220 kV step-up transformers.

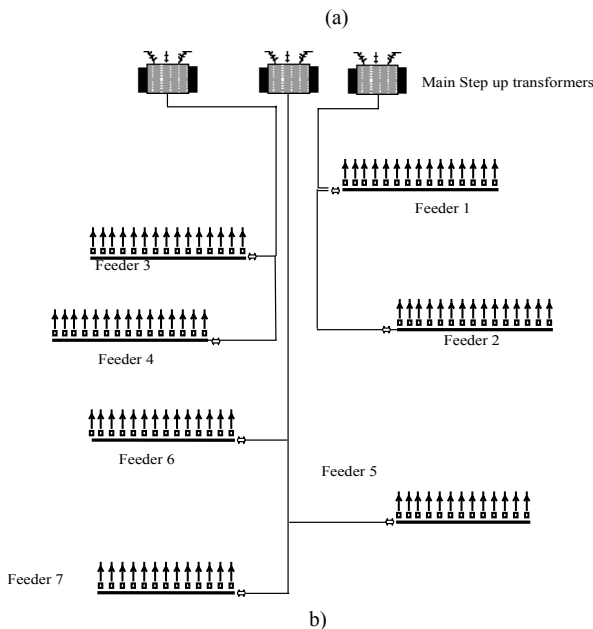
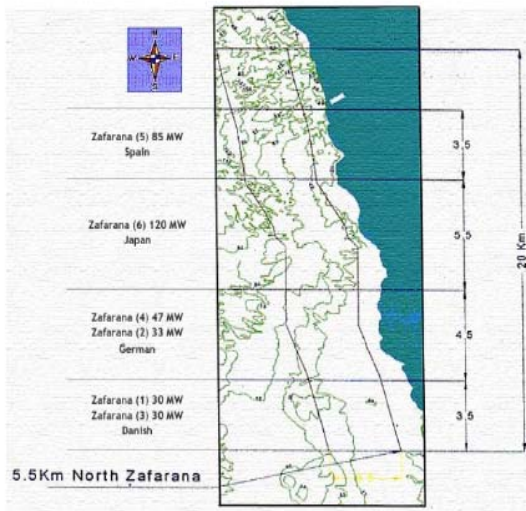

Fig. 5 Description of the fifth stage of Al-zafarana Farm
(a) Geographical distribution of Al-Zafarana farm
(b) Schematic of the fifth stage of Al-Zafarana Farm

The turbine operation was characterized with the wind speed, the generator speed and its individual pitch control, where its nominal wind speed was assigned to 9.5 m/sec “the annual average wind speed in its corresponding location” and the “cut-in” wind speed was assigned to be 4.5 m/sec. Each wind turbine was equipped with its induction generator model based on the asynchronous machine built-in model in MATLAB [18]. The operation of the crowbar was modeled by deactivating the converters upon the detection of rotor current magnitude above the current protection limit and short-circuiting the generator rotor.

Fig. 6 shows the detailed schematic diagram of each wind unit constructed with the built-in wind turbine model in MATLAB. The relatively large number of wind turbine units, in which each of them was constructed with different individual items “Turbine, generator, local transformer, feeding cable, ...” increased remarkably the corresponding source of code. This is characterized with a huge operation time (around 305 min. for each single running on a 3.2 GHz, 2GB-RAM machine). This resulted in an impractical testing profile for those simulation purposes that are characterized with huge amounts of simulation cases. Moreover, the aforementioned problem is significantly exaggerated for larger systems. Therefore, the need for reducing the overall wind farm model is obvious.

On the other hand, the reduced model should be conditioned with the following restrictions:

- Model Accuracy for each individual power system element should be kept in its higher level
- The essential concepts for distributed generation must be satisfied.
- Equivalence of currents for each individual unit as well as overall farm currents for both detailed and reduced model should be realized
- Equivalence of the generated power for each individual unit as well as for the overall farm for both detailed and reduced model should be realized.
- Total power losses (due to connecting cables) should be considered.

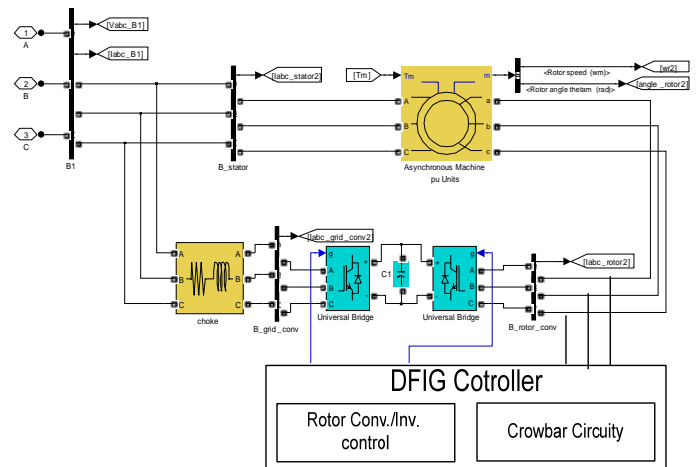

Fig. 6 Simulink-based diagram of a single unit diagram

Fig. 7 illustrates the proposed reduced model for the fifth stage of Al-Zafarana wind farm. The first six collecting feeders were lumped with their power equivalency with total lumped equivalent generators for each feeder respectively. For the latter collecting feeder, among its wind turbine generators, 10 generators were represented with their equivalent lumped generator, whereas the rest ones (the first, second and last units) were represented individually for keeping the distributed generation concept. For those lumped units, cable lengths were considered for keeping the total power losses equal to those resulted with the corresponding detailed model. The re-

sponse of the reduced model was validated compared with the corresponding detailed one via different simulation examples for both faulty and non-faulty operating conditions. Details for the proposed modeling methodology were fully addressed in [7].

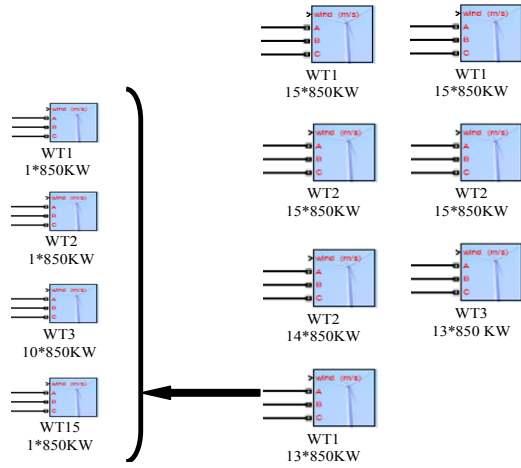

Fig. 7 Schematic of the reduced wind farm model.

V. SIMULATION RESULTS

Depending on the developed reduced model in the preceding section, the behavior of the DFIG units in conjunction with the related FRT mechanism was thoroughly investigated under various faulty and non-faulty operating conditions. These cases were applied on the seventh collecting feeder as described in Fig. 4. Four different fault locations were considered: beyond the local step-up transformer (position A), along the connecting cable (position B), beyond the grid-connecting transformer (position C) and along the HV transmission line (position D). For each case, voltage and current quantities for both stator and rotor circuitries were recorded as described in the following sub-sections.

A. Grid faults

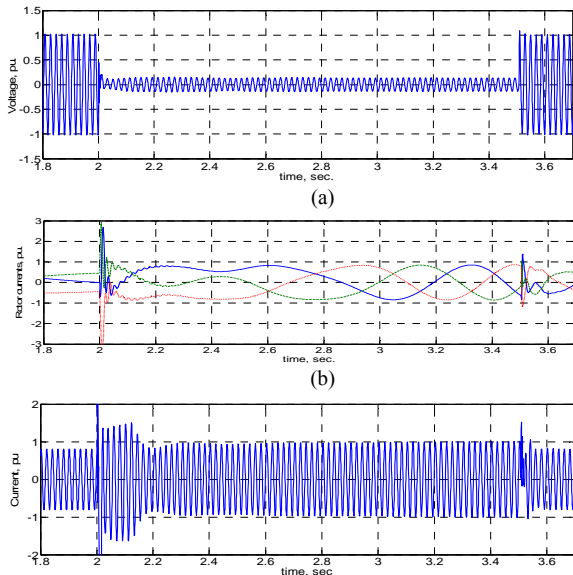

Fig. 8 Simulation response due to a solid 3-phase grid-fault at position (c) without crowbar initialization .

- (a) Stator phase voltage, pu.
- (b) Rotor phase currents, pu.
- (c) Stator phase current, pu.

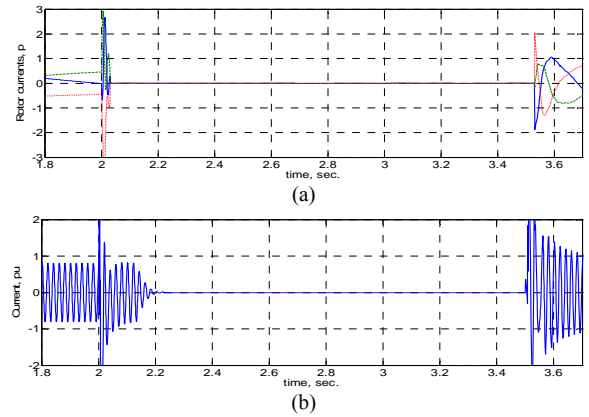

Fig. 9 Simulation response due to a solid 3-phase grid-fault at position (c) with crowbar initialization.

- (a) Rotor phase current, pu.
- (b) Stator phase current, pu.

During grid faults, the occurred faults resulted in a sufficient drop of phase voltage so that the associated crowbar mechanism was initiated to protect the rotor windings from the excessive fault current. As illustrated from Fig. 8, both rotor and stator windings suffered from the increased currents resulted from a solid 3-phase grid fault occurring at position (C). On the other hand, initiated crowbar mechanism resulted in shorting the rotor winding rapidly after the fault inception after 2 seconds as well as deactivating the rotor controller as remarked from Fig. 9, meanwhile the DFIG react similarly to the conventional single infeed machines. Rotor currents were decreased to zero avoiding the possible winding damage, whereas the stator currents were decreased to zero due to the loss of reactive power compensation. This was fully addressed for three phase faults for single infeed machines in [7]. When the fault was cleared at 3.5 second, the DFIG was restarted again.

B. Solid Wind farm faults

In order investigate the behavior of the DFIG equipped with crowbar mechanism, a solid 3-phase fault was applied before the local transformer at position (B). As illustrated from Fig. 10, the resulting low voltage condition at the generator terminals inhibited the crowbar operation. This was owing to the relatively larger voltage drop located lower than the FRT edge from the shown characteristics in Fig. 2.

Similarly, the DFIG response for a 2-phase solid fault at the same position beyond the local step-up transformer at position (B) was investigated as shown in Fig. 11. As remarked from the results, the occurred voltage drop initiated the crowbar mechanism. As noted from Fig. 11(c), the resulted stator fault current was kept below the predetermined setting of the utilized fuse element selected typically from 2 to 3 times the rated current. Repeating the same fault with deactivating the crowbar

mechanism is illustrated in Fig. 12(a) and (b), in which the fault resulted in a relatively larger fault current as noted from the associated Discrete Fourier Transform (DFT)-based peak detector of the fault current. These aforementioned results raise the effects of the FRT mechanism on the performance of employed overcurrent protection with DFIG machines equipped with FRT mechanisms.

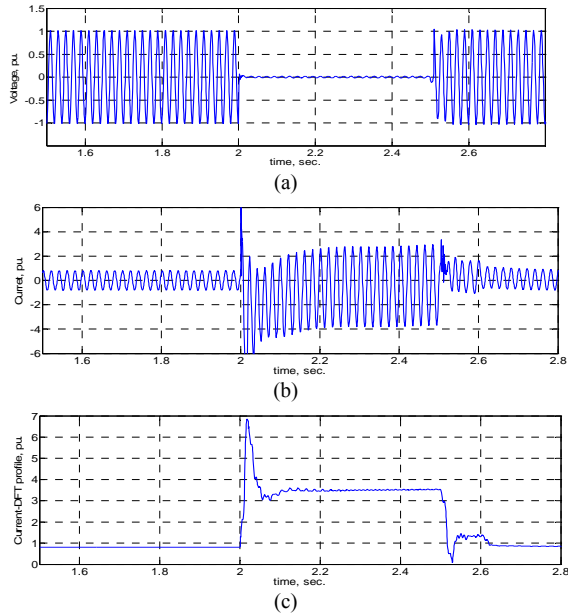

Fig. 10 Simulation response due to a solid 3-phase fault at position (B) with crowbar initialization.

- (a) Stator phase voltage, pu.
- (b) Stator phase current, pu.
- (c) Stator phase current peak profile with DFT

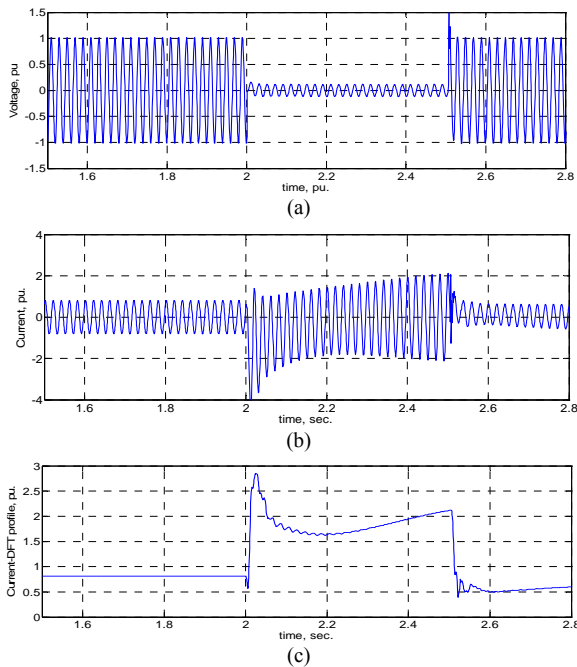

Fig. 11 Simulation response due to a solid 2-phase fault at position (B) with crowbar initialization.

- (a) Stator phase voltage, pu.
- (a) Stator phase current, pu.
- (b) Stator phase current peak profile with DFT

C. Non-solid wind farm faults

At non-solid faults usually the fault current decreases due to an increased fault resistance. These faults should be considered for evaluating the behavior of the DFIG machines equipped with FRT mechanisms. When a fault resistance is inserted into the fault current path, the decrease of the fault current is accomplished with a decrease of the occurring voltage drop at the generator terminals. Consequently, the FRT mechanism may incorrectly be initiated for faults occurring inside the wind farm. This results in inhibiting the operation of the related overcurrent protection due to the reduced fault current. This is illustrated in Fig. 13 for a 3-phase fault occurring at position (A) through a 2Ω fault resistance with utilizing crowbar operation. Whereas the DFIG response, for the same fault condition, with deactivating the crowbar mechanism is shown in Fig. 14. As concluded from both results, the crowbar operation reduced the fault current rapidly, whereas the fault current was kept at a remarkable level with the FRT operation. Hence, the impact of the FRT operation on the performance of overcurrent relays for such situations is obvious.

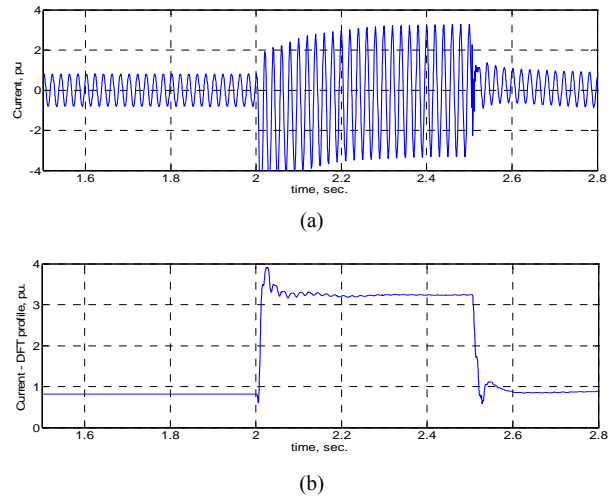

Fig. 12 Simulation response due to a solid 2-phase fault at position (B) without crowbar initialization.

- (a) Stator phase current, pu.
- (b) Stator phase current peak profile with DFT

VI. CONCLUSIONS

DFIG generators represent nowadays the most common generator type for wind farms using either onshore or offshore turbines. Owing to the increasing penetration of wind farms into power system grids, FRT capabilities is recently required by all known common grid codes. Common FRT strategies for DFIGs are usually performed with shorting the rotor winding of the faulted DFIG and deactivating the rotor converter immediately after detecting the occurring fault. The DFIG behaves, therefore, exactly as conventional SFIGs during the fault period. This results in lower levels of fault currents as compared with continuous DFIG operation during the fault. This consequently affects the behavior of conventional overcurrent protection elements against network faults occurring

into the local connecting circuitry of the wind farm. Fault resistance in conjunction with FRT strategies, even with small values, shows a significant effect perturbing the performance of the overcurrent protection as well. The results corroborate the need for new or modified coordination rules for overcurrent elements incorporated with DFIGs and FRT capability tools.

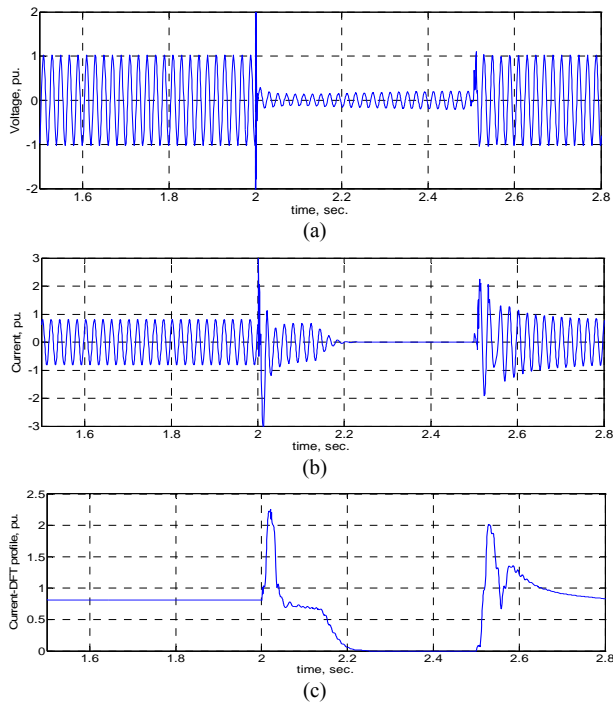

Fig. 13 Simulation response due to a 3-phase fault at position (A) with crowbar initialization and fault resistance of 2Ω .

- (a) Stator phase voltage, pu.
- (b) Stator phase current, pu.
- (c) Stator phase current peak profile with DFT

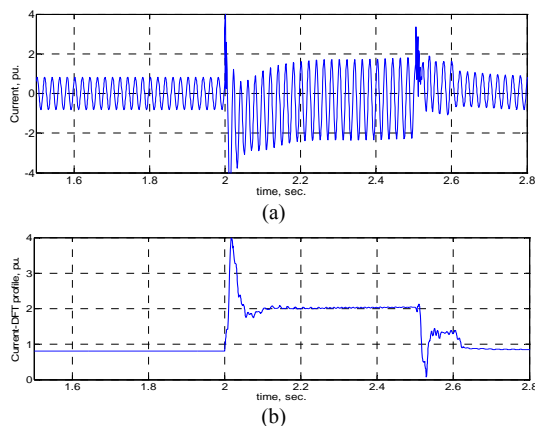

Fig. 14 Simulation response due to a 3-phase fault at position (A) without crowbar initialization and fault resistance of 2Ω .

- (a) Stator phase current, pu.
- (b) Stator phase current peak profile with DFT

VII. REFERENCES

[1] D. Hornak, N. Chau, "Green power - wind generated protection and control considerations", Protective Relay Engineers, 2004 57th Annual Conference for 30 Mar-1 Apr 2004, pp. 110 – 131.

[2] Stefan Bauschke, Clemens Obkircher, Georg Achleitner, Lothar Fickert and Manfred Sakulin, "Improved Protection system for electrical components in wind energy plants", 15th International Conference on Power System Protection, PSP '2006, Bled-Slovenia, 6-8 Sept. 2006.

[3] I. Erlich, Member, IEEE, W. Winter, A. Dittrich, "Advanced Grid Requirements for the Integration of Wind Turbines into the German Transmission System", IEEE General Meeting, GM2006.

[4] I. Erlich, H. Wrede, and C. Feltes, "Dynamic Behavior of DFIG-Based Wind Turbines during Grid Faults", Power Conversion Conference - Nagoya, 2007. PCC '07, 2-5 April 2007 pp. 1195 – 1200.

[5] S. Haslam, P. Crossley and N. Jenkins, "Design and evaluation of a wind farm protection relay", Generation, Transmission and Distribution, IEE Proceedings, Volume 146, Issue 1, Jan. 1999, pp. 37 – 44.

[6] R. Fuchs, "Protection schemes for decentralized power generation", Developments in Power System Protection, 2004. Eighth IEE International, 5-8 April 2004, Vol. 1, pp. 323 – 326.

[7] Tamer A. Kawady, Naema Mansour, Abdel-Maksoud Talaab, "Performance Evaluation of Conventional Protection Systems for Wind Farms" IEEE/PES General Meeting, GM-2008, Pittsburg, 20-24 July, 2008.

[8] Andreas Dittrich Alexander Stoev, "Comparison of fault ride-through strategies for wind turbines with DFIM generators", Power Electronics and Applications, 2005 European Conference on, Dresden, Germany.

[9] V. Akhmatov, "Analysis of Dynamic Behaviour of Electric Power System with Large Amount of Wind Power", PhD Thesis, Electric Power Engineering, Orsted DTU Technical University of Denmark, April 2003, Denmark.

[10] Niiranen, J. 2004. "Voltage Dip Ride Through of Doubly-Fed Generator Equipped with Active Crowbar", Nordic Wind Power Conference, 1-2 March 2004, Chalmers University of Technology, Göteborg, Sweden.

[11] Niiranen, J. 2005. "Experiences on Voltage Dip Ride through Factory Testing of Synchronous and Doubly Fed Generator Drives", Proceedings of 11th European Conference on Power Electronics and Applications. Dresden, Germany, 11-14 September 2005.

[12] Anca D. Hansen and Gabriele Michalke, "Fault ride-through capability of DFIG wind turbines", Renewable Energy, Elsevier, Vol. 32 (2007), pp. 1594-1610

[13] Niiranen, J. 2006. "About the Active and Reactive Power Measurements in Unsymmetrical Voltage Dip Ride Through Testing", Nordic Wind Power Conference, 22-23 May 2006, Espoo, Finland.

[14] Xiang, D., Ran, L., Tavner, P.J., Bumby, J.R. 2004. "Control of a Doubly-fed Induction Generator to Ride-through a Grid Fault", Proceedings of ICEM 2004, Cracow, Poland, 5-8 September 2004.

[15] Petersson, A., Thiringer, T., Harnefors, L., Petru, T. 2005. "Modeling and Experimental Verification of Grid Interaction of a DFIG Wind Turbine", IEEE Transactions on Energy Conversion, Vol. 20, Issue 4, Dec. 2005, pp. 878-886.

[16] Ekanayake, J.B., Holdsworth, L., Wu, X.G., Jenkins, N. 2003b. "Dynamic Modeling of Doubly Fed Induction Generator Wind Turbines", IEEE Transaction on Power Systems, Vol. 18, Issue 2, May 2003, pp. 803-809.

[17] Holdsworth, L., Wu, X.G., Ekanayake, J.B., Jenkins, N., 2003a. "Comparison of Fixed Speed and Doubly Fed Induction Wind Turbines during Power System Disturbances", IEE Proceedings - Generation, Transmission and Distribution, Vol. 150, No. 3, May 2003, pp. 343-352.

[18] The MathWorks Inc., MATLAB, Ver. 7.2, 2006, "http://www.mathworks.com/".

VIII. BIOGRAPHIES



Birgitte Bak-Jensen (M'88) received her M.Sc. degree in Electrical Engineering in 1986 and a Ph.D. degree in "Modeling of High Voltage Components" in 1992, both degrees from Institute of Energy Technology, Aalborg University, Denmark.

From 1986-1988, she was with Electrolux Elmotor A/S, Aalborg, Denmark as an Electrical Design Engineer. She is an Associate Professor in the Institute of Energy Technology, Aalborg University, where she has worked since August 1988. Her fields of interest are modeling and diagnosis of electrical components, power quality and stability in power systems. During the last years, integration of dispersed generation to the network grid has become one of her main fields, where she has participated in many projects concerning wind turbines and their connection to the grid.



Mansour H. Abdel-Rahman (M'79) was born in Egypt in 1947. He received the B.Sc. and M.Sc. degrees in electrical engineering from Cairo University in 1970 and 1975, respectively, and the Ph.D. degree in electrical engineering from the University of Manchester Institute of Science and Technology (UMIST), U.K., in 1979. He has been a Full Professor at the University of El-Mansoura, Egypt, since 1987. He spent visiting assignments, teaching and researching, at the University of Toronto, Canada, University of Windsor, Canada,

the University of Cambridge, U.K., where he was a Fellow of Churchill College, University of Western Australia, Australia, Doshisha University, Japan, Helsinki University of Technology, Finland, University of Iceland, University of Aalborg, Denmark, Jordan University, Jordan, and Kuwait University, Kuwait. His research interests include electromagnetic transients in power system networks and machines, steady-state and dynamic analysis of power systems, and the application of artificial intelligence in power systems.

Dr. Abdel-Rahman received the John Madsen Medal for the best paper submitted to the Institute of Engineers, Australia, in 1989, the IEEE Industry Application Society First Prize Paper in 1988, and the IEEE Industrial and Committee Prize Paper in 1987.



Tamer A. Kawady (MIEEE'02) was born in Shebin El-kom, Egypt on Sept. 30, 1972. He received his B.Sc. (honors) and M.Sc. degrees in Electrical Engineering, Menoufiya University, Egypt, Ph.D. degree (excellent) from Technical University Darmstadt, Germany in 1995, 1999 and 2005 respectively. Dr. Kawady is currently an assistant professor at Menoufiya University, Egypt since April 2005. Dr. Kawady has tens of published journal and conference papers and he is now a reviewer for various IEEE

and IET journals. His interests are in digital protection, Power system simulation using the Electromagnetic Transient Program (ETP) and Artificial Intelligence applications to power system protection.