



Aalborg Universitet

AALBORG UNIVERSITY
DENMARK

Harmonic models of a back-to-back converter in large offshore wind farms compared with measurement data

Kocewiak, Lukasz Hubert; Hjerrild, Jesper; Bak, Claus Leth

Published in:
Proceedings of Nordic Wind Power Conference 2009

Publication date:
2009

Document Version
Publisher's PDF, also known as Version of record

[Link to publication from Aalborg University](#)

Citation for published version (APA):
Kocewiak, L. H., Hjerrild, J., & Bak, C. L. (2009). Harmonic models of a back-to-back converter in large offshore wind farms compared with measurement data. In *Proceedings of Nordic Wind Power Conference 2009* Technical University of Denmark (DTU).

General rights

Copyright and moral rights for the publications made accessible in the public portal are retained by the authors and/or other copyright owners and it is a condition of accessing publications that users recognise and abide by the legal requirements associated with these rights.

- ? Users may download and print one copy of any publication from the public portal for the purpose of private study or research.
- ? You may not further distribute the material or use it for any profit-making activity or commercial gain
- ? You may freely distribute the URL identifying the publication in the public portal ?

Take down policy

If you believe that this document breaches copyright please contact us at vbn@aub.aau.dk providing details, and we will remove access to the work immediately and investigate your claim.

Harmonic models of a back-to-back converter in large offshore wind farms compared with measurement data

Łukasz Hubert Kocewiak, Jesper Hjerrild, Claus Leth Bak

Abstract—The offshore wind farm with installed back-to-back power converter in wind turbines is studied. As an example the Burbo Bank offshore wind farm with Siemens Wind Power wind turbines is taken into consideration. The wind farm is simulated in DIGSILENT Power Factory software in order to determine and assess harmonic emission in the point of common coupling.

Different modelling methods of power electronic devices installed in wind turbines are presented. Harmonic load flow analysis and impedance frequency characteristics calculation are conducted to present differences between the models.

Simulation results are compared with measurement data from the Burbo Bank offshore wind farm. The delimitations of both power converter models with referent to harmonic analysis are shown in this paper.

Index Terms—back-to-back converter, harmonic analysis, measurement data processing, offshore wind farm, wind power, wind turbine.

I. INTRODUCTION

THE number of variable speed wind turbines (WT) with advanced power electronic converters in the MW range used in large offshore wind farms (OWF) is rapidly increasing [1, 25]. More and more WTs manufacturers such as General Electric (GE) Energy, Siemens Wind Power, Vestas Wind Systems or Gamesa use back-to-back converters in their flagship products. Nowadays OWFs are connected through a widespread MV submarine cable network and connected to the transmission system by long HV cables. This represents new challenges to the industry in relation to understanding the nature, propagation and effects of harmonics [8, 12].

A. Wind Power Market

In recent years, power systems in the whole world have experienced a significant increase in dispersed generation units (DGUs), and especially wind energy penetration. Presently, the trend is for planning large WFs with a

capacity of hundreds of MVA. This large-scale utilization of wind energy has caused an increasing concern about its influence on the power quality of the power system.

Commonly applied in WTs power electronic devices, transferring power from the generator to the grid, are able to meet with the most demanding grid requirements. The latest achievements in semiconductor technology and control methods of WT converters contributes to improve power quality obtained from modern wind power plants, enhanced voltage stability [6, 14]. Reduced transmission losses and reliability improvement are the most important virtues of dispersed power generation sources. Those advantages create bright future for the wind power industry.

B. Back to Back Converter

The use of DGUs with voltage source converter (VSC)-based interfaces for controlling the voltage (and for providing other improvements) is commonly applied in modern large OWFs. Large DGUs such as large OWFs are able to operate in a constant power factor mode and allow constant voltage mode operation [3]. This statement however seems to refer to rather large units what introduces legitimacy of offshore wind power development.



Fig. 1 Siemens SWT-3.6-107 wind turbine installed in an offshore wind farm (powergeneration.siemens.com).

The performance of WTs is a critical issue in light of increasingly stringent grid requirements [15]. These days, modern WFs provide a sophisticated set of grid code friendly benefits similar to conventional power plants. This is mainly back-to-back power converter merit.

This work is made as part of an Industrial Ph.D. project entitled “Harmonics in Large Offshore Wind Farms” supported by the Danish Ministry of Science, Technology and Innovation, project number 08-044839.

Ł. H. Kocewiak, J. Hjerrild, are with DONG Energy, Denmark (e-mail: lukko@dongenergy.dk, jeshj@dongenergy.dk).

C. L. Bak is with the Institute of Energy Technology, Aalborg University, Denmark (e-mail: clb@iet.aau.dk).

II. HARMONIC ANALYSIS IN OFFSHORE WIND FARMS

Non-linear characteristics of WF equipment (i.e. transformers) produce harmonics. A transformer operated at higher flux density (i.e. during an overvoltage) will operate in the saturation region making the exciting current a non-sinusoidal waveform containing the fundamental and odd harmonics [2]. This is the important reason of background harmonic existence in the WF point of common coupling (PCC).

The objective of power electronics equipment installed in WTs is to control and to condition the electric power (i.e. voltages and currents). Power electronics use semiconductor non-linear switching devices (i.e. diodes, thyristors and transistors). During normal operation they produce non-sinusoidal periodic voltages and currents, thereby producing harmonics and characteristic for power converters inter-harmonics [11].

Power electronic devices are widely used in WTs nowadays. They prove benefits such as controlling the frequency of the generator and thereby operating the wind turbine in variable speed, which leads to higher efficiency, reduced loads on the gear box and drive train [29]. The use of power electronics opens the possibility of direct drive wind turbines what has found an application in Enercon and Siemens Wind Power projects [30]. It also allows the control of active and reactive power flow and reduces flickers generated from the WT.

Non-harmonic distortion (inter-harmonics and non-periodic distortion) is much harder to quantify through suitable parameters and it is regularly neglected. For this purpose classical harmonic analysis (i.e. harmonic power flow) becomes insufficient [4]. Another reason for neglecting non-harmonic distortion is that harmonic distortion dominates in most cases. Nowadays, where power electronic converter application in OWFs is significant the extension of harmonic analysis becomes needed.

When the waveform is non-sinusoidal but periodic with a period of one cycle of the power system frequency, current and voltage waveforms can be decomposed into a sum of harmonic components. For the voltage this can be mathematically expressed as

$$v(t) = V_0 + \sum_{h=1}^H V_h \sqrt{2} \cos(h\omega t - \gamma_h)$$

With $\omega = 2\pi f_0$ and f_0 the fundamental frequency or power system frequency: $f_0 = 1/T$ with T the (fundamental) period of the signal. In the same way, the current waveform can be expressed. The phase angle of the fundamental component of the voltage γ_1 can be set to zero without loss of generality [5].

A. Analysed System Configuration

In this paper the Burbo Bank offshore wind farm (BBOWF) [26] is taken into consideration as an example, where measuring systems were installed and used for simultaneous measurement at different locations within the wind farm.

The BBOWF is located in the shallow waters (2 to 8 m) of the Burbo Flats in Liverpool Bay at the entrance to the River Mersey, approximately 6.4km (4.0 miles) from the Sefton coastline and 7.2km (4.5 miles) from North Wirral, covering an area of 10 km². It comprises 25 wind turbines accounting for a total installed capacity of 90 MW.

The 25 wind turbines in BBOWF are Siemens SWT-3.6-107 turbines with rated power of 3.6 MW, 107 m rotor diameter and 83.5 m hub height. It cuts-in at 3-5 ms⁻¹ increasing power output linearly until rated wind speed at 13-14 ms⁻¹ where the power is kept constant until cut-out at 25 ms⁻¹. The power curve of SWT-3.6-107 WT is presented in Fig. 2 [26]. It is a variable speed pitch controlled wind turbine, equipped with an asynchronous generator (WRIG) and full scale converter. The full scale converter performs reactive power compensation providing a smoother connection to the grid.

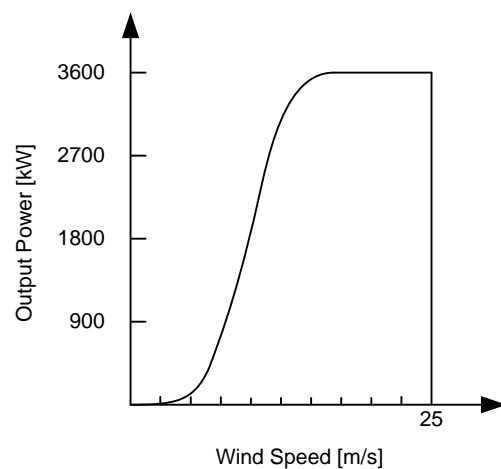

Fig. 2 Siemens Wind Power SWT-3.6-107 wind turbine calculated power curve.

The SWT-3.6-107 wind turbine is the latest model in the product range [6]. It is suitable for offshore applications and for onshore WFs. The rotor of the SWT-3.6-107 turbine is a three blade cantilevered construction, mounted upwind of the tower. The SWT-3.6-107 turbine is fitted with power electronic system that is compliant with even very demanding grid codes. The system has low voltage fault ride-through (LVRT) capability for all normal faults. It allows generator operation at variable speed, frequency and voltage while supplying power at constant frequency and voltage to the MV transformer.

The collection submarine cables connect the wind turbines to each other and to the submarine export cables, which in turn connects the wind farm to the onshore substation in Wallasey (34/132 kV) [9].

Offshore submarine power cables, unlike land cables, have complicated structures, having many concentric layers of different materials. This has a significant contribution to the overall cable impedance, what consequently affects the level of voltage and current waveform distortion and amplification due to possible resonances. This feature increases the complexity of analysis and modelling process of OWFs [7, 8].

The BBOWF is connected to SP Manweb's Network which is designed to operate substations in interconnected groups with standard transformer and cable sizes. The 132 kV and 33 kV networks comprise sections of underground cable or overhead lines or combinations of each. The BBOWF is connected to the 132 kV Wallasey Circuit 1. The cables and overhead lines in the network can create harmonic resonances dependent on the system configuration characterised by the system impedance. To predict this behaviour the whole external network at the 132 kV level has been modelled.

It is difficult to identify the external network configuration and load basis of measurement data. The network model configuration for simulation purpose has been chosen based on load profiles from ScottishPower Long Term Development Statement [9]. Few cases have been studied.

B. Measurement System and Accuracy

The measurement campaign in BBOWF took place from the end of November to the beginning of December 2007.

The measurements were carried out with a PC equipped with National Instruments data acquisition card, running by a programme developed in LabVIEW programming environment. Voltage and currents were sampled at 44.1 kHz, using NI PCI-4472 8-Channel Dynamic Acquisition (DAQ) Board. Wind speed and digital signals were sampled at 5 Hz with NI PCI-6052E DAQ card. The dynamic signal acquisition board has analog filter to remove any signal components beyond the range of the analog to digital converters (ADCs). To prevent high-frequency components, above half programmed sampling rate, from affecting the measured spectrum, an anti-aliasing filter is used. The anti-aliasing filter is an analog low-pass filter that is placed before the analog-digital (A/D) conversion. The described measurement setup is shown in Fig. 3 [27].

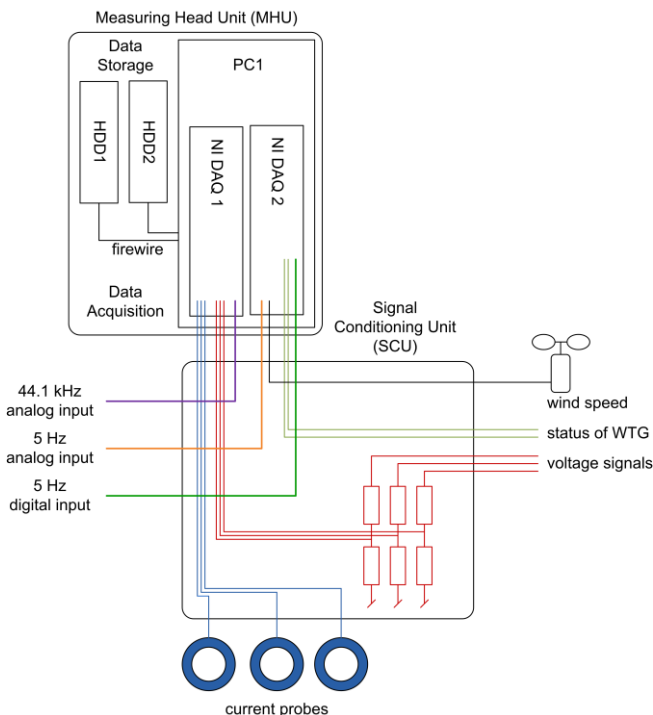

Fig. 3 DELTA powerLAB measuring system used in measurement campaign in Burbo Bank offshore wind farm.

Analysing the sampled voltage or current waveforms offers quantitative descriptions of power quality, such as the dominant harmonic components and their associated magnitudes. If the measurement data (or block of the data) are stationary, frequency-domain decomposition of the data is often desirable. A standard and commonly preferred method is the discrete Fourier transforms (DFT) or its fast algorithm, the fast Fourier transform (FFT) [4].

The harmonic voltages of OWFs normally result from the combination of emitted harmonic currents produced by non-linear power converter devices and non-linear passive components of the WF. Power converters are generally not fluctuating with significant correlation. Furthermore, quasi-stationary loads are also connected to the power system. Therefore, fast fluctuating harmonic voltage levels with a high fluctuation magnitude are an exception and seldom occur in the OWF [25].

However, strictly stationary signals do not exist in real-life WFs and power systems. Both small and large statistical changes occur in the electrical signal parameters. The presence of small and relatively slow statistical changes is addressed through so-called block-based methods [22, 23]. The signal is assumed stationary over a short duration of time (or window), a so-called block of data. The signal features are estimated over this window. The size of the window is not arbitrary defined and should be adjusted basis of experience and measurement data analysis [13, 21].

Note that it can be difficult in some occasions to judge whether a signal is stationary or non-stationary. To mathematically prove the stationarity requires the knowledge of the probability density function (PDF) of the signal and is therefore not a straightforward task.

C. Simulation Model

For simulation purposes, two power converter models have been used. Harmonic current and voltage sources with harmonic levels defined as look-up tables have been applied during analysis process.

The current source model has its limitations in that the load current is in reality not independent of the voltage. There is possibility to linearise the voltage dependence around an operational point by representing the load by its Norton equivalent (current source in parallel with source impedance). But the way how to determine the impedance is not straightforward. This neglects a lot of dependencies between power converter internal control working in closed loop and the whole system and may not give any better results than the pure current source model [2].

The traditional way of representing a nonlinear load in a harmonic penetration study is as a harmonic current source. The underlying assumption is that the harmonic current spectrum is not too much affected by the system voltage (or by its fundamental or by its distortion). For the traditional sources of waveform distortion such as HVDC links, this is a very acceptable model.

Let us consider the basic model of the grid converter as a part of back-to-back converter. Normally such kind of devices has a broad application in modern WTs. The grid-side converter with a large capacitor can be recognised as a DC voltage source, seen from the AC side of the converter.

This model is shown in Fig. 4. There are two switches for each phase. Each switch connects the DC voltage source to the AC network. The resulting current is due to the difference between the voltage of AC side (typically distorted) and the DC voltage. Depending on which of the switches is closed the two DC voltage sources of the same magnitude but opposite polarity can be recognised (appropriate for two level voltage source converter).

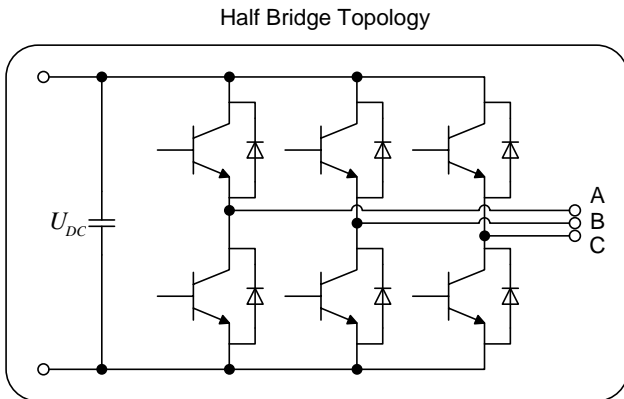

Fig. 4 Simplified diagram of two level and three phase voltage source converter.

During the conduction period the VSC can be represented as a voltage source. However, this does not yet justify the use of harmonic voltage sources for harmonic penetration studies. A serious argument against it is that the voltage outside the conduction period is not defined by the source. Outside the conduction period the current is zero, so that a current source model (with zero current) would be more appropriate. In the time domain modelling a voltage source model would be possible, but not in frequency domain studies. As the voltage is not defined during the whole cycle, it is not possible to determine the spectrum of the voltage waveform, and thus it is not possible to determine the harmonic voltage sources needed for the penetration studies [20].

The widespread MV submarine cable network connects 25 SWT-3.6-107 wind turbines to each other and to the HV submarine and land cables, which connect the WF to the onshore substation in Wallasey (34/132 kV). All land and submarine cables have been modelled as long-lines with skin effect approximated as a square-root function against harmonic order.

Other OWF components are simulated basis of already implemented models in the simulation software without including any frequency dependent characteristics [10].

D. Resonance phenomena

The current source model for distorting devices in WFs can also be used to explain a phenomenon called harmonic resonance. Due to a combination of the source reactance and shunt capacitance at a certain location, the impedance seen by the current source becomes very large. The effect of this is a large voltage distortion, even for moderate current distortion.

Parallel resonance occurs when the capacitive and inductive reactance cancel each other. The frequency at which this phenomenon occurs is called the parallel resonant

frequency. Neglecting the resistance, and with assumption $\omega = 2\pi f$, it can be expressed as follows

$$f_p = \frac{1}{2\pi} \sqrt{\frac{1}{LC}}$$

Where C can be the capacitance of capacitor bank or the shunt capacitance of long cables, and L can be the inductance of transformers or series reactors.

The ideal current source will lead to an infinite harmonic voltage at the connection bus and an infinite harmonic current through the capacitor and the inductor. The harmonic distortion will in practice be limited by two effects:

- The resistance present in the system will determine the impedance at the resonance frequency.
- The current source model is no longer valid for HV distortion.

The resonance phenomenon is especially common with MV capacitor banks. Also long AC cables can lead to a resonance but normally at higher frequencies where the amount of current distortion is less and the amount of damping is higher. Both WF components are present in analysed system and model as well.

There are certain instances when a shunt capacitor and the inductance of a transformer or long cables may appear as a series LC circuit to a source of harmonic currents. If the resonant frequency corresponds to a characteristic harmonic frequency of the analysed system, the LC circuit will attract a large portion of the harmonic current that is generated in the wind power plant.

III. SIMULATION RESULTS AND VALIDATION

A. Harmonic Emission

The harmonic power flow study has been conducted to determine fundamental and harmonic line currents and bus voltages for different models of the WT power converter.

Odd-harmonic distortion is typically dominant in power networks and WFs. Even-harmonic distortion of voltage or current is normally rather small as it can be seen in Fig. 5, 6. Even harmonics are generated by some large converters, but modern rules on harmonic distortion state that equipment should not generate any even harmonics [20]. In fact, a measurement of the supply voltage shows that the amount of even harmonics is indeed very small (see Fig. 5, 6). Even harmonics may be also generated by transformer energizing what should not be taken into consideration for steady state WF operation.

Generally it can be also observed that basis of measurement data study odd-harmonics multiple of 3 exist in the real system. It might be due to unbalances situation in the BBOWF during measurement time. During simulations unbalanced situation has not been taken into consideration. The main assumption has been to show obvious differences in results dependent on power electronic devices modelling. This has been also observable if balanced network representation has been studied.

Firstly certain period of measurement data has been processed using described above analysis methods applicable for stationary and quasi-stationary signals. The

blocks of the data have been chosen carefully to represent the BBOWF harmonic emission. Different time windows have been analysed and it was observed that harmonic measurements in the PCC are dependent on production, and day time.

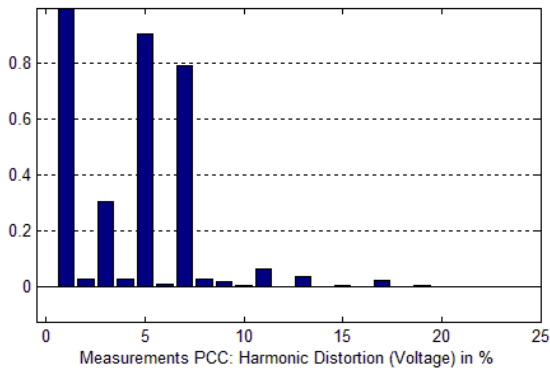

Fig. 5 Harmonic decomposition of measured voltage waveform. Voltage absolute value in % of the main harmonic is presented versus harmonic order.

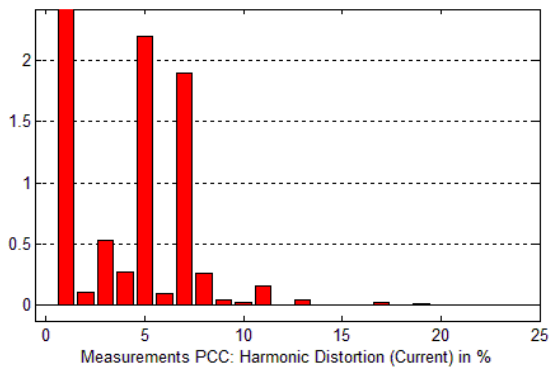

Fig. 6 Harmonic decomposition of measured current signal. Current absolute value in % of the main harmonic is presented versus harmonic order.

The spectrum analysis of the measurement data from the BBOWF shows that in both voltage waveform and current waveform the 5th harmonic dominates. This observation is not so obvious basis of simulation results. In case of the harmonic voltage source (in Fig. VSC) the 5th dominates only in the voltage harmonic plot, and when the harmonic current source (in Fig. CSC) is applied, the 7th harmonic dominates all the time.

From the harmonic emission analysis in the PCC it can be observed that both models are not able to give satisfactory results. Harmonics levels from the BBOWF measurements are somewhere between both obtained from calculations. The harmonic voltage source gives higher harmonic levels while the harmonic voltage source much lower than expectable. From the measurement data analysis of different periods during day and night it has been observed that harmonic levels, especially in case of 5th and 7th, had never been so high as observed in simulation with the harmonic current source and as low as it has been calculated from simulations with the harmonic voltage source.

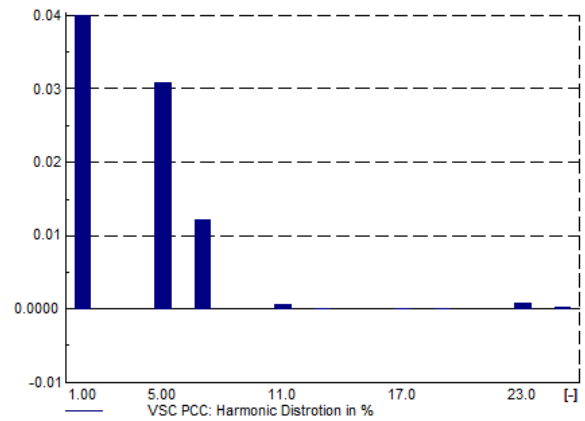
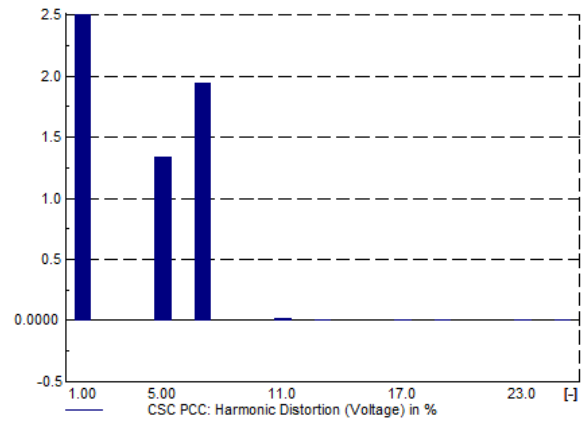

Fig. 7 Voltage harmonic emission of Burbo Bank offshore wind farm. Voltage absolute value in % is presented versus harmonic order.

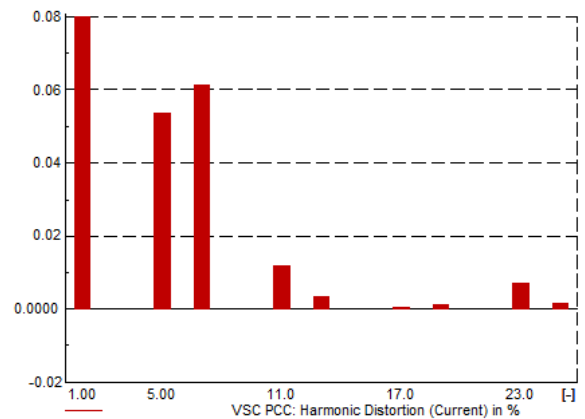
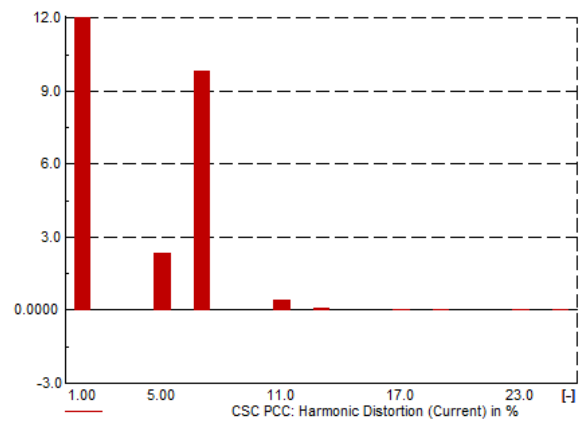

Fig. 8 Current harmonic emission of Burbo Bank offshore wind farm. Current absolute value in % is presented versus harmonic order.

B. Impedance Sweep

Harmonic studies are conducted to inspect the impact of non-linear devices and to analyse certain harmonic situations. They are aimed at detecting resonance and calculating distortion factors. An impedance scan, also known as a frequency scan, is a plot of the magnitude of driving point impedance at the bus of interests versus harmonic order or frequency and is useful in identifying resonance conditions. A dip occurring in the impedance value implies series resonance. Parallel resonance, on the other hand, is identified a sharp rise in the impedance value.

In the analysed in this paper study case, the system configuration has been constant. Only power converter as a harmonic source modelling method has been changed to show its influence on the whole system impedance in the PCC.

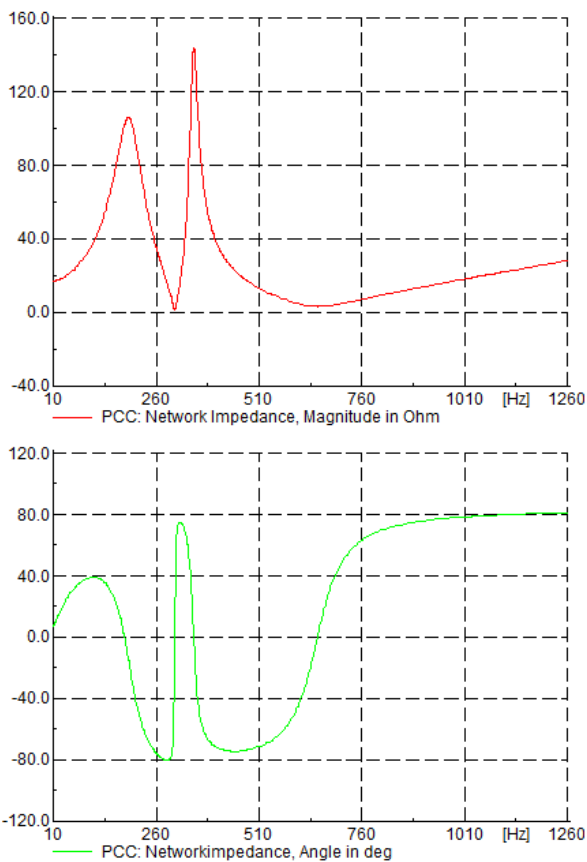

Fig. 9 Impedance plot in the point of common coupling from model with harmonic current source.

Different power converter models for harmonic load flow analysis have also shown that different modelling approach has an influence on harmonic impedance in the PCC. This affects harmonic level changes and in consequence WF harmonic emission assessment. It has been shown that appropriate power converter modelling can play a crucial role in analysis process and power quality assessment, especially before a certain WF would be established and measured in a real life.

In Fig. 9 and 10 is presented that there are different values and frequencies of resonance points in the frequency response at the PCC. This slight difference can have significant influence on harmonic assessment, especially if

there will be a harmonic source in the system corresponding resonance points.

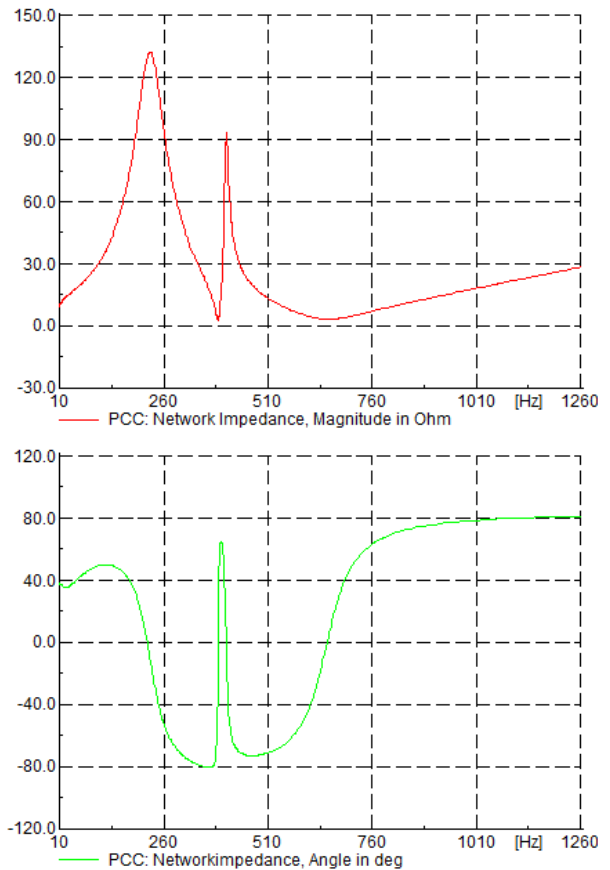

Fig. 10 Impedance plot in the point of common coupling from model with harmonic voltage source.

IV. Conclusion

It has been shown that classical harmonic analysis in frequency domain, which is normally used for assessment of disturbances to the public grid, could be insufficient. Lack of reliable models for power converters in relevant frequency range, manufacturer data normally are provided according to applicable standards [19], also contributes to obtain insufficient results. This shows that there is a need to define in standards appropriate WF components modelling.

Due to this fact every WF system configuration should be investigated separately in cooperation with manufacturers what increases modelling complexity and difficulties. This problem is not only with reference to harmonic analysis, it exists in all branches of modelling. It shows the necessity to extend data and models provided by manufacturers and to better describe modelling methods in standards.

Modelling strategies for harmonic sources for power system harmonic analysis are sometimes insufficient. Simulation techniques in the frequency, time and harmonic domains and modelling of the wind turbines as harmonic sources should be extended. The way to find a very good agreement between theory and experiment is necessary.

Power electronic converters for harmonic analysis can be simply represented by a harmonic current source suggested in standards or voltage source taking into consideration the

nature of back-to-back as voltage source inverters but unfortunately both cases give inappropriate results as it has been shown in the paper.

This paper shows the necessity to produce new knowledge of power converters, as a harmonic source, modelling. At present applied methods of full scale converters modelling are insufficient in reference to standards and measurements. In this paper differences between already developed models prepared for harmonic studies are shown. Not so good agreement between simulations and measurements as a premise for future work is shown. Both IEEE [16] and IEC [18] standards consider harmonics in a general sense, without regard to characteristic harmonics generated by certain types of equipment or special operation modes. The paper presents the need to extend harmonic sources description in standards.

V. REFERENCES

- [1] T. Ackerman, "Wind Power in Power Systems", John Wiley and Sons, 1 edition, 2005, p. 56.
- [2] N. R. Watson, J. Arrillaga, "Power System Harmonics", John Wiley and Sons, 2003.
- [3] A. Baghini, "Handbook of Power Quality", John Wiley and Sons, 2008.
- [4] M. Madrigal, E. Acha, "Power Systems Harmonics: Computer Modelling and Analysis", John Wiley and Sons, 2001.
- [5] George J. Wakileh, "Power Systems Harmonics: Fundamentals, Analysis, and Filter Design", Springer, 2001.
- [6] V. Akhmatov, J. Nygaard Nielsen, J. Thisted, E. Grøndahl, P. Egedal, M. Nørtoft Frydensbjerg, K. Høj Jensen, "Siemens Windpower 3.6 MW Wind Turbines for Large Offshore Windfarms", in Proc. *7th International Workshop on Large Scale Integration of Wind Power and on Transmission Networks for Offshore Wind Farms*, 26-27 May, 2008, p. 494-497.
- [7] C. H. Chien, R. W. G. Bucknall, "Theoretical Aspects of the Harmonic Performance of Subsea AC Transmission Systems for Offshore Power Generation Schemes", in Proc. *Generation Transmission and Distribution*, 2006, p. 599-609.
- [8] W. Wiechowski, P. B. Eriksen, "Selected studies on offshore wind farm cable connections – challenges and experience of the Danish TSO", in Proc. *Power and Energy Society General Meeting – Conversion and Delivery of Electrical Energy in the 21st Century*, 20-24 July 2008, p. 1-8.
- [9] *Long Term Development Statement, SP Manweb for the years 2008/09 to 2012/13*, ScottishPower, [Online] Available: <http://www.scottishpower.com/OtherDocuments.htm>
- [10] *DIGSILENT Power Factory manual*, v.14.0, DIGSILENT GmbH, 2008, Gomaringen, Germany.
- [11] P. W. Lehn, "Direct harmonic analysis of the voltage source converter", *IEEE Transactions on Power Delivery*, vol. 18, no. 3, July 2003, p. 1034-1042.
- [12] Sokratis T. Tentzerakis, Stavros A. Papathanassiou, "An Investigation of the Harmonic Emissions of Wind Turbines", *IEEE Transactions on Energy Conversion*, Volume 22, Issue 1, March 2007 p. 150-158.
- [13] S. Tentzerakis, N. Paraskevopoulou, S. Papathanassiou, P. Papadopoulos, "Measurement of wind farm harmonic emissions", in Proc. *IEEE Power Electronics Specialists Conference*, 15-19 June 2008, p. 1769-1775.
- [14] A. Faulstich, J. K. Steinke, F. Wittwer, "Medium Voltage Converter for Permanent Magnet Wind Power Generators up to 5 MW", EPE 2005 Dresden.
- [15] *High and extra high voltage 1*, EON grid codes, April 2006.
- [16] *IEEE Recommended Practices and Requirements for Harmonic Control in Electrical Power Systems*, IEEE Standard 519-1992.
- [17] Electromagnetic compatibility (EMC) – Part 2-12: *Environment – Compatibility levels for low frequency conducted disturbances and signalling in public medium-voltage power supply systems*, IEC 61000-2-12.
- [18] Electromagnetic Compatibility (EMC) Part 3: Limits – Section 6: *Assessment of Emission Limits for Distorting Loads in MV and HV Power Systems – Basic EMC Publication 1996*, IEC 61 000-3-6.
- [19] *Wind Turbine Generator Systems – Measurement and Assessment of Power Quality Characteristics of Grid Connected Wind Turbines*, 2008, IEC 61 400-21.
- [20] J. Arrillaga, N. R. Watson, S. Chen, "Power System Quality Assessment", New York, Wiley and Sons, 2000.
- [21] S. A. Papathanassiou, M. P. Papadopoulos, "Harmonic Analysis in a Power System with Wind Generation", *IEEE Transactions on Power Delivery*, vol. 21, no. 4, October 2006.
- [22] Y. Baghzouz, "Time-varying harmonics: Part II – Harmonic summation and propagation", *IEEE Transactions on Power Delivery*, vol. 17, no. 1, p. 279–285, January 2002.
- [23] A. Russo and P. Varilone, "Discussion of 'Time-varying harmonics: Part II – Harmonic summation and propagation'", *IEEE Transactions on Power Delivery*, vol. 18, no. 2, p. 656–657, April 2003.
- [24] *Electromagnetic Compatibility (EMC)—Part 4-7: Testing and Measurement Techniques – General Guide on Harmonics and Interharmonics Measurements and Instrumentation, for Power Supply Systems and Equipment Connected Thereto*, 2nd ed., IEC 61000-4-7, Aug. 2002.
- [25] A. D. Hansen, "Wind power in power systems", John Wiley & Sons, 2005.
- [26] DONG Energy, "Burbo Bank Offshore Wind Farm", [Online] Available: <http://www.dongenergy.com/burbo/index.htm>, October 2007.
- [27] L. Christensen, "powerLAB: Power quality measurement system for wind turbines" (in Danish), November 2005.
- [28] A. E. Kiprakis, A. R. Wallace, "Hybrid control of distributed generators connected to weak rural networks to mitigate voltage variation", In Proc. *17th International Conference on Electricity Distribution (CIRED)*, Barcelona, May 2003.
- [29] F. Z. Peng, "Harmonic sources and filtering approaches". *IEEE Industry Applications Magazine*, July/August 2001, p. 18-25.
- [30] *Siemens New 3.6 MW Direct-drive "Concept" Wind Turbine*, [Online] Available: <http://www.renewableenergyworld.com>

VI. BIOGRAPHIES

Lukasz Kocewiak was born in Grójec, Poland, in 1983. He received B.Sc. and M.Sc. degrees in electrical engineering from Warsaw University of Technology.

Currently he is an Industrial PhD student in cooperation with DONG Energy and Aalborg University. The main direction of his research is related with harmonics and nonlinear dynamics in power electronics and power systems.

Jesper Hjerrild was born in 1971. He received the M.Sc. and Ph.D. degrees in electrical engineering from the Technical University of Denmark, Lyngby, in 1999 and 2002, respectively.

Currently he has been employed at Dong Energy. His main technical interest is electrical power systems in general, involving a variety of technical disciplines including modelling of power system including wind power and power system control, stability and harmonics. Furthermore, he also works with designing of the wind farm

From 2002 until 2004 Jesper Hjerrild was employed at DEFU (The Association of Danish Energy Companies R&D).

Claus Leth Bak was born in Djursland, Denmark, in 1965. He received B. Sc. in Electrical Power Engineering from the engineering college in Århus in 1992, he received M.Sc. in Electrical Power Engineering in 1994.

He is an Associate Professor at Aalborg University with experience on high voltage engineering, relay protection for transmission systems and substation automation and dynamic analysis (PSCAD/EMTDC) of large power systems.