



Aalborg Universitet

AALBORG UNIVERSITY
DENMARK

Plug and Play Process Control of a District Heating System

Trangbaek, Klaus; Knudsen, Torben; Skovmose Kallesøe, Carsten

Published in:

Proceedings of the European Control Conference 2009

Publication date:
2009

Document Version
Publisher's PDF, also known as Version of record

[Link to publication from Aalborg University](#)

Citation for published version (APA):

Trangbaek, K., Knudsen, T., & Skovmose Kallesøe, C. (2009). Plug and Play Process Control of a District Heating System. In *Proceedings of the European Control Conference 2009* European Union Control Association.

General rights

Copyright and moral rights for the publications made accessible in the public portal are retained by the authors and/or other copyright owners and it is a condition of accessing publications that users recognise and abide by the legal requirements associated with these rights.

- ? Users may download and print one copy of any publication from the public portal for the purpose of private study or research.
- ? You may not further distribute the material or use it for any profit-making activity or commercial gain
- ? You may freely distribute the URL identifying the publication in the public portal ?

Take down policy

If you believe that this document breaches copyright please contact us at vbn@aub.aau.dk providing details, and we will remove access to the work immediately and investigate your claim.

Plug and Play Process Control of a District Heating System

Klaus Trangbaek, Torben Knudsen and Carsten Skovmose Kallesøe

Abstract—The main idea of plug and play process control is to initialise and reconfigure control systems automatically. In this paper these ideas are applied to a scaled laboratory model of a district heating pressure control system. First of all this serves as a concrete example of plug and play control, secondly some of the first techniques developed for these problems are demonstrated by experiments. The main emphasis is on incremental modelling and control in order to make it possible to “plug” in a new sensor or actuator and make it “play” automatically.

Index Terms—System identification; Incremental modelling; Plug and play process control; Reconfigurable systems; District Heating; Pressure control.

I. INTRODUCTION

A new housing sector is being planned, including a plan for a new district heating system. The planning shows that this calls for a redesign of the whole district heating system. However, it would be possible to change the system to a sector divided system, excluding the need for a total redesign, by introducing a number of pumps along the pipeline. Traditionally this requires a central and hard to implement control system. However, using a plug and play process control (P^3C) system, which can incorporate new actuators and sensors automatically, the whole design procedure is eliminated. This means that by using a P^3C system the above described control problem becomes easy and the cost is reduced considerably.

The idea of using pumps along the pipeline to increase the pressure gradually is proposed in [1]. Here the distributed pumps are used to enable the possibility for reducing the diameter of the pipes. The reduced diameter will decrease the surface area of the pipes and thereby the loss of heat along the pipeline. The control problem is not considered.

The example with the extended district heating system illustrates the idea behind P^3C . Here a redesign of the district heating system is described, but similar problems can be found in many everyday control problems spanning from ventilation of stables to control of heating systems in one-family houses.

Just as adaptive control, P^3C aims at identifying and adapting to changes in system behaviour. The crucial difference is that adaptive control deals with systems with fixed structure but varying parameters, where P^3C includes systems with varying structure. That could be adding an additional sensor or actuator, or adding a whole new subsystem.

This work is supported by The Danish Research Council for Technology and Production Sciences.

Trangbaek and Knudsen are with Automation and Control, Department of Electronic Systems, Aalborg University, Denmark. ktr@es.aau.dk
Kallesøe is with Grundfos A/S, Poul Due Jensens Vej 7, DK-8850 Bjerringbro, Denmark ckallesoe@grundfos.com

Ideally, this should happen fully automatised with a minimal need for excitation and staying in closed-loop. [2], [3], [4], [5] all present preliminary results on how to reconfigure controllers.

[6] also presents a strategy for plug and play control, using a fault-tolerant control approach, but the problem of model identification is not addressed.

In [7], incremental modelling by least squares methods is discussed and demonstrated on a simulation example of a district heating system. In this paper, that methodology is tested by experiments on a laboratory model, demonstrating that it is capable of dealing with a more realistic setting.

II. PLUG AND PLAY FOR DISTRICT HEATING PRESSURE CONTROL

In this work a simplified district heating system is considered. This is a minimal system with only one heat source and only two consumers (heat users). A sketch of the system is shown in Fig. 1.

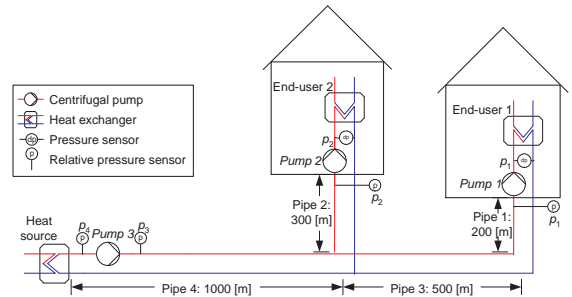

Fig. 1. A sketch of the very small district heating system, which forms the basis for the laboratory model.

The boundaries of the pipeline system under consideration consist of the secondary side of the heat source, which can be modelled as a constant valve, and the primary side of the heat exchangers at the end-users, which both can be modelled as variable valves. The latter two heat exchangers are controlled by the heating system of the buildings and can therefore be regarded as disturbances. The controllable inputs are the speed for the three pumps, one main pump $pump_3$ and two building pumps $pump_2$ and $pump_1$. Further, there are eight pipes connecting everything. The measurable outputs are delivered by pressure sensors, dp_2 , dp_1 , and $dp_{43} = p_3 - p_4$.

The pressure sensor and pump in the last building are the devices which are not present in the initial system but which are finally added in the plug and play fashion.

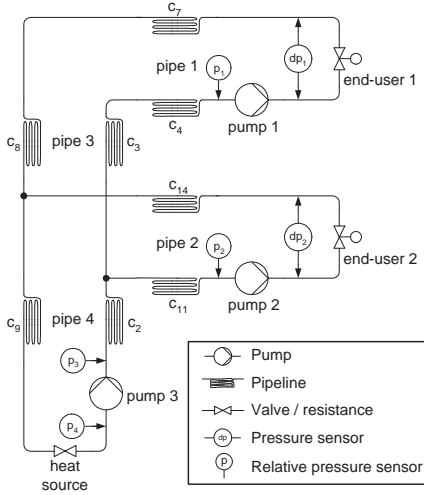

Fig. 2. The hydraulic network of the district heating system in Fig. 1.

TABLE I

THE PARAMETERS OF THE EXAMPLE SYSTEM DEPICTED IN FIG. 1.

Pipe no.	Length	Diameter
Pipe 1	$l_{c_4}=l_{c_7}=200$ [m]	$d_{c_4}=d_{c_7}=0.48$ [m]
Pipe 2	$l_{c_{11}}=l_{c_{14}}=300$ [m]	$d_{c_{11}}=d_{c_{14}}=0.48$ [m]
Pipe 3	$l_{c_3}=l_{c_8}=500$ [m]	$d_{c_3}=d_{c_8}=0.60$ [m]
Pipe 4	$l_{c_2}=l_{c_9}=1000$ [m]	$d_{c_2}=d_{c_9}=0.60$ [m]

III. A SCALED LABORATORY MODEL FOR THE DISTRICT HEATING SYSTEM

In [1] it is argued that the heat losses in district heating system can be lowered by decreasing the diameter of the pipes and thereby the pipe surfaces. The cost is that the pressure losses in the system will increase. A solution for accommodating these additional pressure losses is to introduce distributed pumping.

To investigate different control approaches for this new kind of district heating system a laboratory model is designed. The basis for this model is the very small district heating system with only two end-users (heat customers) shown in Fig. 1.

The end user flow rate is best controlled when the differential pressures across the heat exchangers are constant. In fact, traditionally the pump in a district heating system is controlled such that, at least, at one point in the system the pressure is constant at a 0.5 [bar] [8]. This means that the task of the control is to keep the pressure constant at the end-users under all possible load conditions.

When pressure control is considered it is only necessary to consider the hydraulic parts of the example system shown in Fig. 1. A diagram of the hydraulic components are shown in Fig. 2, and the pipe parameters are shown in Table I. The hydraulic system is here designed for a max flow of 10 [m^3/h] with a pressure at 0.5 [bar] at each of the end-users. At these design points the two end-user pumps deliver approximately 1 [bar] and pump 3 delivers approximately 2.5 [bar].

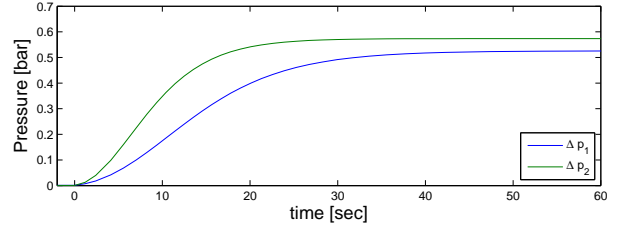

Fig. 3. Result of a simulation of a speed step from 0 to 100 % speed of all pumps in network depicted in Fig. 2 with the pipe parameters shown in Table I.

TABLE II

THE PARAMETERS OF THE DOWNSCALED SYSTEM.

Pipe no.	Length	Diameter
Pipe 1	$l_{c_4}=l_{c_7}=6$ [m]	$d_{c_4}=d_{c_7}=0.01$ [m]
Pipe 2	$l_{c_{11}}=l_{c_{14}}=9$ [m]	$d_{c_{11}}=d_{c_{14}}=0.01$ [m]
Pipe 3	$l_{c_3}=l_{c_8}=15$ [m]	$d_{c_3}=d_{c_8}=0.02$ [m]
Pipe 4	$l_{c_2}=l_{c_9}=25$ [m]	$d_{c_2}=d_{c_9}=0.02$ [m]

General simulation models of hydraulic systems on the form shown in Fig. 2 are derived in [9]. Using this modelling approach the dynamics of the example system is simulated during a speed step on all pumps from 0 to 100 %. The results are shown in Fig. 3.

The system shown in Fig. 2 is not feasible for a operational test setup, due to the size and length of the piping. Therefore the system is downscaled such that the max flow is set to 0.5 [m^3/h] at a pressure of 0.2 [bar] at each end-user. At these design points the end-user pumps should deliver 0.4 [bar] and pump 3 should deliver 0.5 [bar]. The length and diameter of the pipes are in this case chosen, such that the dynamics of the lab model is approximately 10 times faster than the example system. The pipe parameters are given in Table II. The values for the pipe parameters are chosen based partly on dynamic consideration and partly on the practical implementation. A picture of the test setup is shown in Fig. 4. In the downscaled system the pressure reference is chosen to be 0.2 [bar] compared to the 0.5 [bar] in the example system.

The end users are modelled by controllable valves. Typical consumer behaviour can then be emulated by applying position commands with a relatively low frequency content to these valves.

The dynamics of the downscaled system are both simulated and tested. The results are shown in Fig. 5. Comparing the example system and the downscaled system it is seen that the dynamics are approximately 10 times slower for the downscaled system, as it was expected. Moreover, it is seen that the dynamics between the speed changes and the two pressure measurements are more alike for the downscaled system, and that the steady state values are different in the two systems. This is because the system components are not scaled one to one, as it was not intention to get a correct downscaled system, rather to get a feasible model with the same features at the real system. This is in fact the case for the downscaled system.



Fig. 4. Picture of the test setup.

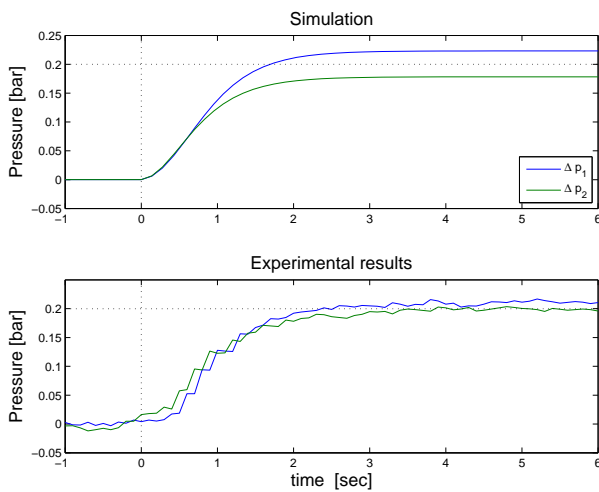

Fig. 5. Top: Result of a simulation of a speed step from 0 to 100 % speed of all pumps in network depicted in Fig. 2 with the pipe parameters shown in Table II. Bottom: Experiment on the laboratory test bench.

Comparing the simulation results and the results from the test setup it is seen that the dynamics are comparable. On the other hand the steady state difference between the two pressures is larger in the case of the simulation, probably due to unpredicted pressure losses in the system due to pipe bendings.

In conclusion, we have obtained a laboratory setup that nicely approximates the expected behaviour of a real life district heating system.

IV. SYSTEM IDENTIFICATION METHODS FOR PLUG AND PLAY

In system identification (SI) the goal is always to obtain the best model for the purpose. The special situation in P³C modelling is when there is a known “present” model and a new device appears. The question is then if new and better SI methods can be developed for this situation.

This section presents the developed methodology. Parts of the following have already been presented in [7], but is

included here for completeness.

A. Plug and Play modelling

In all the modelling development in P³C the first objective is models which are useful for control. From this follows that simple models, e.g linear time invariant, is a high priority.

As explained in section II the “initial” system is without pump and sensors in the last building. A “commissioning” model is first made for this system. The idea is that the initial 2 output \times 2 input system is excited in open loop under the commissioning phase and a model is produced. This is done in a (semi) automatic way using quite standard SI methods and cross validation. The result is a Hammerstein model (see [7]) that is an LTI model where the inputs are squared pump speeds. This will however not be further discussed here but explains the existence of the “present” 2 \times 2 model.

When a new device announces its entrance on the network a process towards model updating starts. The modelling and update must be done in closed loop. One possibility would of course be to start from scratch as if nothing was known already. As a well-performing present model and controller is assumed, it seems wiser to build on top of this. The advantages are that the known part of the model remains the same, there are fewer parameters to estimate and for new actuators not all inputs but only the new one needs excitation.

Standard prediction error (PE) methods can be used for estimating the necessary new parameters while the present parameters are fixed. This is e.g. possible with PEM from the MatLab toolbox IDENT [10]. PE methods use iterative non-convex numerical minimisation. However, especially for online use, more simple and robust methods are preferable. Methods using only convex minimisation are therefore developed below.

For this purpose state space (SS) models in innovation form is appropriate. The least squares (LS) method developed can be separated in two steps. First the state (or other signals) are generated from the known present model assuming it is correct. Then the additional parameters can be estimated in an LS fashion from the output equation which includes the additional device. For both the additional input and output case it is important how this signal generating is done. To show this it is necessary to review some of the stochastic description for SS models.

Given the SS model in innovation form

$$x(t+1) = Ax(t) + Bu(t) + Ke(t) \quad (1a)$$

$$y(t) = Cx(t) + Du(t) + e(t) \quad (1b)$$

$$E(e(t)e(s)^T) = \delta_{ts}R, E(e(t)) = 0 \Rightarrow R = \text{Cov}(e) \quad (1c)$$

Then the mean value and corresponding deviation to state and measurement are

$$\mu_x(t+1) = A\mu_x(t) + Bu(t) \quad (2a)$$

$$\mu_y(t) = C\mu_x(t) + Du(t) \quad (2b)$$

$$\left. \begin{aligned} \delta_x(t) &\triangleq x(t) - \mu_x(t), \\ \delta_y(t) &\triangleq y(t) - \mu_y(t) \end{aligned} \right\} \Rightarrow \quad (2c)$$

$$\delta_x(t+1) = A\delta_x(t) + Ke(t), \quad (2d)$$

$$\delta_y(t) = C\delta_x(t) + e(t), \quad R = \text{Cov}(e) \quad (2e)$$

For one step predictions there is no stationary error between state (1a) and prediction (3a) in a innovation model as $x(t) \triangleq \hat{x}(t) \triangleq E(x(t)|Y^{t-1})$ by construction. Here Y^{t-1} is the measurement until and including time $t-1$. This gives a prediction error for output y which is white (3c).

$$x(t+1) = (A - KC)x(t) + (B - KD)u(t) + Ky(t) \quad (3a)$$

$$\hat{y}(t) = Cx(t) + Du(t) \Rightarrow \quad (3b)$$

$$y(t) - \hat{y}(t) = e(t) \Leftrightarrow \quad (3c)$$

$$y(t) = \hat{y}(t) + e(t), \quad R = \text{Cov}(e) \quad (3d)$$

B. Including an additional actuator

Based on the above the LS solution for a additional input is developed. In this case the SS model can be divided as (4)–(5) where subscript p and a means present and additional respectively e.g. u_p are the inputs in the present/initial system and u_a is the additional input.

$$x_p(t+1) = A_p x_p(t) + (B_p \quad B_{pa}) \begin{pmatrix} u_p(t) \\ u_a(t) \end{pmatrix} + K_p e_p(t) \quad (4)$$

$$y_p(t) = C_p x_p(t) + (D_p \quad D_{pa}) \begin{pmatrix} u_p(t) \\ u_a(t) \end{pmatrix} + e_p(t), \quad (5)$$

$$R_p = \text{Cov}(e_p)$$

$$u_p \in \mathcal{R}^m, \quad u_a \in \mathcal{R}, \quad x_p \in \mathcal{R}^n, \quad y_p, e_p \in \mathcal{R}^l \quad (6)$$

Then it is only necessary to estimate B_{pa}, D_{pa} . Notice that both the mean output and the predicted output are linear in these parameters. This means the output can be separated in a part from the present system and a linear combination of sequences, where each sequence is generated by assuming that one new parameter is one while the rest are zero.

Define y_0 as the output from the present system i.e. where all additional parameters i.e. B_{pa}, D_{pa} are zero and y_i as the output where B_p, K_p, D_p and all additional parameters are zero except number i which is one. Then the output is a linear combination of these signals.

If the one step predictor (3a)–(3b) is used to generate the signals y_i , then the relation between measurements and signals is (7), where e_p is the innovation. If the “mean” filter (2) generates the signals y_i the relation is also (7), except the innovation e_p is replaced with the deviation δ_y given in (2e).

$$y_p(t) = y_0(t) + \sum_{i=1}^{n+l} \theta_i y_i(t) + e_p(t), \quad (7)$$

$$(\theta_1 \quad \dots \quad \theta_n)^T \triangleq B_{pa}, \quad (\theta_{n+1} \quad \dots \quad \theta_{n+l})^T \triangleq D_{pa} \quad (8)$$

If signals for the whole measurement sequence are stacked into vectors and some more notation is introduced, (7) can be turned into a linear regression equation (10) with the LS

solution (11).

$$\left. \begin{aligned} Y_p &\triangleq \begin{pmatrix} y_p(1) \\ \vdots \\ y_p(N) \end{pmatrix} \text{ and similarly for } Y_i, E_p, \\ \Theta &\triangleq (\theta_1 \quad \dots \quad \theta_{n+l})^T, \\ X &\triangleq (Y_1 \quad \dots \quad Y_{n+l}), \quad Z \triangleq Y_p - Y_0 \end{aligned} \right\} \Rightarrow \quad (9)$$

$$Y_p = Y_0 + \theta_1 Y_1 + \dots + \theta_{n+l} Y_{n+l} + E_p, \quad (10)$$

$$Z = X\Theta + E_p \quad \hat{\Theta} = (X^T X)^{-1} X^T Z \quad (11)$$

As shown in [7], this estimate is consistent, both in open and closed loop.

In contrast, if mean values are used then the rows in E_p will be auto correlated as they consist of $\delta_y(t)$ (2e) and the variance will be large compared to the prediction errors. Still, no bias will occur in open loop as the mean values are only generated from input u . In closed loop, bias will occur because then u is correlated with y which is correlated with $\delta_y(t)$.

C. Including an additional sensor

If the new device is a sensor the new system is then given by (12)–(13).

$$x_p(t+1) = A_p x_p(t) + B_p u_p(t) + (K_p \quad K_{pa}) \begin{pmatrix} e_p(t) \\ e_a(t) \end{pmatrix} \quad (12)$$

$$\begin{pmatrix} y_p(t) \\ y_a(t) \end{pmatrix} = \begin{pmatrix} C_p \\ C_{ap} \end{pmatrix} x_p(t) + \begin{pmatrix} D_p \\ D_{ap} \end{pmatrix} u_p(t) + \begin{pmatrix} e_p(t) \\ e_a(t) \end{pmatrix}, \quad R = \begin{pmatrix} R_p & R_{pa} \\ R_{ap} & R_a \end{pmatrix} = \text{Cov} \begin{pmatrix} e_p \\ e_a \end{pmatrix} \quad (13)$$

$$u_p \in \mathcal{R}^m, \quad x_p \in \mathcal{R}^n, \quad y_p, e_p \in \mathcal{R}^l, \quad y_a, e_a \in \mathcal{R} \quad (14)$$

An LS solution for an additional output should ideally estimate $C_{ap}, D_{ap}, K_p, K_{pa}$ and the covariance R . It could be tempting also to fix K_p and R_p as they “belong” to the present model. However, this will only be correct in the special case where the additional output is independent of the present output because then the state estimate is additive in the two outputs.

If the present model is correct it can be used to generate the mean state for the present system. This will be exactly the same as the mean state for the new system. Then the output equation for the additional sensor can be used to make a LS estimate for C_{ap}, D_{ap} as follows.

$$\mu_{y_a}(t) = C_{ap} \mu_x(t) + D_{ap} u(t) \Rightarrow \quad (15a)$$

$$y_a(t) = C_{ap} \mu_x(t) + D_{ap} u(t) + \delta_{y_a}(t) \quad (15b)$$

$$\left. \begin{aligned} Y_a &\triangleq \begin{pmatrix} y_a(1) \\ \vdots \\ y_a(N) \end{pmatrix}, \quad X \triangleq \begin{pmatrix} \mu_x(1)^T & u(1)^T \\ \vdots & \vdots \\ \mu_x(N)^T & u(N)^T \end{pmatrix}, \\ \Theta &\triangleq (C_{ap} \quad D_{ap})^T \end{aligned} \right\} \Rightarrow \quad \hat{\Theta} = (X^T X)^{-1} X^T Y_a \quad (15c)$$

Similar to additional input this will not give bias in OL but it will in CL. If the mean state in (15) is interchanged with the present state predictor (3) it can be shown that this gives a consistent estimate for the deterministic part C_{ap}, D_{ap} [12].

The stochastic part $K = (K_p \ K_{pa}), R$ is far more difficult to estimate. Parameter estimation so far has been done solving only convex minimisation problems. If we limit ourselves to these numerical robust methods there is only a approximative, normally biased, estimate for the stochastic part [12]. If also non convex minimisation methods are included there exist a consistent PEM estimate for the stochastic part [13].

V. EXPERIMENTAL RESULTS

Results from using the methods and scenario from Section IV on the laboratory test setup described in Section III are presented below. In short the scenario is as follows; At first the dp_1 sensor and $pump_1$ are not present. An existing controller $C_{2 \times 2}$ is keeping dp_2 at the reference, suppressing disturbances from both end-users and also keeping $dp_{43} = p_3 - p_4$ at 0.3 bar using $pump_2$ and $pump_3$. dp_1 and $pump_1$ are then added and a model of their connection to the system is identified. Using the new model, a new controller $C_{3 \times 3}$ is designed and implemented. In the following, this will be described in more detail. Selected time intervals are shown in Fig. 6. The numbers in the bottom plot refer to intervals separated by dotted lines.

A. Experiment setup

All modelling and control takes place in discrete time with a sampling time of 0.4s. The valve positions act as unknown disturbances emulating varying heat consumption. This is done by applying white noise filtered by a first order linear filter with a pole in $z = 0.98$, corresponding to a 20 second time constant, again corresponding to a 200 second time constant in real life.

There is a nonlinearity in the system, which can be modelled as a Hammerstein system. The behaviour is linearised by applying the inverse nonlinearity to the pump signals before applying them to the system. The pump commands shown in the plot are the actual pump commands, scaled to have 1 corresponding to full power.

B. Existing controller

At the commissioning of the system, excitation was applied in open loop to $pump_3$ and $pump_2$. From the dp_2 and dp_{43} measurements, a reliable 2×2 innovations model was then identified. From this model, an LQG controller $C_{2 \times 2}$ was designed and implemented keeping dp_2 at 0.2 bar and dp_{43} at 0.3 bar.

C. Interval 1: a new sensor is added

At end user 2, the performance is satisfactory, but complaints from end user 1 indicate that the pressure may not be sufficient. Therefore, the pressure sensor dp_1 is added to the system, yielding the measurements shown in Interval 1, revealing that the pressure is indeed too low.

D. Interval 2: excitation

In order to be able to separate effects of disturbances and control signals, excitation is added to $pump_3$ and $pump_1$ in the form of steps added to the control signals in closed loop with $C_{2 \times 2}$.

The model is extended to include the new output using the LS method in Section IV-C. The stochastic part is not updated.

E. Interval 3: a new actuator is added and excited

From the obtained 3×2 model it is concluded that dp_1 cannot be controlled in a satisfactory manner using the existing pumps. Therefore, the $pump_1$ is added and excited with a number of steps, while $C_{2 \times 2}$ remains in control.

Using the method described in Section IV-B, generating the signals by the one step predictor, the 3×2 model is appended with the new input.

F. Interval 4: new controller

With the new 3×3 model, a new controller, $C_{3 \times 3}$, is designed. Reflecting the uncertainty of the new parts of the model, additional penalty is put on the new input in the control design compared to the other pumps, increasing robustness but slightly lowering performance.

The results of applying $C_{3 \times 3}$ are seen in Interval 4. dp_1 is now maintained at desired level without affecting performance at dp_2 or significantly increasing the control inputs of $pump_3$ or $pump_2$.

Thus, it is demonstrated how an almost automatic and closed-loop approach can be used when adding devices. A few issues, such as how to automatically choose excitation levels, still remain. In this example the nonlinearity was expected to be the same in all the inputs and could thus be compensated for, but how to deal with nonlinearities in general is an open question.

In some cases, adding devices will lead to additional dynamics. Indeed, in the experiment, the dynamics of the pipe 1 loop are only fully revealed when adding the dp_1 sensor. Identifying these dynamics could probably yield better performance. Methods for incremental modelling with additional dynamics are currently investigated, see e.g. [14].

VI. CONCLUSION

Using model based control design calls for new/updated models when a new device enters the system. Methods for this is the focus of this paper. Since a good model for the present system is assumed, it is chosen to keep this and only estimate the new part. It is investigated what can be achieved with LS methods i.e. avoiding iterative numerical minimisation.

The developed LS methods are used with success in an experiment on a laboratory model of a district heating system, where a new sensor and a new actuator are added to the system. Using almost fully automated methods, the model and consequently the control system are updated, resulting in improved performance.

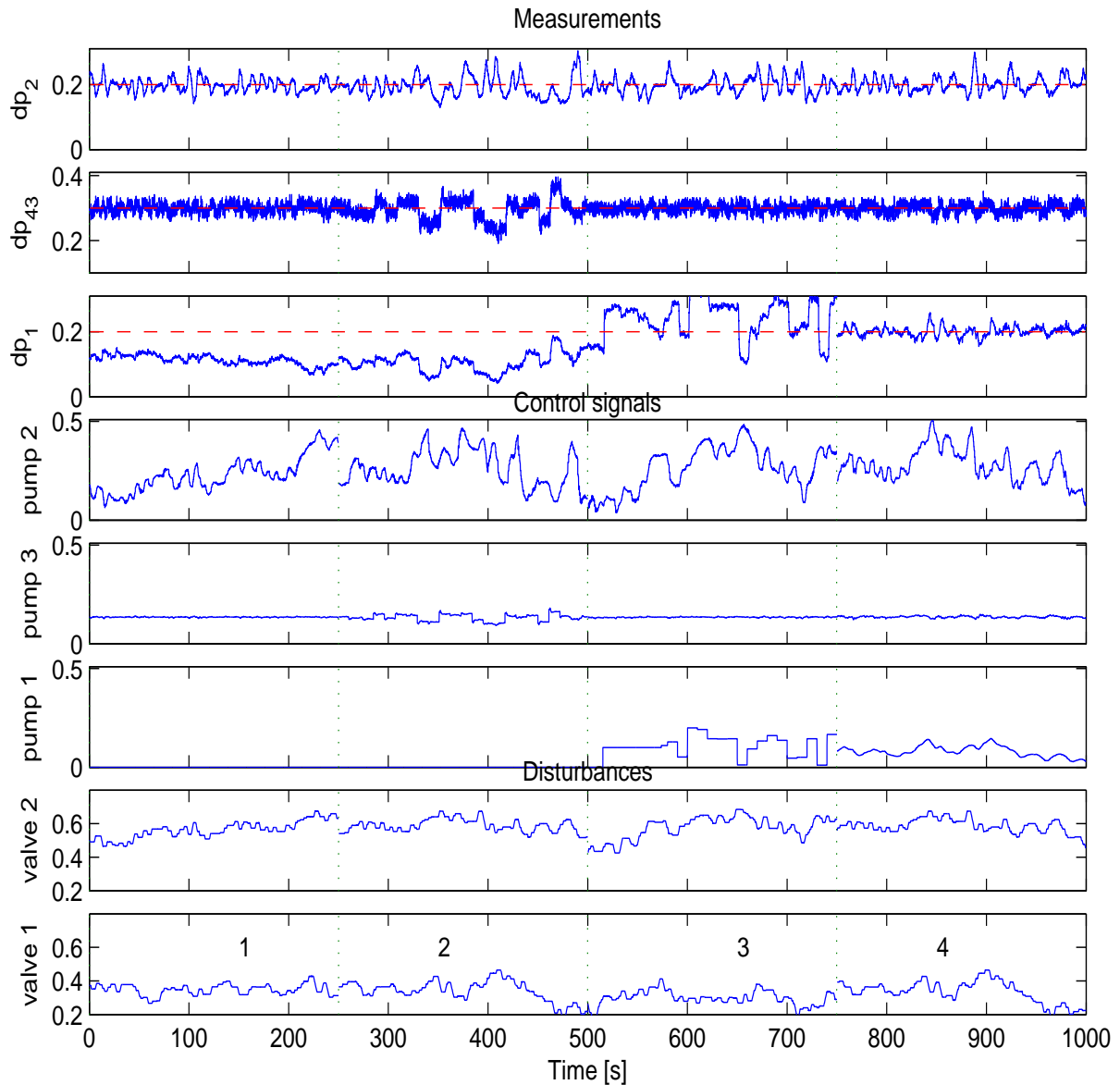

Fig. 6. Experimental example. Differential pressures (measured outputs), pump speeds (controlled inputs) and valve positions (unknown disturbances). Notice the dotted lines separating the different steps in the reconfiguration procedure.

REFERENCES

- [1] F. Bruus, B. Bøhm, N. K. Vejen, J. Rasmussen, N. Bidstrup, K. P. Christensen, and H. Kristjansson, "Efp-2001 fjernvarmeforsyning af lavenergiomrder," Danish Energy Authority, Tech. Rep. Journal No. 1373/01-0035, 2004, in Danish.
- [2] J. Bendtsen, K. Trangbaek, and J. Stoustrup, "Plug-and-play process control: Improving control performance through sensor addition and pre-filtering," in *Proceedings of the 17th IFAC World Congress*, Seoul, Korea, July 2008.
- [3] A. G. Michelsen, R. Izadi-Zamanabadi, and J. Stoustrup, "Towards automatic model based controller design for reconfigurable plants," in *17th IFAC World Congress (IFAC'08)*, IFAC. IFAC, 2008.
- [4] K. Trangbaek, J. Stoustrup, and J. Bendtsen, "Stable controller reconfiguration through terminal connections," in *Proceedings of the 17th IFAC World Congress*, Seoul, Korea, July 2008.
- [5] M. Kragelund, R. Wisniewski, T. Mølbak, R. J. Nielsen, and K. Edlund, "On propagating requirements and selecting fuels for a Benson boiler," in *17th IFAC World Congress (IFAC'08)*, 2008.
- [6] C. Kambhampati, R. J. Patton, and F. J. Uppal, "Reconfiguration of plug-and-play network of embedded systems," *Mechatronic Systems*, vol. 4, no. 1, pp. 1065–1070, 2006.
- [7] T. Knudsen, K. Trangbaek, and C. S. Kalløse, "Plug and play process control applied to a district heating system," in *17th IFAC World Congress (IFAC'08)*, 2008, pp. 325–330.
- [8] B. Bøhm and H. V. Larsen, "Efp-2001 simple models of district heating systems -for load and demand side management and operational optimization," Danish Energy Authority, Tech. Rep. Journal No. 1373/01-0041, 2004, in Danish.
- [9] C. D. Persis and C. S. Kalløse, "Pressure regulation in nonlinear hydraulic networks by positive controls," in *Submitted for conference, in review*, 2009.
- [10] L. Ljung, *System Identification Toolbox*, The MathWorks, Inc., 2007.
- [11] —, *System Identification, Theory for the User*, 2nd ed., ser. Prentice-Hall information and system sciences series. Prentice-Hall, 1999.
- [12] T. Knudsen, "Incremental data driven modelling for plug and play process control," in *to appear at ECC09*, 2009.
- [13] —, "Awareness and its use in plug and play process control," in *to appear at ECC09*, 2009.
- [14] J. D. Bendtsen, K. Trangbaek, and J. Stoustrup, "Closed-loop system identification with new sensors," *IEEE Conf. Decision and Control*, pp. 2631–2636, 2008.