



AALBORG UNIVERSITY
DENMARK

Aalborg Universitet

Strengths and Weaknesses of Different Approaches of IDP

Brunsgaard, Camilla

Publication date:
2009

Document Version
Publisher's PDF, also known as Version of record

[Link to publication from Aalborg University](#)

Citation for published version (APA):

Brunsgaard, C. (2009). *Strengths and Weaknesses of Different Approaches of IDP*. Department of Civil Engineering, Aalborg University. DCE Technical reports No. 74

General rights

Copyright and moral rights for the publications made accessible in the public portal are retained by the authors and/or other copyright owners and it is a condition of accessing publications that users recognise and abide by the legal requirements associated with these rights.

- ? Users may download and print one copy of any publication from the public portal for the purpose of private study or research.
- ? You may not further distribute the material or use it for any profit-making activity or commercial gain
- ? You may freely distribute the URL identifying the publication in the public portal ?

Take down policy

If you believe that this document breaches copyright please contact us at vbn@aub.aau.dk providing details, and we will remove access to the work immediately and investigate your claim.

Strengths and weaknesses of different approaches of IDP

Camilla Brunsgaard

Aalborg University
Department of Civil Engineering
Architectural Engineering

DCE Technical Report No. 74

Strengths and weaknesses of different approaches of IDP

by

Camilla Brunsgaard

August 2009

© Aalborg University

Scientific Publications at the Department of Civil Engineering

Technical Reports are published for timely dissemination of research results and scientific work carried out at the Department of Civil Engineering (DCE) at Aalborg University. This medium allows publication of more detailed explanations and results than typically allowed in scientific journals.

Technical Memoranda are produced to enable the preliminary dissemination of scientific work by the personnel of the DCE where such release is deemed to be appropriate. Documents of this kind may be incomplete or temporary versions of papers—or part of continuing work. This should be kept in mind when references are given to publications of this kind.

Contract Reports are produced to report scientific work carried out under contract. Publications of this kind contain confidential matter and are reserved for the sponsors and the DCE. Therefore, Contract Reports are generally not available for public circulation.

Lecture Notes contain material produced by the lecturers at the DCE for educational purposes. This may be scientific notes, lecture books, example problems or manuals for laboratory work, or computer programs developed at the DCE.

Theses are monographs or collections of papers published to report the scientific work carried out at the DCE to obtain a degree as either PhD or Doctor of Technology. The thesis is publicly available after the defence of the degree.

Latest News is published to enable rapid communication of information about scientific work carried out at the DCE. This includes the status of research projects, developments in the laboratories, information about collaborative work and recent research results.

Published 2009 by
Aalborg University
Department of Civil Engineering
Sohngaardsholmsvej 57,
DK-9000 Aalborg, Denmark

Printed in Aalborg at Aalborg University

ISSN 1901-726X
DCE Technical Report No. 74

Table of contents

1. Introduction	6
1.1 Method	6
1.2 The preferred IDP approach from the author's point of view	7
2. Description of three integrated design approaches	8
2.1. Integrated Design Process. A guideline for sustainable and solar-optimised building design, IEA Task 23	8
2.2. Integrated Design Process – in a problem based learning environment, AAU	10
2.3. Method for integrated design, DTU	12
3. Application experiences of the IDP method by DTU for design of single family houses	16
3.1 Exercise	16
3.2 Summing up the process in the exercise	16
4. Discussion of different IDP approaches	17
5. Conclusion	19
6. References	20
7. Appendix	21

1. Introduction

The build environment in Europe will in the near future meet large challenges in reducing the energy consumption and environmental impact. With the EU Energy Performance of Buildings Directive (EPBD) new buildings and renovation projects need to improve the energy performance which also includes a regulatory for the indoor environment [1]. Many design decisions affect both the energy performance and the indoor environment of the building and therefore it can be difficult to overview what the consequences are for a certain design decision. In order to design better buildings which both meet the new performance demands and has a satisfying level of architectural quality it is necessary to work in an integrated way, use the method of the Integrated Design Process (IDP).

The problem in the Traditional Design Process (TDP) is mainly that the client and the architect agree on the design and the engineers are later asked to implement or “ad on” their systems. This approach rarely results in optimum solutions for the client.

This process works as a linear process and a lot of resources are today used to solve unexpected problems in the detailing phase or even later when the buildings already have been build [2] e.g. overheating in summer because of too much glazed area to the south, lack of daylight conditions or “added on” features which result in clumsy architecture. Now it is even more important to work integrated than ever before because of the new directive. Small mistakes have relatively bigger influence now on the performance of the building because the energy requirements are stricter.

Since the method IDP has been presented for the first time several people have written about and worked with the concept. It has led to more definitions of the same concept. At a course at the Technical University of Denmark (DTU) called “Integrated Design of Low- Energy Buildings” (October 2007) one of the newer definitions of the method IDP was presented and discussed. In connection to that it also showed that different professional competences had different understandings of words in a Design Process. Both architects, engineers, professors, consultants and manufacturer were represented.

Because of the different interpretations of words and other definitions of the integrated design process, this article will create an overview of some of design methods and describe the different strengths and weaknesses.

The new approach from DTU will also be discussed and evaluated in connection to designing single family houses, which is the building type the author’s Ph.D. study is focusing on.

1.1 Method

This study is based on literature studies of different design processes. Additionally experiences from the course “Integrated Design of Low- Energy Buildings” at DTU will be involved.

The following section will contain a short overall description of three different approaches to IDP. The primary references have to be studied if one wants a deeper understanding of the definitions.

The three different approaches are:

- Integrated Design Process. A guideline for sustainable and solar-optimised building design, IEA Task 23 (Task 23) [2]
- Integrated Design Process –in a problem based learning environment, Aalborg University, Architecture & Design (AOD) [3] [4]
- Method for integrated design, Technical University of Denmark (DTU) [5] [6]

The processes will be described through the following points:

- motivation and goal for development of the design process
- short description of the characteristics of the method
- key persons or stake holders in the process
- design phases
- process development
- design goals/ parameters
- tools
- strengths and weaknesses
- examples

The methods strengths and weaknesses will be evaluated from two points of view.

- 1) What the method describes it wants to accomplish, defined in “goals for development of the design process”.
- 2) What in the author’s opinion an IDP should solve.

1.2 The preferred IDP approach from the author’s point of view

Figure 1 below illustrates in a good way how the author sees integrated design. Integrated design is where all parameters of a building are considered and incorporated into one holistic building design. It means that both technical, functional, aesthetical and architectural qualities in a design is incorporated into each other so the building both can be used, express and work as desired. All these parameters can seem complex to combine in one building, especially because some of them lead to contradicting solutions. To get an overview of all the parameters in a building design the solution is to work with the IDP method. The question is just which method to use?

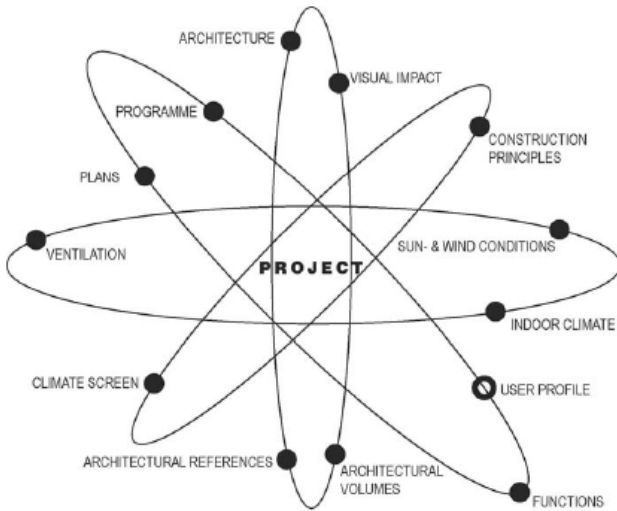


Figure 1: It illustrates parameters of the IDP from AOD [3]

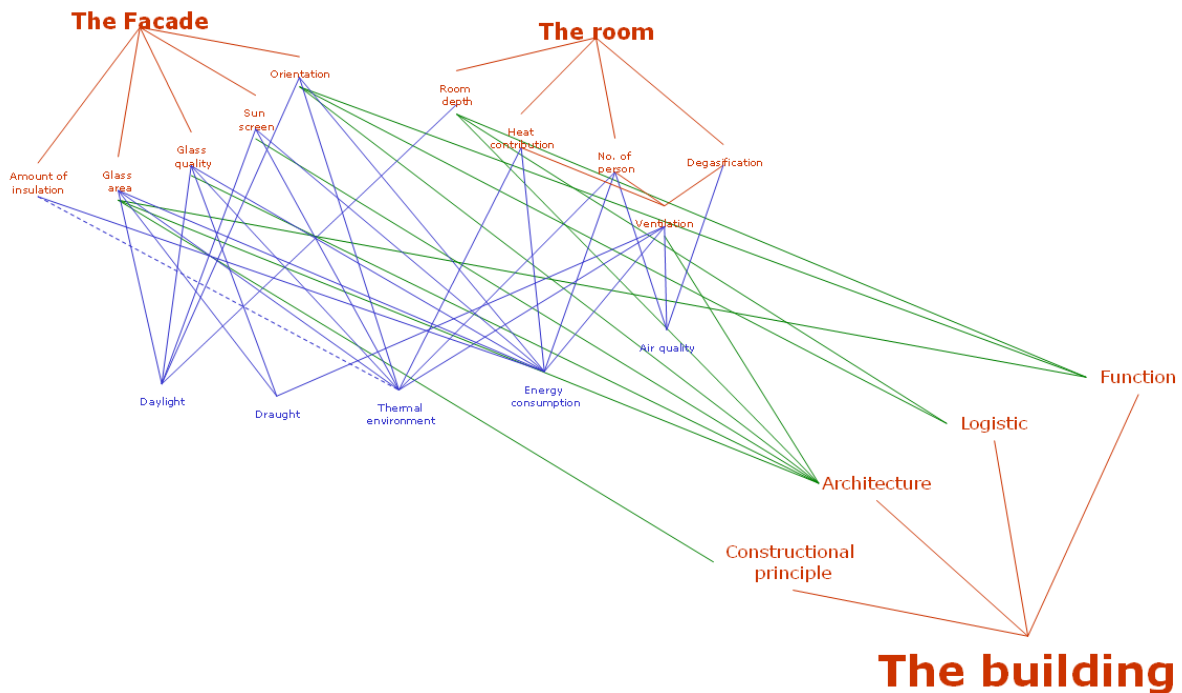


Figure 2: It illustrates the complexity of building design. It shows how different parameters affect several elements of a building design [7]

To describe the processes as objectively as possible the original terms will be used in the following sections although some different terms might mean the same across the different definitions of the IDP method. That will of course depend upon the interpretation of the reader. In some cases the author will write an interpretation in brackets ().

2. Description of three integrated design approaches

2.1. Integrated Design Process. A guideline for sustainable and solar-optimised building design, IEA Task 23 [2]

2.1.1 Motivation and goals for development of the design process

The motivation for developing this method is like mentioned in the introduction to eliminate some of the problems which often occur in a traditional design process. For example possible exposure of the building to high cooling load and expose occupants for discomfort, lack of suitable daylight conditions and limited use of the potential of passive solar heating. This can result in large energy consumption and “added on” features which probably result in a clumsy architecture and maybe a more expensive building than necessary.

The main goal of the process is to be able to design buildings with a markedly higher level of environmental performance. It covers both optimizing the energy performance and for some the full life-cycle performance, all within the constraints of minimal design fees and the time pressure of the modern development process and without compromising the architectural qualities.

2.1.2. Short description of the characteristics of the method

In this IDP the architect is not the only person that makes decisions. All stake holders of the project cooperate across disciplines and agree on decisions together from the beginning. The concept of the energy and building equipment are not designed complementary to the architectural design but as an integral part of the building from the very early design phases. The architects gain knowledge of the technical solutions while the engineers are at the same time gaining in sight into the complexity of the architectural design process.

2.1.3. Key persons or stake holders in the process

In this IDP the client has a more active role than usual. The architect becomes a team leader rather than a sole designer and the different engineers take a more active role earlier in the process. It is possible to have a Design Facilitator (DF) which will manage and have an overview of the process and a core team of architects and engineers. He/she should have a broad knowledge of both architectural and engineering skills and the skills in communication, team management and mediation.

2.1.4. Design Phases

In the following the design phases of the process will be outlined.

Basic: In this phase the team is set-up, where competences and communication qualities are considered. It is essential that the participants are committed and interested in following the process and willing to cross the normal professional boundaries. The first analysis of site, building programme and feasibilities are discussed.

Pre-Design: This phase contains setting up the goal for the project. The client formulates the objectives and the design team must translate these demands into programmatic requirements, performance goals and design criteria (architectural qualities). The site and the climate are explored to find its potential. The projects budget and cost must be set and evaluated during the whole process.

Concept Design: The detailed characteristics of the site are registered and in connection to that a range of designs is developed and constantly investigated and evaluated against requirements, performance goals and objectives. The evaluations should be supported by design assessments and simulations tools. Preliminary building designs are developed, where e.g. concepts of natural light, materials, ventilation and heating is approximated in relation to reliability, flexibility and costs.

Design Development: During this phase the final design (building proposal), its construction principal and materials, sizing of technical installations as well as strategies of solar control, day lighting etc. is found. Detailed drawings, simulations and calculations are evaluated with regard to the requirements and against benchmarks which were identified early in the project including cost demands.

After the Design Development phase the process continues with construction documents, contracting, building execution, supervision, hand-over etc but those will not be presented in this report.

2.1.5. Process development

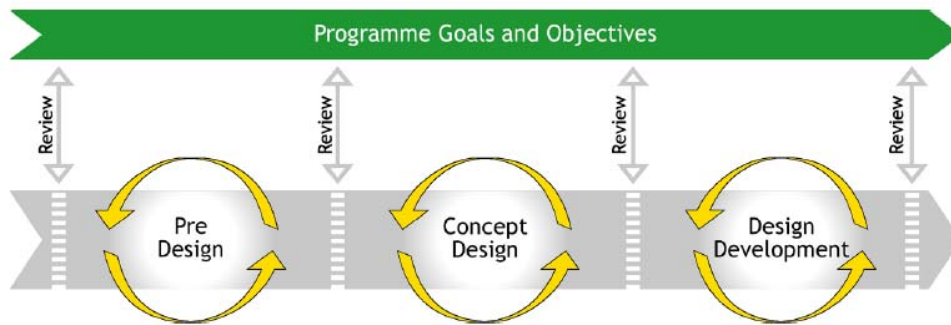


Figure 3: The progress of IDP, Task 23 [2]

The illustration shows in simplified terms the optimal process of the workflow. The circle at each phase illustrates that different designs, calculation and simulation operations are repeated and the process comes closer and closer to next phase and the final design (building proposal).

2.1.6. Design goals/ parameters

The goal-setting involves requirement for quality, environment and cost. Quality involves the use and comfort of the building in terms of light, air and acoustics, thermal performances as well as utilisation quality. Environmental goal involves both life-cycle considerations, energy consumption and use of materials etc.

2.1.7. Tools

The process suggests using various tools to verify and refine the design both in connection to costs and building systems. The designer (the core team) must be aware of the benefits of different tool and when to use them.

In connection to development of this IDP method a tool called Multi-Criteria Decision-Making (MCDM) was developed [8]. The goal for this tool is to help the design team to better understand each other and communicate and take decisions on a common basis. Thereby it can also be used as a weighting of different design proposals, because the tool give an overview of the entire project.

2.1.8. Strengths and weaknesses

Based on the above description and information from literature the following strengths and weaknesses are identified

Strengths	Weaknesses
The method is very well described and many aspects are incorporated. It describes in each phase very detailed how to evaluate goals, quality, environmental and cost issues.	The description of the method is not consistent in its choice of words/terms, it confuses.
The tool MCDM is a very good help to get an overview of the project and for the core team to get a common understanding of the project. It forces you to discuss and define different interests of the project and different terminologies.	Architectural quality is only mentioned once in a section about "Considerations of Design" as a thing to remember in all levels. Could have been more emphasized in the descriptions of each phase because it is actually one of the goals in this process.
The method has been used in practise and has showed satisfying result. See examples below.	Architects belong to the humanistic art tradition and engineers to the technical natural science tradition it can give problems in team work.

2.2.9 Examples

Some good result from the IDP is:

- Office building in Canada, Crestwood 8, in Richmond.
- Bundtland centre in Denmark, in Tofthund

For further detail: http://www.iea-shc.org/task23/download/CS_examples.pdf

2.2. Integrated Design Process –in a problem based learning environment, AAU (AOD) [3] [4]

2.2.1 Motive and goals for development of the design process

This IDP is mainly developed for education at Aalborg University, but can just as well be put into practice. The IDP method is described like

“In this model the traditional architecture and engineering disciplines are split into different components, and some of the components from engineering are combined with the architecture components into a new method. This is what I call the Integrated Design Process. The Integrated Design Process is a synthesis of the pedagogical method (PBL), the students’ personal learning efforts, and the professional learning components from architecture and selected components from engineering.” [3]

Traditionally architects and engineers are not working together, but they are working side by side, meaning that the architects are designing the building proposal and it is then sent back and forth between the architect and engineers, and if the architects can not meet the goals the engineers are designing the services to the building. In the end the building does not necessarily “work well” or the architectural expression is very unclear. Therefore integrating engineering in architecture could help develop better environmental architecture. The students learn to “speak both languages” and work integrated with the IDP method.

The overall goal for this IDP method is to be able to design good environmental buildings with high quality in architectural performances as well as in sustainability (social and economical sustainability) and environmental considerations (a better indoor climate, low energy consumption).

2.2.2. Short description of the characteristics of the method

The process in this method is an iterative process combining architecture, urban and site planning with technical calculations of engineering, thereby covering architectural quality, design, functional aspects, energy consumption, indoor environment, technology and construction. The wish is to get a more holistic building design.

2.2.3. Key persons or stake holders in the process

The students at AOD work primarily in groups which mean that it is possible to have a lot of ideas in the air at the same time and it is possible to have a good and effective workflow. It results in holistic projects where the work field is well searched.

2.2.4. Design phases

In the following the phases of the process will be outlined.

Problem formulation: Description of the project’s idea to an environmental or sustainable building.

Analysis phase: An analysis of the site in connection to sun, wind, landscape and so on and your client’s wishes, building functions, indoor climate, energy consumption, construction etc. Architectural demands are made in a diagram of functions which can give inspiration to the design of the building. It is summarized in a programme which both describes technical and architectural design parameters.

Sketching phase: Through the sketching process the architectural idea and the technical ideas such as principals of construction, energy systems, indoor environment as well as functional demands is tested in relation to each other. Different proposals are continuously evaluated and further developed according to the programme and design parameters.

Synthesis phase: The building finds its final shape through sketches and more calculations and adjustments. Here architectural space and functional qualities, the construction and demands for energy consumption as well as indoor environment flow together. In the end the design parameters have been met.

Presentation phase: The project is presented in a report with text, drawings and visualisations. If the method is used by professionals this phase will be the project design phase.

2.2.5. Process development

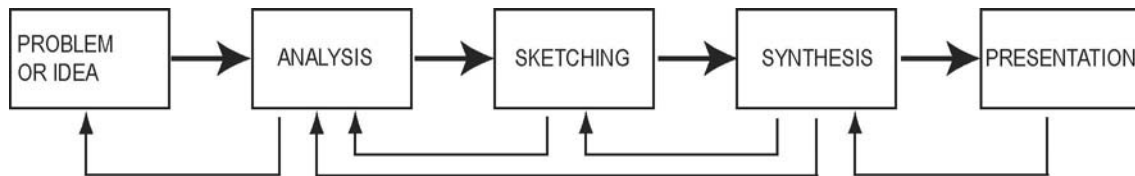


Figure 4: The illustration shows how the process is an iterative process. Sketching, calculations and simulations are done repeatedly and evaluated in connection to the design parameters [3].

2.2.6. Design goals/ parameters

The design parameters describe both technical and architectural requirements. Requirements like energy consumption, indoor environment, and architectural demands like diagram of functions, character of building and wishes for the architectural quality. The big challenge is to describe and get a common understanding in the team of what architectural qualities are in the specific project. The term has been and still is discussed in architectural circles and many have tried to define it. It is not necessarily at static term, it is dependent upon its time and precondition. But it is important to try to get a common understanding of what architectural qualities are, because it is very important in getting a good holistic building in the end.

2.2.7. Tools

To support especially the sketching and synthesis phase it is important to have access to some good tools. Tools that both support the sketching and drawing, analysis of space design in 3D software, calculations of energy consumption, simulation of indoor environment, acoustics and daylight, natural ventilation etc. It is important to be aware of when to use different tools and how to use them. In the sketching phase the tools should be more “sketchy” meaning quick and easy to use without the need of too detailed inputs. As the process develop and the synthesis phase take over the tools can becomes more and more detailed in its inputs.

2.2.8. Strengths and weaknesses

Looking at this IDP as a process for students at AOD, it is a big advantage that they work in groups. It means that all key persons sit together all the time during the process and thereby can an idea quickly be tested or a result can be discussed. In real life the process will of course be more complicated mainly because architects and engineers usually are not located physically in the same house and the cleft between the professions are even bigger. In bigger projects today the engineers and architects are actually moving together in one big office environment close to the building site. In this situation the concepts and ideas can easier be developed together.

Strengths	Weaknesses
Educated at AOD one can facilitate the interaction between architects and engineers in the IDP.	If the method is used in reality it can be difficult for some, especially persons not educated at AOD or other architectural educations, to define architectural quality and make a third party have the same understanding of what it is.
The projects are often much clarified in the synthesis phase both in architectural expression and in technical and passive solutions. It means that frustrating solutions e.g. additional features that could weaken the expression of the building is avoided.	It can for some be difficult to pick up this method because it is a hybrid between a technical engineering approach and the artistic architectural approach.
Takes care of the soft values, like architectural quality which normally is under pressure from the hard facts of engineering. The whole spectrum of parameters is considered at the same time. See a good example below.	As it is today you have to use a lot of different tools for calculating and simulating during the process.
If one has the skills of using this process one has an understanding of both the technical engineering and the artistic architectural language and their rationales.	

2.2.9 Examples



Figure 5: Example of a low energy class 1 single-family house in Denmark –a 9th semester project from AOD, AAU [9]

2.3. Method for integrated design, DTU [5] [6]

2.3.1 Motivation and goals for development of the design process

This IDP definition believes that the other IDP processes can be optimised and made more efficient in the process of developing building proposals.

“Current design approaches tend to be a so-called ‘trail and error’ analysis, where building designs are generated and then assessed in terms of energy performance and indoor environment. The result of the assessment shows whether the specific design fulfils or does not fulfil the established design goals. The distinct risk for rejection of proposed building designs is a distinct risk of wasting time and resources.” [5]

The indoor environment and energy consumption are in many cases dependent of each other and it can be difficult to get an overview of the consequences of a certain design decision. The goal is also to make that more clear and thereby minimize the risk of generating building design which does not fulfil the design goals when assessed.

2.3.2. Short description of the characteristics of the method

This method provides the designers with a certain space of solutions that fulfils the performance goals. Some boundary conditions are outlined and the design (building proposal) can be designed within that. This space of solutions is defined as rooms and/or sections of rooms. It means that the method is working from the inside and out.

2.3.3. Key persons or stake holders in the process

The process is managed by a Design Facilitator (DF) who together with the building owner is the main actors in the process. Then the DF have access to a group of specialist he/she can acquire knowledge from about certain issue.

2.3.4. Design phases

In the following the phases of the process will be outlined.

Step 1: In first step the design goals is set up. The owner’s ideas and wishes are set up by him/her together with the DF. The design goals contains location, type and size of rooms, number of occupant, working hours etc. and performance requirement for the indoor climate and energy consumption. Appendix 1 shows a table where the design goals can be filled-in. In this process the DF has access to a group of specialists; architects and different engineers.

Step 2: In this step possible solutions of rooms that fulfils the design goals are generated by the DF in collaboration with the building owner. The solutions are generated through parameter analysis of a single room of the building. The different solutions are illustrated graphically by 3D image of the room, diagrams showing the energy consumption, level of indoor climate, daylight level, U value, window sizes etc to get an overview of the solutions and possibility of comparing and combining them.

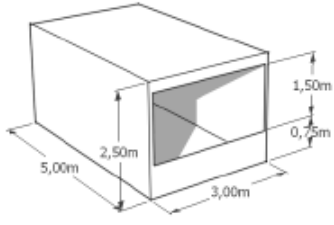
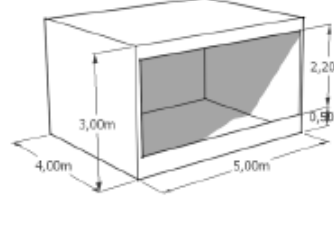
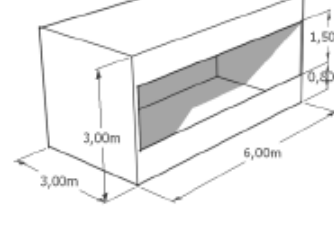
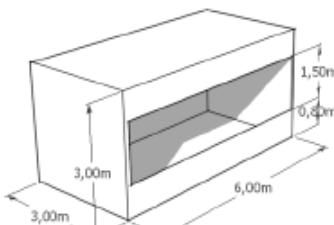
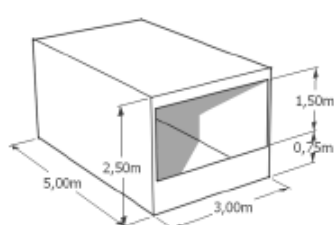
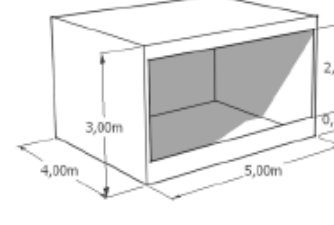
2-person Office		
South	North	East /west
		
ID: Room1.1	ID: Room2.1	ID: Room3.1
		
ID: Room1.2	ID: Room2.2	ID: Room3.2

Figure 6: Example of different space of solutions that fulfils the same design goals [5].

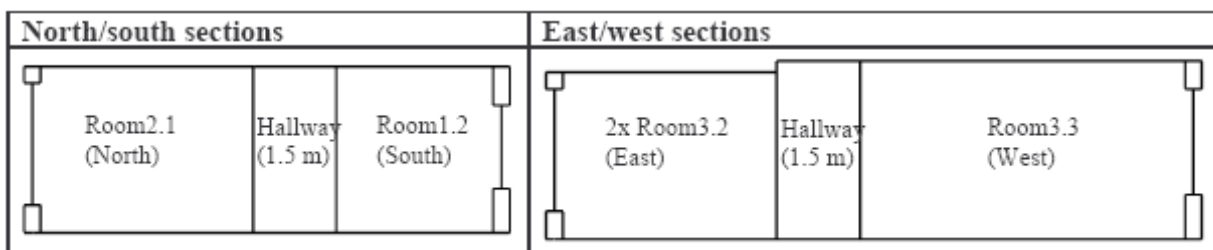


Figure 7: Based on the different solutions of rooms suggestions for sections of the building is produced [5].

Step 3: In step 3 the designs for rooms and sections are combined in a total building design proposal. The key person in this part of the process is the architect. He/she will together with relevant experts freely combine the room and sections in a number of total building designs like building with Lego blocks. It is expected that minor adjustments of the rooms and sections will occur due to the architectural considerations. Step 3 will end with 2-3 different building proposals (see examples in 2.3.9).

Step 4: One final building design has to be selected from the proposed building designs for further detailing. From this IDP's point of view the only distinction between the solutions are small differences in energy and indoor environment performances, the cost and total economy and perception of architectural quality. The procedure is to rank the proposals in connection to the three parameters based mainly on the opinion of the building owner and the final proposal is selected. The final detailing is done after step 4.

2.3.5. Process development

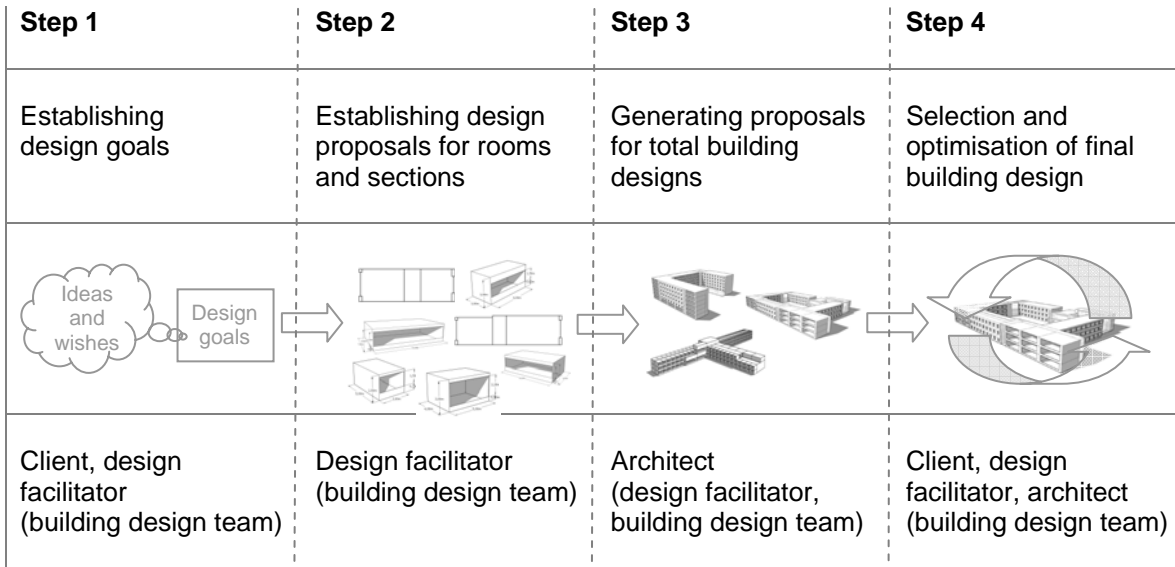


Figure 8: The process incl. key persons in each step [6]

2.3.6. Design goals/ parameters

The main design goals contain quantitative target values for the energy consumption and indoor climate. Additionally location, type and size of rooms, number of occupant, working hours, flexibility etc are defined (see appendix 1).

2.3.7. Tools

In connection to this IDP a tool called iDbuild has been developed. The method and tool is strongly connected. The tool makes it possible to calculate/simulate “all” parameters at the same time on room level; Geometry, building components, systems and energy and indoor data. And it generates the diagrams needed to compare different proposals. It saves you from using a range of different tools to calculate each parameter and thereby save time.

2.3.8. Strengths and weaknesses

Based on the above description and information from literature the following strengths and weaknesses are identified

Strengths	Weaknesses
Problems with communication, which can happen in the cross field of professions, is in the starting phase minimized or eliminated because part of the starting phase only consists of the owner and the DF. It sets up high demands for the DF’s skills in the whole field of engineering and architecture.	The result of the process depend very much of the DF, because one have to know when knowledge from the group of experts is needed. Maybe the DF is not aware of the need for a certain competence because he does not have the competence him self.
The tool iDbuild developed for this IDP method simulate almost all quantitative parameters at the same time. This saves time and money on several calculations tool.	The method simplifies architecture and architectural qualities; it is more than just a shape. It is also materials, texture, poetics of light, function and connections between functions, spatial experiences, lines and directions, colours, spatial experience, urban context etc.
The IDP method and the tool, iDbuild, make sure that the energy consumption and indoor climate always are fulfilled in step 2 and 3.	Uncertain that the process is optimized as what was the main goal of this IDP, because the architectural qualities are not implemented in the design parameters, but implemented later. There is a risk of not fulfilling the technical requirements anyway after “putting on” architecture... (i.e. not resulting in a holistic integrated solution)
A further development of the tool iDbuild could become a very good tool for other IDP definitions as well, because it is very versatile. Especially if more	...if at all possible to implement architectural qualities into the combination of “Lego block”. The rooms you have to combine can have different room

windows and more rooms could be simulated at the same time, but then it might end up being a too complex tool.	heights, window sizes, depth and so on. It might be impossible to make that into one holistic architectural expression.
	When combining the rooms and sections (tried as an exercise at DTU) the focus becomes to solve the “puzzle of rooms” instead of focusing on how the building is going to express it self and be used by the users.
	The simulations in iDbuild are limited to one room with “the best conditions” meaning that the rooms in the corners, against the roof or terrain have worse conditions. It will affect the final and total assessment of the building performance.
	The development of the process tends strongly to be a linier process as TDP, just reversed. The technical parameters are solved in the first steps than the architect have to “put on” the qualities.

2.3.9 Examples

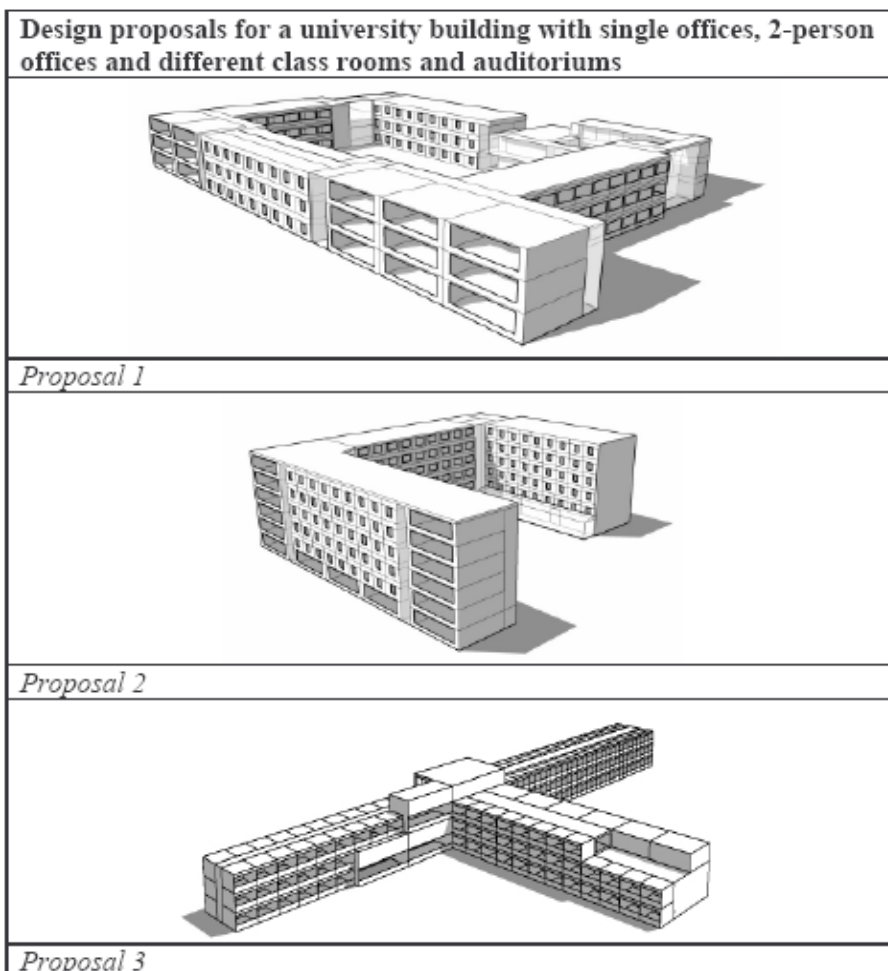


Figure 9: The illustration shows 3 different building proposals based on the same “pool” of rooms. [5]

3. Application experiences of the IDP method by DTU for design of single family houses.

In the following an imagined exercise of designing a single-family house by the IDP method from DTU is described. At the course at DTU the method was mainly discussed in connection to an office building with single offices, double offices and landscape offices. By making an exercise of designing single-family houses, when using the IDP method from DTU, potentials and problems will be outlined in relation to use the method in the Ph.D. study of the author.

3.1 Exercise

In step 1 the owner and DF will define the design goals together, like when designing office buildings. The design goals are illustrated in a table like in appendix 1. A single-family house is more than just a building or a house, it is a dwelling. It is a place that means more to you than just getting a roof over your head. A dwelling is a frame for the personal and emotional life, a place to dwell, feel safe and relax. How that is solved in a house depends very much upon the social and cultural background of the user and the skills of the architect. It varies in each project. The qualitative characteristics of the building are essential demands in designing a dwelling. It is missing in step 1.

The method works at room and section level and that means when designing a dwelling from this method; it needs to be split up in individual type of rooms and giving individual design goals. The need for daylight, fresh air, room sizes and so on will vary according to the function of the room e.g. there are different needs in a kitchen than in a sleeping room.

In step 2 a pond of solutions of rooms which fulfils the design goals for each type of room will be generated. As a parameter in the design goals the orientation would be a help to minimize the amount of solutions of rooms to generate for each type of rooms. Normally one wants a living room to the south, why it would be a waste of time to generate rooms facing north. During the first two steps the DF and owner has access to some specialist like architects and different engineers. Maybe the architect would be a big help in this phase. Because relations between rooms, orientation of room is even more important in a single-family house because as mentioned, it is a place for dwelling and having personal and emotional life.

The tool iDbuild is limiting in different ways. It only simulated one façade turning to the outside, meaning other facades turning outside or surfaces turning to ground or sky are not taken into account in calculating the energy consumption. Because the rooms are boxes it is not possible to simulate rooms with sloping roofs, irregular shapes, having more than one window or skylights; all elements that can supply the dwelling with individuality and quality, which is needed in dwellings today.

In this step some of the rooms are combined in sections and evaluated by the DF and building owner if it is a possible solution for the final building design. A problem could be in this stage that the rooms and sections is understood very literally and might for the building owner be difficult to understand and imaging the outcome. Even a normal drawing of a plan can be difficult for an inexperienced person to understand, were the single boxes of rooms or sections of rooms can be even harder to understand.

In step 3 the room and sections are combined into 2-3 total building designs. Here the key person is the architect. Because a dwelling consists of relatively few rooms the room defined by the DF and owner in step 2, will have very much influence on the expression of the final dwelling. Which rooms can be combined, how can they create a concept of form, facades and plan that both work functional and aesthetically? The combinations have to become good architectural solutions of buildings. Again it depends very much on the DF if this is possible, if he/she and the building owner could generate rooms that can be combined even with its limits. Even if it is allowed to make small adjustment of the rooms and sections it is very difficult to add architectural quality.

In this step it is also important to consider where the technical installations have to run. It is good that their performance and energy consumption are built into the simulation tool, but it is also very important to consider the space and layout of it.

In the end of step 4 the final building design is selected by evaluation the 2-3 different proposals in step 3 by mainly cost, total economy and perception of architectural quality. After that a final detailing of the building can start.

3.2 Summing up the process in the exercise

The author believes that the tool have to be further developed because the tool only simulates one façade turning to the outside, meaning other facades turning to the outside or surfaces turning to ground or sky have to be taken into account in the simulations. One might use another tool to compensate for that but then the process might be even more complex than using another IDP method. Many other tools are not developed to simulate at room level, but developed to simulate at building level, then another IDP method could be just as good.

Especially in a single-family house it is important to think in compact shapes to achieve a low energy building and then it does not necessary make sense to design single-family houses by combining single rooms. There is a risk of combining the rooms into one building which have bigger surfaces than defensible or instead combining rooms into a compact shape but poor of architectural qualities.

The current description of the process is not suitable for designing single family houses. Maybe the method would make a little more sense when designing apartment buildings that could consist of one big open room because each apartment in many cases look the same and can be copied and stacked on top of each other. The problem with the method is again that the tool is simulating the best solution and no taking care of heat losses to the ground, sky and end-rooms/apartments. Observed from an architect's point of view maybe all apartments should not look the same - just be boxes placed on top of each other. Maybe the viewer or user of the building will have a better experience of the city if buildings were more challenging in its look. Some architect firm e.g. PLOT is trying to think more alternatively. How their design methods are is not to be said, but using the IDP method from DTU might not be possible because of its simplified approach to architectural expression.

4) Discussion of different IDP approaches

In the following different definitions of IDP will be discussed in relation to each other.

TDP		Task 23 IDP		AOD IDP		DTU "IDP"	
Phases	Actors	Phases	Actors	Phases	Actors	Phases	Actors
Initiative phase	Client + architect	Basis	Client + core team	Problem formulation	Client + architect with AOD IDP approach	Step 1	Client + DF (access to building design team)
Program phase	Client + architect	Pre-design	Client + core team	Analysis phase	Client + core team		
Design goals/ parameters							
Concept phase	Architect (+client)	Concept-design	Client + core team	Sketching phase	Core team (+client)	Step 2 (Rooms and sections)	DF (access to building design team)
						Step 3 (Proposals for total building)	Architect (DF + building design team)
Project design phase	Architect + engineers (+client)	Design development (Project design phase)	Core team (+client)	Synthesis phase	Core team (+client)	Step 4 (Selection and optimization of final building)	Client + DF + architect (access to building design team)
						Project design phase	
Construction phase							

Figure 10: The table shows how different phases in the different methods correspond to each other and which persons are involved when. It also illustrates how the IDP methods have the common characteristic of setting up design goals. What cannot be seen from this illustration is the length of the phases in the different methods. They will vary according to experience of the players and the type of project. But in general the goal of the IDP methods is to use more time in the beginning and very little in the detailing phase because the project are more clarified earlier because of the integrated work.

The table shows that the process and key persons in the process of the AOD and Task 23 methods are very closely connected. The process contains more or less teamwork through the whole process. The processes

in the TDP have the opposite, a split-up structure of when the key persons are involved. The DTU version stands out because it has one important key person, the DF, who work alone together with the owner in the first two phases and later involve specialists like architects and engineers. The time and resources should be optimized as it is the main goal of this IDP in connection to the other IDP methods, but it depends on how talented the DF is. If the DF is less talented it looks like the DF could take over where the architects are placed in the TDP and the specialist are put in where the engineers normally takes over the detailing. It will be discussed further later.

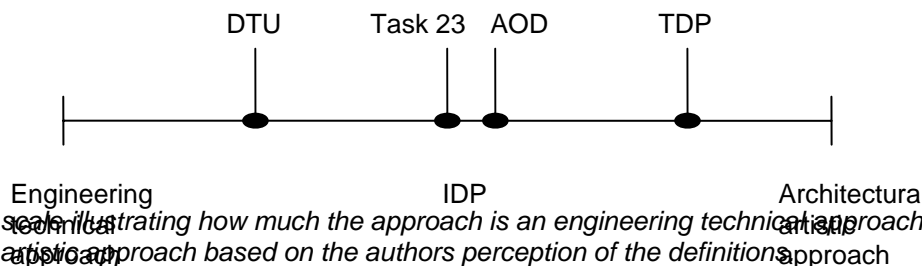


Figure 11: A scale illustrating how much the approach is an engineering technical approach or an architectural approach based on the authors perception of the definitions.

The reason for placing the different IDP methods on a scale as shown in figure 10 is based on the interpretation of the descriptions of the different definitions and the tables with strengths and weaknesses. The two definitions Task 23 and AOD is very much alike. The AOD is placed a little more to the right at the scale, because it focuses very much on the architectural qualities yet still having a big respect for the technical design parameters all through the process. Task 23 is placed more or less in the centre even though it does not focus so much on architectural qualities as AOD in the description of the process, but it has a various of other aspect which the other two methods do not describe. The DTU version on the other hand seems more like an opposite version of TDP. The TDP, as mentioned in the introduction, often solved the technical demands after the architectural expression is decided. The DTU version more or less solves the technical demands first and “put on” the architecture afterwards if that is possible at all. Architecture and architectural qualities is more than just a building shape.

The risk of DTU-IDP being an opposite process of TDP really depends of the design goals and the competences of the DF. To avoid that the design goals need to contain more about the architecture of the building and the DF should be capable of thinking both artistic and technical, and at the same time be able to imagine how the rooms could look like in a combination. Meaning to think forward and image the whole building and only simulate rooms (in iDbuild) which in a combination would be able to contain some level of architectural qualities; e.g. cohesive façade expression, cohesive relation between room heights in the interior and room widths and depths which can define a plan of aesthetics etc. Or else the process might not be optimized which was one of the motives for this process.

Different professions have different perceptions of the same terms; maybe that is one of the reasons why different definition of what an IDP should contain and be structured is developed. One might ask; what is design? What is a design process? And what is integration? All big questions that cannot be answered in this paper, if they can be answered at all.

But the different perceptions of design need a comment. Bryan Lawson describes in “How Designers Think” very well the difference:

“Design´ has become one of those words having such a wide range of references that we can no longer be really certain just what it means. In different contexts the word `design´ can represent such varied situations that the underlying processes appear to share little in common. How is it that an engineer may be said to design a new gearbox for a car while a fashion designer may also be said to design a new dress? The process which gives rise to a new gearbox is surely precise, predetermined, systematic and mathematical in its nature! These are hardly the qualities associated with fashion design, which by contrast, seems rather nebulous, spontaneous, chaotic and imaginative. To make matters even more complicated many kinds of design call for a process which combine both these extremes in varying proportions. Town planning, urban design, architecture, industrial... all involves elements which may seem both precise and nebulous, systematic and chaotic, mathematical and imaginative.”[10]

This quote describes the problems we as architects, engineers and engineers in architecture are facing and trying to optimize by using the IDP. If not working as a team the IDP method end up being defined from only own point of view. The interest of teamwork and crossing our own working area is essential.

5) Conclusion

In optimizing the process of development of sustainable or low energy buildings it might not be necessary to make yet another definition of IDP, but more essential to develop tools that can help the process work flow better. That was also a part of the background for the development of the process from DTU. The tool iDbuild has combined more parameters than other tools, but the tool is still limited in connection to integration of architectural qualities. Therefore DTU should be very careful to introduce their IDP method and tool to the students at DTU. The author is afraid that the teamwork and communication between the architect and the engineers will become even worse than it is today with the TDP. But what DTU has started by developing iDbuild is in the right direction. The important challenge is to develop new software which can be used for making estimations and optimizations of the large numbers of parameters that a IDP process contains –both architectural and engineering parameters; space design, 3D visualisations, building envelope, facades, plan arrangements, functions, logistics and people flow, air flows, materials, energy consumption, daylight level, acoustics, static etc. All in one software, which of course should not be too complex. The biggest challenge is that the inputs should not be too detailed in a phase where the ideas for the building are not so detailed.

In order to be able to work integrated, no matter which method is behind, it is important to be interested in crossing own working area and constantly discuss terms and words to get a common understanding of the definitions. It is necessary both to discuss the more soft architectural terms but also the hard technical terms. To support those discussions architectural and technical references would be a good help. By getting a common understanding, the Integrated Design Process can become even more effective.

6) References

- [1] Directive 2002/91/EC of the European parliament and of the council of 16 December 2002 on the energy consumption of buildings.
- [2] Löhnert G, Dalkowski A, Sutter W (2003) Integrated Design Process. A guideline for sustainable and solar-optimised building design. Austria: International Energy Agency (IEA) Task 23 Optimization of Solar Energy Use in Large Buildings, subtask B.
- [3] Knudstrup, M. (2004) Integrated Design Process in PBL. article in The Aalborg PBL Model, red. Annette Kolmoes, Flemming K. Fink, and Lone Krogh. Aalborg University Press, Denmark.
- [4] Knudstrup, M. (2006) Barriers and Challenges in the Integrated Design Process Approach, Department of Architecture & Design (AOD), Aalborg University /AAU
- [5] Petersen S, Svendsen S (2007) Method for Integrated design. BYG.DTU (Course material)
- [6] Petersen, S. and Svendsen, S. (2008) Method for integrated design of low energy buildings with high quality indoor environment. Proceedings of the 8th symposium of building physics in the Nordic countries. Danish Society of Engineers, Copenhagen. p. 597-604.
- [7]<http://www.dtu.dk/upload/centre/bfi/energirigtigtbyggeri/integrated%20design%20course/space%20of%20solutions.ppt>
- [8] Multi-Criteria Decision-Making (2002) <http://www.iea-shc.org/task23/publications/index.html>
- [9] Brunsgaard, C. (2007) Fremtidens lavenergi typehus. A 9th semester project at Civil Engineering in Architecture & Design, Aalborg University, Denmark.
- [10] Lawson, B. (2006) How Designers Think– the design process demystified by B. Lawson. Architectural Press/Elsevier, Great Britain.

Appendix 1.

1 Type of Building		
1.1 Type		
1.2 Image		
1.3 Floors		
1.4 Site Information	1.4.1 Geographical location	
	1.4.2 Size of site	
	1.4.3 Shadows from surroundings	
2 Use of Building		
2.1 Occupants		
2.2 Number of occupants		
2.3 Space required	2.3.1 Room types	
	2.3.2 Size of rooms	
	2.3.3 Facilities required besides the main rooms	
2.4 Interactions between rooms		
2.5 Flexibility		
2.6 Special equipment required		
2.7 Working hours		
3 Indoor Environment: [fill in room type and size x/y/z]		
3.1 Thermal comfort	Class I, II or III:	
3.2 Lighting		
3.3 Air quality		
3.4 Acoustics		
3.5 Operational comfort		
3 Indoor Environment: [fill in room type and size x/y/z]		
3.1 Thermal comfort	Class I, II or III:	
3.2 Lighting		
3.3 Air quality		
3.4 Acoustics		
3.5 Operational comfort		
4 Energy consumption		
4.1 Energy Frame / Energy Class		
5 Safety		

