



Aalborg Universitet

AALBORG UNIVERSITY
DENMARK

Multimodal approach to sensations from the esophagus in healthy subjects and in patients with gastro-esophageal reflux disease

Korsapati, Hari Prasad Reddy

Publication date:
2008

Document Version
Publisher's PDF, also known as Version of record

[Link to publication from Aalborg University](#)

Citation for published version (APA):

Korsapati, H. P. R. (2008). Multimodal approach to sensations from the esophagus in healthy subjects and in patients with gastro-esophageal reflux disease. Aalborg: Center for Sensory-Motor Interaction (SMI), Department of Health Science and Technology, Aalborg University.

General rights

Copyright and moral rights for the publications made accessible in the public portal are retained by the authors and/or other copyright owners and it is a condition of accessing publications that users recognise and abide by the legal requirements associated with these rights.

- ? Users may download and print one copy of any publication from the public portal for the purpose of private study or research.
- ? You may not further distribute the material or use it for any profit-making activity or commercial gain
- ? You may freely distribute the URL identifying the publication in the public portal ?

Take down policy

If you believe that this document breaches copyright please contact us at vbn@aub.aau.dk providing details, and we will remove access to the work immediately and investigate your claim.

**Multimodal Approach to Sensations from the Esophagus in
Healthy Subjects and in Patients with Gastro-Esophageal
Reflux Disease**

Hariprasada Reddy Korsapati

**CENTER FOR VISCERAL BIOMECHANICS AND PAIN
AALBORG HOSPITAL, DENMARK**

**CENTER FOR SENSORY-MOTOR INTERACTION
AALBORG UNIVERSITY, DENMARK**

**DEPARTMENT OF SURGICAL GASTROENTEROLOGY
ÅRHUS UNIVERSITY HOSPITAL, DENMARK**

2008

ISBN : 978-87-7094-007-8

This thesis is partly based on the papers below, which are referred to in the text by Roman numerals. The studies have been carried out in the period from 2002 – 2005 at the Center for Visceral Biomechanics and Pain, Aalborg Hospital.

I. Drewes AM, Reddy H, Staahl C, Pedersen J, Funch-Jensen P, Arendt-Nielsen L, Gregersen H. Sensory-motor responses to mechanical stimulation of the esophagus after sensitization with acid. *World J Gastroenterol* 2005;11:4367-4374.

II. Reddy H, Arendt-Nielsen L, Staahl C, Pedersen J, Funch-Jensen P, Gregersen H, Drewes AM. Gender differences in pain and biomechanical responses after acid sensitization of the human esophagus. *Dig Dis Sci* 2005;50:2050-2058.

DOI: 10.1007/s10620-005-3006-x

III. Drewes AM, Reddy H, Pedersen J, Funch-Jensen P, Gregersen H, Arendt-Nielsen L. Multimodal pain stimulations in patients with grade B oesophagitis. *Gut* 2006;55:926-932

DOI: 10.1136/gut.2005.067769

IV. Reddy H, Staahl C, Pedersen J, Drewes A, Arendt-Nielsen L, Gregersen H, Funch-Jensen P. Sensory and biomechanical properties of the oesophagus in non-erosive reflux disease. *Scand J Gastroenterology* 2006; 41:640-9

DOI: 10.1080/00365520600973099

CONTENTS

Abbreviations.....	5
Acknowledgements.....	6
1.0 Introduction.....	8
2.0 Hypothesis & Aims.....	10
3.0 Anatomy and physiology of the human esophagus	11
3.1 Sensory innervations of the esophagus.....	12
3.2 Mechanosensitive afferents	13
3.3 Acid sensitive receptors.....	14
3.4 Thermal receptors	15
4.0 Mechanisms of visceral pain	16
5.0 Gender differences.....	17
6.0 Methodological considerations	19
6.1 Experimental pain in gut in humans	19
6.2 Materials	24
6.3 Description of the stimulation and measurement system used in this thesis.....	26
6.4 Biomechanical considerations	29
7.0 Discussion.....	33
8.0 Conclusion	43
9.0 Future perspectives	43
Summary in Danish	45
References.....	47

Abbreviations

ASIC:	Acid-sensing ion channels
AUC:	Area under curve
APSS:	Acid perfusion symptom score
CSA:	Luminal cross-sectional area
GI:	Gastrointestinal
GERD:	Gastro esophageal reflux disease
LES:	Lower esophageal sphincter
NERD:	Non-erosive reflux disease
NCCP:	Non cardiac chest pain
PPI:	Proton pump inhibitor
VAS:	Electronic visual analogue scale.
TRPV1:	Transient receptor potential vanilloid receptor 1
CMR1:	Cold/Menthol receptor
HCL :	Hydrochloric acid

Acknowledgements

Usually, the people who make the greatest sacrifices for academic endeavors are the last ones to be cited last in acknowledgements. In contrast, I shall now break that tradition by mentioning them first. It is important to note, however, that no amount of reward could fully thank them for the sacrifices they have made so that I could explore new boundaries in my career. This included globe trotting with me and allowing themselves to be uprooted from their home, family and friends. I can only conclude that they did it because they love me. Of course, the people to whom I am alluding are my wife Anitha, my daughter Aishwarya and my son Rohan...*Thank you for everything.*

I also owe my most sincere thanks to my principal supervisor professor Asbjørn Drewes, who gave me inspiration and has been a great support through out my employment period and later too. His never failing support to me is the major basis for the work presented in this thesis. Additionally, I would like to express my gratitude to my supervisors Professor Lars Arendt-Nielsen, and Professor Peter Funch-Jensen for their support of the research projects and helpful discussion of the manuscripts.

Much appreciation is also due to Professor Hans Gregersen for the time he expended while meeting with me periodically during his short stay in San Diego to discuss and comment on my research. His input helped me significantly with respect to expediting the process of writing this thesis.

Also from the Center for Visceral Biomechanics and Pain, I would like to thank Jan, Camilla, Jens, George, Barry, Søren, Birgit and Britta as well as all of my healthy volunteers and patients without whom these studies would not even have been possible.

Many of the individuals mentioned above are people with whom I have developed personal friendships. I look forward to these lasting for many years to come.

These projects were Supported by the “Det Obelske Familiefond”, “Spar Nord Fonden” and the Danish Technical Research Council.

Hariprasad Reddy Korsapati, San Diego, January 2007.

1.0 Introduction

Visceral pain is the main symptom prevalent in diseases such as myocardial ischemia, dyspepsia, irritable bowel syndrome (IBS), gastro-esophageal reflux disease (GERD) and non-cardiac chest pain (NCCP). It is a frequent cause of referral for gastroenterological examinations⁽¹⁾. A number of characteristics of visceral pain in contrast to pain from somatic structures are widely appreciated. These include: 1) referral to cutaneous structures, 2) diffuse localization, 3) enhanced autonomic reflexes and 4) cutaneous and deep tissue hyperalgesia^(2, 3)

Consequently, understanding and characterization of gastrointestinal (GI) pain is an important issue in the diagnosis and assessment of organ dysfunction. Research leading to better insight into pain mechanisms in the GI tract will invariably improve the treatment of the patients⁽⁴⁾.

GERD is defined as chronic mucosal damage or typical symptoms, which reduce the quality of life by the abnormal reflux of gastric contents into the esophagus. GERD is very common in the population with up to 30% of the European population reporting heartburn and/or acid regurgitation during the previous 12 months⁽⁵⁾. Recent studies revealed that up to 70% of GERD patients have non-erosive reflux disease (NERD) according to endoscopy. However, in patients with NERD, the quality of life impairment is comparable to that in patients with erosive esophagitis⁽⁶⁾. The symptoms in reflux disease are highly variable and poorly understood. Thus, in patients with GERD, it is clear that no simple relation seems to exist

between the symptoms and severity of the disease ^(7,8). Although treatment with proton pump inhibitors (PPI) is very effective, many patients continue to show symptoms despite treatment ^(9,10). In fact, in one recent study 50% of patients continued to have pathologic reflux despite effective symptom control with PPI ⁽¹¹⁾. Furthermore, it is estimated that 30% - 60% of patients with NERD will have normal ambulatory 24-h esophageal pH monitoring ⁽⁶⁾. Although some of these patients may have reflux of non-acid gastric contents, it is still not clear what causes symptoms in many patients.

Experimental pain methods have contributed to our understanding of the symptoms in reflux disease. In an animal study Garrison et al ⁽¹²⁾ demonstrated that spinal neurons in the cat receiving input from the distal esophagus also received convergent input from the thoracic wall and the heart. It is important to note that when the esophagus was sensitized with turpentine, the neurons responded to a smaller mechanical stimulus from different sites. Such data gives evidence that central mechanisms may explain the symptoms in a substantial proportion of the patients. In humans, however, relatively few studies have been done to explore the pain mechanisms in reflux disease.

Due to the difficulties with access to the organs in the GI tract, experimental pain testing is much more difficult than somatic stimulation. The risk of perforation and other complications also limits the possibilities. Thus, previous studies have typically relied on relatively simple mechanical or electrical stimuli. These methods are easy to utilize, but unless advanced modeling is applied they have several limitations ⁽¹³⁾. Most significantly, as pain is a multidimensional perception, it is obvious that the reaction to a single stimulus of a given modality can represent only a limited fraction of the entire pain experience. By using the multimodal approach, combining different methods to stimulate the gut and evoke hyperalgesia,

we can approximate the clinical situation, and provide more comprehensive and differentiated information about the nociceptive system ⁽¹³⁾.

After this brief introduction, the hypothesis, aims, and background of this study are described in the following sections.

2.0 Hypothesis & Aims

Main Hypothesis:

The general hypothesis behind this work is that GERD patients can be differentiated into disparate groups by applying multimodal stimulations. We also hypothesize that in healthy subjects acid perfusion not only sensitizes the sensory pathways, but also facilitates motor reflexes and gender related differences exist to multimodal stimulations in the esophagus after experimentally induced sensitization.

Overall Objective:

The overall aim of the project was to develop a multimodal approach and, further, to learn more about sensory mechanisms of the esophagus in normal volunteers and in GERD patients.

Specific Aims:

- to investigate the effect on multimodal pain stimulation and of the esophagus as well as sensitization with acid on the sensory response to controlled multimodal stimulation, in healthy volunteers (I), erosive esophagitis patients (III) and NERD patients (IV).
- to evaluate the motor response to this sensitization by a new in vivo method evaluating the change in tension during contraction (the afterload tension) as function of the initial muscle length before the contraction (I).

- to investigate the gender-related differences in pain and biomechanical responses before/after sensitization of the esophagus with acid (II).
- to calculate the evoked referred pain areas to the stimulations in patients and volunteers, which acts as a proxy for the central neuronal changes (I,II,III, IV).

3.0 Anatomy and physiology of the human esophagus

Anatomy

The esophagus is the muscular tube that conveys solid and liquid food matter from the pharynx to the stomach. It is about 20-25 cm in length and tends to a median position as it course through the inferior part of the neck, the thorax and the upper part of the abdomen. It has a neural network in its wall that permits efficient peristaltic swallowing of food boluses and minimizes the potential for reflux ⁽¹⁴⁾. The esophagus, in keeping with the rest of the gastrointestinal tract in which it runs in continuity, has four layers within its wall. These are, from inside to outside:

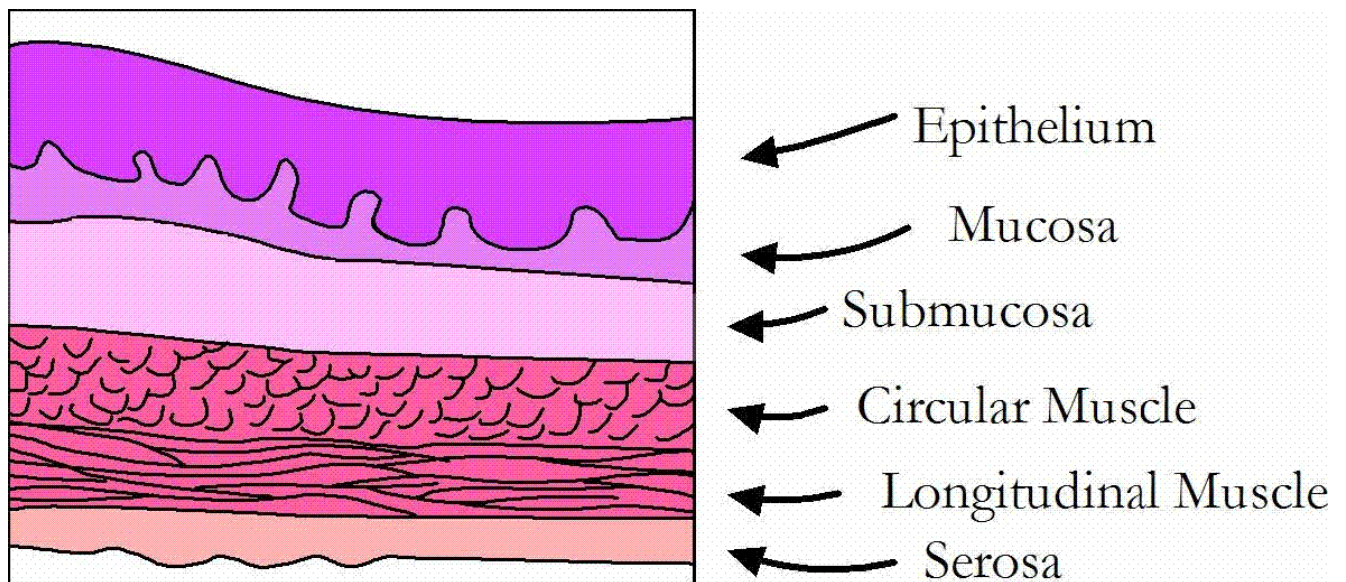

Fig 1: *Cross-section through oesophageal muscle layers shown from inner (mucosa) layer and epithelium layers to outer (serosa) layers.*

3.1 Sensory innervations of the esophagus

The esophagus is dually innervated by the primary sensory afferents that are carried in the vagal and the spinal nerves. The cell bodies of the vagal afferents are located in the nodose and jugular ganglia and those of the spinal afferents are located in thoracic and cervical dorsal root ganglia. Vagal afferents merging from the esophageal smooth muscle layer are sensitive to mechanical distention, whereas polymodal (responding to multiple modalities of stimuli) vagal afferents with receptive fields in the mucosa are sensitive to various osmo-, chemo-, thermo-, and mechanical intraluminal stimuli ⁽¹⁵⁾.

Spinal afferents have their cell bodies in the dorsal root ganglia and they terminate in the spinal column and in the nucleus gracilis and cuneatus in the brainstem. From there, they project, through the thalamus, to primary sensory and insular cortical areas ⁽¹⁶⁾.

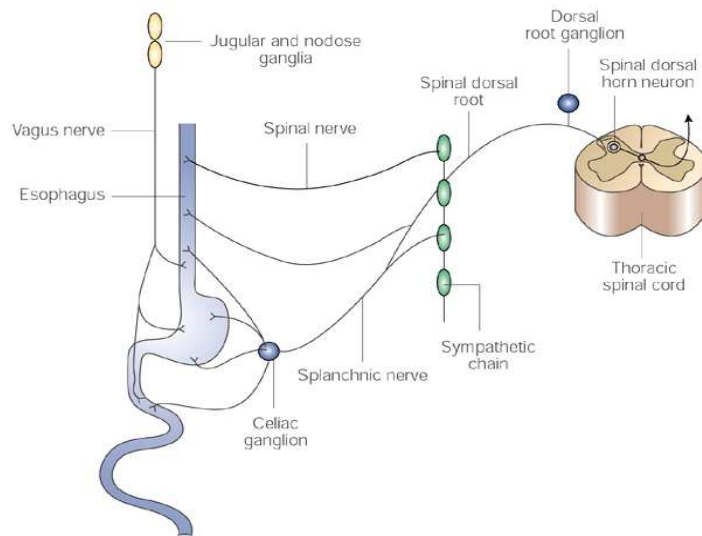

Fig2: Schematic diagram of vagal and spinal nerve supply to the esophagus (adopted from *GI motility online*)

Since it is well known that pain can be elicited in the GI tract using mechanical, thermal and chemical stimuli, the following section describes, in detail, the mechanosensitive afferents, acid sensitive and thermal receptors.

3.2 Mechanosensitive afferents

Vagal mechanoreceptors

Vagal afferent nerve endings are found in both the mucosa and the muscular layer of the esophagus⁽¹⁹⁾. In general, vagal afferents do not play a direct role in visceral pain transmission, but through mechanoreceptors vagal afferents transduce pressure into painful sensations⁽²⁰⁾.

Spinal mechanoreceptors

The spinal afferents merging from nerve endings in the muscle layer and serosa act as nociceptors for perception of discomfort and pain and are mechanosensitive ⁽²¹⁾. The spinal afferents merging from intraepithelial nerve endings in the mucosa are involved in mediating acid-induced pain during topical exposure to intraluminal acid ⁽¹⁸⁾. Many of the spinal afferents contain calcitonin gene-related peptide and substance P, which are neurotransmitters that are important in mediating visceral nociception ^(15,20).

3.3 Acid sensitive receptors

Acid-sensing ion channels

Acid can excite primary sensory afferent fibers in the esophagus by activating two proton-gated channels: transient receptor potential vanilloid receptor-1 (TRPV1) and acid-sensing ion channels (ASICs). The existence of these channels in the vagal and spinal afferents has been documented somewhat extensively in current studies ^(22,23).

Vanilloid receptors

TRPV1 is a polymodal, nonselective calcium-permeable cation channel with six transmembrane domains. The TRPV1 receptor belongs to a transient receptor potential (TRP) channel family of receptors ⁽²⁴⁾. TRPV1 activation occurs with exposure to heat (> 48°C), hydrogen ions ⁽²⁵⁾, and capsaicin. A drop in tissue pH of 5 to 6 leads to VR1 activation ⁽²⁶⁾. Capsaicin, an active ingredient in chilli peppers, is a key activator of TRPV1 and works by lowering the heat threshold required to open the VR1 ion pore ⁽²⁵⁾.

Matthews et al. ⁽²⁷⁾ demonstrated an increase in TRPV1 receptors in the lamina propria of patients who have erosive esophagitis, implying that TRPV1 receptor may be upregulated under reflux disease, the most common condition associated with heartburn. Evidence also suggests that a number of agents (e.g., ethanol, prostaglandins, and others) may sensitize the TRPV1 receptor and induce esophageal symptoms ⁽²⁸⁾. Capsaicin ingested in the meal also lowers the time to postprandial heartburn in patients with GERD ⁽²⁹⁾.

3.4 Thermal receptors

Both experimental studies and clinical observation suggest that there exists a role for the thermal activation of esophageal nociceptive pathways. Patients often identify coffee, tea, and other hot drinks as potential triggers of heartburn. In addition, prior investigations have demonstrated that temperatures of greater than 48°C activate the TRPV1 receptor.⁽²⁵⁾ The TRPV1 receptor may be important to our findings, as it seems to respond both to acid and thermal stimuli ^(30,31) (II,III,IV). Quite notably, capsaicin also activates the receptor and we have recently shown that capsaicin applied to the ileum evoked visceral and referred somatic pain, together with visceral hyperalgesia ^(24,32). The TRPV1 receptor at pH levels under 6 is activated as a polymodal detector of potential harmful stimuli including noxious heat and protons. Our results coincide with the physiological properties of these studies as sensitization with acid did result in a significant change in the sensation to heat stimuli (II, III, IV).

Using a thermal electrode attached to an esophageal probe, Pedersen et al ⁽³³⁾ reported the induction of esophageal pain at both cold temperatures (14°C) and hot temperatures (48.5°C) in healthy volunteers. After acid administration, the threshold to induce heat-related pain was decreased while the referred pain area was increased by 49%. There were no changes in

response to cold pain after perfusion with acid in healthy volunteers (II) and in patients with NERD (IV) or esophagitis (III). This finding is in agreement with some of the most recent studies, which propose that cold receptors constitute a specific population (CMR1 receptors) that can be sensitized with menthol, but not by protons or capsaicin⁽³⁴⁾.

4.0 Mechanisms of visceral pain

Pain from the esophagus usually manifests itself as heartburn and chest pain. These, of course, are manifestations of visceral pain. By definition visceral pain means that it originates from the organs of the thorax, abdomen, and pelvis. Visceral pain is distinguishable from somatic pain in that it is often diffuse and poorly localized.^(35,36) Typically, visceral pain is accompanied by motor and autonomic reflexes such as nausea and vomiting, but somatic pain is not. Also noteworthy is the fact that visceral pain might occur in the absence of actual injury or trauma. Additionally, visceral pain is often referred to areas other than the location of viscera from which it originates. Biliary pain, for example, may be referred to the right shoulder and renal colic to the groin area. Visceral pain tends to be poorly localized because, unlike somatic afferents, visceral afferents exhibit extensive divergence within the central nervous system⁽³⁶⁾. Visceral afferents often travel with somatic afferents from the body wall, which explains why esophageal pain may be referred to the chest wall. The phenomenon of referred visceral pain serves as the basis for secondary allodynia or hyperalgesia.

The degree, to which the referred pain endures and spreads depend on the local gut pain intensity and duration, and hence central summation of the visceral stimulation⁽³⁷⁻³⁹⁾. Various stimulation modalities can also alter the referred pain area. Measurement of the referred pain area is, therefore, of major interest as an indirect measurement of the central activity to gut

afferent stimulation. The patients are typically asked to draw the referred pain area on the skin during or after the stimulation (II, III, and IV). Subsequently, the area can be transferred to a transparent paper and processed for further calculations. Assessment of specific sensibility changes of the skin in the referred pain area is a genuine possibility for the indirect measurement of spinal neuroplastic changes to visceral pain. Hyperalgesia to heat stimulation of the skin was, for example, seen to electrically evoke pain in the stomach ⁽⁴⁰⁾, and such models may improve the knowledge of viscerocutaneous convergence.

5.0 Gender differences

It was one of the aims of this thesis (II) to look further into gender disparities. Experimental visceral pain studies in humans have been contradictory with respect to gender differences (Table 1), and such studies have only to a limited degree been used to explore the gender differences in the visceral organs of healthy subjects.

Subjects	Organ	Method	Extract of main findings
Healthy subjects 11M:11F Pedersen et al.,2004	Esophagus	Polyurethane bag Ramp distensions	No sex differences except larger referred pain areas in females
Healthy Subjects 9M:10F (Nguyen et al., 1995)	Esophagus	Latex balloon with rapid/slow distensions	F had lower pain threshold. No effect of menstrual cycle or body size
Healthy Subjects 42M:57F (Mearadji et al., 2001)	Stomach	Barostat system with stepwise pressure-controlled distensions	Perception of fullness and abdominal pressure increased more rapidly in F,
Healthy Subjects 11M:17F (Sloots et al., 2000)	Rectum	Barostat system with rapid/slow distensions	No difference between gender for first sensation, urge to defecate and maximal tolerated volume
Healthy Subjects 9M:9F (Soffer et al., 2000)	Rectum	Barostat system with stepwise pressure-controlled distensions	No difference between genders for sensation of gas, urge to defecate and pain
Healthy Subjects 13M:15F (Kern et al., 2001)	Rectum	Barostat system with stepwise pressure-controlled distensions	No difference between genders for perception threshold. Painful sensations not evoked. Gender differences in cortical clusters of fMRI activity
Patients with IBS 13M:39F (Ragnarsson et al., 1999)	Rectum	Manovolumetric method with stepwise pressure-controlled distensions	Greater decrease in postprandial pain threshold in women, but no overall gender effect in threshold to maximal tolerable distension level
Patients with IBS 15M:12F (Berman et al., 2000)	Rectum	Latex balloon in the rectum with moderate rectal pressure	No difference in unpleasantness rating to inflation at fixed pressure. PET showed greater blood flow to the insula during the distensions in males
Patients with IBS 31F:28M Healthy subjects 11F:10M Hyun Seo 2005	Rectum	Maximal tolerable pressures were evaluated via barostat tests.	No gender differences in visceral perception were determined to exist between the healthy controls and the IBS patients

Table 1: Previous studies on gender differences along with their main findings

6.0 Methodological considerations

6.1 Experimental pain in gut in humans

The ideal experimental stimulus to elicit gut pain in man should be natural, minimally invasive, and reliable in test-retest experiments and quantifiable ⁽⁴¹⁾. In contrast, most of the research on visceral sensation has used visceral distension (that is mechanical distension) (I) as the stimulus, usually by means of a balloon mounted on a tube that is placed in the viscus of interest and is attached to a distending device such as “impedance planimetry” (I-IV) or a “barostat”. Some studies have even used electrical stimulation while others have investigated chemical stimulation, including but not limited to the utilization of nutrients or acid (I-III). Table 2 outlines the different stimulation modalities and their inherent advantages and limitations.

Stimulation modality	Stimulated structures	advantages	Limitations
Electrical	Nerve fibers primarily in mucosa and muscle layers dependent of the Stimulation intensity (not a specific activation of the nociceptors)	Excellent for repeated stimulation, suitable for neurophysiologic assessments of the pain	The electrical threshold depends on the fiber diameter, i.e. small-diameter nerves cannot be excited without also exciting others. May induce arrhythmias in areas near the heart
Mechanical	Mechanoreceptors located in different layers	Imitates a bolus, reproducible stimulus	Problems with estimating the transmural pressure and change in circumference
Thermal	Thermal sensitive receptors preferentially in the luminal layers	Activation of unmyelinated afferents in the mucosa selectively	Temperature stimuli in the range that can be felt normally only .are relevant for sensation in the upper GI tract.
Chemical	Chemo-sensitive receptors, primarily in the mucaosa	Resembles clinical inflammation, chemical stimuli activate Predominantly unmyelinated C-fibres	Require a relative long latency time to the onset of effects, and that they are often not reproducible when repeated

Table 2. *The different methods for pain stimulation of the human GI tract*

As pain is a multidimensional perception, it is obvious that the reaction to a single stimulus of a given modality can represent only a limited fraction of the entire pain experience. The possibility

for combining different methods for stimulation and assessment will approximate a clinical situation where many different nerves and pathways are activated. Thus, this method will intrinsically provide a more comprehensive and differentiated volume of information about the nociceptive system compared to stimuli using single or a few modalities ⁽⁴²⁾. Consequently, a multimodal testing approach must be used for comprehensive experimental studies mimicking clinical situations. In these, the test battery will increase the probability for activation of a range of relevant nervous mechanisms. Such sophisticated methods will be able to select the best test procedures to explore different basic aspects of pain as well as pharmacological modulations.

Multimodal models have shown their value in somatic pain models, where single modality models have been inadequate to test for example pathophysiological changes and effects of specific drugs ^(43,44). Table 3 describes clinical experimental data obtained using multimodal stimulations. With particular emphasis on situations in which the stimulation includes modalities known to evoke peripheral as well as central sensitization, the likelihood that a model will mimic clinical pain is quite high despite the non-harmful nature of the stimulation ^(43,45). In somatic models, it is possible to provide many different stimuli and to evoke central phenomena (e.g. central integration of summated stimuli) of clinical relevance ^(37,46). However, in the GI tract, difficulties with access to the organs as well as technical limitations of the currently available models have, until now, rendered such a multimodal stimulation approach markedly difficult. Still, some authors have combined mechanical and electrical stimuli ⁽⁴⁷⁻⁴⁹⁾ or mechanical and chemical stimuli ^(50,51) and in a recent study in the esophagus mechanical and electrical stimuli were combined with sensitization to acid ⁽⁵²⁾. In our studies (I, II, III, IV), we have selected the multimodal model with combined mechanical, cold and warmth stimuli of the esophagus together with acid sensitization ^(53,54).

To further improve the multimodal approach, we have adopted acid perfusion intensity scores (APSS) from Fass and coworkers ⁽¹⁸⁾ to measure the chemosensitivity. APSS are calculated from duration of typical symptom perception expressed in seconds and a total sensory intensity rating at the end of acid perfusion using a verbal descriptor scale.

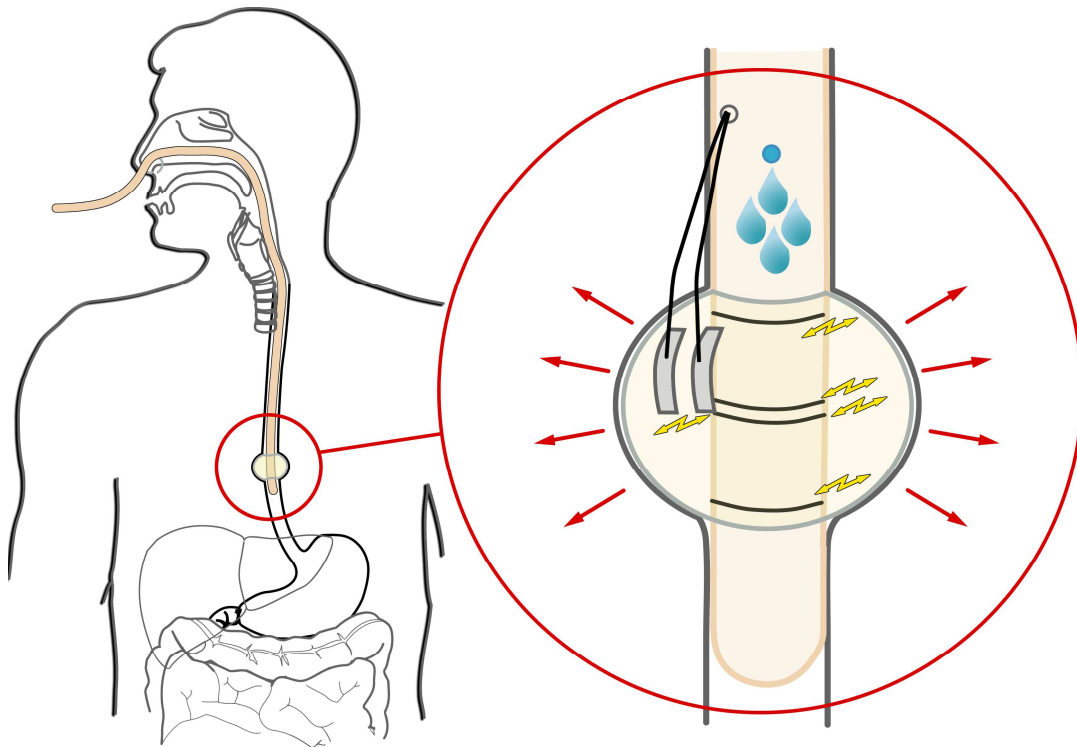

Fig 3: Schematic illustration of the probe used for multi-modal (mechanical, acid, cold and warmth stimuli) stimulations of the esophagus.

The multimodal approach gives the possibility for a differentiated stimulation of receptors in the superficial and deep layers of the gut. The possibility for induction of hyperalgesia with e.g., acid perfusion and evoking central phenomena such as allodynia and referred pain makes the model clinically relevant with respect to increase the knowledge of peripheral and central pain mechanisms (I, II).

	Patient group/healthy volunteers	Main findings
Drewes et al ⁽⁵⁵⁾	Non cardiac chest pain	Increased sensation to mechanical stimulations after acid in patients only
Zhao et al ⁽⁵⁶⁾	Diabetes	Hyposensitivity to distension, but increased referred pain areas, reflecting peripheral neuropathy and central hyperexcitability. Increased stiffness of gut wall in diabetes
Dimcevski et al ⁽⁵⁷⁾	Chronic pancreatitis	No differences in sensation. No differentiated effect on morphine and oxycodone in attenuation of mechanical pain.
Stahl et al ⁽⁵⁸⁾	Healthy volunteers	Oxycodone was better than Morphine and placebo in attenuating mechanical pain. Oxycodone was better than morphine in attenuating heat pain.
Drewes et al ⁽³⁵⁾	Healthy volunteers	Evidence for low and high threshold mechanoreceptors
Drewes et al ⁽⁵⁴⁾	Healthy Volunteers	Mechanical, heat and cold stimuli. Reliability demonstrated Allodynia and hyperalgesia evoked

Table 3: Comparison of clinical experimental data obtained using multimodal stimulations of the gut

6.2 Materials

Table 4 gives an overview of the subjects included in the studies.

Paper	Healthy Volunteers (age)	Patients (age)
I	14 Males and 16 females aged 36.5 ± 12.9 years	
II	13 Males and 17 females aged 38.3 ± 12.4 years	
III	13 Males and 3 females aged 49.7 ± 10.8 years	9 Males and 2 females having grade B esophagitis
IV	7 Males and 8 females aged 44.4 ± 21 years	6 Males and 7 females having NERD

Table 4: *Overview of the subjects included in the studies.*

Selection of volunteers and patients

In all studies healthy volunteers with current GI symptoms, such as heartburn, abdominal pains, nausea, vomiting and with previous surgery in the GI tract, except, appendectomy, herniatomy and uncomplicated cholecystectomy were excluded. Drugs affecting gastric motility and visceral sensation were discontinued at least 48 hours prior to the commencement of investigation. Additionally, each participant fasted for at least 4 hours before investigation.

Eleven patients (nine men and two women) with grade B esophagitis according to the Los Angeles classification ⁽⁵⁹⁾ were included in the study. All patients were recruited from the outpatient clinic at the departments of medical and surgical gastroenterology, Aalborg and Aarhus Hospitals. The mean age was 49.7 ± 10.8 years. All had typical reflux symptoms with heartburn and/or acid regurgitation. The GERD symptoms had lasted for more than three months in all patients, but typically the symptoms were intermittent for several years. All patients were treated with PPIs until 48 hours before the study, but they had no surgical or endoscopic treatments. No patient received any other medication. Apart from the reflux symptoms, they were healthy and, most importantly, had no disorders giving pain.

Patients with recurrent typical GERD symptoms (heartburn and /or regurgitation, symptoms more than 4 days/week and duration more than 6 months) attending our outpatient unit were invited to participate in study IV. At upper gastrointestinal endoscopy, thirteen patients (6 males and 7 females) mean age 44.4 ± 21 did not present any esophageal mucosal injury and were included in the study as having NERD.

6.3 Description of the stimulation and measurement system used in this thesis

The impedance planimetric system

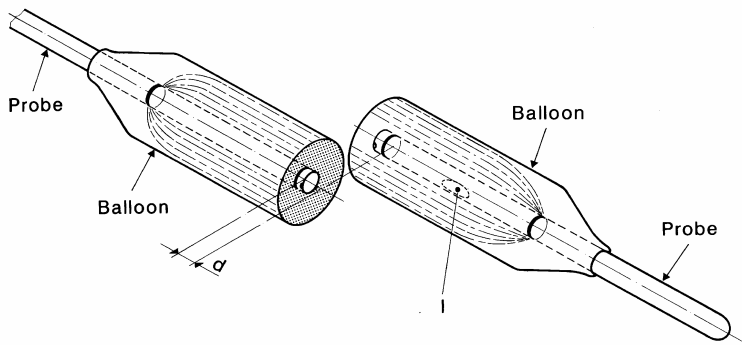

Figure 4: *The impedance planimetric probe for mechanical stimulation of the gastrointestinal tract. "I" and "D" denote the infusion side for filling the balloon and the distance between two detection electrodes.*

The system used in these studies consisted of a four-electrode impedance system, a pressure recorder, an infusion system, a thermometer, acid infusion, a computer, and a monitor for autonomic reactions. Basically, the appearance and design of the probe were quite similar, although there were, indeed, a few subtle differences. In all studies we utilized a 15 F probe that was 70 cm long. In papers I-III we used 50- μm thick, non-conducting polyurethane, because bag leakages occasionally occurred with the thin bag. The size of the bag was chosen on the basis of pilot experiments, which demonstrated that, the luminal cross sectional area (CSA) of the esophagus at the maximum bag volume would not exceed 1200 mm^2 . Thus, reliable

measurement could be carried out in the pathophysiological range without over-stretching the bag wall. Multiple calibration points were used because of the non-linearity between the real and measured CSA. Non-linearity was corrected for up to approximately 1200 mm² by means of software feature (Openlab, Gatehouse, Nørresundby, Denmark). The measurements depend on the temperature and conductivity of the fluid inside the bag, the current, and the distance between the electrodes. To evaluate the influence of such errors on measurement with the probe, both in vitro and in vivo tests were performed. This system was previously validated^(60,61). Since we used a system with fixed electrode distance, constant current and constant solute concentration, these issues were not studied. Regarding the effect of temperature, a 1° decrease would cause a decrease of the CSA with approximately 2 % and 1° increase would cause an increase of the CSA with approximately 2%. To ensure the temperature stability of the infusion fluid during distensions, all infusion tubes and fluid were placed in a digitally controlled heating. Electrically conducting saline (0.09%) was the fluid utilized for distension.

The pressure system

Both probes had pressure channels and the pressure was measured by means of low-compliance perfusion system connected to external transducers. The perfusion rate was 0.1 ml/min. The pressure transducer was calibrated using 0 and 100 cm H₂O as the minimum and maximum.

The thermal system

The thermal system consisted basically of a bag that could be perfused with both cold and warm water and a temperature sensor inside the bag. A 0.2 mm thick thermal electrode was placed inside a separate channel in the probe (Thermoelement type K, Buhl & Bönsö A/S, Virum, Denmark) with the tip placed inside the balloon. The thermal electrode was connected to a transmitter (Universal

transmitter, PR electronics, Rönde, Denmark) which again was connected to the impedance measuring system. Cold and heat pain stimuli were given with re-circulation of 150 ml water in the bag. The probe had two perfusion channels, and the channels were attached to a specially designed manual pump system where water was infused into one channel and simultaneously sucked out in the other channel with a speed of 100 ml/min

Thus, the esophagus was stimulated by thermal conduction. From cutaneous studies we know that the caloric power is dependent on the thickness of the superficial layers, i.e. the mucosa in the esophagus. The stimulus is also dependent on the contact between the bag and the oesophageal mucosa, which is pressure-dependent. In the human esophagus, we could produce stimuli with a fixed volume. Additionally, one should remember that we also could activate low-threshold non-nociceptive nerve fibres that exert an inhibitory effect on pain mechanism or opposite activating high-threshold pain mechanoreceptors amplifying pain.

As mentioned previously in this section, in study II and IV a thermal sensor was placed in the center of probe. The temperature system was tested both in vivo and in vitro. The accuracy of the thermal electrode was approximately $\pm 1^\circ\text{C}$ compared with the surroundings. The thermal probe was calibrated using 5°C and 60°C as minimum and maximum.

The cold and warmth stimuli resulted in a decrease/increase in temperature for approximately 30 sec, after which equilibrium was reached, where the temperature inside the bag was relatively constant. However, the time until the temperature was constant showed individual variation, and all subjects did not tolerate 90 sec at the extreme temperature. Thus, the area under the temperature curve (AUC) when equilibrium was reached, and when the

temperature inside the bag was constantly low/high, was chosen as the most appropriate measure for the caloric load applied to the esophageal wall.

Acid sensitization

Two hundred ml of 0.1 N HCL with a speed of 7 ml/min was perfused in the lower 7 cm of the esophagus for 30 minutes or until the participant reached the pain threshold. If the evoked sensations caused by the acid stimulation were reported to be unpleasant (rated]/5 on the VAS), the perfusion was stopped for 30 s and the subjects were allowed to swallow 10 ml water before proceeding with the perfusion. In the event of the perfusion becoming too unpleasant for the subjects, the procedure was stopped and the amount of infused acid calculated.

Placement of the probe

We used a probe with the following three pressure channels: one inside the bag, one distal, and one proximal for the bag. This way, we identified the lower esophageal sphincter by pull through manometry and then placed the bag 5 cm above the LES.

Safety

During all studies we monitored heart rate for safety reasons.

6.4 Biomechanical considerations

All distensions were basically ramp volume distensions, allowing us to continuously measure the biomechanical and perception score during distensions. This gave us the advantage of being able to

evaluate perception in relation to tissue elastic properties and in a better way than with the staircase distensions that is principally a viscoelastic stimulus ⁽⁶²⁾. Another drawback with staircase distension is that the investigators seldom report the changes during distension before reaching the plateau. Hence, important information about peristalsis, relaxations and contractions and their influence on the sensory response is not provided.

In previous experiments, it was demonstrated that several distensions are necessary to precondition the tissue ⁽⁵³⁾. The preconditioning behavior in soft tissues is a viscoelastic property serving as an adaptive mechanism to increased load ⁽⁶²⁾. This preconditioning is necessary to make the stress–strain relationship during subsequent distensions reproducible. Furthermore, visceral pain is diffuse and difficult to quantify, and the subjects typically need some learning sessions to facilitate the sensory rating ⁽¹³⁾. Hence, to obtain reproducible results, four stimuli with a constant infusion rate of 25 ml/min were done until the subject reported slight to moderate pain (6 – 7 on the visual analogue scale (VAS)). This gave us the advantage of being able to evaluate perception in relation to tissue elastic properties.

Most of the current literature on the esophagus contains data based on balloon distension in humans and in animals with pressure-volume measurements using the barostat system. Principally, we are concerned with the properties in the circumferential direction in tubular organs as the tensile stress in that direction is the most significant. Accordingly, tests based on volume measurements may be less useful since they provide no direct measure of variables useful in plane stress and strain analysis ⁽⁶²⁾. This notion is further supported by the fact that the esophagus is tubular rather than globular. Methods for quantification of the perimeter or two-dimensional measures, such as impedance planimetry or high frequency ultrasound probes, are preferred.

Impedance planimetry is a method that renders possible measurement of the luminal CSA and the balloon pressure thereby measuring the biomechanical properties of the GI tract in any selected plane as a function of infusion volume applied to distend the organ. It permits quantification of the resistance offered by the contractile and the biomechanical properties of the wall and of the sensory responses evoked by the balloon distension. Impedance planimetry has been validated and used for the study of GI function in various animal models and in an increasing amount of human studies ⁽⁶³⁻⁶⁶⁾. Thus, it was advantageous to select impedance planimetry as a primary tool for measuring the biomechanical properties of the human esophagus.

The motor function of the gastrointestinal tract has primarily been studied using manometry and radiography, though more indirect tests have also been applied. Manometry and radiography do not provide detailed information about the muscle properties as can be assessed from studies of muscle properties in muscle strips in vitro. Using impedance planimetric measurement of pressure-cross-sectional area relations in a distending bag has proven to provide more detailed information about the muscle function in vivo.

One way to express the Frank-Starling mechanism in the heart is through the preload-afterload curve. This concept was borrowed from cardiac physiology and it was hypothesized that GI muscle behaves in a similar fashion. The change in tension during individual distension-induced contractions (afterload) was therefore analyzed as function of the radius immediately before the contractions (preload radius).

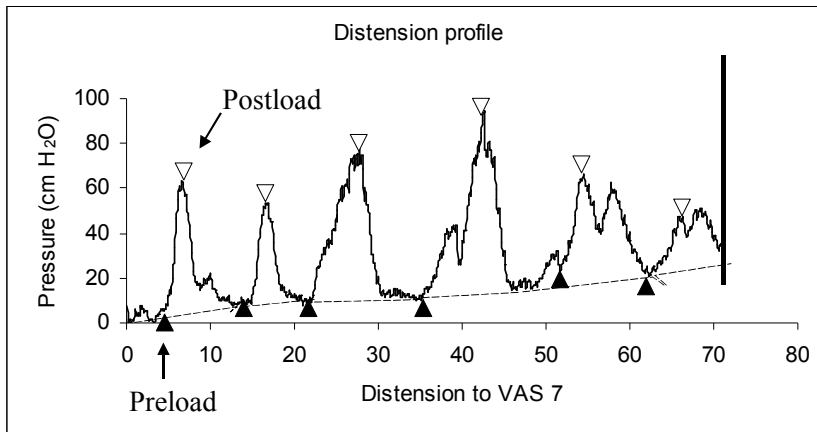

Figure 5: Raw data in a typical subject showing the change in pressure during bag-distension-induced contractions. The change in tension during maximal distension-induced contractions (after load tension) was computed at the open triangles and expressed as a function of the radius immediately before the contractions marked with solid triangles (preload radius). The radius was calculated on the basis of the CSA measured simultaneously.

In cardiac physiology, the preload is usually considered to be the end-diastolic pressure or radius and the afterload is considered to be the arterial pressure during the systole. The explanation of the Frank-Starling mechanism is that when an extra amount of blood flows into the ventricles, the cardiac muscle is stretched to greater length. This causes the muscle to contract with increased force because the actin and myosin filaments are brought to a more nearly optimal degree of interdigitation for force generation.

The importance of the concept of preload and afterload in cardiac physiology is that in many abnormal functional states of the heart and circulation, the pressure during filling of the ventricle or the arterial pressure against which the ventricle must contract, or both, are severely altered from the normal. Transferring this concept to GI physiology, the development may have interest for evaluation of normal GI physiology, aging and in the pathophysiology of GERD,

systemic sclerosis, obstruction, achalasia, functional chest pain contribute significantly to the potential for our future understanding of digestion in health and disease.

The impact of the proposed analysis is to better understand the muscle properties and how they relate to mechanism involved in symptom generation of GERD, non-cardiac chest pain and functional dyspepsia. The perspective is, essentially, that future treatment of GI disorders with affection of neuromuscular pathways can be mechanism- and evidence based with respect to such function curves.

7.0 Discussion

By using a multimodal system, we found:

1. In paper I, the sensory response was assessed in healthy volunteers; before and after sensitization of the lower esophagus by acid perfusion. The sensory rating increased after acid when expressed as a function of the volume, and the degree of sensitization was related to the infused volume of acid. Furthermore, an increase in referred pain to a standardized distension was seen reflecting activation of central facilitatory pain mechanisms. The mechanical analysis demonstrated hyper-reactivity of the esophagus following acid perfusion, with an increased number and force of the phasic contractions, but the muscle tone did not change. This illustrates that acid perfusion not only sensitizes the sensory pathways, but also facilitates motor reflexes.

2. In paper II, males were more sensitive to mechanical esophageal stimuli and tolerated less acid perfusion of the esophagus. After acid perfusion they were more sensitized to the infused bag volume. In contrast, females had increased referred pain area to the heat stimulations following acid perfusion. Therefore, we suggest that the central inhibition in females is less solid

than it is in males. This may explain the female predominance in many functional disorders. Finally, there were no gender differences in the acid-evoked sensitization to heat and hyperreactivity of the esophagus. These findings suggest that gender differences to multimodal stimulation of the esophagus are complex and highly modality specific.

3. In paper III, patients with grade B esophagitis had hyposensitivity to the infused volume of the bag and showed an increased number of distension induced contractions, but had hyperalgesia to heat and increased/widespread referred pain to the mechanical stimuli. We believe that the acid reflux in vivo specifically sensitizes heat receptors in the mucosa and evokes central changes reflected in the referred pain pattern. These observations are consistent with experimental studies using short lasting acid perfusion of the distal esophagus in healthy volunteers, and may be important in our understanding of the pain mechanisms in patients with erosive reflux disease.

4. In paper IV, we hypothesized that NERD patients had esophageal hypersensitivity. Correspondingly, our data evidenced the fact that those patients had hyperalgesia to heat stimulation. Furthermore, the patients exhibited increased referred pain areas for both mechanical and heat stimulation. The NERD patients also had more distension-induced contractions as we observed the same in paper I.

Effect of sensitization with acid in healthy volunteers

Increased responses to mechanical, electrical and thermal stimuli after acid perfusion of the esophagus have previously been demonstrated in human beings^(51,52,54,67). It is important to note, however, that previous studies using latex balloons were not consistent. This can be due to

methodological problems using latex balloons, where the distension data must be corrected for the intrinsic mechanical properties of the balloons and for the uncontrollable deformation in longitudinal direction^(51,62). Non-compliant polyester urethane bags overcome these problems. The effect of preconditioning the tissue by several distensions until the stress-strain relationship becomes reproducible has also not been considered in most previous studies^(13,68). Different modifications of the acid perfusion test have been used as a chemogenic stimulus by several authors^(18,50-52,67). When the current material (II) was divided into those who tolerated below and above 100 ml of acid, significant increased sensation to the mechanical stimulus was only seen in the high acid group. Therefore, we recommended that volumes greater than 100 ml be utilized in future studies.

After acid infusion, the esophagus exhibited hyper-reactivity as illustrated by the increased number of contractions after the acid perfusion. Such hyper-reactivity has also been seen in animal studies^(69,70). The contractions were also stronger to a given preload radius. However, the acid infusion did not change the total tonic tension, the passive tension and the active tonic tensions. Hence, the hyper-reactivity only accounts for phasic contractions, not for tone in the esophageal body. Previously, Sifrim et al.⁽⁷¹⁾ showed that acid reflux into the esophagus stimulated tone in the esophageal body. However, simultaneous distension seemed to inhibit the acid induced tone. These issues obviously need further investigations. The preload radius where contractions were evoked by the painful stimuli (VAS = 5 and higher) did not change after acid. This finding may correspond with the “strain theory”, i.e., which suggests that the mechanoreceptors are activated by circumferential stretch independent of the contractile state of the muscles^(64,72,73).

Gender differences

Experimental visceral pain studies in humans have been contradictory with respect to gender differences and such studies have, only to a limited degree, been used to explore the gender differences that may exist in the visceral organs in healthy subjects. A lower pain threshold to esophageal distension was demonstrated in females⁽⁷⁴⁾ whereas rectal studies showed no gender differences in the mechanical thresholds⁽⁷⁵⁻⁷⁷⁾. Methodological problems may, to some degree, explain these contradictory findings. Additionally, as in somatic pain studies, the use of a single stimulus modality may be insufficient to show an effect on the viscera^(78,79).

The multimodal probe was used to investigate any differences to mechanical and thermal stimuli of the esophagus (II). The results were somewhat ambiguous, but in general, males appear to be more sensitive to the stimuli. However, a greater size of the referred pain areas to the different stimuli was seen in women. After acid perfusion, the males were also more sensitive than females to distensions, but no differences were found in response to the thermal stimuli. In the females, only the referred pain area was increased to heat stimulations after sensitization with acid. Consequently, it can be decided that the bigger referred pain areas may reflect that the central processing of pain to visceral stimuli differs between males and females as previously shown by our group and also by Kern et al⁽⁷⁷⁾. Thus, the multimodal stimulations revealed a differentiated response to peripheral and central pain mechanisms, which may explain the sex-related differences seen in several gastrointestinal diseases.

Erosive reflux disease

Patients with erosive disease of the esophagus may have a more severe disease than NERD patients, although erosive disease may also be a distinct entity⁽⁸⁰⁾. In a study comparing patients

with esophagitis with controls, Fass et al ⁽¹⁸⁾ demonstrated enhanced perception to acid perfusion, but the response to mechanical stimulation was normal. Such findings may point towards a differential effect on mechano-sensitive and chemo-sensitive pathways in esophagitis. The patients with grade B esophagitis (III) had hyposensitivity to the mechanical stimulations, but had hyperalgesia to heat. These findings were comparable to those in NERD patients (IV) with abnormal pH profiles and they may also indicate that the pain mechanisms could be the same whenever erosions occur or not. A recent paper suggested that abnormal tissue resistance to acid may explain both the hyperalgesia and motor abnormalities seen in many patients with GERD and NERD ⁽⁸¹⁾. Patients showed hyperalgesia to heat (but not cold) stimuli (IV). We believe that VR1 receptors sensitized by the acid reflux are important, and VR1 receptors have recently been shown to be up-regulated in esophagitis ⁽²⁷⁾.

Central pain mechanisms

Central changes are also believed to be important in erosive disease. Although Fass et al ⁽¹⁸⁾ found a normal location of the referred pain; we recently showed that the size of the referred pain area was larger than in controls. Thus, there exists substantial evidence demonstrating that exposure of acid in the esophagus in patients with esophagitis results in central neuroplastic changes. One can speculate that the reason for specific hyposensitivity to mechanical stimulations in patients with erosive disease may be related to well functioning counter-regulatory neural mechanisms acting from the brain stem at the spinal cord level. These may prevent the development of long-lasting sensitization of mechanosensitive afferent pathways ⁽¹⁷⁾. The central pain modulating systems rely on a balance between facilitatory and inhibitory

descending pathways and intrinsic spinal circuits and it is not predictable in the individual patient^(82,83).

Studies conducted on animals have repeatedly shown that the system is an important mechanism in the modulation of visceral stimuli⁽⁸⁴⁾ and that these neuroplastic changes may result in increased referred pain on the one hand and dampening of the activity from mechanosensitive pathways on the other. In general, chronic tissue injury and pain has been associated with higher thresholds to mechanical stimulation in different regions of the gastrointestinal tract. For example, chronic inflammation of the small bowel⁽⁸⁵⁾ in patients with inflammatory bowel disease is not associated with mechanical hyperalgesia of the rectum. This is contrasted with the pain in functional visceral disorders where hyperalgesia and allodynia to mechanical stimuli of the gut are typically found⁽⁸⁵⁻⁸⁸⁾. Hence, it can be speculated that a difference in the balance between noxious control systems arising in the brainstem may explain the findings prevalent in the different patient groups.

Non-erosive reflux disease

Assessment of mechanosensitivity using intra-esophageal balloon distension has yielded contradictory results. In NERD patients, Rodriguez-Stanley et al⁽⁸⁹⁾ reported a decrease in sensation and pain thresholds to distension compared with an historic control group. Trimble et al⁽⁹⁰⁾ studied NERD patients without excessive reflux and found that these patients were most sensitive to esophageal balloon distension, whereas patients with excessive reflux had a level of sensitivity similar to that of healthy control subjects. In another study using esophageal balloon distension delivered by an electronic barostat, patients with NERD and patients with erosive esophagitis did not demonstrate an increase in mechanosensitivity when compared to normal

controls ⁽¹⁸⁾. The previous experimental pain studies used mechanical stimulations based on recording of volume and pressure. These studies may lead to errors relating to the deformation field and erroneous conclusions ⁽⁷²⁾. It has been suggested that chronic esophageal exposure to excess acid affects chemosensitive but does not affect mechanosensitive afferent pathways ⁽¹⁸⁾ and that the key abnormality in NERD patients is that they are hypersensitive to acid reflux. Our data (IV) showed that the patients had hyperalgesia to heat stimulation, whereas they were hyposensitive to mechanical stimulations. There was, however, a difference in the NERD subgroups as patients with a pathological pH profile exhibited hyposensitivity to mechanical stimulations compared to both controls and patients with normal pH monitoring. Taken together with the above findings, these results reflect that patients with pathological acid reflux may be less sensitive to mechanical stimulation and more sensitive to heat. The selective sensitization to heat may be related to specific receptor activation. In paper I, we showed that acid perfusion of the esophagus in healthy subjects differentially sensitizes the esophagus to heat, but not cold stimuli ⁽³³⁾. The VRI receptor may be important to our findings. The receptor can be activated by a variety of stimuli, including acid (protons) and increases in temperature that reach the noxious range. Thus, it can be hypothesized that in patients with NERD the acid reflux and resulting peripheral sensitization results in a significant change in the sensation to heat stimuli working on the same receptor as the acid. Further studies are needed in order to explore whether the VRI receptors are up-regulated as seen in patients with erosive disease of the esophagus ⁽²⁷⁾.

In the studies (III, IV), we also found an increase in the referred pain areas for both mechanical and heat stimulation in esophagitis and NERD patients. Acid perfusion of the distal esophagus in healthy subjects resulted in an increase in the referred pain area to differentiated esophageal stimuli (I, II). This is most likely related to central neuronal hyperexcitability after

acid perfusion, and to the subsequent opening of latent connections between converging neurons from visceral and somatic structures in the central nervous system ⁽⁹¹⁾. Thus, the larger and widespread localization of the referred pain area is thought to represent central hyperexcitability. Consistent with these findings, Penagini et al ⁽⁹²⁾ showed that patients with NERD had increased sensitivity to distension of the proximal stomach. This viscerovisceral hyperalgesia is also considered a central phenomenon ⁽⁹³⁾. Experimental acid perfusion of the esophagus in healthy subjects has also been shown to increase the amplitude of the polysynaptic nociceptive reflex working at the spinal level ⁽⁵⁴⁾. Sarkar et al, ^(52,94) demonstrated that acid perfusion of the distal esophagus resulted in allodynia and shorter latencies of the evoked brain potentials to electrical stimulation of a more proximal segment of the esophagus. Accordingly, our group recently found a backward shift in the early activity in the cingulate gyrus to esophageal pain stimuli after acid perfusion of the organ ⁽⁹⁵⁾. Thus, there exists substantial evidence suggesting that exposure of acid in the esophagus (such as in some NERD patients) may result in central neuroplastic changes at spinal and supraspinal levels.

Comparison with NCCP

If the patients describe “heartburn” and “acid regurgitation,” they are typically classified as having GERD. However, burning pain may also be evoked by e.g., experimental distension or electrical stimulation of the stomach ⁽⁴⁰⁾ and the value of the subjective description of chest pain is up to discussion. GERD is also the most frequent cause of NCCP ^(96,97). However, in this case the chest

pain is no longer unexplained and the overlap invalids the diagnostic criteria for NCCP. Thus, it is important to differentiate NCCP patients from GERD patients.

In a recent study ⁽⁹⁸⁾ conducted by our group, we distended the distal esophagus in patients with NCCP before and after sensitization with acid using multimodal approach. Patients with NCCP did not seem to be more vulnerable to develop esophageal hyperalgesia to the slowly increasing mechanical distensions as compared to controls before acid perfusion. However, there was evidence for abnormal central pain processing as there was an increased and widespread referred pain area to the mechanical stimulations and the patients were sensitive to repeated mechanical stimulation. Furthermore, after acid perfusion (believed to evoke hyperexcitability of central pathways mainly) there was a major sensitization to the distensions. Thus, it was concluded that NCCP patients showed facilitated central pain mechanisms, which may explain the character of their symptoms.

By applying the multimodal stimulations, we have shown that it is possible to differentiate GERD into several groups. However, because of the small number of subjects, we have not explored the differences between NERD patients with normal and pathological 24-pH measurement in detail (IV). It may also be possible to distinguish among the different groups of GERD patients and differentiate them from NCCP patients depending on the response to multimodal stimulation (Table 5).

NERD patients with pathological 24-h pH measurement are very much like those with erosive disease, and NERD patients with normal acid reflux are likely comparable to those with NCCP. Abnormal activation and plastic changes of central pain pathways seem to play a major role

in the symptoms in NERD patients with normal pH measurement and in patients with functional chest pain of esophageal origin. On the other hand, in patients with erosive disease or NERD with pathological 24-h pH measurement, sensitization of heat sensitive receptors and pathways combined with facilitation of central pain mechanisms may explain the symptoms. These findings may lead to an alternative approach for treatment in those patients that do not respond to conventional medical or surgical therapy.

	Esophagitis	pathological 24h-pH measurement positive	Normal Acid reflux (24h- pH measurement negative)	NCCP
Mechanical stimulation	Hyposensitive	Hyposensitive	No differences	No differences Hypersensitive after Acid infusion
Thermal stimulation				
Heat	Hyperalgesia	Hyperalgesia	Hyperalgesia	Not done
Cold	No difference	No difference	No difference	Not done
Referred pain areas	increased	increased	Increased	Increased
Reactivity	Hyperreactivity	Hyperreactivity	Hyperreactivity	Not Done
Repeated distensions	Not done	Not done	Not done	Tolerated smaller number than Healthy volunteers
APSS	Not done	increased	increased	Not done

Table 5: Responses to multimodal stimulations to different groups of GERD and NCCP. NERD patients with pathological 24-h pH measurement are very like those with erosive disease, and those with normal acid reflux are comparable to those with NCCP. APSS measures the chemosensitivity.

8.0 Conclusion

Pain is the most prevalent symptom in gastroenterology but yet poorly understood. This is reflected in the treatment of visceral pain that is often very difficult and highly challenging. We have used multimodal methods to evoke and assess experimental pain in the GI tract to explain the pain mechanisms in health and GERD. For the first time we have applied Frank-Starling mechanism to the GI muscle after sensitizing with acid and also found gender differences to acid sensitization.

Abnormal activation and plastic changes of central pain pathways seem to play a major role in pH negative NERD (and NCCP) patients. We found subtle differences in different groups of the GERD by applying multimodal stimulations. However, there are no gross differences and at this stage cannot be used clinically to segregate GERD into different groups. However, we believe that by improving the technique, methods, and by increasing the number of subjects, that it would be possible to discover even more disparities.

9.0 Future perspectives

This thesis considers the oesophageal biomechanical properties and sensory responses in healthy subjects (I, II), patients with non-erosive reflux disease (IV) and patients with esophagitis (III) using a multimodal pain stimulation approach. The effect of acid sensitization was studied, focusing towards the sensory responses (I). Furthermore, this thesis examines differentiated responses to peripheral and central pain mechanisms that may explain the sex related differences seen in several gastrointestinal disorders (II). Finally, the multimodal method was used to examine the sensory response in patients with erosive (III) and non-erosive GERD (IV). The multimodal probe can be further improved to be used clinically as diagnostic tool in order to differentiate among the various

groups of the GERD. Electronics and material sciences can be improved for a better design. Multimodal stimulations can be used for Phase II trials where the experimental methods are used to evaluate the drugs will be a feasible way to obtain more knowledge, before more expensive large scale phase III studies in the clinic are initiated. This technology can be applied to gain more insight into basic peripheral and central pain mechanisms as well as characterizing patients with different diseases of the GI tract.

Summary in Danish

Symptomer og sygdomme stammende fra oesophagus er særdeles hyppige i befolkningen. Eksempelvis er prævalensen af symptomgivende gastro-oesophageal reflux i den vestlige verden mellem 10 og 15%. Baggrunden for disse symptomer er imidlertid dårligt belyst. I aktuelle afhandling blev der opstillet eksperimentelle modeller af oesophagus sensoriske og motoriske funktion, og disse blev anvendt hos raske såvel som hos patienter med enten erosiv eller ikke-erosiv reflukssygdom.

I studierne på de raske forsøgspersoner undersøgte oesophagus før og efter eksperimentel syreeksponering. Man kunne vise at syreeksponering øgede det sensoriske respons ved at fremkalde såvel perifer hyperalgesi som hyperexcitabilitet i centralnervesystemet. Desuden viste avancerede beregninger af muskelfunktionen, at de fasiske kontraktioner blev øget i styrke, hvorimod tonus i spiserøret var uændret. I det næste studie undersøgte det, om der var kønsforskelle ved syreeksponering hos raske personer. Modsat den gængse opfattelse var mænd mere følsomme ved mekaniske og kemiske stimuli af oesophagus. På den anden side var det meddelte smerteområde større hos kvinderne. Da man formoder at den descenderende smertehæmning fra højere hjernecentre er mindre udtalt hos kvinder, kan dette måske forklare fundene. Desuden kan sådanne studier medvirke til at forklare, hvorfor ”funktionelle” gastrointestinale som bl.a. karakteriseres ved abnorme meddelte smerter er hyppigere hos kvinder end mænd.

I patientstudierne undersøgte man patienter med reflukssygdom med og uden erosive forandringer i oesophagus. Patienterne med erosiv sygdom var karakteriseret ved en selektiv hyperalgesi overfor varmestimuli, hvilket indikerer at specifikke receptorsystemer (TRPV1) er blevet aktiveret af den excessive syrefluks. Desuden fandtes der tegn til at det perifere stimulus havde aktiveret mekanismer i det centrale nervesystem, idet patienterne havde større meddelt

smerteområde end kontrollerne. Hos patienter med ikke-erosiv reflukssygdom så man også selektiv hypersensitivitet ved varmestimuli samt et øget meddelt smerteområde. Disse patienters smerteaktivering ligner således den, man ser ved erosiv sygdom. Patienterne kunne klassificeres, afhængigt af om 24-timers pH-målingen var normal eller ej. Ved denne opdeling fandt man, at dem med patologisk reflux mere lignede patienter med erosiv sygdom med bl.a. hyposensitivitet overfor mekaniske stimuli. Derimod var mekanismer som blev anset for at være ”centrale” (antallet af sekundære kontraktioner samt det meddelte smerteområde) størst hos patienter uden patologisk syreflux. Dette tyder på at der er forskellige subpopulationer af disse patienter, hvilket vil blive undersøgt i fremtidige studier.

References

1. Kimmy MB, Silverstein FE. Diseases of the gastrointestinal tract. In: Bonica JJ, ed. The management of pain. Philadelphia: Lea and Febiger, 1990:1186-1213.
2. Cervero F. Visceral pain. In: Dubner R, Gebhart GF and Bond MR, eds. Pain Research and Clinical Management, Proceedings of the 5th World Congress on Pain. Amsterdam: Elsevier, 1988:216-226.
3. Ness TJ, Gebhart GF. Visceral pain: a review of experimental studies. Pain 1990;41:167-234.
4. Bochus HL. Abdominal Pain. In: Berk JE, ed. Gastroenterology. Philadelphia: WB Saunders, 1985:22-47.
5. Mahmood Z, McNamara D. Gastro-oesophageal reflux disease and ulcer disease. Alimentary Pharmacology & Therapeutics 2003;18 Suppl 3:31-37.
6. Labenz J, Malfertheiner P. Treatment of uncomplicated reflux disease. World journal of gastroenterology : WJG 2005;11:4291-4299.
7. Fass R, Tougas G. Functional heartburn: the stimulus, the pain, and the brain. Gut 2002;51:885-892.
8. Okamoto K, Iwakiri R, Mori M, Hara M, Oda K, Danjo A, Ootani A, Sakata H, Fujimoto K. Clinical symptoms in endoscopic reflux esophagitis: evaluation in 8031 adult subjects. Digestive diseases and sciences 2003;48:2237-2241.
9. Carlsson R, Dent J, Bolling-Sternevald E, Johnsson F, Junghard O, Lauritsen K, Riley S, Lundell L. The usefulness of a structured questionnaire in the assessment of symptomatic gastroesophageal reflux disease. Scandinavian journal of gastroenterology 1998;33:1023-1029.
10. Bytzer P. Goals of therapy and guidelines for treatment success in symptomatic gastroesophageal reflux disease patients. The American Journal of Gastroenterology 2003;98:S31-9.
11. Milkes D, Gerson LB, Triadafilopoulos G. Complete elimination of reflux symptoms does not guarantee normalization of intraesophageal and intragastric pH in patients with gastroesophageal reflux disease (GERD). The American Journal of Gastroenterology 2004;99:991-996.

12. Garrison DW, Chandler MJ, Foreman RD. Viscerosomatic Convergence Onto Feline Spinal Neurons from Esophagus, Heart and Somatic Fields - Effects of Inflammation. *Pain* 1992;49:373-382.
13. Drewes AM, Gregersen H, Arendt-Nielsen L. Experimental pain in gastroenterology: A reappraisal of human studies. *Scand J Gastroenterol* 2003;38:1115-1130.
14. Long JD, Orlando RC. Anatomy, histology, embryology, and developmental abnormalities of the esophagus. In: Feldman M, Fieldman LS, Sleisenger MH, eds. *Gastrointestinal and Liver Diseases*. Philadelphia: WB Saunders, In: Anonymous 2002:551-560.
15. Fass R. Sensory testing of the esophagus. *Journal of clinical gastroenterology* 2004;38:628-641.
16. Aziz Q, Thompson DG. Brain-gut axis in health and disease. *Gastroenterology* 1998;114:559-578.
17. Mayer EA, Gebhart GF. Basic and clinical aspects of visceral hyperalgesia. *Gastroenterology* 1994;107:271-293.
18. Fass R, Naliboff B, Higa L, Johnson C, Kodner A, Munakata J, Ngo J, Mayer EA. Differential effect of long-term esophageal acid exposure on mechanosensitivity and chemosensitivity in humans 1. *Gastroenterology* 1998;115:1363-1373.
19. Sengupta JN, Gebhart GF. Mechanosensitive afferent fibers in the gastrointestinal and lower urinary tracts. In: Gebhart GF, ed. *Visceral Pain. Progress in Pain Research and Management*. Seattle: IASP Press, 1995:75-98.
20. Goyal R, Sivarao D. Functional anatomy and physiology of swallowing and esophageal motility. In: Catell OD, Richter JE, eds. *The Esophagus*, 3rd ed. Philadelphia: Lippincott Williams & Wilkins, 1999.
21. Mayer EA, Gebhart GF. Basic and clinical aspects of visceral hyperalgesia. *Gastroenterology* 1994;107:271-293.
22. Patterson LM, Zheng H, Ward SM, Berthoud HR. Vanilloid receptor (VR1) expression in vagal afferent neurons innervating the gastrointestinal tract. *Cell and tissue research* 2003;311:277-287.

23. Page AJ, Brierley SM, Martin CM, Price MP, Symonds E, Butler R, Wemmie JA, Blackshaw LA. Different contributions of ASIC channels 1a, 2, and 3 in gastrointestinal mechanosensory function. *Gut* 2005;54:1408-1415.
24. Caterina MJ, Schumacher MA, Tominaga M, Rosen TA, Levine JD, Julius D. The capsaicin receptor: a heat-activated ion channel in the pain pathway. *Nature* 1997;389:816-824.
25. Szallasi A, Blumberg PM. Vanilloid (Capsaicin) receptors and mechanisms. *Pharmacological reviews* 1999;51:159-212.
26. Geppetti P, Del Bianco E, Patacchini R, Santicioli P, Maggi CA, Tramontana M. Low pH-induced release of calcitonin gene-related peptide from capsaicin-sensitive sensory nerves: mechanism of action and biological response. *Neuroscience* 1991;41:295-301.
27. Matthews PJ, Aziz Q, Facer P, Davis JB, Thompson DG, Anand P. Increased capsaicin receptor TRPV1 nerve fibres in the inflamed human oesophagus. *European journal of gastroenterology & hepatology* 2004;16:897-902.
28. Trevisani M, Smart D, Gunthorpe MJ, Tognetto M, Barbieri M, Campi B, Amadesi S, Gray J, Jerman JC, Brough SJ, Owen D, Smith GD, Randall AD, Harrison S, Bianchi A, Davis JB, Geppetti P. Ethanol elicits and potentiates nociceptor responses via the vanilloid receptor-1. *Nature neuroscience* 2002;5:546-551.
29. Rodriguez-Stanley S, Collings KL, Robinson M, Owen W, Miner PB, Jr. The effects of capsaicin on reflux, gastric emptying and dyspepsia 3. *Alimentary Pharmacology & Therapeutics* 2000;14:129-134.
30. Caterina MJ. Vanilloid receptors take a TRP beyond the sensory afferent. *Pain* 2003;105:5-9.
31. Maggi CA. The dual, sensory and "efferent" function of the capsaicin-sensitive primary sensory neurons in the urinary bladder and uretra. In: Maggi CA, ed. *Nervous control of the urogenital system*. Chur: Harwood Academic Publishers, 1993:382-422.
32. Drewes AM, Schipper K, Dimcevski G, Petersen P, Gregersen H, Funch-Jensen P, Arendt-Nielsen L. Gut pain and hyperalgesia induced by capsaicin: A human experimental model. *Pain* 2003;104:333-341.

33. Pedersen J, Reddy H, Funch-Jensen P, Arendt-Nielsen L, Gregersen H, Drewes AM. Cold and heat pain assessment of the human oesophagus after experimental sensitisation with acid. *Pain* 2004;110:393-399.
34. Julius D. The molecular biology of thermosensation. In: Dostrovsky JO, Carr DB and Koltzenburg M, eds. *Proceedings of the 10th World Congress on Pain*, Vol. 24. Seattle: IASP Press, 2003:63-70.
35. Drewes AM, Reddy H, Staahl C, Funch-Jensen P, Arendt-Nielsen L, Gregersen H, Lundbye-Christensen S. Statistical modeling of the response characteristics of mechanosensitive stimuli in the human esophagus. *The journal of pain : official journal of the American Pain Society* 2005;6:455-462.
36. Cervero F, Laird JM. Visceral pain. *Lancet* 1999;353:2145-2148.
37. Arendt-Nielsen L. Induction and assessment of experimental pain from human skin, muscle, and viscera. In: Jensen TS, Turner JA and Wiesenfeld-Hallin Z, eds. *Proceedings of the 8th World Congress of Pain, Progress in Pain Research and Management*. Seattle: ISAP Press, 1997:393-425.
38. Ness TJ, Richter HE, Varner RE, Fillingim RB. A psychophysical study of discomfort produced by repeated filling of the urinary bladder 3. *Pain* 1998;76:61-69.
39. Ness TJ, Metcalf AM, Gebhart GF. A psychophysiological study in humans using phasic colonic distension as a noxious visceral stimulus. *Pain* 1990;43:377-386.
40. Drewes AM, Arendt-Nielsen L, Krarup HB, Hansen JB, Tage-Jensen U. Pain evoked by electrical stimulation of the prepyloric region of the stomach: cutaneous sensibility changes in the referred pain area. *Pain Research and Management* 1999;4:131-137.
41. Gebhart GF, Meller ST, Euchner-Wamser I, Sengupta JN. Modelling visceral pain. In: Vecchiet L, Albe-Fessard D, Lindblom U and Giamberardino MA, eds. *New trends in Referred Pain and Hyperalgesia*. Amsterdam: Elsevier, 1993:129-148.
42. Drewes AM. Experimentally evoked pain in the human gastrointestinal tract: Sensory manifestations to painful electrical stimuli. 1998;1-46.
43. Enggaard TP, Poulsen L, Arendt-Nielsen L, Hansen SH, Bjornsdottir I, Gram LF, Sindrup SH. The analgesic effect of codeine as compared to imipramine in different human experimental pain models 1. *Pain* 2001;92:277-282.

44. Arendt-Nielsen L, Petersen-Felix S, Fischer M, Bak P, Bjerring P, Zbinden AM. The effect of N-methyl-D-aspartate antagonist (ketamine) on single and repeated nociceptive stimuli: a placebo-controlled experimental human study. *Anesth.Analg.* 1995;81:63-68.
45. Hollerbach S, Hudoba P, Fitzpatrick D, Hunt R, Upton AR, Tougas G. Cortical evoked responses following esophageal balloon distension and electrical stimulation in healthy volunteers. *Dig.Dis.Sci.* 1998;43:2558-2566.
46. Curatolo M, Petersen-Felix S, Arendt-Nielsen L. Sensory assessment of regional analgesia in humans: a review of methods and applications . *Anesthesiology* 2000;93:1517-1530.
47. Accarino AM, Azpiroz F, Malagelada JR. Symptomatic responses to stimulation of sensory pathways in the jejunum. *Am.J.Physiol* 1992;263:G673-G677.
48. Distrutti E, Azpiroz F, Soldevilla A, Malagelada JR. Gastric wall tension determines perception of gastric distention. *Gastroenterology* 1999;116:1035-1042.
49. Gregersen H, Jorgensen CS, Dall FH. Biomechanical properties in the isolated perfused porcine duodenum. An experimental study using impedance planimetry. *J Gastrointes Mot* 1992;4:125-135.
50. DeVault KR. Acid infusion does not affect intraesophageal balloon distention-induced sensory and pain thresholds . *The American Journal of Gastroenterology* 1997;92:947-949.
51. Hu WH, Martin CJ, Talley NJ. Intraesophageal acid perfusion sensitizes the esophagus to mechanical distension: a Barostat study 2. *The American Journal of Gastroenterology* 2000;95:2189-2194.
52. Sarkar S, Aziz Q, Woolf CJ, Hobson AR, Thompson DG. Contribution of central sensitisation to the development of non-cardiac chest pain. *Lancet* 2000;356:1154-1159.
53. Drewes AM, Schipper KP, Dimcevski G, Petersen P, Andersen OK, Gregersen H, Arendt-Nielsen L. Multimodal assessment of pain in the esophagus: a new experimental model 2. *American Journal of Physiology. Gastrointestinal and Liver Physiology* 2002;283:G95-103.

54. Drewes AM, Schipper K, Dimcevski G, Petersen P, Andersen OK, Gregersen H, Arendt-Nielsen L. Multi-modal induction and assessment of allodynia and hyperalgesia in the human oesophagus. *Eur J Pain* 2003;7:539-549.
55. Mohr Drewes A, Pedersen J, Reddy H, Rasmussen K, Funch-Jensen P, Arendt-Nielsen L, Gregersen H. Central sensitization in patients with non-cardiac chest pain: a clinical experimental study. *Scandinavian journal of gastroenterology* 2006;41:640-649.
56. Zhao J, Frokjaer JB, Drewes AM, Ejksjaer N. Upper gastrointestinal sensory-motor dysfunction in diabetes mellitus. *World journal of gastroenterology : WJG* 2006;12:2846-2857.
57. Dimcevski G, Schipper KP, Tage-Jensen U, Funch-Jensen P, Krarup AL, Toft E, Thorsgaard N, Arendt-Nielsen L, Drewes AM. Hypoalgesia to experimental visceral and somatic stimulation in painful chronic pancreatitis. *European journal of gastroenterology & hepatology* 2006;18:755-764.
58. Staahl C, Christrup LL, Andersen SD, Arendt-Nielsen L, Drewes AM. A comparative study of oxycodone and morphine in a multi-modal, tissue-differentiated experimental pain model. *Pain* 2006;123:28-36.
59. Lundell LR, Dent J, Bennett JR, Blum AL, Armstrong D, Galmiche JP, Johnson F, Hongo M, Richter JE, Spechler SJ, Tytgat GN, Wallin L. Endoscopic assessment of oesophagitis: clinical and functional correlates and further validation of the Los Angeles classification. *Gut* 1999;45:172-180.
60. Gregersen H, Andersen MB. Impedance measuring system for cross-sectional area in the gastrointestinal tract. *Med Biol Eng Comput* 1991;29:108-110.
61. Gregersen H, Stodkilde-Jorgensen H, Djurhuus JC. The four-electrode impedance technique: A method for investigation of compliance in luminal organs. *Clin Phys Physiol Meas* 1988;9 (Suppl A):61-64.
62. Gregersen H, Kassab G. Biomechanics of the gastrointestinal tract. *Neurogastroenterol.Motil.* 1996;8:277-297.
63. Rao SS, Gregersen H, Hayek B, Summers RW, Christensen J. Unexplained chest pain: the hypersensitive, hyperreactive, and poorly compliant esophagus . *Ann.Intern.Med.* 1996;124:950-958.

64. Hobson AR, Aziz Q, Furlong PL, Barlow JD, Bancewicz J, Thompson DG. Identification of the optimal parameters for recording cortical evoked potentials to human oesophageal electrical stimulation. *Neurogastroenterol.Motil.* 1998;10:421-430.
65. Gao C. Biomechanical properties and sensory nerve function in the human small intestine. 2001;. PhD Thesis, Aalborg Univeristy.
66. Pedersen J, Gao C, Egekvist H, Bjerring P, Arendt-Nielsen L, Gregersen H, Drewes AM. Pain and biomechanical responses to distension of the duodenum in patients with systemic sclerosis. *Gastroenterol* 2003.
67. Mehta AJ, De Caestecker JS, Camm AJ, Northfield TC. Sensitization to painful distention and abnormal sensory perception in the esophagus. *Gastroenterology* 1995;108:311-319.
68. Gregersen H. *Biomechanics of the Gastrointestinal Tract.* London: Springer Verlag, 2002.
69. Shirazi S, Schulze-Delrieu K, Custer-Hagen T, Brown CK, Ren J. Motility changes in opossum esophagus from experimental esophagitis. *Dig Dis Sci* 1989;34:1668-1676.
70. White RJ, Zhang Y, Morris GP, Paterson WG. Esophagitis-related esophageal shortening in opossum is associated with longitudinal muscle hyperresponsiveness. *American journal of physiology.Gastrointestinal and liver physiology* 2001;280:G463-9.
71. Sifrim D, Janssens J, Vantrappen G. Transient lower esophageal sphincter relaxations and esophageal body muscular contractile response in normal humans. *Gastroenterology* 1996;110:659-668.
72. Drewes AM, Pedersen J, Liu W, Arendt-Nielsen L, Gregersen H. Controlled mechanical distension of the human oesophagus: Sensory and biomechanical findings. *Scand.J.Gastroenterol.* 2003;38:27-35.
73. Gao C, Arendt-Nielsen L, Liu.W, Petersen P, Drewes AM, Gregersen G. Sensory and biomechanical responses to ramp-controlled distension of the human duodenum. *Am J Physiol Gastrointest Liver Physiol* 2002.
74. Nguyen P, Lee SD, Castell DO. Evidence of gender differences in esophageal pain threshold. *The American Journal of Gastroenterology* 1995;90:901-905.

75. Soffer EE, Kongara K, Achkar JP, Gannon J. Colonic motor function in humans is not affected by gender 1. *Digestive diseases and sciences* 2000;45:1281-1284.
76. Sloots CE, Felt-Bersma RJ, Cuesta MA, Meuwissen SG. Rectal visceral sensitivity in healthy volunteers: influences of gender, age and methods . *Neurogastroenterol.Motil.* 2000;12:361-368.
77. Kern MK, Jaradeh S, Arndorfer RC, Jesmanowicz A, Hyde J, Shaker R. Gender differences in cortical representation of rectal distension in healthy humans. *American Journal of Physiology. Gastrointestinal and Liver Physiology* 2001;281:G1512-G1523.
78. Bajaj P, Arendt-Nielsen L, Bajaj P, Madsen H. Sensory changes during the ovulatory phase of the menstrual cycle in healthy women. *European journal of pain (London, England)* 2001;5:135-144.
79. Giamberardino MA. Sex-related and hormonal modulation of visceral pain. In: Fillingim R, ed. *Sex, gender and pain*. Seattle: IASP Press, 2000:135-164.
80. Fass R. Epidemiology and pathophysiology of symptomatic gastroesophageal reflux disease. *American Journal of Gastroenterology* 2003;98:S2-S7.
81. Barlow WJ, Orlando RC. The pathogenesis of heartburn in nonerosive reflux disease: a unifying hypothesis. *Gastroenterology* 2005;128:771-778.
82. Lebars D, Dickenson AH, Besson JM. Diffuse Noxious Inhibitory Controls (Dnic) . Effects on Dorsal Horn Convergent Neurons in the Rat. *Pain* 1979;6:283-304.
83. Suzuki R, Morcuende S, Webber M, Hunt SP, Dickenson AH. What the brain tells the spinal cord: Lamina I/III NK1-expressing neurons control spinal activity via descending pathways. *Proceedings of the 10th World Congress on Pain, Progress in Pain Research and Management*. Seattle 2003;337-343.
84. Roza C, Laird JM, Cervero F. Spinal mechanisms underlying persistent pain and referred hyperalgesia in rats with an experimental ureteric stone 1. *Journal of neurophysiology* 1998;79:1603-1612.
85. Bernstein CN, Niazi N, Robert M, Mertz H, Kodner A, Munakata J, Naliboff B, Mayer EA. Rectal afferent function in patients with inflammatory and functional intestinal disorders. *Pain* 1996;66:151-161.

86. Munakata J, Naliboff B, Harraf F, Kodner A, Lembo T, Chang L, Silverman DH, Mayer EA. Repetitive sigmoid stimulation induces rectal hyperalgesia in patients with irritable bowel syndrome [published erratum appears in *Gastroenterology* 1997 Sep;113(3):1054]. *Gastroenterology* 1997;112:55-63.
87. Mertz H, Fullerton S, Naliboff B, Mayer EA. Symptoms and visceral perception in severe functional and organic dyspepsia. *Gut* 1998;42:814-822.
88. Schmulson M, Chang L, Naliboff B, Lee OY, Mayer EA. Correlation of symptom criteria with perception thresholds during rectosigmoid distension in irritable bowel syndrome patients. *Am.J.Gastroenterol.* 2000;95:152-156.
89. Rodriguez-Stanley S, Robinson M, Earnest DL, Greenwood-Van Meerveld B, Miner PB, Jr. Esophageal hypersensitivity may be a major cause of heartburn. *The American Journal of Gastroenterology* 1999;94:628-631.
90. Trimble KC, Pryde A, Heading RC. Lowered oesophageal sensory thresholds in patients with symptomatic but not excess gastro-oesophageal reflux: evidence for a spectrum of visceral sensitivity in GORD. *Gut* 1995;37:7-12.
91. Arendt-Nielsen L, Laursen RJ, Drewes AM. Referred pain as an indicator for neural plasticity 7. *Progress in brain research* 2000;129:343-356.
92. Penagini R, Hebbard G, Horowitz M, Dent J, Bermingham H, Jones K, Holloway RH. Motor function of the proximal stomach and visceral perception in gastro-oesophageal reflux disease. *Gut* 1998;42:251-257.
93. Giamberardino MA. Recent and forgotten aspects of visceral pain. *Eur J Pain* 1999;3:77-92.
94. Sarkar S, Hobson AR, Furlong PL, Woolf CJ, Thompson DG, Aziz Q. Central neural mechanisms mediating human visceral hypersensitivity 1. *American Journal of Physiology. Gastrointestinal and Liver Physiology* 2001;281:G1196-G1202.
95. Sami SAK, Rössel P, Dimcevski G, Nielsen KD, Funch-Jensen P, Valeriani M, Arendt-Nielsen L, Drewes AM. Cortical changes to experimental sensitization of the human esophagus. *Neuroscience* 2006.
96. Wong WM, Lai KC, Lam KF, Hui WM, Hu WH, Lam CL, Xia HH, Huang JQ, Chan CK, Lam SK, Wong BC. Prevalence, clinical spectrum and health care utilization of gastro-oesophageal reflux disease in a Chinese population: a population-based study. *Alimentary Pharmacology & Therapeutics* 2003;18:595-604.

97. Kahrilas PJ. Gastroesophageal reflux disease. JAMA : the journal of the American Medical Association 1996;276:983-988.

98. Mohr Drewes A, Pedersen J, Reddy H, Rasmussen K, Funch-Jensen P, Arendt-Nielsen L, Gregersen H. Central sensitization in patients with non-cardiac chest pain: a clinical experimental study. Scandinavian journal of gastroenterology 2006;41:640-649.